



The Timken Company

4500 Mt Pleasant St. NW

N. Canton, OH 44720

Phone: (234) 262-3000

E-Mail: CustomerCAD@timken.com • **Web site:** www.timken.com

Part Number QAMC10A115S, Single Concentric Cartridge Block

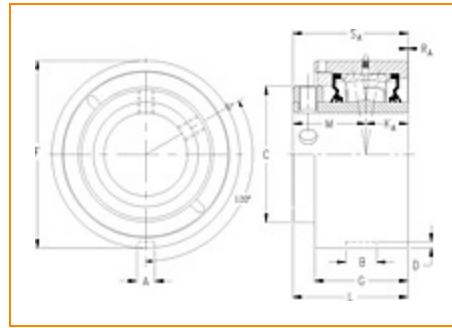

[Specifications](#) | [Dimensions](#) | [Radial and Thrust Factors](#) | [Engineering Seal Speed](#) | [Engineering Bearing Attributes](#) | [Engineering Internal Radial Clearance](#)

Specifications

Engineering Group Mounted Bearing

Bearing Number 22210

Shaft Size 1 15/16 in

Shaft Size Type Imperial

Full Timken Part Number

- QAMC10A115SB
- QAMC10A115SC
- QAMC10A115SEB
- QAMC10A115SEC
- QAMC10A115SEM
- QAMC10A115SEN
- QAMC10A115SEO
- QAMC10A115SET
- QAMC10A115SM
- QAMC10A115SMSLA
- QAMC10A115SN
- QAMC10A115SO



QAMC10A115ST

Locking Style	Single Concentric
Housing Construction	Cartridge
UPC Code	0883450042703 0883450042710 0883450042734 0883450042741 0883450042758 0883450042765 0883450042772 0883450042789 0883450194495 0883450194655 0883450271660 0883450271820 0883450434331

Dimensions

Dimension A	0.53 in 13.5 mm
Dimension B	0.91 in 23.1 mm
Dimension C	2.88 in 73.2 mm
Dimension D	0.19 in 4.8 mm
Dimension F	4.1250 in 104.8 mm
Dimension G	2.45 in 62.2 mm
Dimension KA	1 in 25.4 mm

Dimension L Exp	3.2 in 81.3 mm
Dimension L Fix	3.12 in 79.2 mm
Dimension M	1.87 in 47.5 mm
Dimension RA	0.24 in 6.1 mm
Dimension SA	2.87 in 72.9 mm

Radial and Thrust Factors

C0 - Static Load	26600 lbf 118000 N
C - Dynamic Load (Basic)	26300 lbf 117000 N
e - Geometry Factor	0.24
Y1 - Geometry Factor	2.84
Y2 - Geometry Factor	4.23

Engineering Seal Speed

Oil Lubrication - M/N Seal	2400 rpm
Oil Lubrication - T Seal	4200 rpm
Oil Lubrication - B/C/O Seal	1800 rpm
Grease Lubrication - M/N Seal	2400 rpm
Grease Lubrication - T Seal	3550 rpm
Grease Lubrication - B/C/O Seal	1800 rpm

Engineering Bearing Attributes

Float	0.050 in 1.270 mm
Shaft Tolerance	0.0015 in 0.038 mm

Engineering Internal Radial Clearance

Eng Internal Radial Clearance - Min	0.0014
Eng Internal Radial Clearance - Max	0.0022
Pre Install Clearance Min	0.0016 in 0.040 mm
Pre Install Clearance Max	0.0026 in 0.065 mm

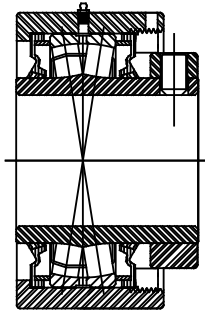
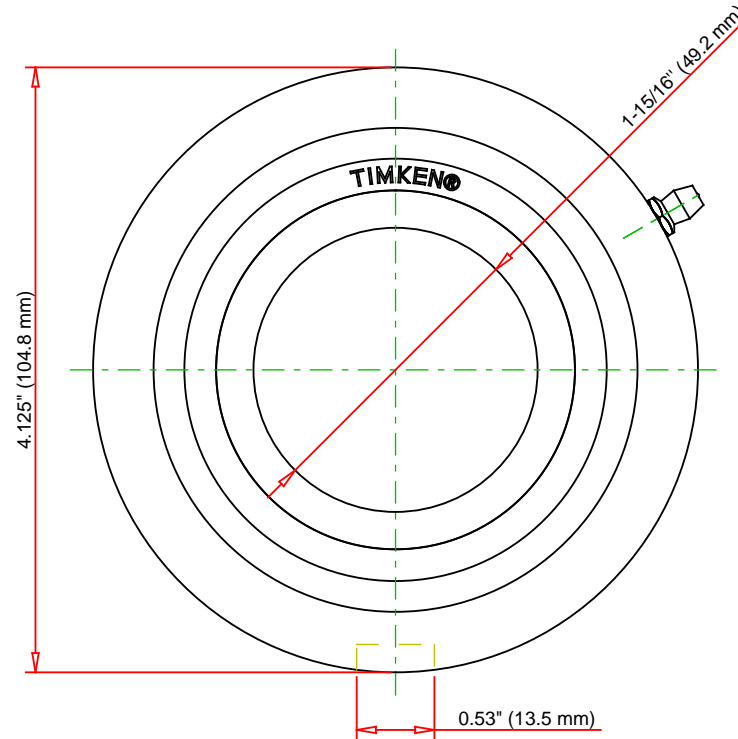
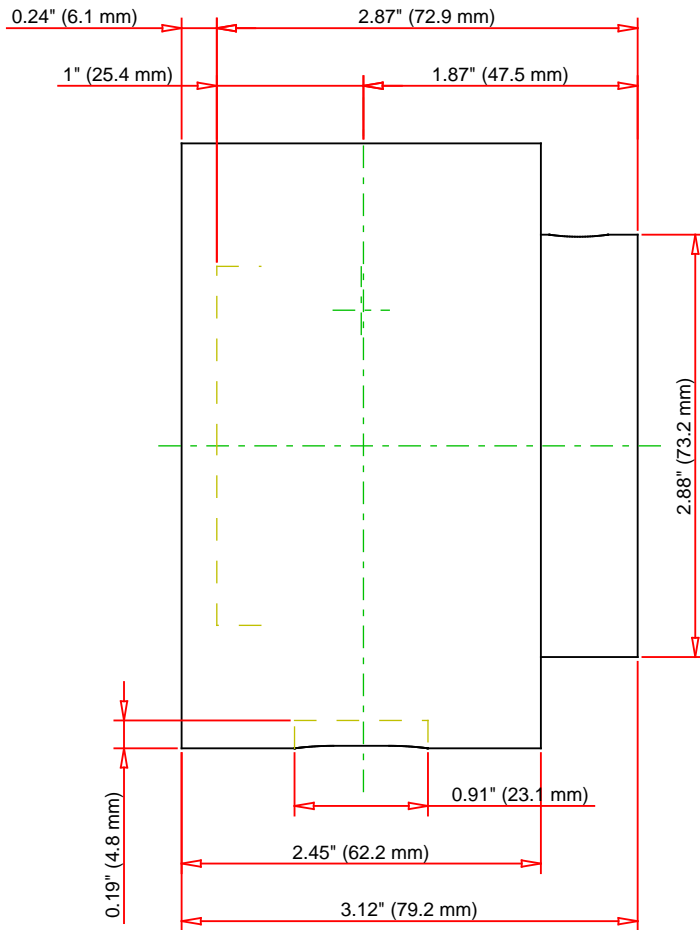

Note: Section View not to Scale

C - Dynamic Load	26300	lbf	117000	N
C0 - Static Load	26600	lbf	118000	N
Weight	8	lb	3.6	kg
Max. Speed T-Seals & Grease	3550	rpm		
Rad. Clearance - Max.	0.0022			

TIMKEN

THE TIMKEN COMPANY
NORTH CANTON, OHIO USA

QAMC10A115S
Single Concentric Cartridge Block

Every reasonable effort has been made to ensure the accuracy of the information contained in this writing, but no liability is accepted for errors, omissions or for any other reason.

FOR DISCUSSION ONLY