



The Timken Company

4500 Mt Pleasant St. NW

N. Canton, OH 44720

Phone: (234) 262-3000

E-Mail: CustomerCAD@timken.com • **Web site:** www.timken.com

Part Number QVC11V050S, Single V-Lock Piloted Flange Cartridge

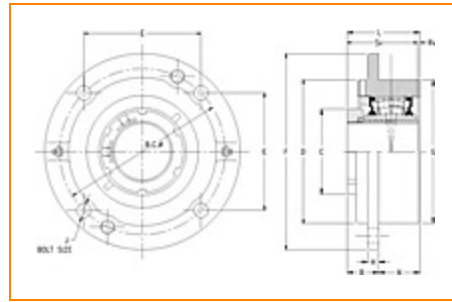
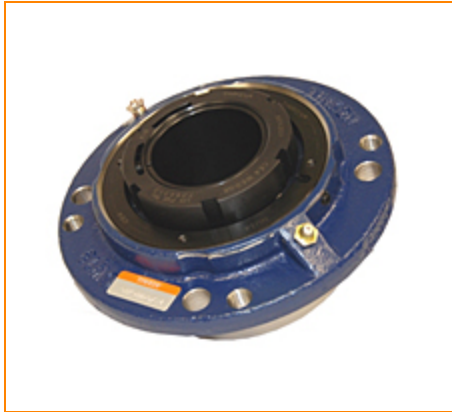

[Specifications](#) | [Dimensions](#) | [Radial and Thrust Factors](#) | [Engineering Seal Speed](#) | [Engineering Bearing Attributes](#) | [Engineering Internal Radial Clearance](#)

Specifications

Engineering Group Mounted Bearing

Bearing Number 22211

Shaft Size 50 mm

Shaft Size Type Metric

Full Timken Part Number

- QVC11V050SB
- QVC11V050SC
- QVC11V050SEB
- QVC11V050SEC
- QVC11V050SEM
- QVC11V050SEN
- QVC11V050SEO
- QVC11V050SET
- QVC11V050SM
- QVC11V050SN
- QVC11V050SO
- QVC11V050ST



Locking Style	Single V-Lock
Housing Construction	Piloted Flange Cartridge

UPC Code	0883450089944
	0883450090414
	0883450101325
	0883450101752
	0883450108881
	0883450109024
	0883450116718
	0883450117166
	0883450130967
	0883450131360
0883450139458	
0883450139540	

Dimensions

Dimension BC	5.38 in 136.7 mm
---------------------	---------------------

Dimension C	2.99 in 75.9 mm
--------------------	--------------------

Dimension D	4.47 in 113.5 mm
--------------------	---------------------

Dimension E	3.8 in 96.5 mm
--------------------	-------------------

Dimension B Exp	2.2 in 55.9 mm
------------------------	-------------------

Dimension B Fix	2.12 in 53.8 mm
------------------------	--------------------

Dimension F	6.38 in 162.1 mm
--------------------	---------------------

Dimension H	0.63 in 16 mm
--------------------	------------------

Dimension J (Bolt Size)	0.438 in 10 mm
Dimension L	3.18 in 80.8 mm
Dimension RV	0.03 in 0.8 mm
Dimension SV	3.14 in 79.8 mm
Dimension G	4.5 in 114.3 mm
Dimension N	1.06 in 26.9 mm

Radial and Thrust Factors

C0 - Static Load	31900 lbf 142000 N
C - Dynamic Load (Basic)	31400 lbf 140000 N
e - Geometry Factor	0.23
Y1 - Geometry Factor	2.95
Y2 - Geometry Factor	4.40

Engineering Seal Speed

Oil Lubrication - M/N Seal	2200 rpm
Oil Lubrication - T Seal	3800 rpm
Oil Lubrication - B/C/O Seal	1800 rpm
Grease Lubrication - M/N Seal	2200 rpm

Grease Lubrication - T Seal	3200 rpm
------------------------------------	----------

Grease Lubrication - B/C/O Seal	1600 rpm
--	----------

Engineering Bearing Attributes

Float	0.050 in 1.270 mm
--------------	----------------------

Shaft Tolerance	0.0015 in 0.038 mm
------------------------	-----------------------

Engineering Internal Radial Clearance

Eng Internal Radial Clearance - Min	0.0030
--	--------

Eng Internal Radial Clearance - Max	0.0037
--	--------

Pre Install Clearance Min	0.0030 in 0.075 mm
----------------------------------	-----------------------

Pre Install Clearance Max	0.0037 in 0.094 mm
----------------------------------	-----------------------

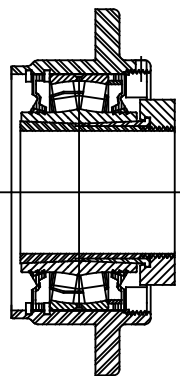
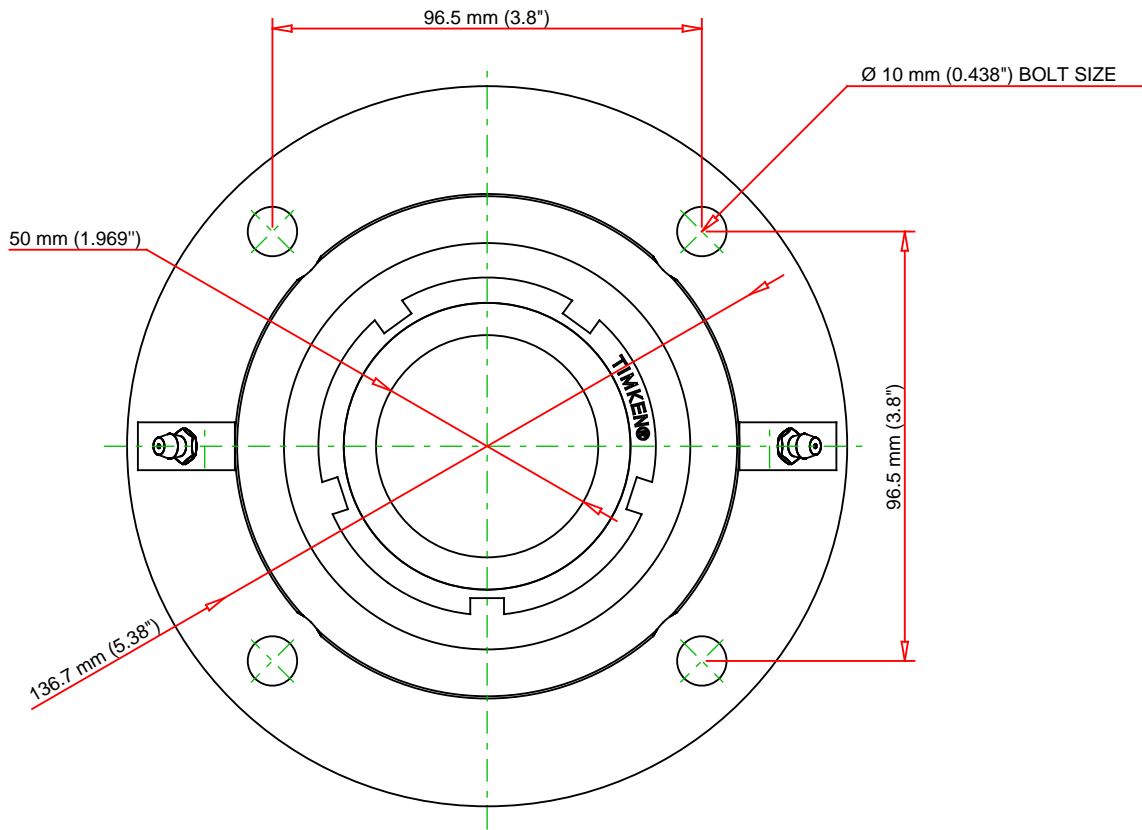
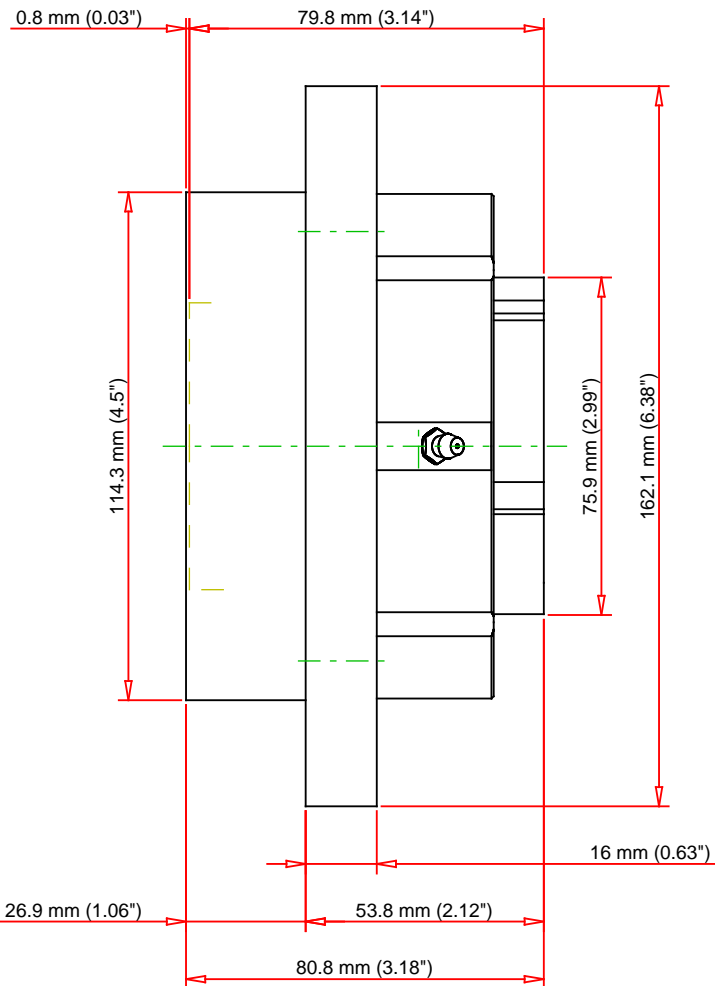

Note: Section View not to Scale

C - Dynamic Load	31400	lbf	140000	N
C0 - Static Load	31900	lbf	142000	N
Weight	10	lb	4.5	kg
Max. Speed T-Seals & Grease	3200	rpm		
Rad. Clearance - Max.	0.0037			

TIMKEN

THE TIMKEN COMPANY
NORTH CANTON, OHIO USA

QVC11V050S
Single V-Lock Piloted Flange Cartridge

Every reasonable effort has been made to ensure the accuracy of the information contained in this writing, but no liability is accepted for errors, omissions or for any other reason.

FOR DISCUSSION ONLY