



The Timken Company

4500 Mt Pleasant St. NW

N. Canton, OH 44720

Phone: (234) 262-3000

E-Mail: CustomerCAD@timken.com • **Web site:** www.timken.com

Part Number QVVPH26V407S, Double V-Lock Four-Bolt Pillow Block

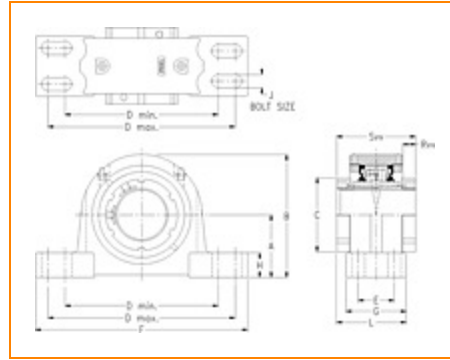
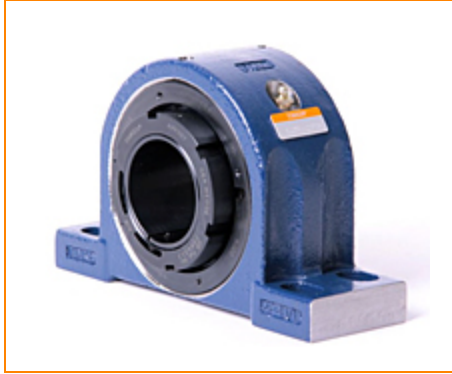

[Specifications](#) | [Dimensions](#) | [Radial and Thrust Factors](#) | [Engineering Seal Speed](#) | [Engineering Bearing Attributes](#) | [Engineering Internal Radial Clearance](#)

Specifications

Engineering Group Mounted Bearing

Bearing Number 22226

Shaft Size 4 7/16 in

Shaft Size Type Imperial

Full Timken Part Number

- QVVPH26V407SB
- QVVPH26V407SC
- QVVPH26V407SEB
- QVVPH26V407SEC
- QVVPH26V407SEM
- QVVPH26V407SEN
- QVVPH26V407SEO
- QVVPH26V407SET
- QVVPH26V407SM
- QVVPH26V407SN
- QVVPH26V407SO
- QVVPH26V407ST



Locking Style	Double V-Lock
Housing Construction	Four-Bolt Pillow Block
UPC Code	0883450076425 0883450076432 0883450209229 0883450209373 0883450221658 0883450221801 0883450234085 0883450234238 0883450242820 0883450242974 0883450247788 0883450247931

Dimensions

Dimension A	6 in 152.4 mm
Dimension B	11.18 in 284 mm
Dimension C	6.88 in 174.8 mm
Dimension D Min	14.25 in 362 mm
Dimension D Max	15.75 in 400.1 mm
Dimension E	3.25 in 82.6 mm
Dimension F	17-1/2 in 444.5 mm
Dimension G	5.04 in 128 mm

Dimension H	2.04 in 51.8 mm
Dimension J (Bolt Size)	0.875 in 24 mm
Dimension L	6.03 in 153.2 mm
Dimension RVV	1.44 in 36.6 mm
Dimension SVV	7.02 in 178.3 mm

Radial and Thrust Factors

C0 - Static Load	212000 lbf 945000 N
C - Dynamic Load (Basic)	170000 lbf 757000 N
e - Geometry Factor	0.26
Y1 - Geometry Factor	2.62
Y2 - Geometry Factor	3.9

Engineering Seal Speed

Oil Lubrication - M/N Seal	700 rpm
Oil Lubrication - T Seal	1500 rpm
Oil Lubrication - B/C/O Seal	400 rpm
Grease Lubrication - M/N Seal	700 rpm
Grease Lubrication - T Seal	1000 rpm
Grease Lubrication - B/C/O Seal	400 rpm

Engineering Bearing Attributes

Float	0.083 in 2.108 mm
--------------	----------------------

Shaft Tolerance	0.0050 in 0.127 mm
------------------------	-----------------------

Engineering Internal Radial Clearance

Eng Internal Radial Clearance - Min	0.0053
--	--------

Eng Internal Radial Clearance - Max	0.0067
--	--------

Pre Install Clearance Min	0.0053 in 0.135 mm
----------------------------------	-----------------------

Pre Install Clearance Max	0.0067 in 0.170 mm
----------------------------------	-----------------------

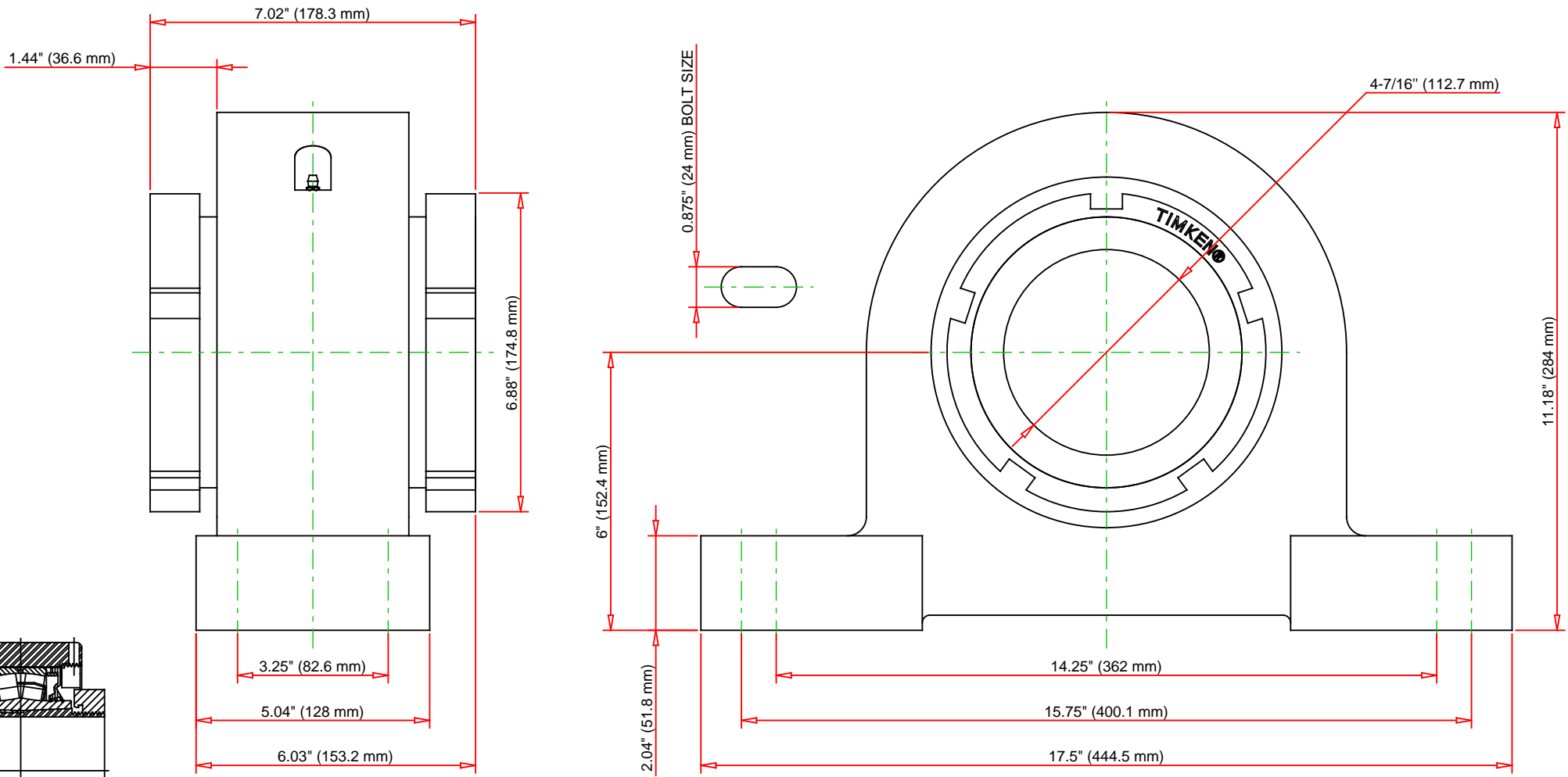

Note: Section View not to Scale

C - Dynamic Load	170000	lbf	757000	N
C0 - Static Load	212000	lbf	945000	N
Weight	136	lb	61.7	kg
Max. Speed T-Seals & Grease	1000	rpm		
Rad. Clearance - Max.	0.0067			

TIMKEN

THE TIMKEN COMPANY
NORTH CANTON, OHIO USA

QVVPH26V407S
Double V-Lock Four-Bolt Pillow Block

Every reasonable effort has been made to ensure the accuracy of the information contained in this writing, but no liability is accepted for errors, omissions or for any other reason.

FOR DISCUSSION ONLY