



The Timken Company

4500 Mt Pleasant St. NW

N. Canton, OH 44720

Phone: (234) 262-3000

E-Mail: CustomerCAD@timken.com • **Web site:** www.timken.com

Part Number DVP15K207S, Tapered Adapter Two-Bolt Pillow Block

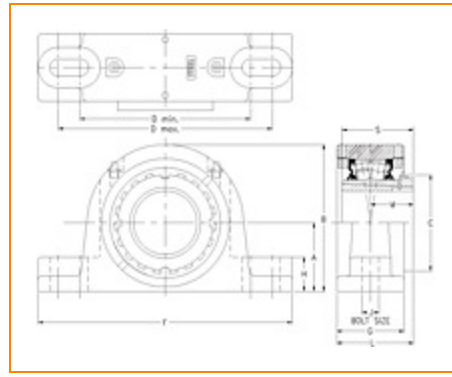
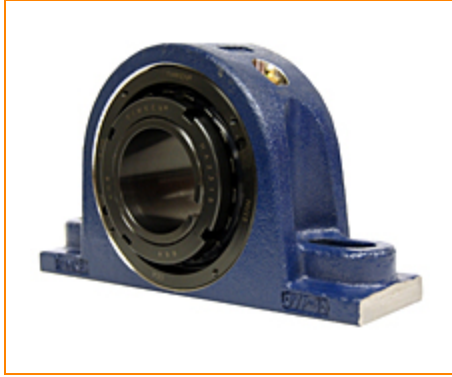

[Specifications](#) | [Dimensions](#) | [Radial and Thrust Factors](#) | [Engineering Seal Speed](#) | [Engineering Bearing Attributes](#) | [Engineering Internal Radial Clearance](#)

Specifications

Engineering Group Mounted Bearing

Bearing Number 22215

Shaft Size 2 7/16 in

Shaft Size Type Imperial

Full Timken Part Number

- DVP15K207SB
- DVP15K207SC
- DVP15K207SEB
- DVP15K207SEC
- DVP15K207SEM
- DVP15K207SEN
- DVP15K207SEO
- DVP15K207SET
- DVP15K207SM
- DVP15K207SN
- DVP15K207SO
- DVP15K207ST



Locking Style	Tapered Adapter
Housing Construction	Two-Bolt Pillow Block
UPC Code	0883450008228 0883450008235 0883450008259 0883450008266 0883450008273 0883450008280 0883450008297 0883450008303 0883450195690 0883450195898 0883450273206 0883450273404

Dimensions

Dimension A	2.75 in 69.9 mm
Dimension B	5.9 in 149.9 mm
Dimension C	3.86 in 98 mm
Dimension D Min	6.88 in 174.8 mm
Dimension D Max	8.63 in 219.2 mm
Dimension F	10 1/4 in 260.4 mm
Dimension G	2.7 in 68.6 mm
Dimension H	1.38 in 35.1 mm

Dimension J (Bolt Size)	0.625 in 16 mm
--------------------------------	-------------------

Dimension L	3.08 in 78.2 mm
--------------------	--------------------

Dimension M	1.73 in 43.9 mm
--------------------	--------------------

Dimension S	2.89 in 73.4 mm
--------------------	--------------------

Radial and Thrust Factors

C0 - Static Load	54100 lbf 240000 N
-------------------------	-----------------------

C - Dynamic Load (Basic)	49900 lbf 222000 N
---------------------------------	-----------------------

e - Geometry Factor	0.22
----------------------------	------

Y1 - Geometry Factor	3.14
-----------------------------	------

Y2 - Geometry Factor	4.67
-----------------------------	------

Engineering Seal Speed

Oil Lubrication - M/N Seal	1600 rpm
-----------------------------------	----------

Oil Lubrication - T Seal	2900 rpm
---------------------------------	----------

Oil Lubrication - B/C/O Seal	1300 rpm
-------------------------------------	----------

Grease Lubrication - M/N Seal	1600 rpm
--------------------------------------	----------

Grease Lubrication - T Seal	2400 rpm
------------------------------------	----------

Grease Lubrication - B/C/O Seal	1300 rpm
--	----------

Engineering Bearing Attributes

Float	0.083 in 2.108 mm
--------------	----------------------

Shaft Tolerance	0.0035 in 0.089 mm
------------------------	-----------------------

Engineering Internal Radial Clearance

Eng Internal Radial Clearance - Min	0.0037
--	--------

Eng Internal Radial Clearance - Max	0.0047
--	--------

Pre Install Clearance Min	0.0037 in 0.095 mm
----------------------------------	-----------------------

Pre Install Clearance Max	0.0047 in 0.120 mm
----------------------------------	-----------------------

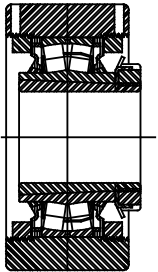
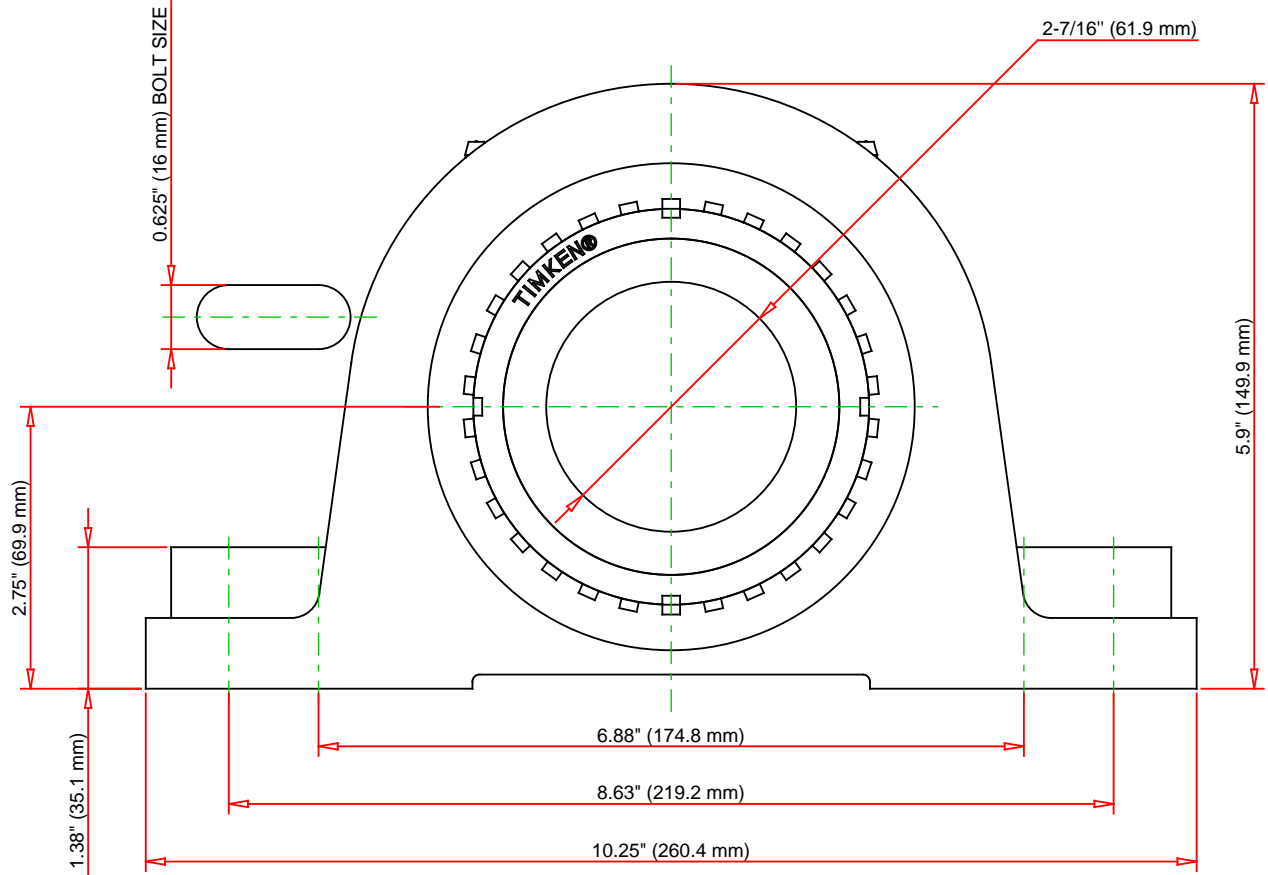
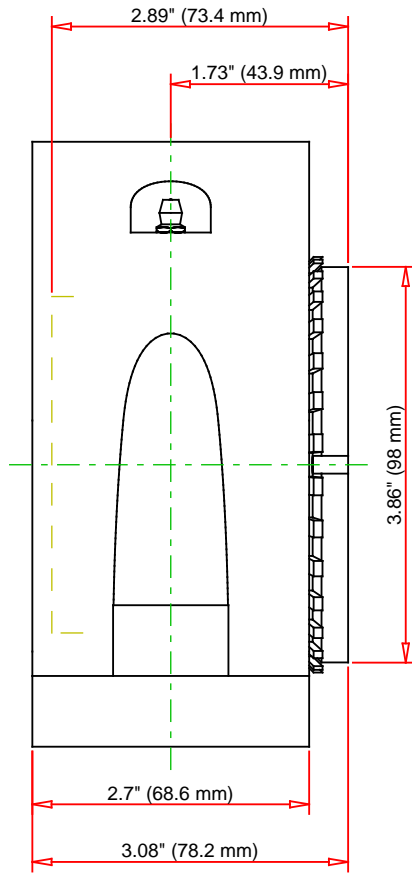

Note: Section View not to Scale

C - Dynamic Load	49900	lbf	222000	N
C0 - Static Load	54100	lbf	240000	N
Weight	25	lb	11.3	kg
Max. Speed T-Seals & Grease	2400	rpm		
Rad. Clearance - Max.	0.0047			

TIMKEN

THE TIMKEN COMPANY
NORTH CANTON, OHIO USA

DVP15K207S

Tapered Adapter Two-Bolt Pillow
Block

Every reasonable effort has been made to ensure the accuracy of the information contained in this writing, but no liability is accepted for errors, omissions or for any other reason.

FOR DISCUSSION ONLY