



The Timken Company

4500 Mt Pleasant St. NW

N. Canton, OH 44720

Phone: (234) 262-3000

E-Mail: CustomerCAD@timken.com • **Web site:** www.timken.com

Part Number QMPX18J307S, Eccentric Four-Bolt Pillow Block

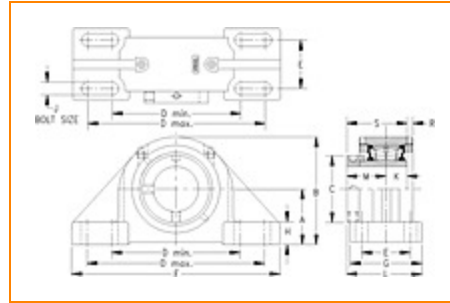
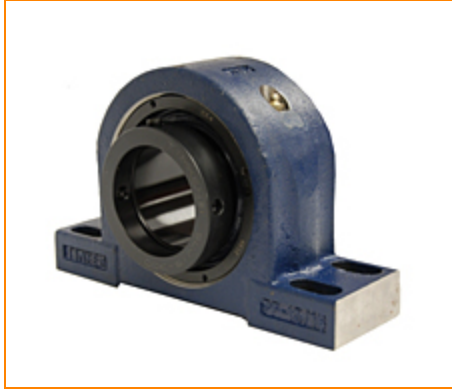

[Specifications](#) | [Dimensions](#) | [Radial and Thrust Factors](#) | [Engineering Seal Speed](#) | [Engineering Bearing Attributes](#) | [Engineering Internal Radial Clearance](#)

Specifications

Engineering Group Mounted Bearing

Bearing Number 22218

Shaft Size 3 7/16 in

Shaft Size Type Imperial

Full Timken Part Number

- QMPX18J307SB
- QMPX18J307SC
- QMPX18J307SEB
- QMPX18J307SEC
- QMPX18J307SEM
- QMPX18J307SEN
- QMPX18J307SEO
- QMPX18J307SET
- QMPX18J307SM
- QMPX18J307SN
- QMPX18J307SO
- QMPX18J307ST



Locking Style	Eccentric
Housing Construction	Four-Bolt Pillow Block
UPC Code	0883450094023 0883450094030 0883450094054 0883450094061 0883450094078 0883450094085 0883450094092 0883450094108 0883450159463 0883450160193 0883450252751 0883450253178

Dimensions

Dimension A	4 in 101.6 mm
Dimension B	7.92 in 201.2 mm
Dimension C	4.76 in 120.9 mm
Dimension D Min	10.81 in 274.6 mm
Dimension D Max	12.19 in 309.6 mm
Dimension E	3 in 76.2 mm
Dimension F	15 in 381 mm
Dimension G	4.75 in 120.7 mm

Dimension H	1 1/2 in 38.1 mm
--------------------	---------------------

Dimension J (Bolt Size)	0.75 in 20 mm
--------------------------------	------------------

Dimension K	1.44 in 36.6 mm
--------------------	--------------------

Dimension L	4.96 in 126 mm
--------------------	-------------------

Dimension M	2.59 in 65.8 mm
--------------------	--------------------

Dimension R	0.32 in 8.1 mm
--------------------	-------------------

Dimension S	4.03 in 102.4 mm
--------------------	---------------------

Radial and Thrust Factors

C0 - Static Load	87200 lbf 388000 N
-------------------------	-----------------------

C - Dynamic Load (Basic)	79700 lbf 355000 N
---------------------------------	-----------------------

e - Geometry Factor	0.23
----------------------------	------

Y1 - Geometry Factor	2.90
-----------------------------	------

Y2 - Geometry Factor	4.31
-----------------------------	------

Engineering Seal Speed

Oil Lubrication - M/N Seal	1400 rpm
-----------------------------------	----------

Oil Lubrication - T Seal	2400 rpm
---------------------------------	----------

Oil Lubrication - B/C/O Seal	1000 rpm
-------------------------------------	----------

Grease Lubrication - M/N Seal	1400 rpm
--------------------------------------	----------

Grease Lubrication - T Seal	2000 rpm
------------------------------------	----------

Grease Lubrication - B/C/O Seal	1000 rpm
--	----------

Engineering Bearing Attributes

Float	0.083 in
	2.108 mm

Shaft Tolerance	0.0030 in
	0.076 mm

Engineering Internal Radial Clearance

Eng Internal Radial Clearance - Min	0.0024
--	--------

Eng Internal Radial Clearance - Max	0.0039
--	--------

Pre Install Clearance Min	0.0024 in
	0.060 mm

Pre Install Clearance Max	0.0039 in
	0.100 mm

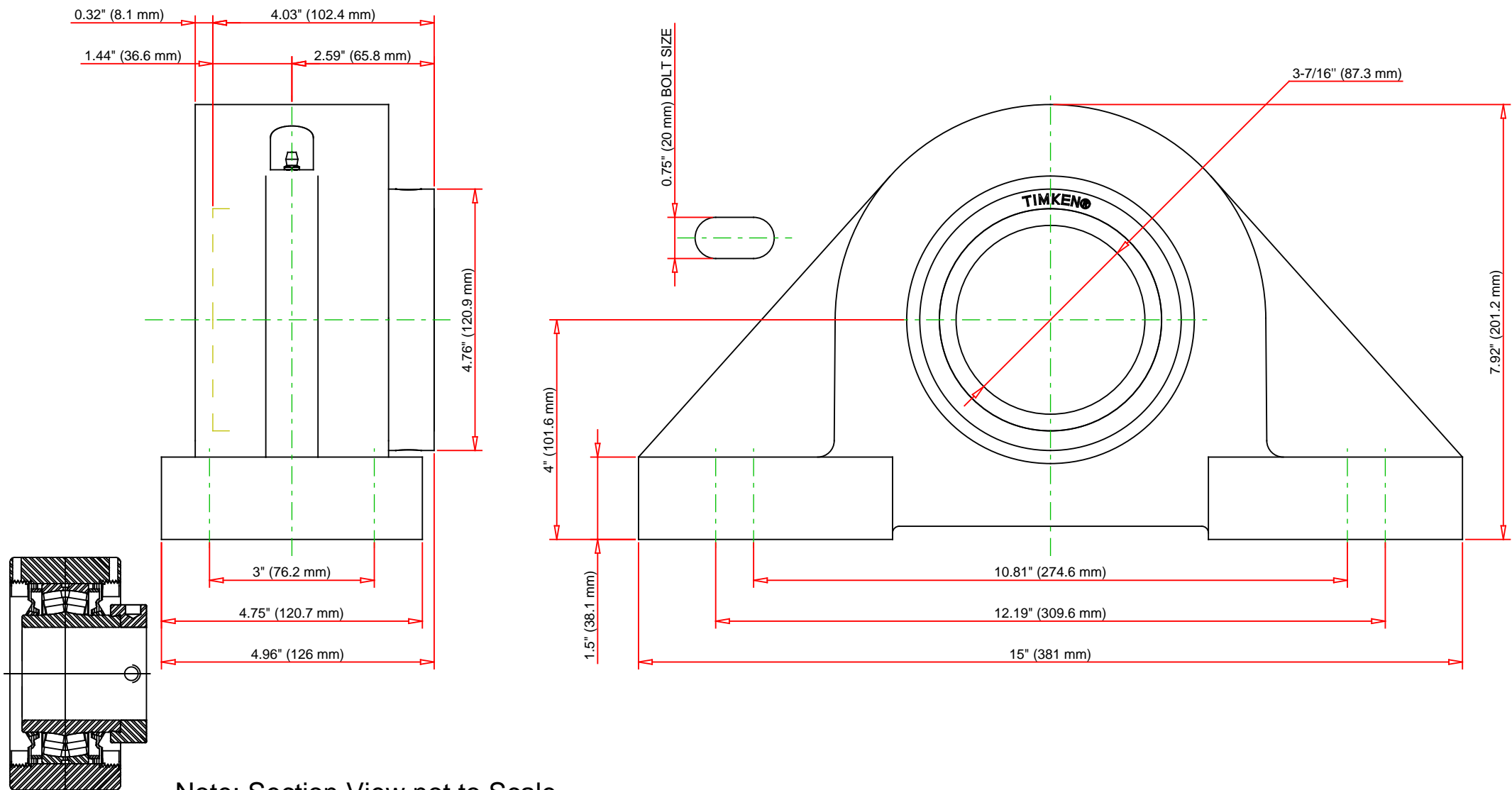

C - Dynamic Load	79700	lbf	355000	N
C0 - Static Load	87200	lbf	388000	N
Weight	49	lb	22.2	kg
Max. Speed T-Seals & Grease	2000	rpm		
Rad. Clearance - Max.	0.0039			

TIMKEN

THE TIMKEN COMPANY
 NORTH CANTON, OHIO USA

QMPX18J307S
 Eccentric Four-Bolt Pillow Block

Every reasonable effort has been made to ensure the accuracy of the information contained in this writing, but no liability is accepted for errors, omissions or for any other reason.

FOR DISCUSSION ONLY