



The Timken Company

4500 Mt Pleasant St. NW

N. Canton, OH 44720

Phone: (234) 262-3000

E-Mail: CustomerCAD@timken.com • **Web site:** www.timken.com

Part Number QMP11J203S, Eccentric Two-Bolt Pillow Block

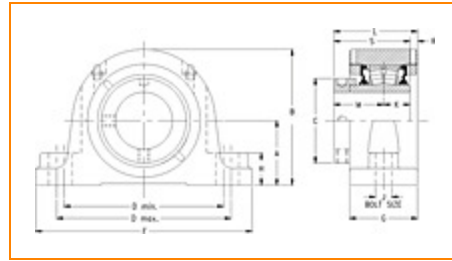

[Specifications](#) | [Dimensions](#) | [Radial and Thrust Factors](#) | [Engineering Seal Speed](#) | [Engineering Bearing Attributes](#) | [Engineering Internal Radial Clearance](#)

Specifications

Engineering Group Mounted Bearing

Bearing Number 22211

Shaft Size 2 3/16 in

Shaft Size Type Imperial

Full Timken Part Number

- QMP11J203SB
- QMP11J203SC
- QMP11J203SEB
- QMP11J203SEC
- QMP11J203SEM
- QMP11J203SEN
- QMP11J203SENHT
- QMP11J203SEO
- QMP11J203SET
- QMP11J203SM
- QMP11J203SN
- QMP11J203SO



QMP11J203ST

Locking Style

Eccentric

Housing Construction

Two-Bolt Pillow Block

UPC Code

0883450081023
0883450081030
0883450081054
0883450081061
0883450081078
0883450081085
0883450081092
0883450081108
0883450154376
0883450154710
0883450249324
0883450249669
0883450960533

Dimensions**Dimension A**

2-1/2 in
63.5 mm

Dimension B

5-1/4 in
133.4 mm

Dimension C

2.99 in
75.9 mm

Dimension D Min

6.5 in
165.1 mm

Dimension D Max

7.88 in
200.2 mm

Dimension F

9.63 in
244.6 mm

Dimension G

2.63 in
66.8 mm

Dimension H	1-1/4 in 31.8 mm
Dimension J (Bolt Size)	0.625 in 16 mm
Dimension K	1.13 in 28.7 mm
Dimension L	3.31 in 84.1 mm
Dimension M	2 in 50.8 mm
Dimension R	0.19 in 4.8 mm
Dimension S	3.13 in 79.5 mm

Radial and Thrust Factors

C0 - Static Load	31900 lbf 142000 N
C - Dynamic Load (Basic)	31400 lbf 140000 N
e - Geometry Factor	0.23
Y1 - Geometry Factor	2.95
Y2 - Geometry Factor	4.40

Engineering Seal Speed

Oil Lubrication - M/N Seal	2200 rpm
Oil Lubrication - T Seal	3800 rpm
Oil Lubrication - B/C/O Seal	1600 rpm

Grease Lubrication - M/N Seal	2200 rpm
--------------------------------------	----------

Grease Lubrication - T Seal	3200 rpm
------------------------------------	----------

Grease Lubrication - B/C/O Seal	1600 rpm
--	----------

Engineering Bearing Attributes

Float	0.050 in 1.270 mm
--------------	----------------------

Shaft Tolerance	0.0015 in 0.038 mm
------------------------	-----------------------

Engineering Internal Radial Clearance

Eng Internal Radial Clearance - Min	0.0016
--	--------

Eng Internal Radial Clearance - Max	0.0026
--	--------

Pre Install Clearance Min	0.0016 in 0.040 mm
----------------------------------	-----------------------

Pre Install Clearance Max	0.0026 in 0.065 mm
----------------------------------	-----------------------

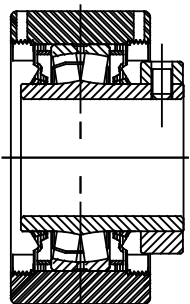
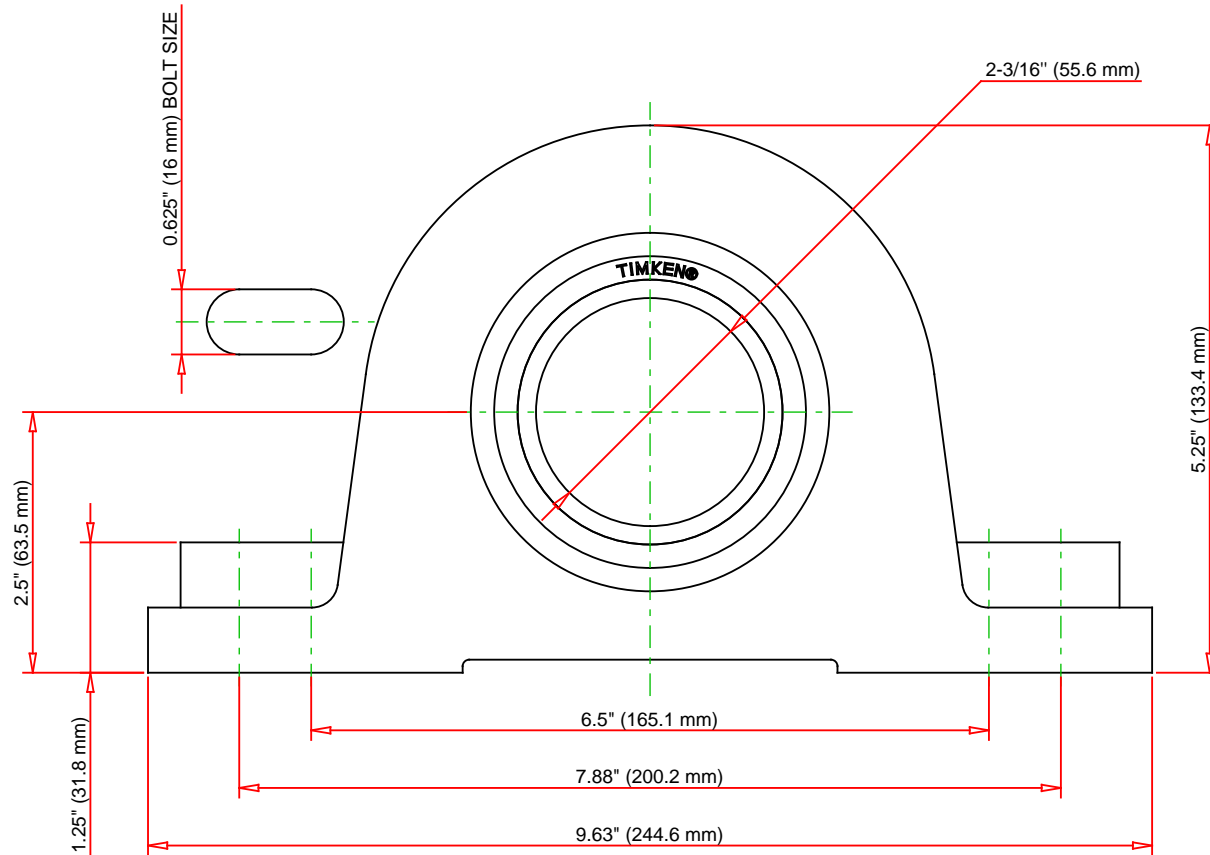
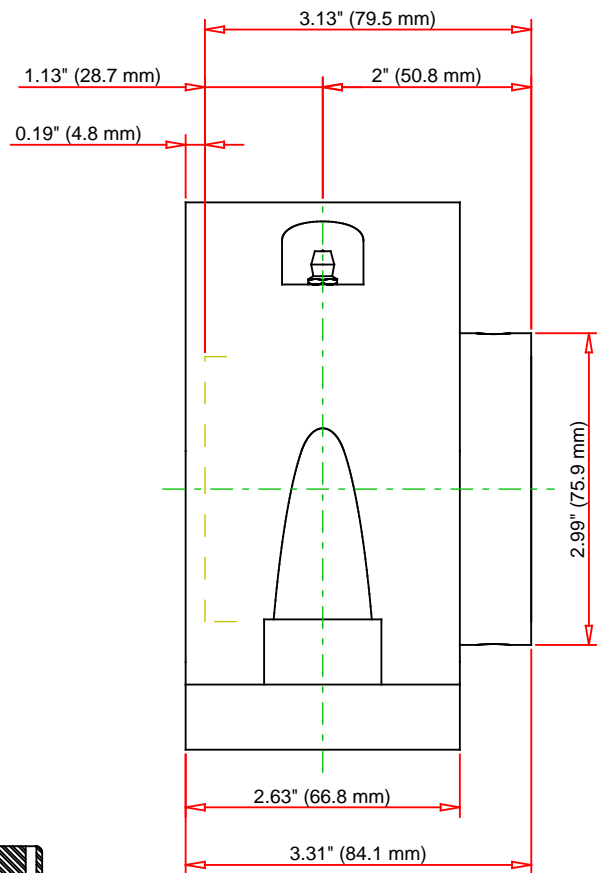

Note: Section View not to Scale

C - Dynamic Load	31400	lbf	140000	N
C0 - Static Load	31900	lbf	142000	N
Weight	17	lb	7.7	kg
Max. Speed T-Seals & Grease	3200	rpm		
Rad. Clearance - Max.	0.0026			

TIMKEN

THE TIMKEN COMPANY
NORTH CANTON, OHIO USA

QMP11J203S
Eccentric Two-Bolt Pillow Block

Every reasonable effort has been made to ensure the accuracy of the information contained in this writing, but no liability is accepted for errors, omissions or for any other reason.

FOR DISCUSSION ONLY