



The Timken Company

4500 Mt Pleasant St. NW

N. Canton, OH 44720

Phone: (234) 262-3000

E-Mail: CustomerCAD@timken.com • **Web site:** www.timken.com

Part Number QVC14V065S, Single V-Lock Piloted Flange Cartridge

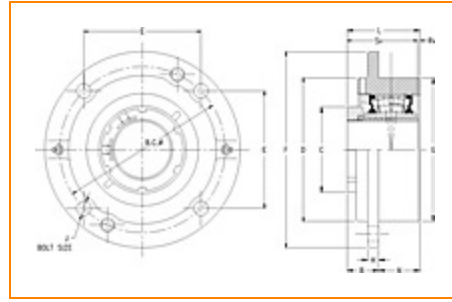
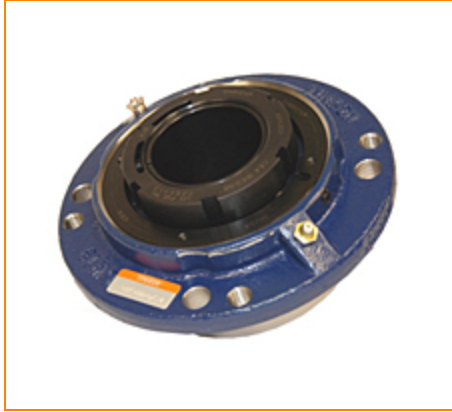

[Specifications](#) | [Dimensions](#) | [Radial and Thrust Factors](#) | [Engineering Seal Speed](#) | [Engineering Bearing Attributes](#) | [Engineering Internal Radial Clearance](#)

Specifications

Engineering Group Mounted Bearing

Bearing Number 22214

Shaft Size 65 mm

Shaft Size Type Metric

Full Timken Part Number

- QVC14V065SB
- QVC14V065SC
- QVC14V065SEB
- QVC14V065SEC
- QVC14V065SEM
- QVC14V065SEN
- QVC14V065SEO
- QVC14V065SET
- QVC14V065SM
- QVC14V065SN
- QVC14V065SO
- QVC14V065ST



Locking Style	Single V-Lock
Housing Construction	Piloted Flange Cartridge

UPC Code	0883450037198
	0883450061230
	0883450104838
	0883450104876
	0883450184052
	0883450212984
	0883450213363
	0883450225403
	0883450225786
	0883450237826
0883450238205	
0883450295239	

Dimensions

Dimension BC 6-1/2 in
165.1 mm

Dimension C 3.7 in
94 mm

Dimension D 5.5 in
139.7 mm

Dimension E 4.6 in
116.8 mm

Dimension B Exp 2.29 in
58.2 mm

Dimension B Fix 2.21 in
56.1 mm

Dimension F 7.63 in
193.8 mm

Dimension H 0.69 in
17.5 mm

Dimension J (Bolt Size)	0.5 in 12 mm
Dimension L	3.33 in 84.6 mm
Dimension RV	0.15 in 3.8 mm
Dimension SV	3.19 in 81 mm
Dimension G	5.5 in 139.7 mm
Dimension N	1.13 in 28.7 mm

Radial and Thrust Factors

C0 - Static Load	52000 lbf 231000 N
C - Dynamic Load (Basic)	47800 lbf 213000 N
e - Geometry Factor	0.23
Y1 - Geometry Factor	2.90
Y2 - Geometry Factor	4.32

Engineering Seal Speed

Oil Lubrication - M/N Seal	1700 rpm
Oil Lubrication - T Seal	3050 rpm
Oil Lubrication - B/C/O Seal	1400 rpm
Grease Lubrication - M/N Seal	1700 rpm

Grease Lubrication - T Seal	2600 rpm
------------------------------------	----------

Grease Lubrication - B/C/O Seal	1400 rpm
--	----------

Engineering Bearing Attributes

Float	0.083 in 2.108 mm
--------------	----------------------

Shaft Tolerance	0.0015 in 0.038 mm
------------------------	-----------------------

Engineering Internal Radial Clearance

Pre Install Clearance Min	0.0030 in 0.075 mm
----------------------------------	-----------------------

Pre Install Clearance Max	0.0037 in 0.095 mm
----------------------------------	-----------------------

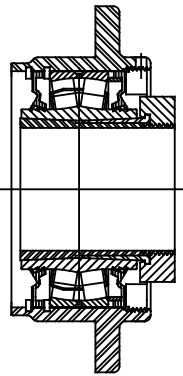
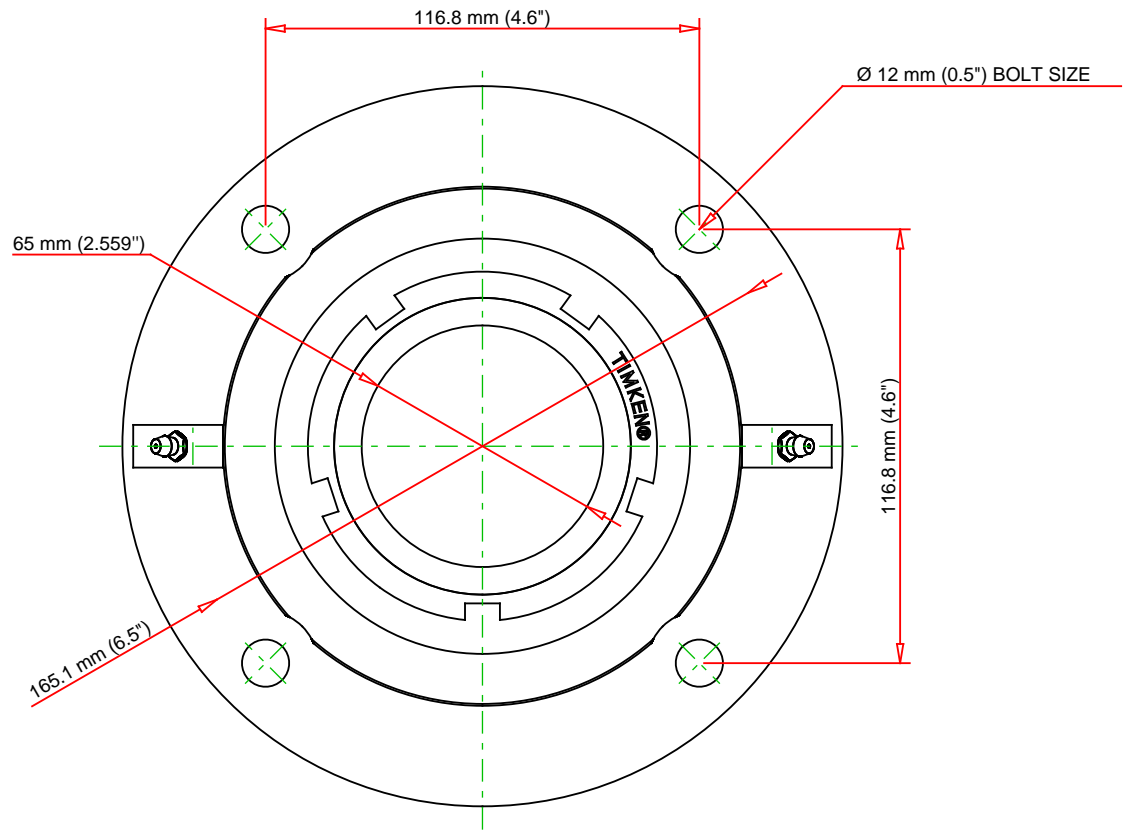
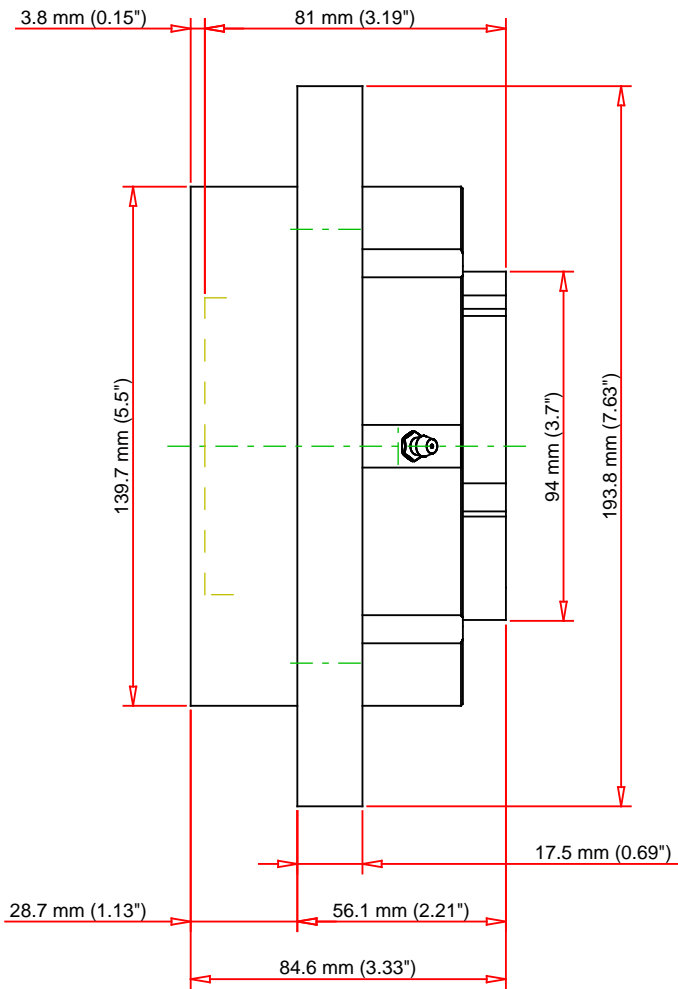

Note: Section View not to Scale

C - Dynamic Load	47800	lbf	213000	N
C0 - Static Load	52000	lbf	231000	N
Weight	16	lb	7.3	kg
Max. Speed T-Seals & Grease	2600	rpm		
Rad. Clearance - Max.	0.0037			

TIMKEN

THE TIMKEN COMPANY
NORTH CANTON, OHIO USA

QVC14V065S

Single V-Lock Piloted Flange Cartridge

Every reasonable effort has been made to ensure the accuracy of the information contained in this writing, but no liability is accepted for errors, omissions or for any other reason.

FOR DISCUSSION ONLY