



The Timken Company

4500 Mt Pleasant St. NW

N. Canton, OH 44720

Phone: (234) 262-3000

E-Mail: CustomerCAD@timken.com • **Web site:** www.timken.com

Part Number QVC12V203S, Single V-Lock Piloted Flange Cartridge

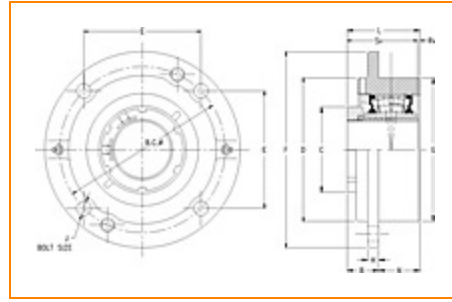
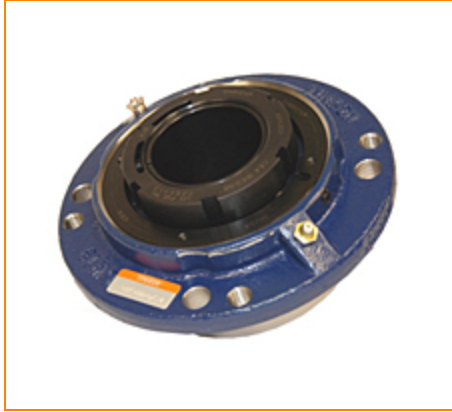

[Specifications](#) | [Dimensions](#) | [Radial and Thrust Factors](#) | [Engineering Seal Speed](#) | [Engineering Bearing Attributes](#) | [Engineering Internal Radial Clearance](#)

Specifications

Engineering Group Mounted Bearing

Bearing Number 22212

Shaft Size 2 3/16 in

Shaft Size Type Imperial

Full Timken Part Number

- QVC12V203SB
- QVC12V203SC
- QVC12V203SEB
- QVC12V203SEC
- QVC12V203SEM
- QVC12V203SEN
- QVC12V203SEO
- QVC12V203SET
- QVC12V203SM
- QVC12V203SN
- QVC12V203SO
- QVC12V203ST



| | |
|-----------------------------|--------------------------|
| Locking Style | Single V-Lock |
| Housing Construction | Piloted Flange Cartridge |

| | |
|-----------------|---------------|
| UPC Code | 0883450090018 |
| | 0883450090445 |
| | 0883450101356 |
| | 0883450101820 |
| | 0883450108904 |
| | 0883450109048 |
| | 0883450116763 |
| | 0883450117210 |
| | 0883450130974 |
| | 0883450131391 |
| 0883450139465 | |
| 0883450139557 | |

Dimensions

| | |
|---------------------|------------------|
| Dimension BC | 6 in 152.4 mm |
|---------------------|------------------|

| | |
|--------------------|--------------------|
| Dimension C | 3.16 in 80.3 mm |
|--------------------|--------------------|

| | |
|--------------------|----------------|
| Dimension D | 5 in 127 mm |
|--------------------|----------------|

| | |
|--------------------|---------------------|
| Dimension E | 4.24 in 107.7 mm |
|--------------------|---------------------|

| | |
|------------------------|--------------------|
| Dimension B Exp | 2.10 in 53.3 mm |
|------------------------|--------------------|

| | |
|------------------------|--------------------|
| Dimension B Fix | 2.02 in 51.3 mm |
|------------------------|--------------------|

| | |
|--------------------|--------------------|
| Dimension F | 7.3 in 185.4 mm |
|--------------------|--------------------|

| | |
|--------------------|--------------------|
| Dimension H | 0.58 in 14.7 mm |
|--------------------|--------------------|

| | |
|--------------------------------|--------------------|
| Dimension J (Bolt Size) | 0.5 in 12 mm |
| Dimension L | 3.15 in 80 mm |
| Dimension RV | 0.01 in 0.3 mm |
| Dimension SV | 3.14 in 79.8 mm |
| Dimension G | 5 in 127 mm |
| Dimension N | 1.13 in 28.7 mm |

Radial and Thrust Factors

| | |
|---------------------------------|-----------------------|
| C0 - Static Load | 39000 lbf 174000 N |
| C - Dynamic Load (Basic) | 38100 lbf 169000 N |
| e - Geometry Factor | 0.24 |
| Y1 - Geometry Factor | 2.84 |
| Y2 - Geometry Factor | 4.23 |

Engineering Seal Speed

| | |
|--------------------------------------|----------|
| Oil Lubrication - M/N Seal | 2000 rpm |
| Oil Lubrication - T Seal | 3500 rpm |
| Oil Lubrication - B/C/O Seal | 1650 rpm |
| Grease Lubrication - M/N Seal | 2000 rpm |

| | |
|------------------------------------|----------|
| Grease Lubrication - T Seal | 3000 rpm |
|------------------------------------|----------|

| | |
|--|----------|
| Grease Lubrication - B/C/O Seal | 1550 rpm |
|--|----------|

Engineering Bearing Attributes

| | |
|--------------|----------------------|
| Float | 0.050 in 1.270 mm |
|--------------|----------------------|

| | |
|------------------------|-----------------------|
| Shaft Tolerance | 0.0015 in 0.038 mm |
|------------------------|-----------------------|

Engineering Internal Radial Clearance

| | |
|--|--------|
| Eng Internal Radial Clearance - Min | 0.0030 |
|--|--------|

| | |
|--|--------|
| Eng Internal Radial Clearance - Max | 0.0037 |
|--|--------|

| | |
|----------------------------------|-----------------------|
| Pre Install Clearance Min | 0.0030 in 0.075 mm |
|----------------------------------|-----------------------|

| | |
|----------------------------------|-----------------------|
| Pre Install Clearance Max | 0.0037 in 0.094 mm |
|----------------------------------|-----------------------|

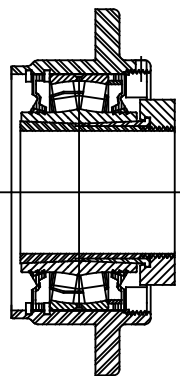
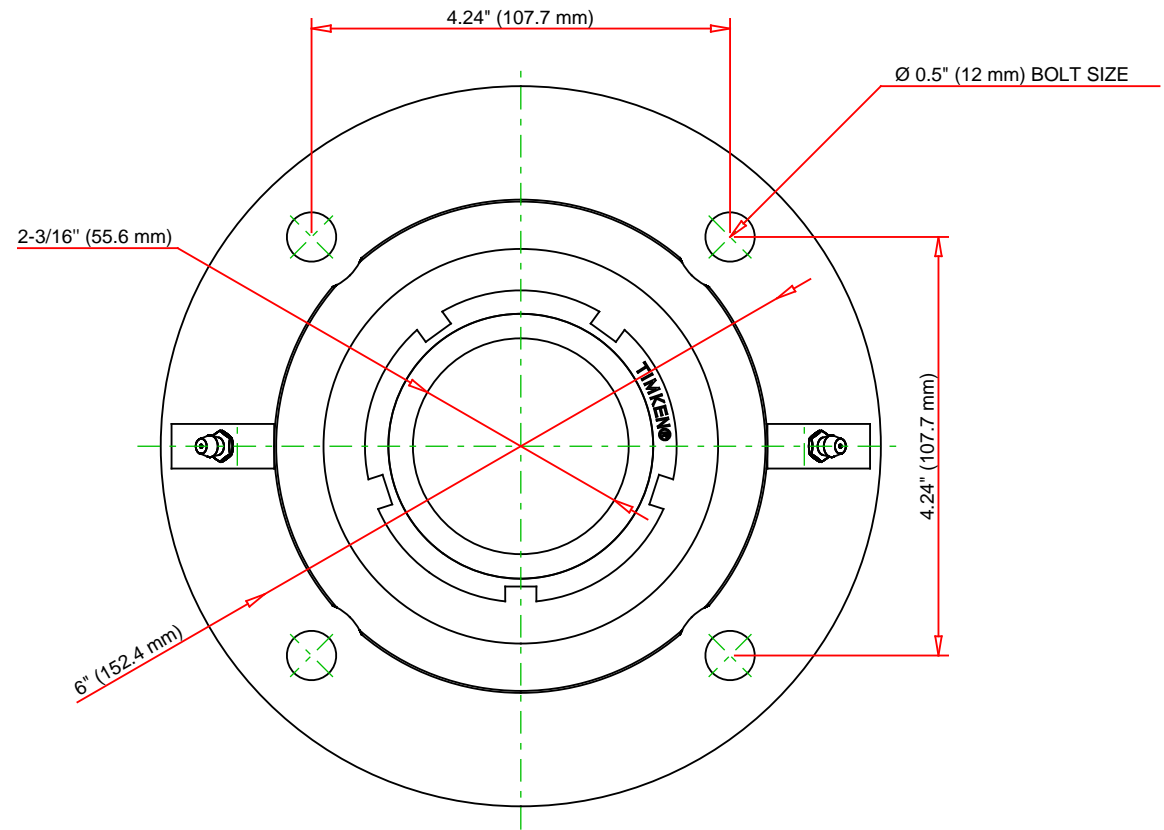
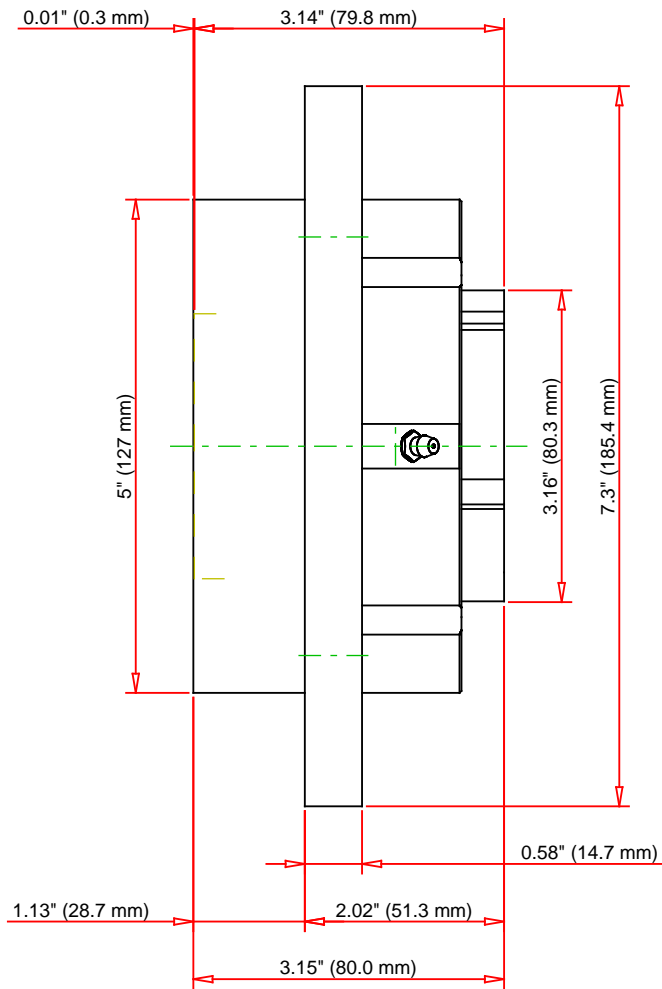

Note: Section View not to Scale

| | | | | |
|-----------------------------|--------|-----|--------|----|
| C - Dynamic Load | 38100 | lbf | 169000 | N |
| C0 - Static Load | 39000 | lbf | 174000 | N |
| Weight | 13 | lb | 5.9 | kg |
| Max. Speed T-Seals & Grease | 3000 | rpm | | |
| Rad. Clearance - Max. | 0.0037 | | | |

TIMKEN

THE TIMKEN COMPANY
NORTH CANTON, OHIO USA

QVC12V203S

Single V-Lock Piloted Flange Cartridge

Every reasonable effort has been made to ensure the accuracy of the information contained in this writing, but no liability is accepted for errors, omissions or for any other reason.

FOR DISCUSSION ONLY