



The Timken Company

4500 Mt Pleasant St. NW

N. Canton, OH 44720

Phone: (234) 262-3000

E-Mail: CustomerCAD@timken.com • **Web site:** www.timken.com

Part Number DVC20K308S, Tapered Adapter Piloted Flange Cartridge

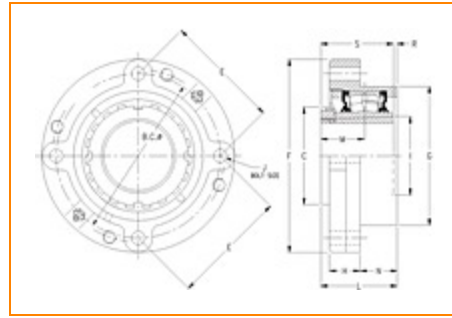

[Specifications](#) | [Dimensions](#) | [Radial and Thrust Factors](#) | [Engineering Seal Speed](#) | [Engineering Bearing Attributes](#) | [Engineering Internal Radial Clearance](#)

Specifications

Engineering Group Mounted Bearing

Bearing Number 22220

Shaft Size 3 1/2 in

Shaft Size Type Imperial

Full Timken Part Number

- DVC20K308SB
- DVC20K308SC
- DVC20K308SEB
- DVC20K308SEC
- DVC20K308SEM
- DVC20K308SEN
- DVC20K308SEO
- DVC20K308SET
- DVC20K308SM
- DVC20K308SN
- DVC20K308SO
- DVC20K308ST



Locking Style	Tapered Adapter
Housing Construction	Piloted Flange Cartridge
UPC Code	0883450004923 0883450004930 0883450004954 0883450004961 0883450004978 0883450004985 0883450004992 0883450005005 0883450196963 0883450197168 0883450274470 0883450274678

Dimensions

Dimension BC	8.63 in 219.2 mm
Dimension C	5.12 in 130 mm
Dimension E	6.1 in 154.9 mm
Dimension F	10-1/4 in 260.4 mm
Dimension G	7.375 in 187.3 mm
Dimension H	1.62 in 41.1 mm
Dimension I	4.18 in 106.2 mm
Dimension J (Bolt Size)	0.75 in 20 mm

Dimension L	3.62 in 91.9 mm
--------------------	--------------------

Dimension M	2.3 in 58.4 mm
--------------------	-------------------

Dimension N	1.38 in 35.1 mm
--------------------	--------------------

Dimension R	0.2 in 5.1 mm
--------------------	------------------

Dimension S	3.82 in 97 mm
--------------------	------------------

Radial and Thrust Factors

C0 - Static Load	113000 lbf 502000 N
-------------------------	------------------------

C - Dynamic Load (Basic)	97700 lbf 435000 N
---------------------------------	-----------------------

e - Geometry Factor	0.24
----------------------------	------

Y1 - Geometry Factor	2.85
-----------------------------	------

Y2 - Geometry Factor	4.24
-----------------------------	------

Engineering Seal Speed

Oil Lubrication - M/N Seal	1200 rpm
-----------------------------------	----------

Oil Lubrication - T Seal	2000 rpm
---------------------------------	----------

Oil Lubrication - B/C/O Seal	900 rpm
-------------------------------------	---------

Grease Lubrication - M/N Seal	1200 rpm
--------------------------------------	----------

Grease Lubrication - T Seal	1600 rpm
------------------------------------	----------

Grease Lubrication - B/C/O Seal	900 rpm
--	---------

Engineering Bearing Attributes

Float	0.083 in 2.108 mm
Shaft Tolerance	0.0040 in 0.102 mm

Engineering Internal Radial Clearance

Pre Install Clearance Min	0.0043 in 0.110 mm
Pre Install Clearance Max	0.0055 in 0.140 mm

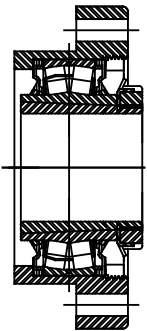
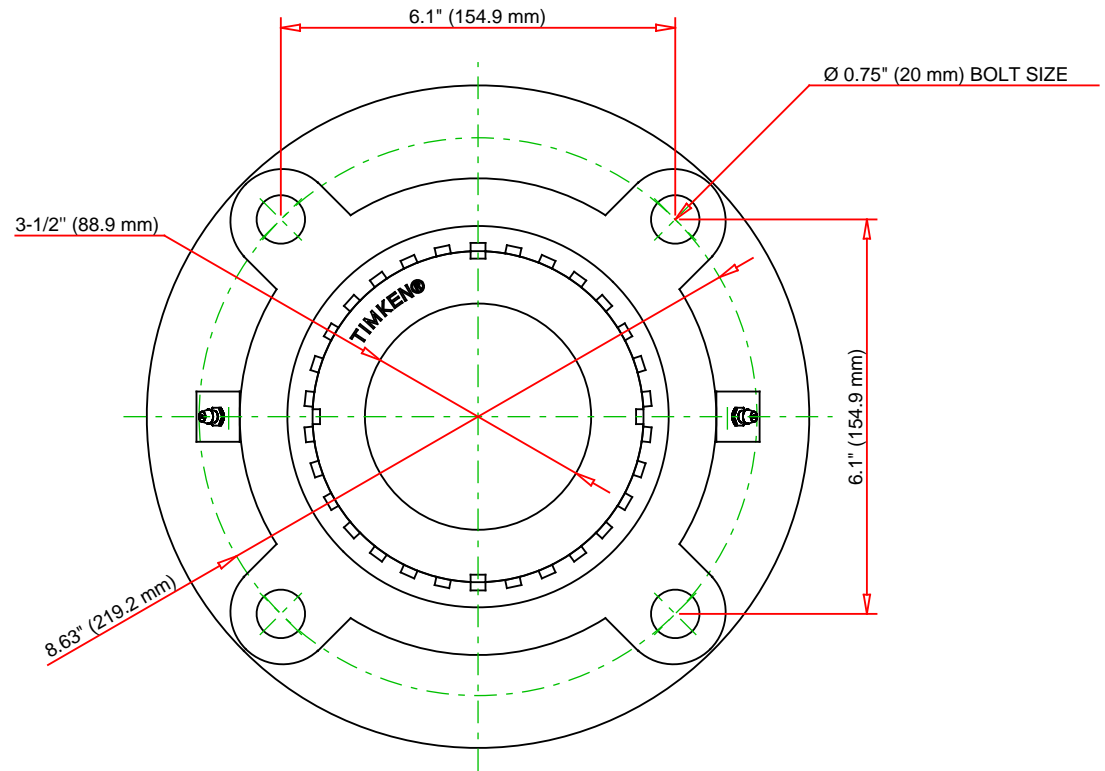
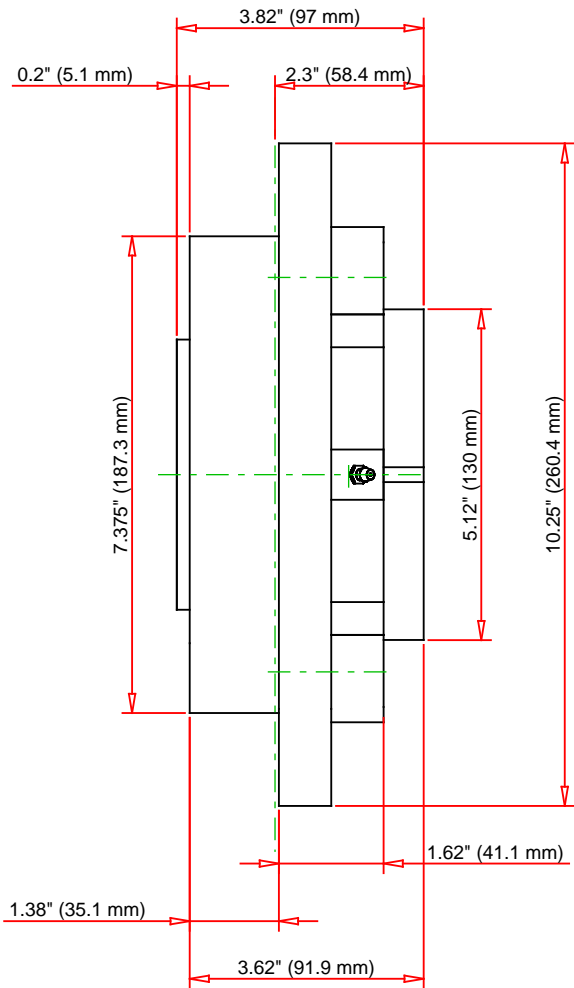

Note: Section View not to Scale

C - Dynamic Load	97700	lbf	435000	N
C0 - Static Load	113000	lbf	502000	N
Weight	37	lb	16.8	kg
Max. Speed T-Seals & Grease	1600	rpm		
Rad. Clearance - Max.				

TIMKEN

THE TIMKEN COMPANY
NORTH CANTON, OHIO USA

DVC20K308S

Tapered Adapter Piloted Flange
Cartridge

Every reasonable effort has been made to ensure the accuracy of the information contained in this writing, but no liability is accepted for errors, omissions or for any other reason.

FOR DISCUSSION ONLY