



**The Timken Company**

4500 Mt Pleasant St. NW

N. Canton, OH 44720

**Phone:** (234) 262-3000

**E-Mail:** [CustomerCAD@timken.com](mailto:CustomerCAD@timken.com) • **Web site:** [www.timken.com](http://www.timken.com)

## Part Number QAMC20A315S, Single Concentric Cartridge Block

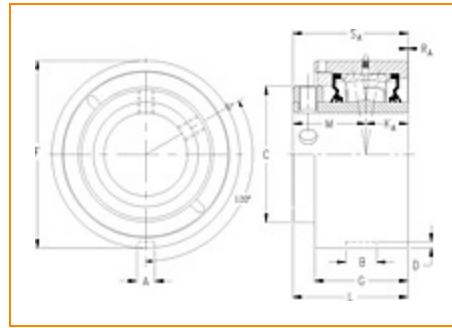

[Specifications](#) | [Dimensions](#) | [Radial and Thrust Factors](#) | [Engineering Seal Speed](#) | [Engineering Bearing Attributes](#) | [Engineering Internal Radial Clearance](#)

### Specifications

**Engineering Group** Mounted Bearing

**Bearing Number** 22220

**Shaft Size** 3 15/16 in

**Shaft Size Type** Imperial

**Full Timken Part Number**

- QAMC20A315SB
- QAMC20A315SC
- QAMC20A315SEB
- QAMC20A315SEC
- QAMC20A315SEM
- QAMC20A315SEN
- QAMC20A315SEO
- QAMC20A315SET
- QAMC20A315SM
- QAMC20A315SN
- QAMC20A315SO
- QAMC20A315ST



<b>Locking Style</b>	Single Concentric
----------------------	-------------------

<b>Housing Construction</b>	Cartridge
-----------------------------	-----------

<b>UPC Code</b>	0883450044004
	0883450044011
	0883450044035
	0883450044042
	0883450044059
	0883450044066
	0883450044073
	0883450044080
	0883450194631
	0883450194792
	0883450271806
0883450271967	

## Dimensions

<b>Dimension A</b>	0.78 in 19.8 mm
--------------------	--------------------

<b>Dimension B</b>	1.28 in 32.5 mm
--------------------	--------------------

<b>Dimension C</b>	6 in 152.4 mm
--------------------	------------------

<b>Dimension D</b>	0.31 in 7.9 mm
--------------------	-------------------

<b>Dimension F</b>	8.1250 in 206.4 mm
--------------------	-----------------------

<b>Dimension G</b>	4.14 in 105.2 mm
--------------------	---------------------

<b>Dimension KA</b>	1.63 in 41.4 mm
---------------------	--------------------

<b>Dimension L Exp</b>	5.13 in 130.3 mm
------------------------	---------------------

<b>Dimension L Fix</b>	5.05 in 128.3 mm
------------------------	---------------------

<b>Dimension M</b>	2.97 in 75.4 mm
--------------------	--------------------

<b>Dimension RA</b>	0.45 in 11.4 mm
---------------------	--------------------

<b>Dimension SA</b>	4.59 in 116.6 mm
---------------------	---------------------

## Radial and Thrust Factors

<b>C0 - Static Load</b>	113000 lbf 502000 N
-------------------------	------------------------

<b>C - Dynamic Load (Basic)</b>	97700 lbf 435000 N
---------------------------------	-----------------------

<b>e - Geometry Factor</b>	0.24
----------------------------	------

<b>Y1 - Geometry Factor</b>	2.85
-----------------------------	------

<b>Y2 - Geometry Factor</b>	4.24
-----------------------------	------

## Engineering Seal Speed

<b>Oil Lubrication - M/N Seal</b>	1200 rpm
-----------------------------------	----------

<b>Oil Lubrication - T Seal</b>	2000 rpm
---------------------------------	----------

<b>Oil Lubrication - B/C/O Seal</b>	900 rpm
-------------------------------------	---------

<b>Grease Lubrication - M/N Seal</b>	1200 rpm
--------------------------------------	----------

<b>Grease Lubrication - T Seal</b>	1600 rpm
------------------------------------	----------

<b>Grease Lubrication - B/C/O Seal</b>	900 rpm
----------------------------------------	---------

## Engineering Bearing Attributes

<b>Float</b>	0.083 in 2.108 mm
--------------	----------------------

<b>Shaft Tolerance</b>	0.0030 in 0.076 mm
------------------------	-----------------------

## Engineering Internal Radial Clearance

<b>Eng Internal Radial Clearance - Min</b>	0.0030
--------------------------------------------	--------

<b>Eng Internal Radial Clearance - Max</b>	0.0047
--------------------------------------------	--------

<b>Pre Install Clearance Min</b>	0.0030 in 0.075 mm
----------------------------------	-----------------------

<b>Pre Install Clearance Max</b>	0.0047 in 0.120 mm
----------------------------------	-----------------------

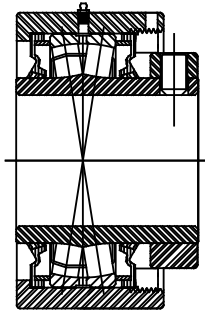
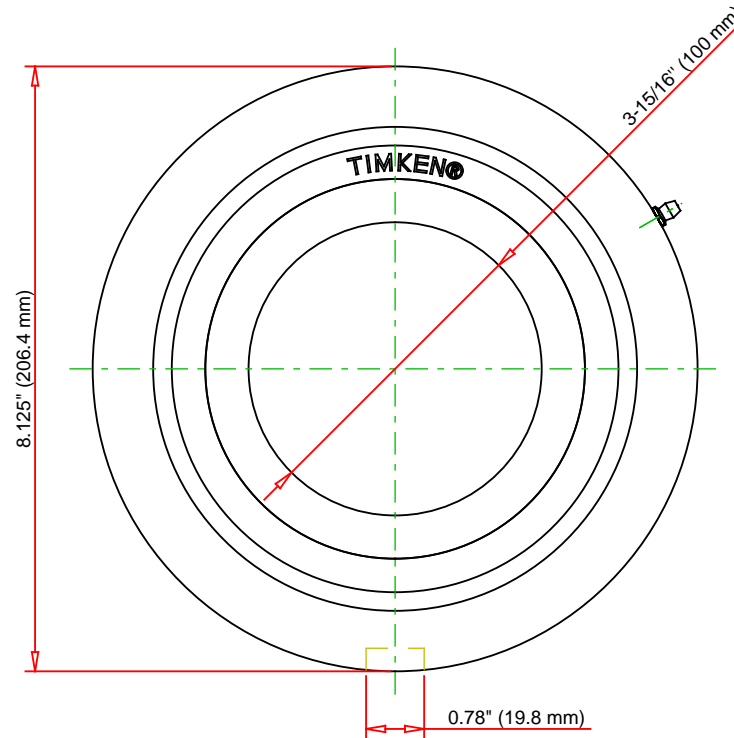
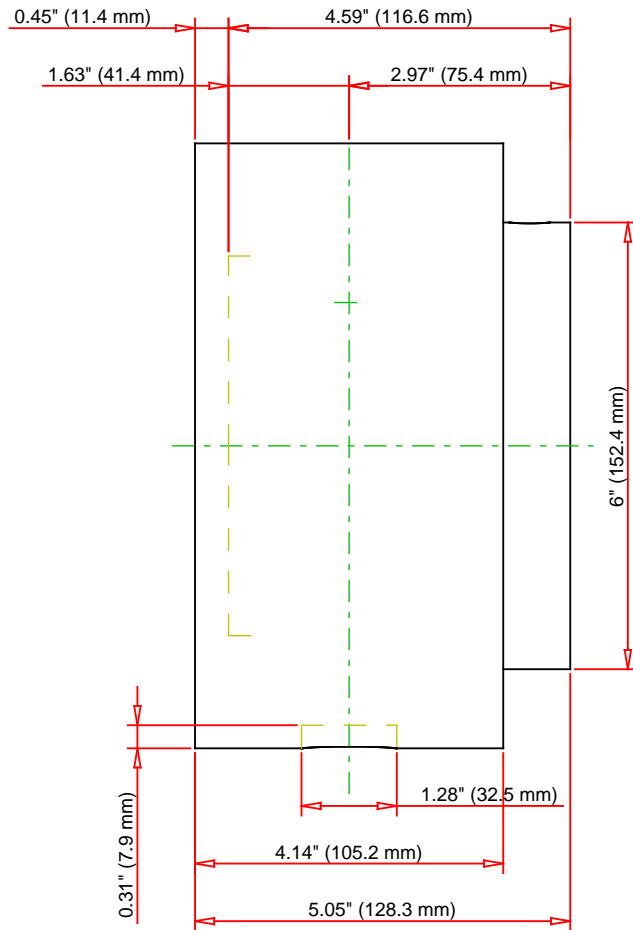

Note: Section View not to Scale

C - Dynamic Load	97700	lbf	435000	N
C0 - Static Load	113000	lbf	502000	N
Weight	32	lb	14.5	kg
Max. Speed T-Seals & Grease	1600	rpm		
Rad. Clearance - Max.	0.0047			

**TIMKEN**

THE TIMKEN COMPANY  
NORTH CANTON, OHIO USA

**QAMC20A315S**  
Single Concentric Cartridge Block

Every reasonable effort has been made to ensure the accuracy of the information contained in this writing, but no liability is accepted for errors, omissions or for any other reason.

**FOR DISCUSSION ONLY**