



The Timken Company

4500 Mt Pleasant St. NW

N. Canton, OH 44720

Phone: (234) 262-3000

E-Mail: CustomerCAD@timken.com • **Web site:** www.timken.com

Part Number QMPR18J304S, Eccentric Four-Bolt Pillow Block

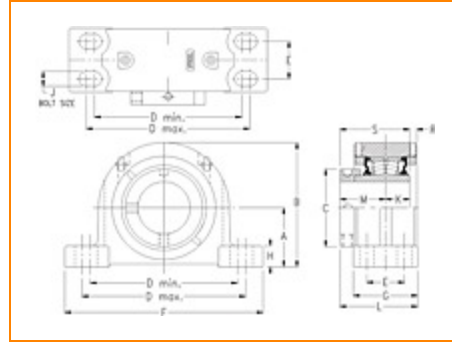
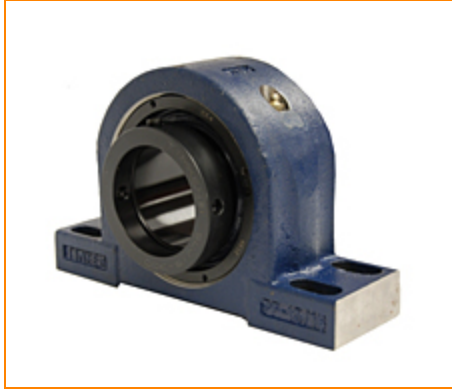

[Specifications](#) | [Dimensions](#) | [Radial and Thrust Factors](#) | [Engineering Seal Speed](#) | [Engineering Bearing Attributes](#) | [Engineering Internal Radial Clearance](#)

Specifications

Engineering Group Mounted Bearing

Bearing Number 22218

Shaft Size 3 1/4 in

Shaft Size Type Imperial

Full Timken Part Number

- QMPR18J304SB
- QMPR18J304SC
- QMPR18J304SEB
- QMPR18J304SEC
- QMPR18J304SEM
- QMPR18J304SEN
- QMPR18J304SEO
- QMPR18J304SET
- QMPR18J304SM
- QMPR18J304SN
- QMPR18J304SO
- QMPR18J304ST



Locking Style	Eccentric
Housing Construction	Four-Bolt Pillow Block
UPC Code	0883450090629 0883450090636 0883450090650 0883450090667 0883450090674 0883450090681 0883450090698 0883450090704 0883450157223 0883450157421 0883450251549 0883450251716

Dimensions

Dimension A	3-3/4 in 95.3 mm
Dimension B	7.69 in 195.3 mm
Dimension C	4.76 in 120.9 mm
Dimension D Min	9.25 in 235 mm
Dimension D Max	11.25 in 285.8 mm
Dimension E	2.38 in 60.5 mm
Dimension F	13.63 in 346.2 mm
Dimension G	3.75 in 95.3 mm

Dimension H	1.56 in 39.6 mm
--------------------	--------------------

Dimension J (Bolt Size)	0.75 in 20 mm
--------------------------------	------------------

Dimension K	1.44 in 36.6 mm
--------------------	--------------------

Dimension L	4.46 in 113.3 mm
--------------------	---------------------

Dimension M	2.59 in 65.8 mm
--------------------	--------------------

Dimension R	0.32 in 8.1 mm
--------------------	-------------------

Dimension S	4.03 in 102.4 mm
--------------------	---------------------

Radial and Thrust Factors

C0 - Static Load	87200 lbf 388000 N
-------------------------	-----------------------

C - Dynamic Load (Basic)	79700 lbf 355000 N
---------------------------------	-----------------------

e - Geometry Factor	0.23
----------------------------	------

Y1 - Geometry Factor	2.90
-----------------------------	------

Y2 - Geometry Factor	4.31
-----------------------------	------

Engineering Seal Speed

Oil Lubrication - M/N Seal	1400 rpm
-----------------------------------	----------

Oil Lubrication - T Seal	2400 rpm
---------------------------------	----------

Oil Lubrication - B/C/O Seal	1000 rpm
-------------------------------------	----------

Grease Lubrication - M/N Seal	1400 rpm
--------------------------------------	----------

Grease Lubrication - T Seal	2000 rpm
------------------------------------	----------

Grease Lubrication - B/C/O Seal	1000 rpm
--	----------

Engineering Bearing Attributes

Float	0.083 in
	2.108 mm

Shaft Tolerance	0.0030 in
	0.076 mm

Engineering Internal Radial Clearance

Eng Internal Radial Clearance - Min	0.0024
--	--------

Eng Internal Radial Clearance - Max	0.0039
--	--------

Pre Install Clearance Min	0.0024 in
	0.060 mm

Pre Install Clearance Max	0.0039 in
	0.100 mm

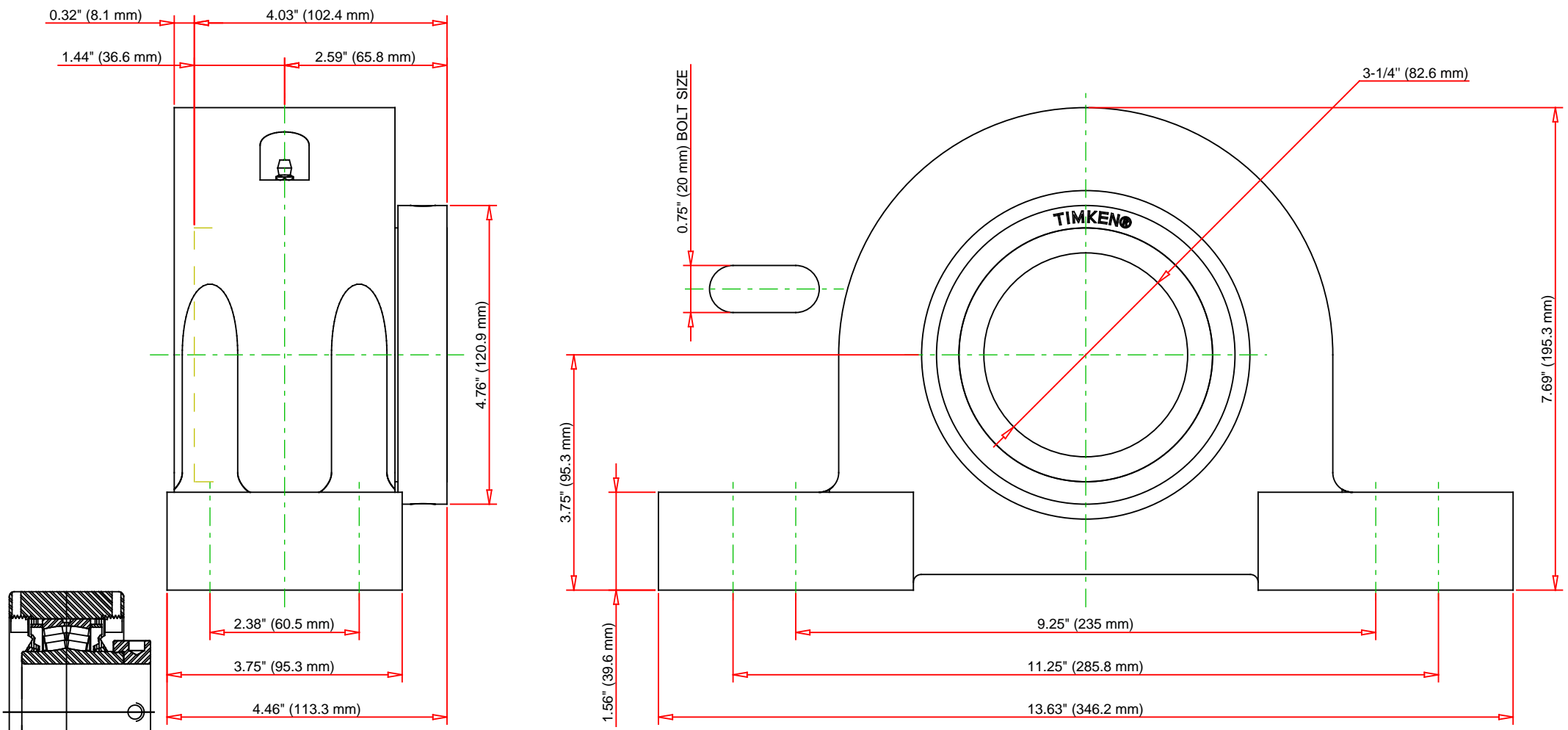

Note: Section View not to Scale

C - Dynamic Load	79700	lbf	355000	N
C0 - Static Load	87200	lbf	388000	N
Weight	49	lb	22.2	kg
Max. Speed T-Seals & Grease	2000	rpm		
Rad. Clearance - Max.	0.0039			



THE TIMKEN COMPANY
NORTH CANTON, OHIO USA

QMPR18J304S
Eccentric Four-Bolt Pillow Block

Every reasonable effort has been made to ensure the accuracy of the information contained in this writing, but no liability is accepted for errors, omissions or for any other reason.

FOR DISCUSSION ONLY