



The Timken Company

4500 Mt Pleasant St. NW

N. Canton, OH 44720

Phone: (234) 262-3000

E-Mail: CustomerCAD@timken.com • **Web site:** www.timken.com

Part Number QAMC13A208S, Single Concentric Cartridge Block

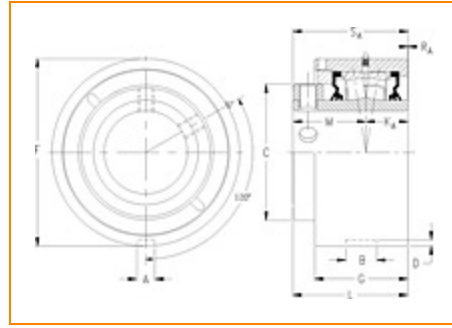

[Specifications](#) | [Dimensions](#) | [Radial and Thrust Factors](#) | [Engineering Seal Speed](#) | [Engineering Bearing Attributes](#) | [Engineering Internal Radial Clearance](#)

Specifications

Engineering Group Mounted Bearing

Bearing Number 22213

Shaft Size 2 1/2 in

Shaft Size Type Imperial

Full Timken Part Number

- QAMC13A208SB
- QAMC13A208SC
- QAMC13A208SEB
- QAMC13A208SEC
- QAMC13A208SEM
- QAMC13A208SEN
- QAMC13A208SEO
- QAMC13A208SET
- QAMC13A208SM
- QAMC13A208SMT
- QAMC13A208SN
- QAMC13A208SO



QAMC13A208ST

Locking Style	Single Concentric
Housing Construction	Cartridge
UPC Code	0883450043304 0883450043311 0883450043335 0883450043342 0883450043359 0883450043366 0883450043373 0883450043380 0883450194556 0883450194716 0883450271721 0883450271882 0883450964548

Dimensions

Dimension A	0.53 in 13.5 mm
Dimension B	0.91 in 23.1 mm
Dimension C	3.81 in 96.8 mm
Dimension D	0.19 in 4.8 mm
Dimension F	5 in 127 mm
Dimension G	2.73 in 69.3 mm
Dimension KA	1.24 in 31.5 mm

Dimension L Exp	3.46 in 87.9 mm
Dimension L Fix	3.38 in 85.9 mm
Dimension M	2.15 in 54.6 mm
Dimension RA	0 in 0 mm
Dimension SA	3.39 in 86.1 mm

Radial and Thrust Factors

C0 - Static Load	48600 lbf 216000 N
C - Dynamic Load (Basic)	46400 lbf 206000 N
e - Geometry Factor	0.24
Y1 - Geometry Factor	2.79
Y2 - Geometry Factor	4.15

Engineering Seal Speed

Oil Lubrication - M/N Seal	1800 rpm
Oil Lubrication - T Seal	3200 rpm
Oil Lubrication - B/C/O Seal	1500 rpm
Grease Lubrication - M/N Seal	1800 rpm
Grease Lubrication - T Seal	2800 rpm
Grease Lubrication - B/C/O Seal	1500 rpm

Engineering Bearing Attributes

Float	0.083 in 2.108 mm
Shaft Tolerance	0.0015 in 0.038 mm

Engineering Internal Radial Clearance

Eng Internal Radial Clearance - Min	0.0016
Eng Internal Radial Clearance - Max	0.0026
Pre Install Clearance Min	0.0016 in 0.040 mm
Pre Install Clearance Max	0.0026 in 0.065 mm

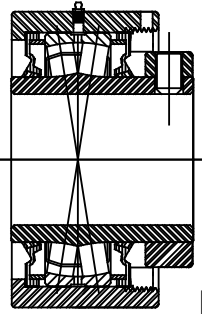
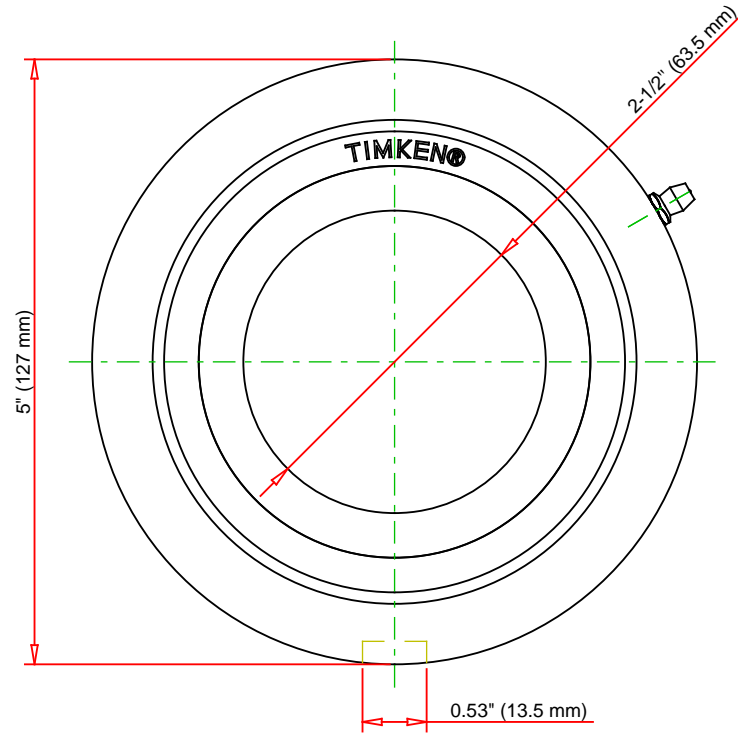
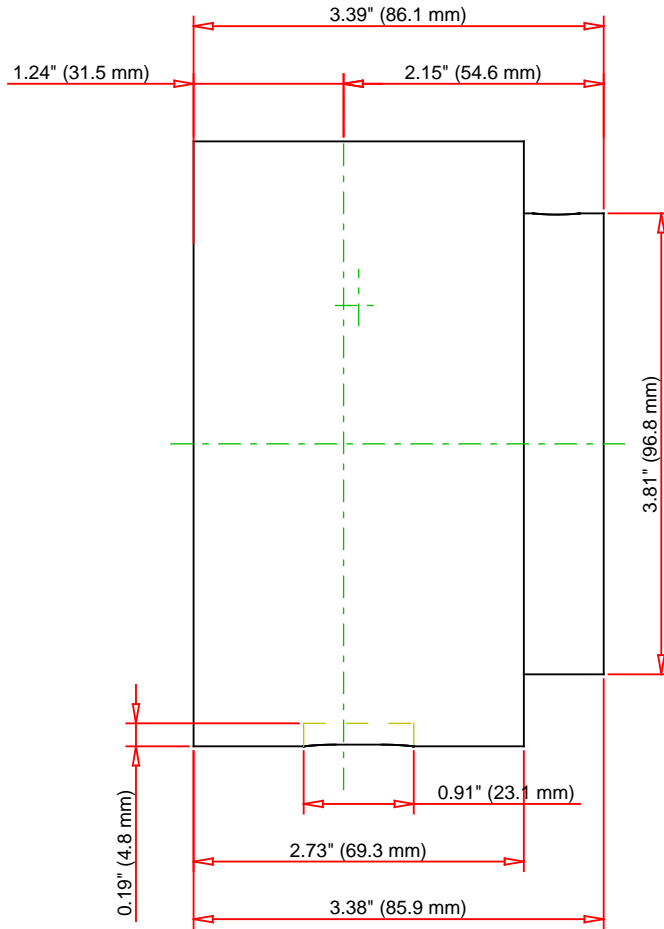

Note: Section View not to Scale

C - Dynamic Load	46400	lbf	206000	N
C0 - Static Load	48600	lbf	216000	N
Weight	12	lb	5.4	kg
Max. Speed T-Seals & Grease	2800	rpm		
Rad. Clearance - Max.	0.0026			

TIMKEN

THE TIMKEN COMPANY
NORTH CANTON, OHIO USA

QAMC13A208S
Single Concentric Cartridge Block

Every reasonable effort has been made to ensure the accuracy of the information contained in this writing, but no liability is accepted for errors, omissions or for any other reason.

FOR DISCUSSION ONLY