



The Timken Company

4500 Mt Pleasant St. NW

N. Canton, OH 44720

Phone: (234) 262-3000

E-Mail: CustomerCAD@timken.com • **Web site:** www.timken.com

Part Number QVPX19V307S, Single V-Lock Four-Bolt Pillow Block

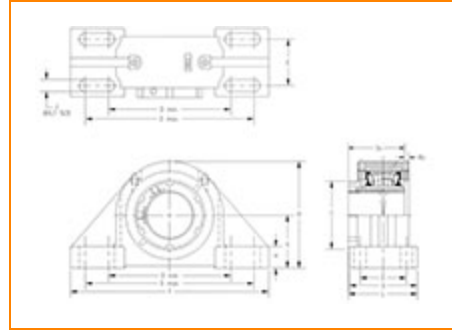
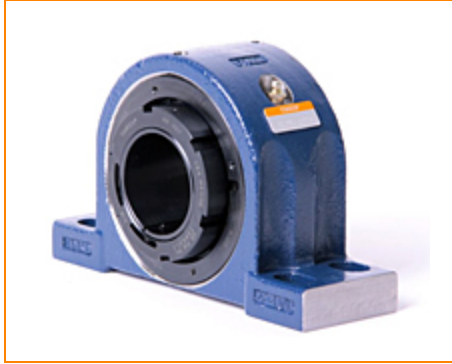

[Specifications](#) | [Dimensions](#) | [Radial and Thrust Factors](#) | [Engineering Seal Speed](#) | [Engineering Bearing Attributes](#) | [Engineering Internal Radial Clearance](#)

Specifications

Engineering Group Mounted Bearing

Bearing Number 22219

Shaft Size 3 7/16 in

Shaft Size Type Imperial

Full Timken Part Number

- QVPX19V307SB
- QVPX19V307SC
- QVPX19V307SEB
- QVPX19V307SEC
- QVPX19V307SEM
- QVPX19V307SEN
- QVPX19V307SEO
- QVPX19V307SET
- QVPX19V307SM
- QVPX19V307SN
- QVPX19V307SO
- QVPX19V307ST



Locking Style	Single V-Lock
Housing Construction	Four-Bolt Pillow Block

Dimensions

Dimension A
4 in
101.6 mm

Dimension B
7.92 in
201.2 mm

Dimension C
4.9 in
124.5 mm

Dimension D Min
10.81 in
274.6 mm

Dimension D Max
12.19 in
309.6 mm

Dimension E
3 in
76.2 mm

Dimension F
15 in
381 mm

Dimension G
4.75 in
120.7 mm

Dimension H
1 1/2 in
38.1 mm

Dimension J (Bolt Size)
0.75 in
20 mm

Dimension L
4.69 in
119.1 mm

Dimension RV
0.31 in
7.9 mm

Dimension SV
3.69 in
93.7 mm

Radial and Thrust Factors

C0 - Static Load	99000 lbf 441000 N
C - Dynamic Load (Basic)	86600 lbf 385000 N
e - Geometry Factor	0.23
Y1 - Geometry Factor	2.88
Y2 - Geometry Factor	4.29

Engineering Seal Speed

Oil Lubrication - M/N Seal	1300 rpm
Oil Lubrication - T Seal	2200 rpm
Oil Lubrication - B/C/O Seal	1000 rpm
Grease Lubrication - M/N Seal	1300 rpm
Grease Lubrication - T Seal	1800 rpm
Grease Lubrication - B/C/O Seal	950 rpm

Engineering Bearing Attributes

Float	0.083 in 2.108 mm
Shaft Tolerance	0.0030 in 0.076 mm

Engineering Internal Radial Clearance

Eng Internal Radial Clearance - Min	0.0043
Eng Internal Radial Clearance - Max	0.0055
Pre Install Clearance Min	0.0043 in 0.110 mm
Pre Install Clearance Max	0.0055 in 0.140 mm

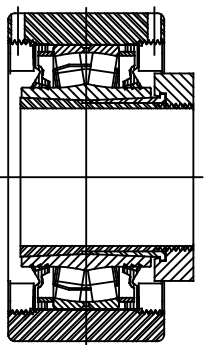
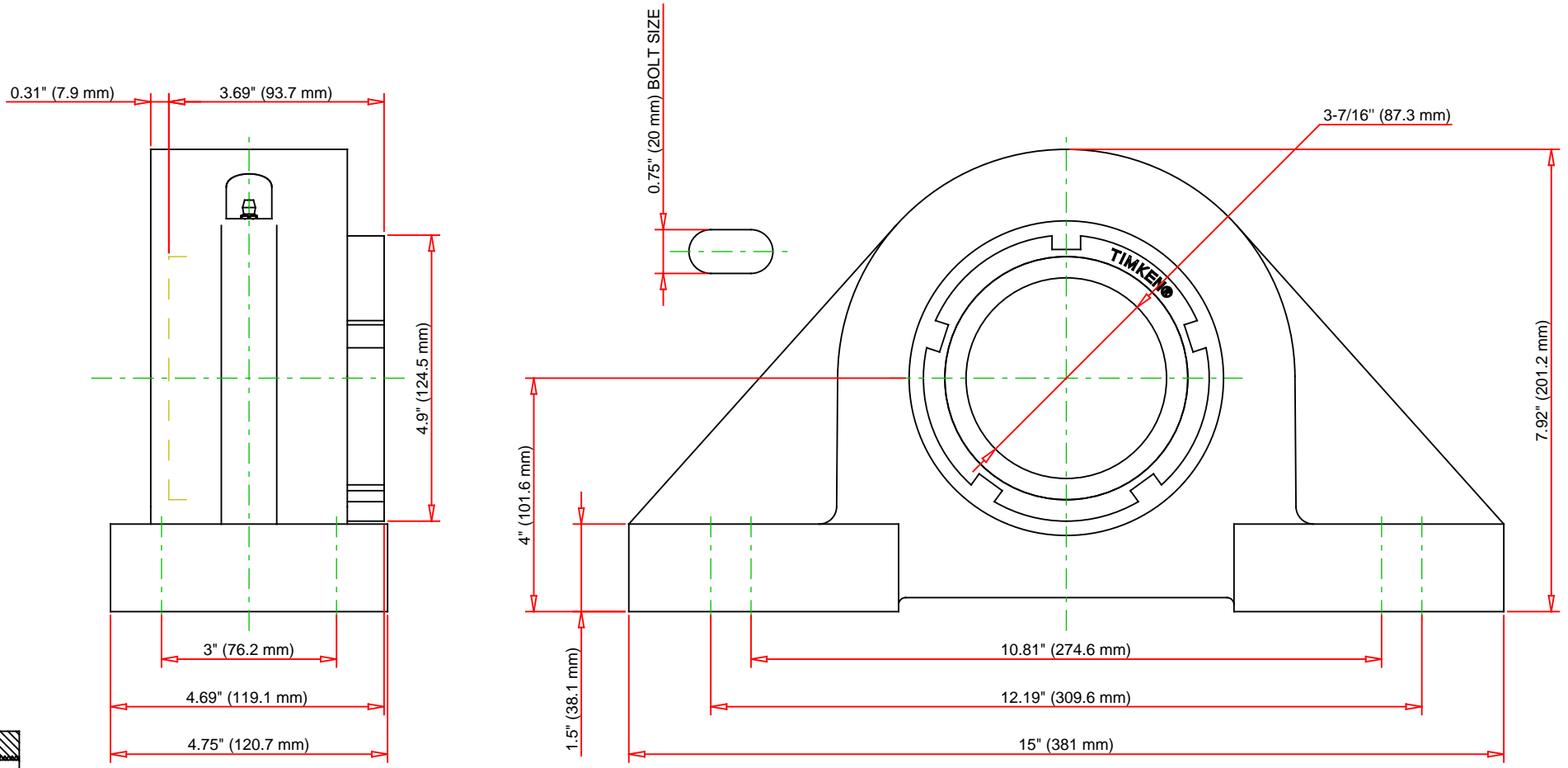

Note: Section View not to Scale

C - Dynamic Load	86600	lbf	385000	N
C0 - Static Load	99000	lbf	441000	N
Weight	49	lb	22.2	kg
Max. Speed T-Seals & Grease	1800	rpm		
Rad. Clearance - Max.	0.0055			

TIMKEN

THE TIMKEN COMPANY
NORTH CANTON, OHIO USA

QVPX19V307S
Single V-Lock Four-Bolt Pillow Block

Every reasonable effort has been made to ensure the accuracy of the information contained in this writing, but no liability is accepted for errors, omissions or for any other reason.

FOR DISCUSSION ONLY