



The Timken Company

4500 Mt Pleasant St. NW

N. Canton, OH 44720

Phone: (234) 262-3000

E-Mail: CustomerCAD@timken.com • **Web site:** www.timken.com

Part Number QVPK22V400S, Single V-Lock Four-Bolt Pillow Block

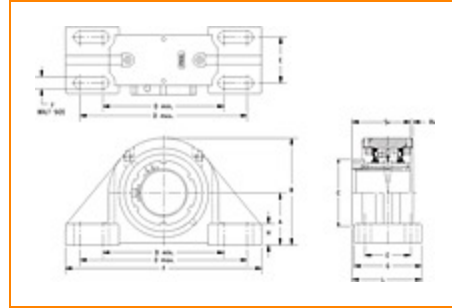
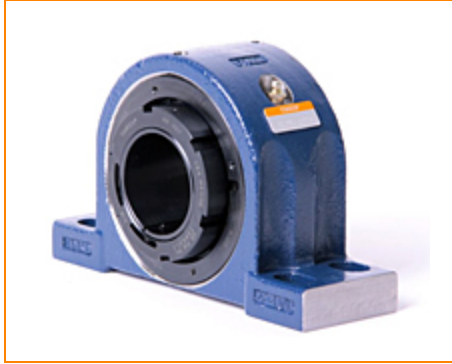

[Specifications](#) | [Dimensions](#) | [Radial and Thrust Factors](#) | [Engineering Seal Speed](#) | [Engineering Bearing Attributes](#) | [Engineering Internal Radial Clearance](#)

Specifications

Engineering Group Mounted Bearing

Bearing Number 22222

Shaft Size 4 in

Shaft Size Type Imperial

Full Timken Part Number

- QVPK22V400SB
- QVPK22V400SC
- QVPK22V400SEB
- QVPK22V400SEC
- QVPK22V400SEM
- QVPK22V400SEN
- QVPK22V400SEO
- QVPK22V400SET
- QVPK22V400SM
- QVPK22V400SN
- QVPK22V400SO
- QVPK22V400ST



Locking Style	Single V-Lock
Housing Construction	Four-Bolt Pillow Block
UPC Code	0883450055369 0883450055512 0883450207119 0883450207263 0883450219549 0883450219693 0883450231961 0883450232111 0883450240703 0883450240857 0883450245661 0883450245814

Dimensions

Dimension A	5-3/4 in 146.1 mm
Dimension B	10.78 in 273.8 mm
Dimension C	5.5 in 139.7 mm
Dimension D Min	13.94 in 354.1 mm
Dimension D Max	15.56 in 395.2 mm
Dimension E	4 in 101.6 mm
Dimension F	18-1/2 in 469.9 mm
Dimension G	6-1/4 in 158.8 mm

Dimension H	1.8 in 45.7 mm
Dimension J (Bolt Size)	1 in 24 mm
Dimension L	5.45 in 138.4 mm
Dimension RV	0.19 in 4.8 mm
Dimension SV	4.13 in 104.9 mm

Radial and Thrust Factors

C0 - Static Load	147000 lbf 653000 N
C - Dynamic Load (Basic)	125000 lbf 555000 N
e - Geometry Factor	0.25
Y1 - Geometry Factor	2.73
Y2 - Geometry Factor	4.06

Engineering Seal Speed

Oil Lubrication - M/N Seal	900 rpm
Oil Lubrication - T Seal	1700 rpm
Oil Lubrication - B/C/O Seal	600 rpm
Grease Lubrication - M/N Seal	900 rpm
Grease Lubrication - T Seal	1200 rpm
Grease Lubrication - B/C/O Seal	600 rpm

Engineering Bearing Attributes

Float	0.083 in 2.108 mm
--------------	----------------------

Shaft Tolerance	0.0030 in 0.076 mm
------------------------	-----------------------

Engineering Internal Radial Clearance

Eng Internal Radial Clearance - Min	0.0053
--	--------

Eng Internal Radial Clearance - Max	0.0067
--	--------

Pre Install Clearance Min	0.0053 in 0.135 mm
----------------------------------	-----------------------

Pre Install Clearance Max	0.0067 in 0.170 mm
----------------------------------	-----------------------

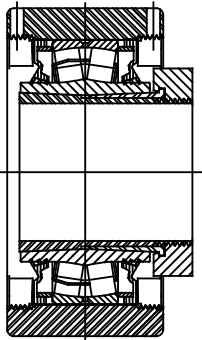
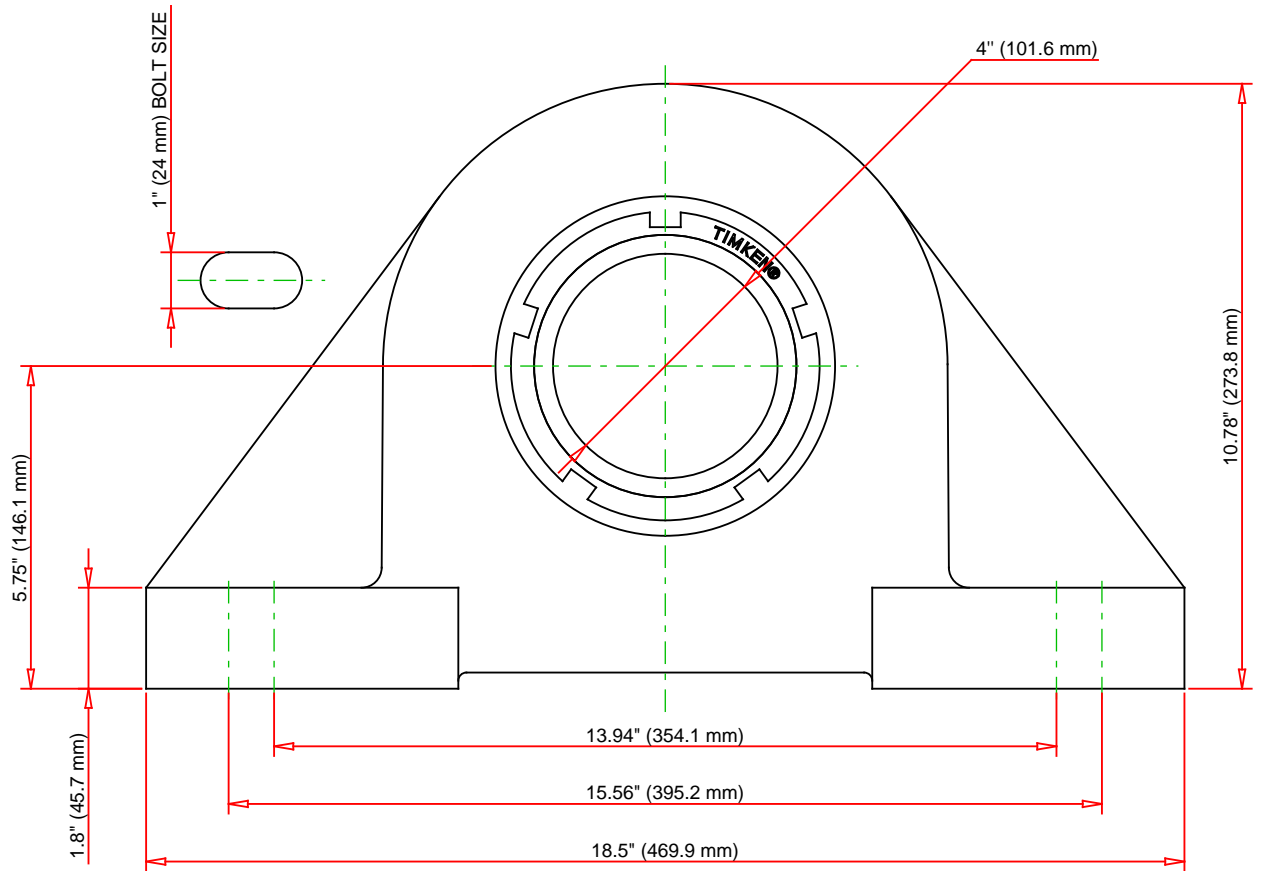
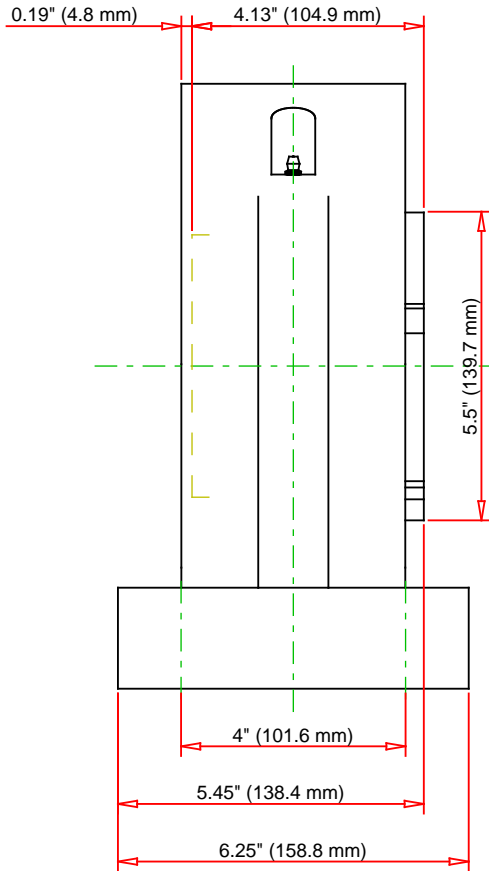

Note: Section View not to Scale

C - Dynamic Load	125000	lbf	555000	N
C0 - Static Load	147000	lbf	653000	N
Weight	87	lb	39.5	kg
Max. Speed T-Seals & Grease	1200	rpm		
Rad. Clearance - Max.	0.0067			

TIMKEN

THE TIMKEN COMPANY
NORTH CANTON, OHIO USA

QVPK22V400S
Single V-Lock Four-Bolt Pillow Block

Every reasonable effort has been made to ensure the accuracy of the information contained in this writing, but no liability is accepted for errors, omissions or for any other reason.

FOR DISCUSSION ONLY