



**The Timken Company**

4500 Mt Pleasant St. NW

N. Canton, OH 44720

**Phone:** (234) 262-3000

**E-Mail:** [CustomerCAD@timken.com](mailto:CustomerCAD@timken.com) • **Web site:** [www.timken.com](http://www.timken.com)

## Part Number QAAMC10A115S, Double Concentric Cartridge Block

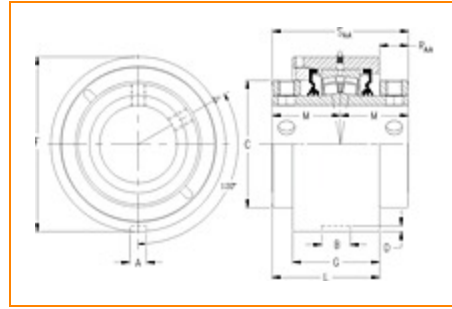

[Specifications](#) | [Dimensions](#) | [Radial and Thrust Factors](#) | [Engineering Seal Speed](#) | [Engineering Bearing Attributes](#) | [Engineering Internal Radial Clearance](#)

### Specifications

**Engineering Group** Mounted Bearing

**Bearing Number** 22210

**Shaft Size** 1 15/16 in

**Shaft Size Type** Imperial

**Full Timken Part Number**

- QAAMC10A115SB
- QAAMC10A115SC
- QAAMC10A115SEB
- QAAMC10A115SEC
- QAAMC10A115SEM
- QAAMC10A115SEN
- QAAMC10A115SEO
- QAAMC10A115SET
- QAAMC10A115SM
- QAAMC10A115SN
- QAAMC10A115SO
- QAAMC10A115ST



<b>Locking Style</b>	Double Concentric
----------------------	-------------------

<b>Housing Construction</b>	Cartridge
-----------------------------	-----------

<b>UPC Code</b>	0883450023603
	0883450023610
	0883450023634
	0883450023641
	0883450023658
	0883450023665
	0883450023672
	0883450023689
	0883450194815
	0883450194983
	0883450271981
	0883450272155

## Dimensions

<b>Dimension A</b>	0.53 in 13.5 mm
--------------------	--------------------

<b>Dimension B</b>	0.91 in 23.1 mm
--------------------	--------------------

<b>Dimension C</b>	2.88 in 73.2 mm
--------------------	--------------------

<b>Dimension D</b>	0.19 in 4.8 mm
--------------------	-------------------

<b>Dimension F</b>	4.1250 in 104.8 mm
--------------------	-----------------------

<b>Dimension G</b>	2.45 in 62.2 mm
--------------------	--------------------

<b>Dimension L Exp</b>	3.2 in 81.3 mm
------------------------	-------------------

<b>Dimension L Fix</b>	3.12 in 79.2 mm
------------------------	--------------------

<b>Dimension M</b>	1.87 in 47.5 mm
--------------------	--------------------

<b>Dimension RAA</b>	0.66 in 16.8 mm
----------------------	--------------------

<b>Dimension SAA</b>	3.75 in 95.3 mm
----------------------	--------------------

## Radial and Thrust Factors

<b>C0 - Static Load</b>	26600 lbf 118000 N
-------------------------	-----------------------

<b>C - Dynamic Load (Basic)</b>	26300 lbf 117000 N
---------------------------------	-----------------------

<b>e - Geometry Factor</b>	0.24
----------------------------	------

<b>Y1 - Geometry Factor</b>	2.84
-----------------------------	------

<b>Y2 - Geometry Factor</b>	4.23
-----------------------------	------

## Engineering Seal Speed

<b>Oil Lubrication - M/N Seal</b>	2400 rpm
-----------------------------------	----------

<b>Oil Lubrication - T Seal</b>	4200 rpm
---------------------------------	----------

<b>Oil Lubrication - B/C/O Seal</b>	1800 rpm
-------------------------------------	----------

<b>Grease Lubrication - M/N Seal</b>	2400 rpm
--------------------------------------	----------

<b>Grease Lubrication - T Seal</b>	3550 rpm
------------------------------------	----------

<b>Grease Lubrication - B/C/O Seal</b>	1800 rpm
--	----------

## Engineering Bearing Attributes

<b>Float</b>	0.050 in 1.270 mm
--------------	----------------------

<b>Shaft Tolerance</b>	0.0015 in 0.038 mm
------------------------	-----------------------

## Engineering Internal Radial Clearance

<b>Eng Internal Radial Clearance - Min</b>	0.0014
--	--------

<b>Eng Internal Radial Clearance - Max</b>	0.0022
--	--------

<b>Pre Install Clearance Min</b>	0.0016 in 0.040 mm
----------------------------------	-----------------------

<b>Pre Install Clearance Max</b>	0.0026 in 0.065 mm
----------------------------------	-----------------------

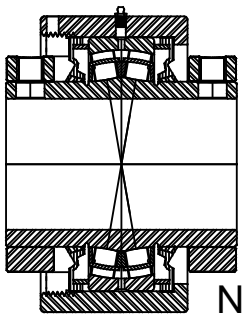
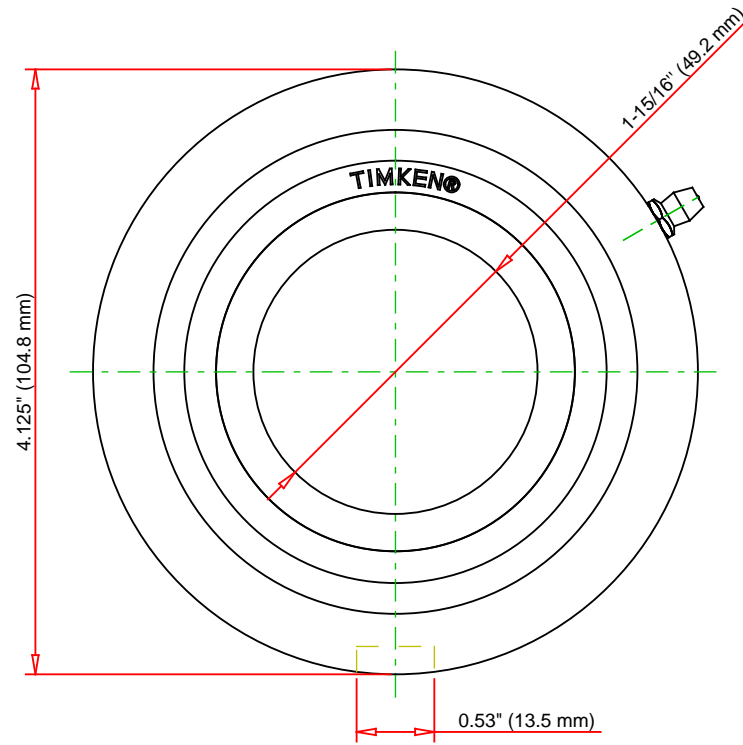
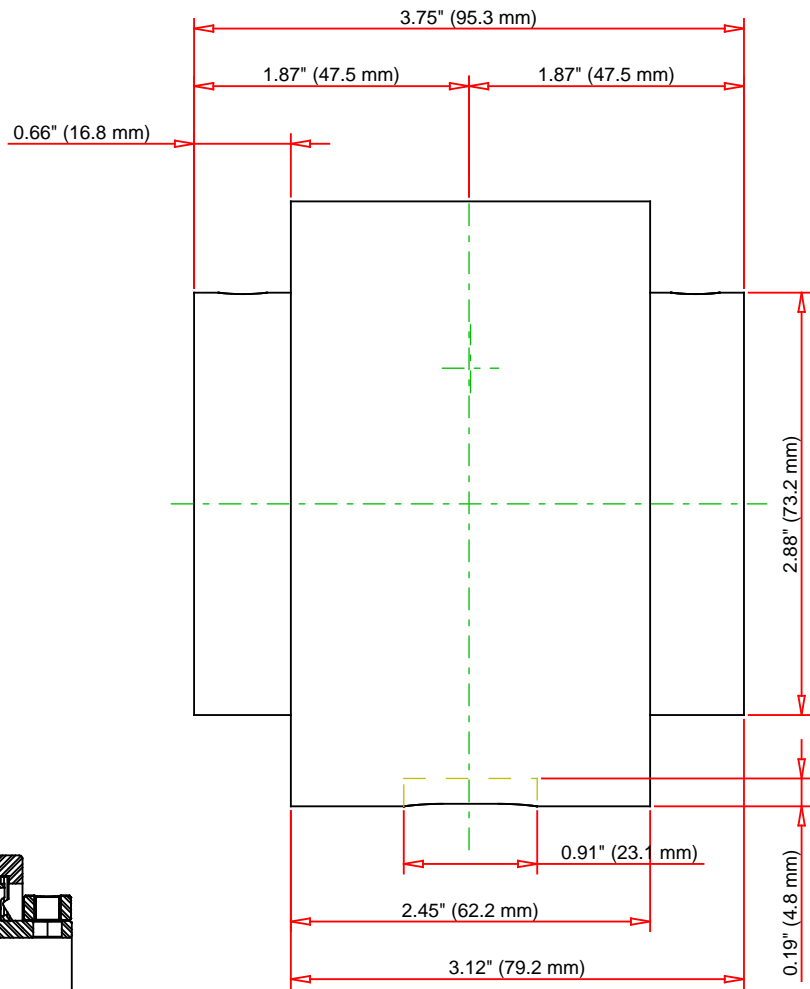

Note: Section View not to Scale

C - Dynamic Load	26300	lbf	117000	N
C0 - Static Load	26600	lbf	118000	N
Weight	8	lb	3.6	kg
Max. Speed T-Seals & Grease	3550	rpm		
Rad. Clearance - Max.	0.0022			

**TIMKEN**

THE TIMKEN COMPANY  
NORTH CANTON, OHIO USA

**QAAMC10A115S**  
Double Concentric Cartridge Block

Every reasonable effort has been made to ensure the accuracy of the information contained in this writing, but no liability is accepted for errors, omissions or for any other reason.

**FOR DISCUSSION ONLY**