

SHEET REV 52A107625 9	THIRD ANGLE PROJECTION	REVISIONS			
		REV.	DESCRIPTION	DATE	APPROVED
		9	ADDED PART #7 PER DS05-1253	11/10/05	RAJKUMAR

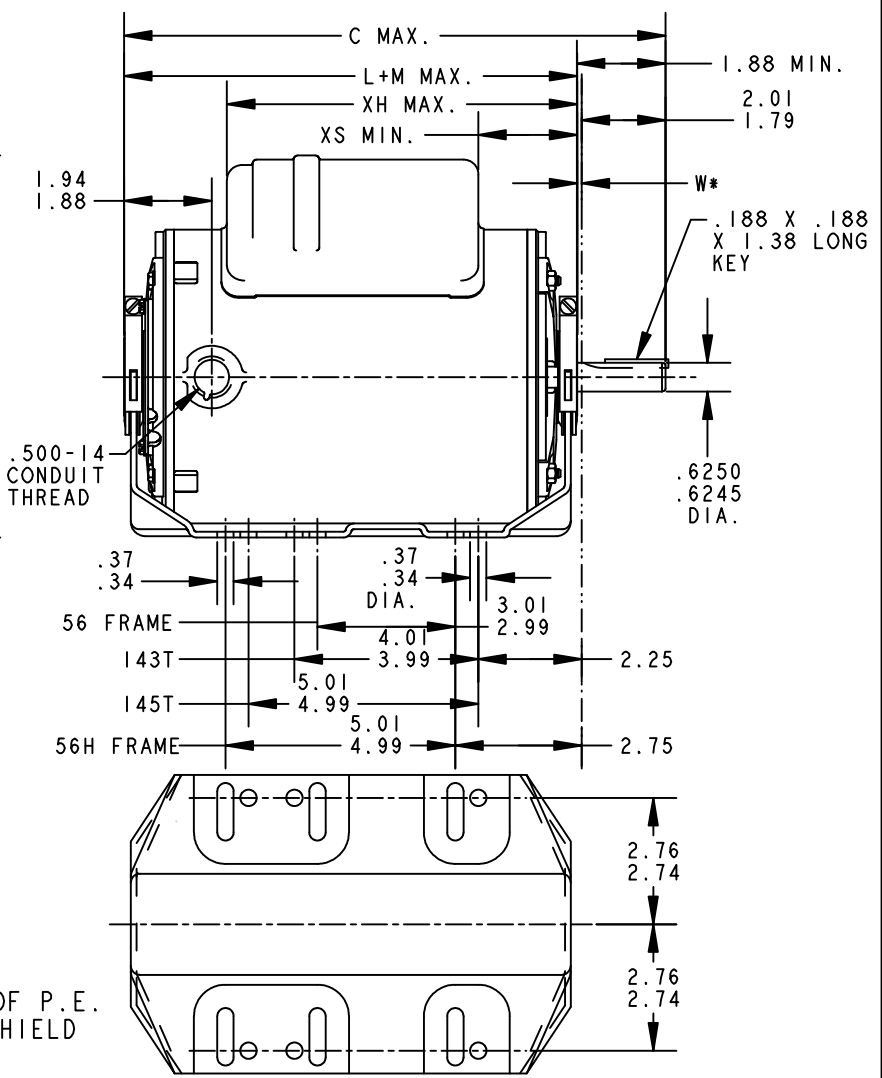
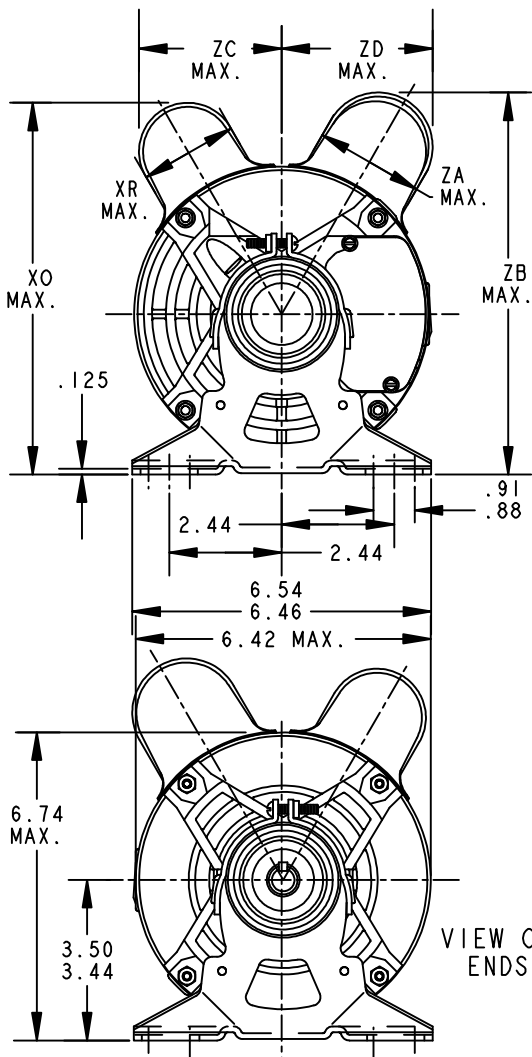

VIEW OF P.E. ENDSHIELD

W* IS A VARIABLE CLEARANCE DUE TO VARIATIONS IN PARTS AND ASSEMBLY.

7	KCR	49	56H	13.96	11.96	10.15	8.18	2.15	2.01	1.60	7.63	3.20	3.16	9.63
6	KCR	49	56H	13.96	11.96	8.30	8.16	2.10	2.63	2.40	8.39	3.14	3.33	9.63
5	KCR	49	56H	13.96	11.96	9.67	8.16	2.10	4.00	2.40	8.39	3.14	3.33	9.63
4	KCR	48	56H	12.66	10.76	7.76	8.18	2.15	2.01	2.40	8.40	3.20	3.38	8.43
3	KCR	48	56H	12.66	10.76	7.76	8.18	2.15	2.01	2.72	8.77	3.20	3.68	8.43
2	KCR	49	56H	11.91	10.01	7.76	8.18	2.15	2.01	1.60	7.81	3.20	2.86	7.68
1	KCR	49	56H	11.91	10.01	7.76	8.18	2.15	2.01	2.40	8.40	3.20	3.38	7.68
P	TYPE	GE SIZE	NEMA FR	C	L+M	XH	XO	XR	XS	ZA	ZB	ZC	ZD	MIN. SHELL

FOR ADDITIONAL INFO REFER TO: APPLIED PRACTICES DIMENSIONS ARE IN INCHES	SIGNATURES	DATE		REGAL-BELOIT CORPORATION		
	MODEL	M.D. PAPE			10/05/90	
	DETAIL	.	TITLE	OUTLINE		
	CHECKED	.				
	ENGRG	.	FMF: 40 FR. REDESIGN- GENERAL PURPOSE MOTOR- DRIP PROOF- BALL BEARING- RESILIENT BASE	SIZE DRAWING		
	MFG	.				
	QUALITY	.	52A107625	REV 9		
	ISSUED	B.L.J			06/10/93	
MATERIAL	SOLID MODEL: 52A107625			SCALE: 0.250	REF. No: .	SHEET 1 of 1