



---

# Customer information packet

## XL050762

.75HP, 1165RPM, 1PH, 60HZ, 56, 3540L, XPFC, F1

Class - CLI GP D; CLII GP F,G

Division - Division I

## Specifications

Enclosure	XPFC
Frame	56
Frame Material	Steel
Frequency	60.00 Hz
Haz Area Class and Group	CLI GP D; CLII GP F,G
Haz Area Division	Division I
Motor Letter Type	Cap Start, Induction Run
Output @ Frequency	.750 HP @ 60 HZ
Phase	1
Synchronous Speed @ Frequency	1200 RPM @ 60 HZ
Voltage @ Frequency	115.0 V @ 60 HZ 230.0 V @ 60 HZ
Agency Approvals	UL CSA
Ambient Temperature	40 °C
Auxillary Box	No Auxillary Box
Auxillary Box Lead Termination	None
Base Indicator	Rigid
Bearing Grease Type	Polyrex EM (-20F +300F)
Blower	None
Current @ Voltage	10.500 A @ 115.0 V 5.250 A @ 230.0 V
Design Code	L
Drip Cover	No Drip Cover
Duty Rating	CONT
Efficiency @ 100% Load	72.0 %
Electrically Isolated Bearing	Not Electrically Isolated
Feedback Device	NO FEEDBACK
Front Shaft Indicator	None
Haz Area Temp Code	T3C
Heater Indicator	No Heater
High Voltage Full Load Amps	5.3 a

## Part detail

Revision	B
Type	AC
Mech. spec.	35E353
Base	
Status	PRD/A
Elec. spec.	35WGG517
Layout	35LYE353
Eff. date	07-24-2024
CD Diagram	CD0001
Poles	06
Leads	6#18
Proprietary	False
Created date	12-02-2022

<b>Insulation Class</b>	F
<b>Inverter Code</b>	Not Inverter
<b>KVA Code</b>	L
<b>Lifting Lugs</b>	No Lifting Lugs
<b>Locked Bearing Indicator</b>	No Locked Bearing
<b>Motor Lead Quantity/Wire Size</b>	6 @ 18 AWG
<b>Motor Lead Termination</b>	Flying Leads
<b>Motor Standards</b>	NEMA
<b>Motor Type</b>	X3540L
<b>Mounting Arrangement</b>	F1
<b>Number of Poles</b>	6
<b>Overall Length</b>	17.40 IN
<b>Power Factor</b>	63
<b>Product Family</b>	Hazardous Location Motor
<b>Pulley End Bearing Type</b>	Ball
<b>Pulley Face Code</b>	Standard
<b>Pulley Shaft Indicator</b>	Standard
<b>Rodent Screen</b>	None
<b>RoHS Status</b>	ROHS NON-COMPLIANT
<b>Service Factor</b>	1.15
<b>Shaft Diameter</b>	0.625 IN
<b>Shaft Ground Indicator</b>	No Shaft Grounding
<b>Shaft Rotation</b>	Reversible
<b>Shaft Slinger Indicator</b>	No Slinger
<b>Speed</b>	1165 rpm
<b>Speed Code</b>	Single Speed
<b>Starting Method</b>	Direct on line
<b>Thermal Device - Bearing</b>	None
<b>Thermal Device - Winding</b>	Normally Closed Thermostat
<b>Vibration Sensor Indicator</b>	No Vibration Sensor
<b>Winding Thermal 1</b>	None
<b>Winding Thermal 2</b>	None

**Nameplate**

NP1426XPSL					
<b>NO.</b>		<b>CC</b>			
<b>SER.</b>					
<b>SPEC.</b>	35E353G517				
<b>CAT.NO.</b>	XL050762				
<b>HP</b>	.75	<b>T. CODE</b>	T3C		
<b>VOLTS</b>	115/230				
<b>AMPS</b>	10.5/5.25				
<b>RPM</b>	1165				
<b>HZ</b>	60	<b>PH</b>	1	<b>CL</b>	F
<b>SER.F.</b>	1.15	<b>DES</b>	L	<b>CODE</b>	L
<b>RATING</b>	40C AMB-CONT				
<b>FRAME</b>	56	<b>NEMA-NOM-EFF</b>		72	
	<b>PF</b>	63			
<b>BLANK</b>	NEMA MG-1 PART 5, IP54				

**AC Induction Motor Performance Data**

Record # 96489

Typical performance - not guaranteed values

Winding: 35WGG517-R001		Type: 3540L		Enclosure: TEFC	
<b>Nameplate Data</b>			<b>115 V, 60 Hz: Low Voltage Connection</b>		
Rated Output (HP)	.75	Full Load Torque	3.37 LB-FT		
Volts	115/230	Start Configuration	direct on line		
Full Load Amps	10.5/5.25	Breakdown Torque	8.9 LB-FT		
R.P.M.	1165	Pull-up Torque	4.6 LB-FT		
Hz	60	Locked-rotor Torque	9.5 LB-FT		
NEMA Design Code	L	Starting Current	47.6 A		
Service Factor (S.F.)	1.15	No-load Current	8.23 A		
NEMA Nom. Eff.	72	Line-line Res. @ 25°C	0.749 Ω A Ph 3.72 Ω B Ph		
Rating - Duty	40C AMB-CONT	Temp. Rise @ Rated Load	74°C		
S.F. Amps	11.2/5.6	Temp. Rise @ S.F. Load	83°C		
		Locked-rotor Power Factor	83.2		
		Rotor inertia	0.29 lb-ft <sup>2</sup>		

**Load Characteristics 115 V, 60 Hz, 0.75 HP**

% of Rated Load	25	50	75	100	125	150	S.F.
Power Factor	29	42	54	63	69	74	67
Efficiency	49.9	64.9	71.2	73.8	74.5	73.9	74.2
Speed	1191	1184	1176	1168	1158	1147	1162
Line amperes	8.4	8.84	9.55	10.5	11.8	13.3	11.3

ABB Motors and Mechanical Inc.

WINDING # 35WGG517

Typical performance - not guaranteed values.

0.75 HP 1 PH 60 HZ 1165 RPM 115 V 3540L

TORQUES (LB-FT): PO=8.9 PU=4.6 LR=9.5 LRA=47.6

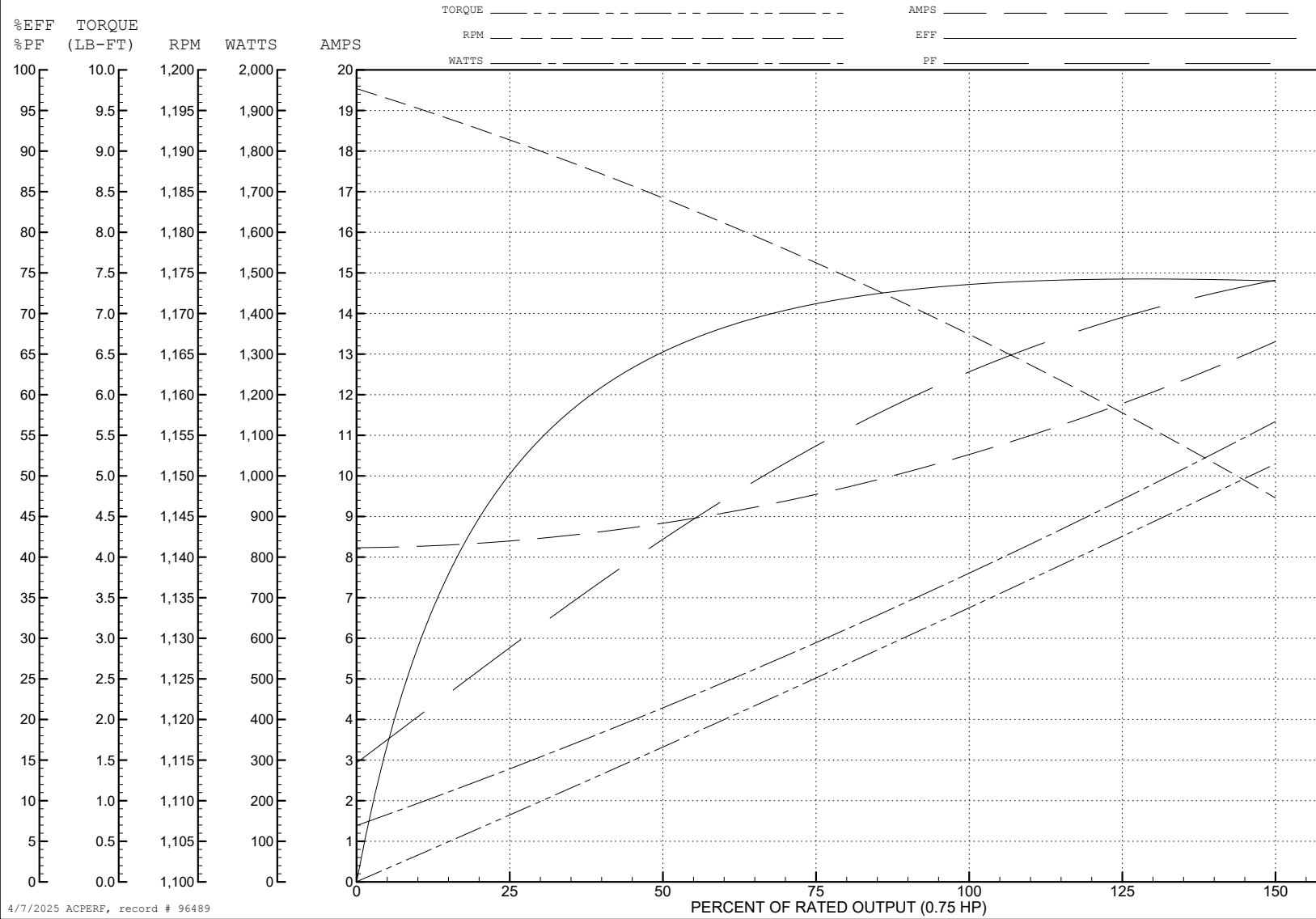

4/7/2025 ACPERF, record # 96489

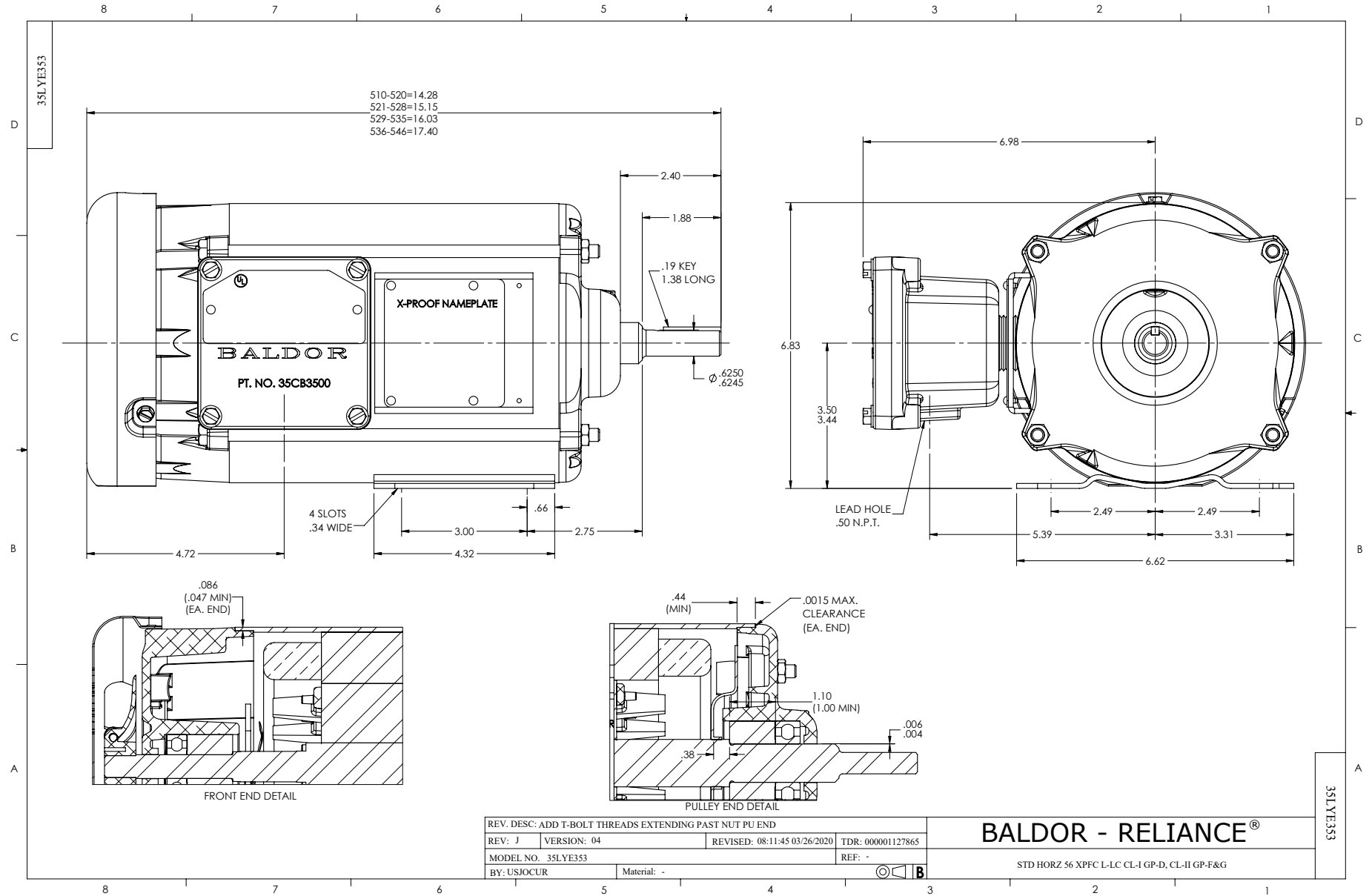

CD0001

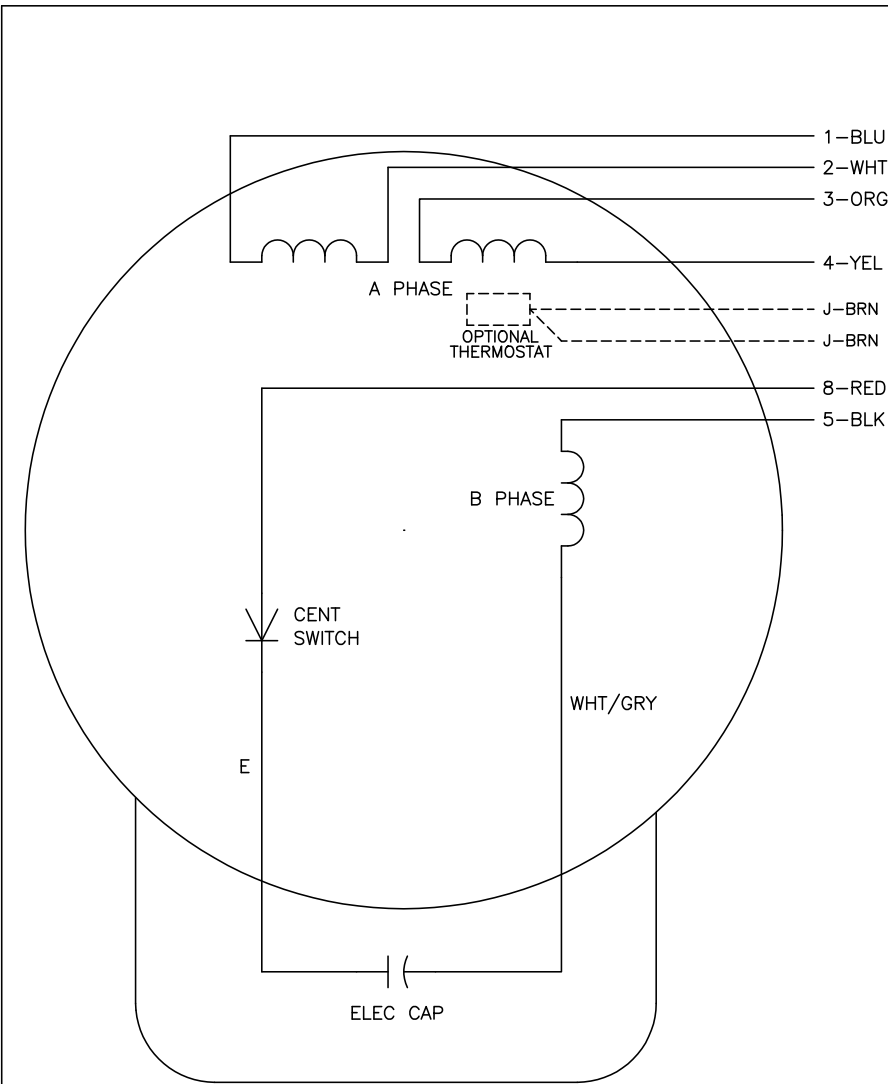

	LINE A	LINE B	JOIN
HIGH STD	1	4,5	2,3,8
HIGH OPP	1	4,8	2,3,5
LOW STD	1,3,8	2,4,5	-
LOW OPP	1,3,5	2,4,8	-

**NOTES:**

1. STANDARD ROTATION IS CCW FACING END OPPOSITE SHAFT EXTENSION.
2. OPTIONAL THERMOSTAT IS PROVIDED WHEN SPECIFIED.
3. MULTIPLE CAPACITORS ARE CONNECTED IN PARALLEL UNLESS OTHERWISE SPECIFIED.
4. LEAD COLORS ARE OPTIONAL. LEADS MUST ALWAYS BE NUMBERED AS SHOWN.

REV. DESC: REVISE TO SHOW OPTIONAL COLORS			
REV. LTR: D	BY: JLP	REVISED: 04/08/99 1:16	TDR: 0178636
100000		FILE: AAA00007405	MDL: -
		MTL: -	

**BALDOR ELECTRIC Co.**

TYPE L, DV, REV, 6 LEADS

CD0001