

RPM-AC FINNED FRAME VARIABLE SPEED ALTERNATING CURRENT MOTOR FL & UFL2586Z

ENCLOSURE: TOTALLY ENCLOSED
MOUNTING: FOOT
DRIVE METHOD: COUPLED OR BELTED

COOLING: BLOWER COOLED or FAN COOLED
ACCESSORIES: PROVISIONS FOR TACHOMETER MOUNTING ONLY WHEN SPECIFIED

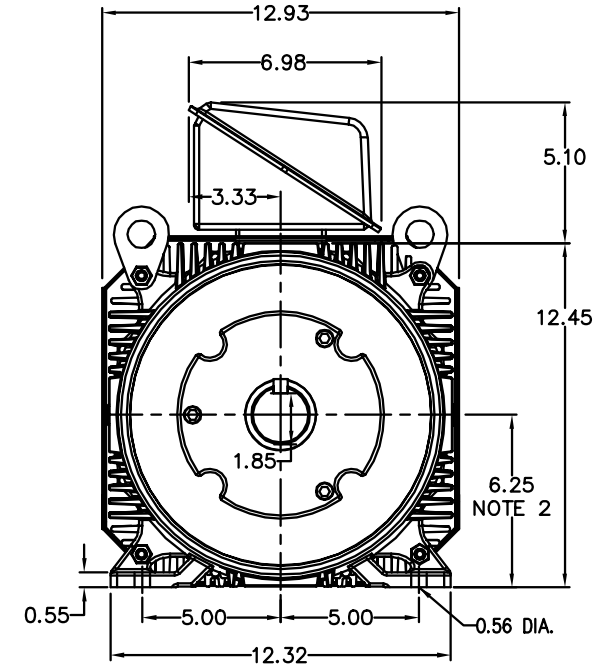
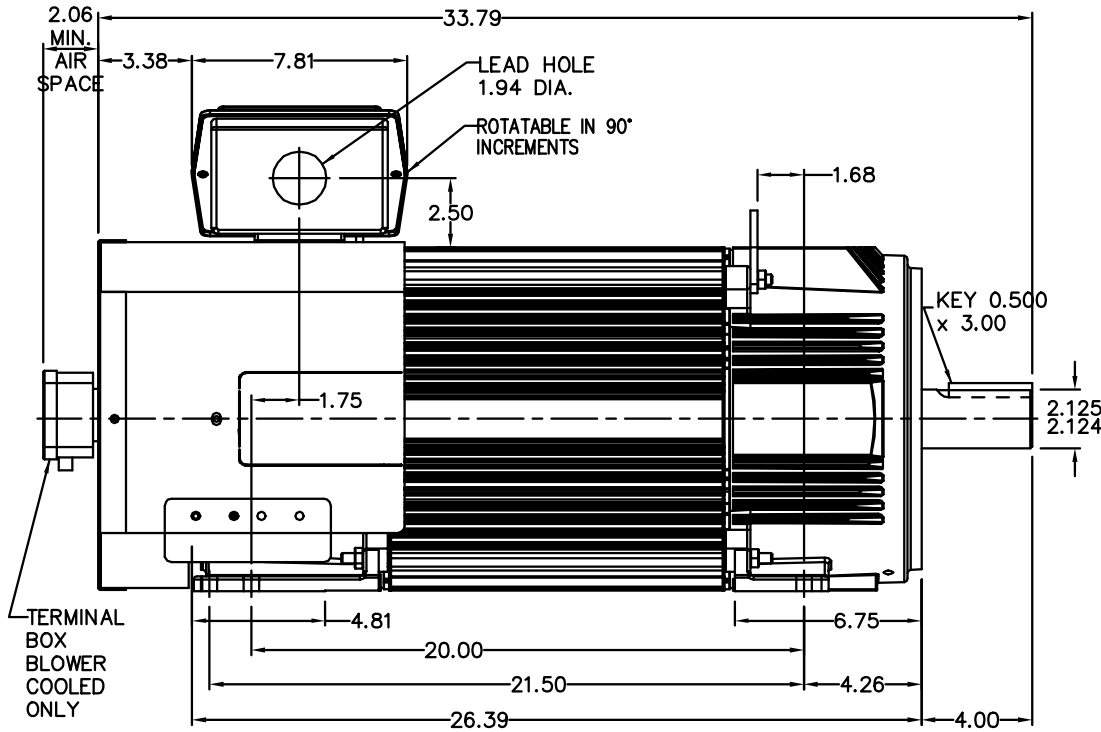

NOTE 1: C-FACE & TACHOMETER MOUNTING
1/2-13 TAP, 1.00 DEEP, ON A 7.25 DIA. BOLT CIRCLE
FACE RUNOUT AND ECCENTRICITY 0.004 MAX. T.I.R.

NOTE 2: SHAFT HEIGHT WILL NOT BE EXCEEDED
SHIMS UP TO 0.03 INCHES IN THICKNESS ARE USUALLY
REQUIRED FOR COUPLED OR GREARED MACHINES

TERMINAL BOX MAY BE LOCATED F1 OR F2 IF SPECIFIED
121 AMP STEEL TERMINAL BOX SHOWN
REFER TO 616779-50 FOR SPECIFIED TERMINAL BOX DIMENSIONS
REFER TO 616779-55 FOR SPECIFIED TACHOMETER DIMENSIONS

MOTOR WEIGHT: 605 LBS. (MAY VARY 15%)
DIMENSIONS ARE IN INCHES SCALE: 1.00

CUSTOMER IS RESPONSIBLE FOR DETERMINING THAT BALDOR'S PRODUCT WILL PERFORM SUITABLY IN THE INTENDED APPLICATION.

REV. DESC: ASSIGNED TO BUSLOAD	VERSION: 00	TDR: 000000475986
REV. LTR: -	REVISED: 15:23:16 09/17/2008	BY: CONBAT
FILE: \RGG\00002\904		
MTL: -		

BALDOR • DODGE • RELIANCE

DIM SHT FL & UFL2586Z RPM AC TE BLWR OR FAN COOLED

SH 1 of 1