

# RPM-AC FINNED FRAME VARIABLE SPEED ALTERNATING CURRENT MOTOR FL1852CZ

ENCLOSURE: TOTALLY ENCLOSED  
MOUNTING: FOOT / NEMA 250TC C-FACE  
DRIVE METHOD: COUPLED OR BELTED

COOLING: BLOWER COOLED  
ACCESSORIES: ENCODER

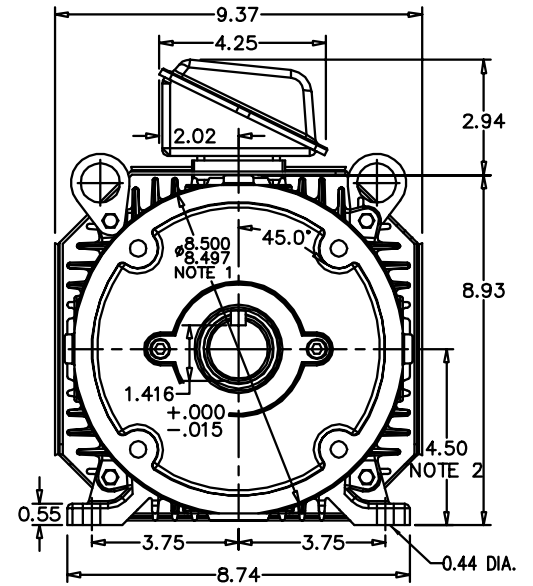
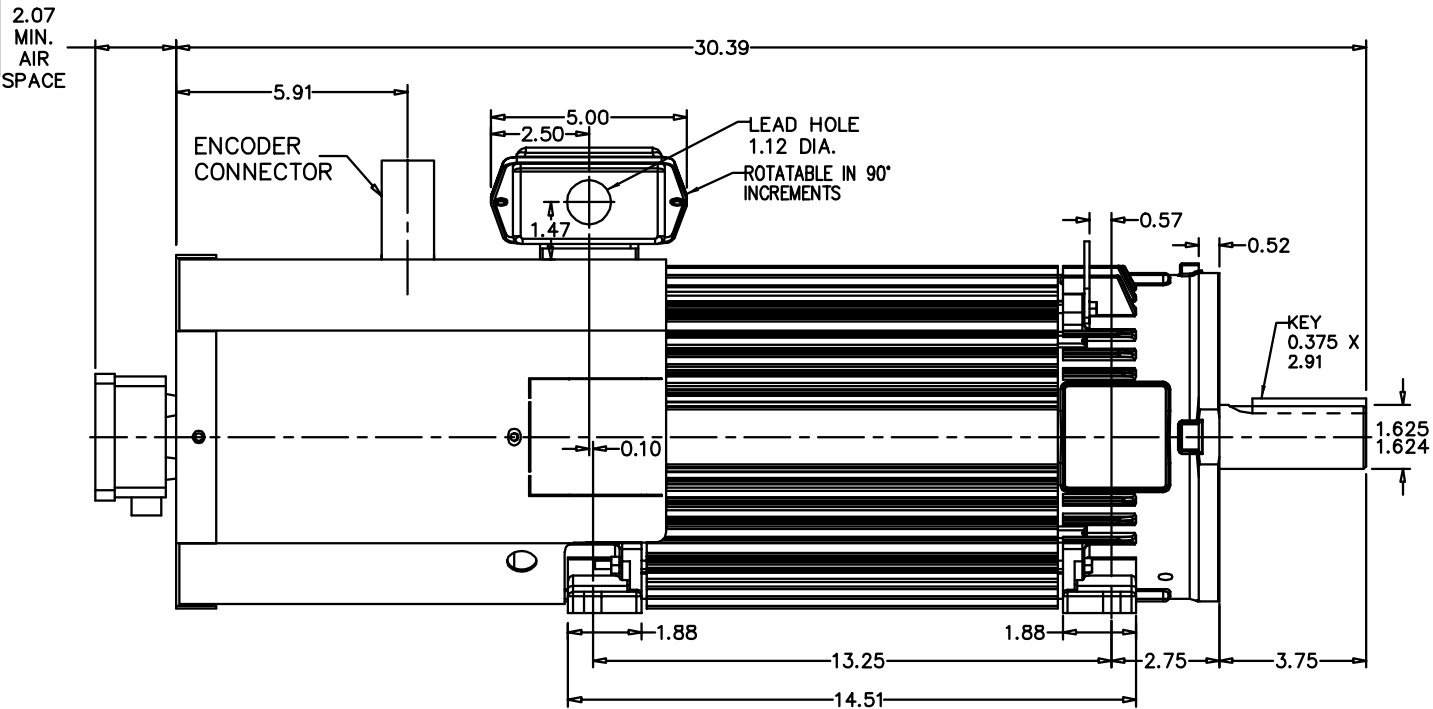

NOTE 1: C-FACE & TACHOMETER MOUNTING  
1/2-13 TAP, 1.00 DEEP, ON A 7.25 DIA. BOLT CIRCLE

NOTE 2: FACE RUNOUT AND ECCENTRICITY 0.004 MAX. T.I.R.  
SHAFT HEIGHT WILL NOT BE EXCEEDED  
SHIMS UP TO 0.03 INCHES IN THICKNESS ARE USUALLY  
REQUIRED FOR COUPLED OR GREARED MACHINES

TERMINAL BOX MAY BE LOCATED F1 OR F2 IF SPECIFIED  
40 AMP STEEL TERMINAL BOX SHOWN  
REFER TO 616779-50 FOR SPECIFIED TERMINAL BOX DIMENSIONS

MOTOR WEIGHT: 209 LBS. (MAY VARY 15%)  
DIMENSIONS ARE IN INCHES SCALE: 1.00

CUSTOMER IS RESPONSIBLE FOR DETERMINING THAT THIS PRODUCT WILL PERFORM SUITABLY IN THE INTENDED APPLICATION.

REV. DESC: CHANGE TO GENERIC CONNECTOR AND ENCODER		
REV. LTR: C	VERSION: 03	TDR: 00000984829
FILE: \RGG\00025\785	REVISED: 09:39:14 06/27/2016	BY: RGGWT
MTL: -		

**BALDOR**

DIM SHT,RPMAC,TEBC,FL1852CZ,250TC,ENCODER

SH 1 of 1