

DESCRIPTION

These regulators are designed to prevent erratic operation of pneumatic equipment with high capacity requirements by converting variable inlet pressures from source, into constant regulated feed pressures, adjustable up to 125 psi.

Both Models are "Relieving type" regulators with a design feature that automatically bleeds off back pressure when the unit is adjusted to a lower pressure setting.

A balanced disc, plus large orifices and flow ports provide exceptional performance with minimal pressure drop.

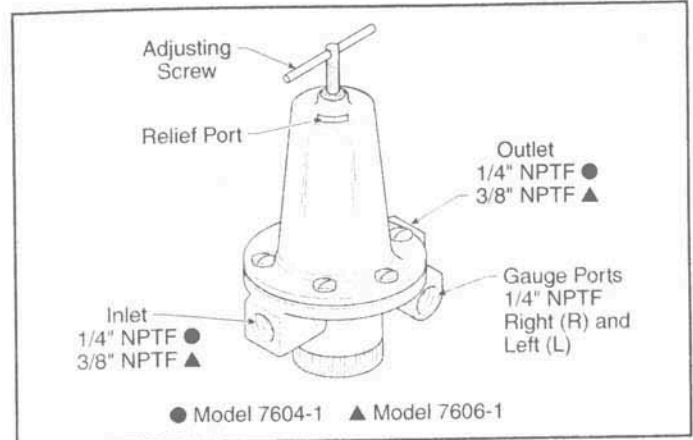
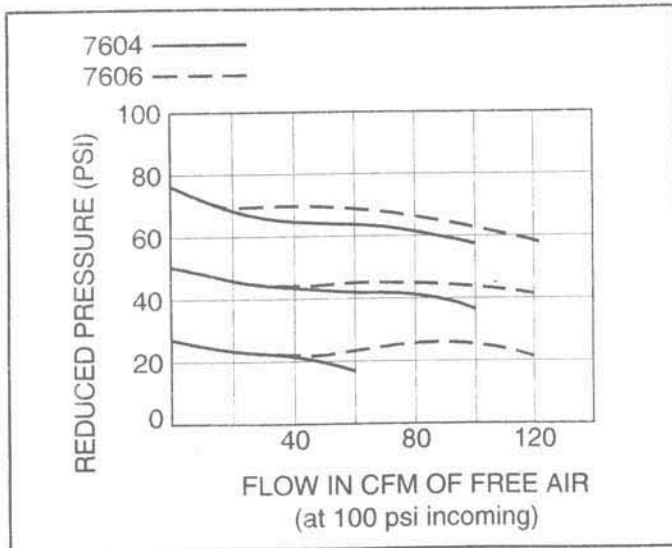

Figure 1: Air Regulators

SPECIFICATIONS

Maximum Air Pressure	300 psi
Regulated Discharge Pressure	0 to 125 psi
Operating Temperature Range	0 to 120°F
Weight	1.8 lbs.



PERFORMANCE CHART

INSTALLATION

CAUTION: Relieve system pressures before installing.

Observe the following notes in regard to installation.

1. Before installing regulator, blow out the pipe line to remove scale and other foreign matter.
2. Air line filters should be used in conjunction with these regulators to ensure trouble free performance.
3. Make thread connections using a pipe compound sparingly on male threads only.
4. Choose an installation site as close as possible to the equipment to be served.
5. Install regulator in pipe line so air will flow IN to OUT as indicated (by arrows) on housing of regulator. Make sure regulator is downstream from filter (if present) and upstream of any line lubrication devices.
6. Gauge ports "R" and "L" are normally for gauge use, but may be used for outlet purposes. Make sure to close any unused port with supplied plug(s).

CAUTION: If the regulator is installed incorrectly, reverse air flow will result, causing the unregulated air to escape rapidly out of the relief port when the air pressure is turned on. This can create the impression that the diaphragm of the regulator has failed.

FOR FURTHER SERVICE, CONTACT YOUR LOCAL ALEMITE DISTRIBUTION CENTER



ALEMITE, LLC
167 ROWELAND DR.
JOHNSON CITY, TN 37601

www.Alemite.com 1.866.4.Alemite (US) 1.803.802.0155 (International)

OPERATION AND ADJUSTMENT

IMPORTANT: Before putting regulator into operation, make sure all connections are secure.

1. Turn adjusting screw counterclockwise until there is no back pressure from spring

NOTE: This point of adjustment should register "0" on a pressure gauge after air line is opened.

2. With source pressure on, turn adjusting screw clockwise until desired regulated pressure is reached. Lock nut should be set to prevent accidental movement of adjustment screw. Further adjustments may be made at any time by lowering the height of the adjustment screw to increase pressure, and raising it to reduce pressure.

MAINTENANCE

If air supply is kept clean, the regulator should provide long periods of uninterrupted service. Erratic regulator operation or loss of regulating capabilities is most often the result of dirt in valve assembly. Carefully refer to DISASSEMBLY procedure, WARNINGS and CAUTIONS before undertaking any maintenance.

NOTE: Steps 1, 3, 4, 9 and 10A in DISASSEMBLY procedure comprise routine cleaning procedure.

Periodically lubricate adjusting screw with SAE 90 gear oil.

DISASSEMBLY

CAUTION: Never attempt any maintenance or repairs on regulator while it is under pressure.

NOTE: Removal of regulator from air line is not imperative as long as it is easily accessible.

1. Shut off air supply and relieve any residual pressure in regulator.
2. Remove adjusting screw and lock nut at top of regulator.
3. Loosen and slowly remove bottom plug.

CAUTION: Bottom plug is spring loaded.

4. Remove spring and Inner Valve assembly from cavity.
 - (A) Wipe off valve seat.
 - (B) Blow out body cavity with compressed air.

NOTE: Make sure Inner Valve is in center hole of body at reassembly.

5. Remove "O" Ring from bottom plug.

NOTE: Lightly grease "O" Ring at reassembly.

6. Remove valve seat from cavity.

CAUTION: Using inappropriate tools to remove valve seat may damage fitting.

IMPORTANT: Before reassembly, clean threads of valve seat and valve seat cavity thoroughly and apply Loctite Locquic Grade "T" Primer. After it dries, sparingly apply Loctite No. 69 to male threads only.

7. Remove six screws at base of bonnet assembly and lift it from body assembly.

NOTE: At reassembly, tighten six screws according to pattern shown below and make sure diaphragm is firmly compressed between bonnet and body assemblies.

8. Remove spring pad, spring and diaphragm assembly from body assembly.

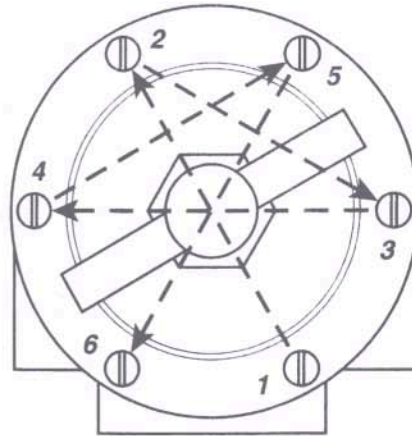

NOTE: Make sure concave side of spring pad is face up at reassembly.

9. Clean all disassembled parts with denatured alcohol and check for wear or damage.

CAUTION: Damaged or worn parts may threaten personal safety and/or impair reliability of unit. Never reuse them.

- 10.(A) For routine cleaning procedure, reassemble by reversing steps 1, 3 and 4.
 - (B) For complete Disassembly procedure, reassemble by reversing steps 1 through 8.

Kit Contents

● **39339-74 For Both Models**

- Adjusting Screw
- Lock Nut

▲ **39339-76 For Both Models**

- Diaphragm Assembly
- Inner Valve Assembly
- "O" Ring

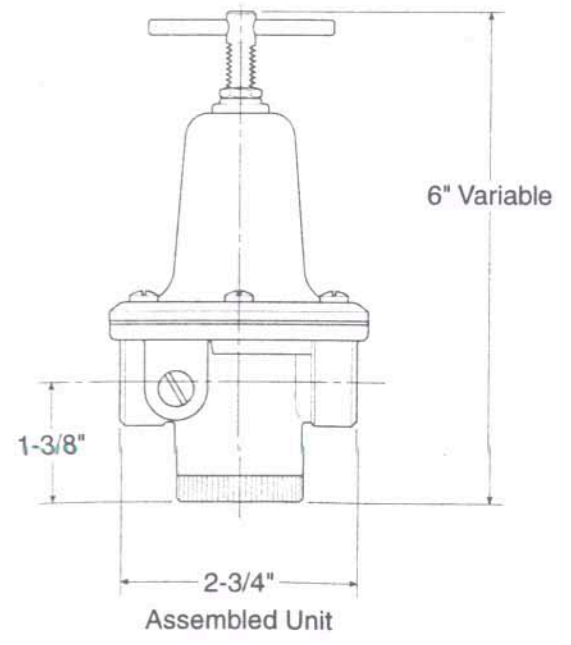
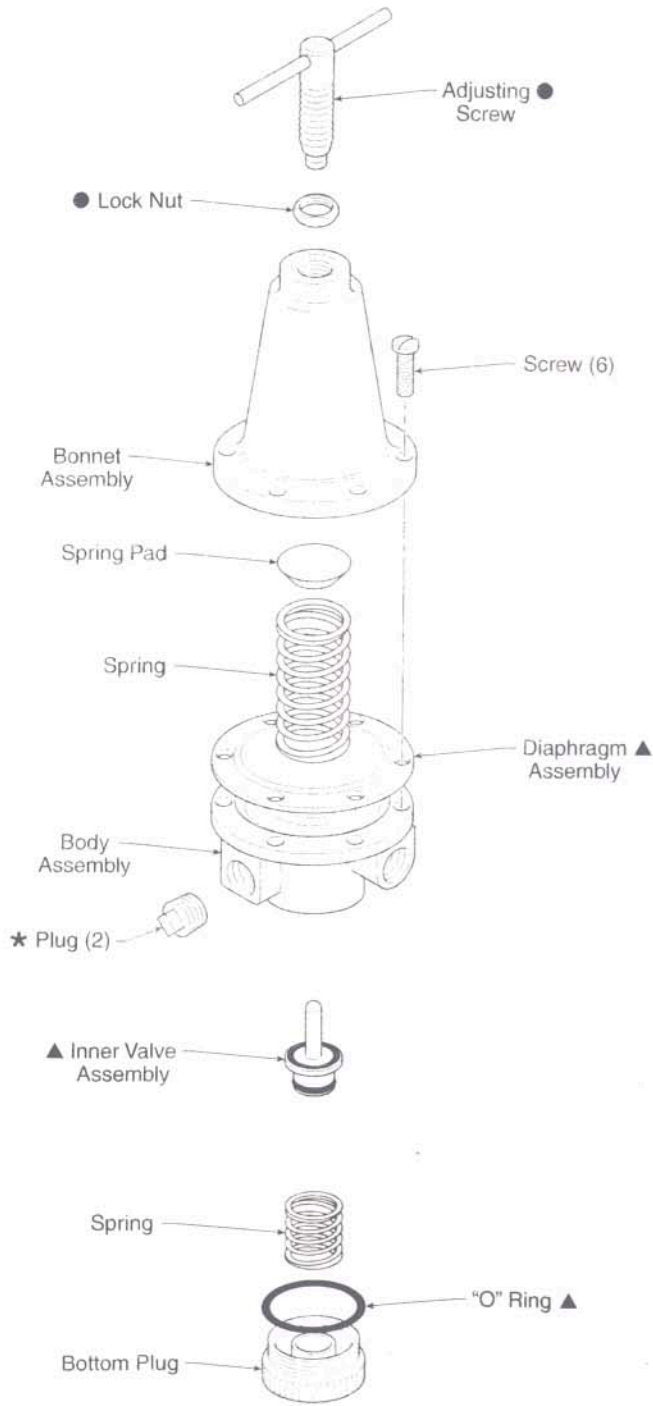

- Comprises Kit 39339-74
- ▲ Comprises Kit 39339-76
- ★ Shipped Loose

Figure 2: Models 7604-1 and 7606-1 Air Regulators

WARNING

To avoid unpredictable system behavior that can cause personal injury and property damage:

- Disconnect electrical supply (when necessary) before installation, servicing, or conversion.
- Disconnect air supply and depressurize all air lines connected to this product before installation, servicing, or conversion.
- Operate within the manufacturer's specified pressure, temperature, and other conditions listed in these instructions.
- Medium must be moisture-free if ambient temperature is below freezing.
- Service according to procedures listed in these instructions.
- Installation, service, and conversion of these products must be performed by knowledgeable personnel who understand how pneumatic products are to be applied.
- After installation, servicing, or conversion, air and electrical supplies (when necessary) should be connected and the product tested for proper function and leakage. If audible leakage is present, or the product does not operate properly, do not put into use.
- Warnings and specifications on the product should not be covered by paint, etc. If masking is not possible, contact your local representative for replacement labels.

WARNING

Product rupture can cause serious injury.

Do not connect regulator to bottled gas.

Do not exceed maximum primary pressure rating.

WARNING

FAILURE OR IMPROPER SELECTION OR IMPROPER USE OF THE PRODUCTS AND/OR SYSTEMS DESCRIBED HEREIN OR RELATED ITEMS CAN CAUSE DEATH, PERSONAL INJURY AND PROPERTY DAMAGE.

This document and other information from The Company, its subsidiaries and authorized distributors provide product and/or system options for further investigation by users having technical expertise. It is important that you analyze all aspects of your application, including consequences of any failure and review the information concerning the product or systems in the current product catalog. Due to the variety of operating conditions and applications for these products or systems, the user, through its own analysis and testing, is solely responsible for making the final selection of the products and systems and assuring that all performance, safety and warning requirements of the application are met.

The products described herein, including without limitation, product features, specifications, designs, availability and pricing, are subject to change by The Company and its subsidiaries at any time without notice.

EXTRA COPIES OF THESE INSTRUCTIONS ARE AVAILABLE FOR INCLUSION IN EQUIPMENT / MAINTENANCE MANUALS THAT UTILIZE THESE PRODUCTS. CONTACT YOUR LOCAL REPRESENTATIVE.