

The right choice for the ultimate yield!

LS ELECTRIC strives to maximize your profits in gratitude for choosing us as your partner.

## Programmable Logic Control

# XGT Ethernet Module

**XGT Series**

**User Manual**

**XGL-EFMTB**  
**XGL-EFMFB**  
**XGL-EFMHB**  
**XOL-ES4T**  
**XOL-ES4H**  
**XGL-EH5T**  
**XGL-EFMT**  
**XGL-EFMF**



### Safety Instructions

- Read this manual carefully before installing, wiring, operating, servicing or inspecting this equipment.
- Keep this manual within easy reach for quick reference.

**LS**<sup>→</sup>**ELECTRIC**

### Before using the product ...

For your safety and effective operation, please read the safety instructions thoroughly before using the product. Safety Instructions should always be observed in order to prevent accident or risk with the safe and proper use the product.

Instructions are divided into “Warning” and “Caution”, and the meaning of the terms is as follows.

 **Warning** This symbol indicates the possibility of serious injury or death if some applicable instruction is violated

 **Caution** This symbol indicates the possibility of severe or slight injury, and property damages if some applicable instruction is violated

Moreover, even classified events under its  caution category may develop into serious accidents relying on situations. Therefore we strongly advise users to observe all precautions properly just like warnings.

The marks displayed on the product and in the user’s manual have the following meanings.

 Be careful! Danger may be expected.

 Be careful! Electric shock may occur.

The user’s manual even after read shall be kept available and accessible to any user of the product.

## Safety Instructions for design process

### Warning

1. **Please install a protection circuit on the exterior of PLC so that the whole system may operate safely regardless of failures from external power or PLC.** Any abnormal output or operation from PLC may cause serious problems to safety in whole system.
  - Install protection units on the exterior of PLC like an interlock circuit that deals with opposite operations such as emergency stop, protection circuit, and forward/reverse rotation or install an interlock circuit that deals with high/low limit under its position controls.
  - If any system error (watch-dog timer error, module installation error, etc.) is detected during CPU operation in PLC, all output signals are designed to be turned off and stopped for safety. However, there are cases when output signals remain active due to device failures in Relay and TR which can't be detected. Thus, you are recommended to install an addition circuit to monitor the output status for those critical outputs which may cause significant problems.
2. **Never overload more than rated current of output module nor allow to have a short circuit.** Over current for a long period time may cause a fire .
3. **Never let the external power of the output circuit to be on earlier than PLC power,** which may cause accidents from abnormal output or operation.
4. **Please install interlock circuits in the sequence program for safe operations in the system when exchange data with PLC or modify operation modes using a computer or other external equipments** Read specific instructions thoroughly when conducting control operations with PLC.

## Safety Instructions for design process

### **Caution**

I/O signal or communication line shall be wired at least 100mm away from a high-voltage cable or power line. Fail to follow this instruction may cause malfunctions from noise

## Safety Instructions on installation process

### **Caution**

1. **Use PLC only in the environment specified in PLC manual or general standard of data sheet.** If not, electric shock, fire, abnormal operation of the product may be caused.
2. **Before install or remove the module, be sure PLC power is off.** If not, electric shock or damage on the product may be caused.
3. **Be sure that every module is securely attached after adding a module or an extension connector.** If the product is installed loosely or incorrectly, abnormal operation, error or dropping may be caused. In addition, contact failures under poor cable installation will be causing malfunctions as well.
4. **Be sure that screws get tighten securely under vibrating environments.** Fail to do so will put the product under direct vibrations which will cause electric shock, fire and abnormal operation.
5. **Do not come in contact with conducting parts in each module,** which may cause electric shock, malfunctions or abnormal operation.

## Safety Instructions for wiring process

### **Warning**

1. **Prior to wiring works, make sure that every power is turned off.** If not, electric shock or damage on the product may be caused.
2. **After wiring process is done, make sure that terminal covers are installed properly before its use.** Fail to install the cover may cause electric shocks.

### **Caution**

1. **Check rated voltages and terminal arrangements in each product prior to its wiring process.** Applying incorrect voltages other than rated voltages and misarrangement among terminals may cause fire or malfunctions.
2. **Secure terminal screws tightly applying with specified torque.** If the screws get loose, short circuit, fire or abnormal operation may be caused. Securing screws too tightly will cause damages to the module or malfunctions, short circuit, and dropping.
3. **Be sure to earth to the ground using Class 3 wires for FG terminals which is exclusively used for PLC.** If the terminals not grounded correctly, abnormal operation or electric shock may be caused.
4. **Don't let any foreign materials such as wiring waste inside the module while wiring,** which may cause fire, damage on the product or abnormal operation.
5. **Make sure that pressed terminals get tighten following the specified torque. External connector type shall be pressed or soldered using proper equipments.**

## Safety Instructions for test-operation and maintenance

### **Warning**

1. **Don't touch the terminal when powered.** Electric shock or abnormal operation may occur.
2. **Prior to cleaning or tightening the terminal screws, let all the external power off including PLC power.** If not, electric shock or abnormal operation may occur.
3. **Don't let the battery recharged, disassembled, heated, short or soldered.** Heat, explosion or ignition may cause injuries or fire.

### **Caution**

1. **Do not make modifications or disassemble each module.** Fire, electric shock or abnormal operation may occur.
2. **Prior to installing or disassembling the module, let all the external power off including PLC power.** If not, electric shock or abnormal operation may occur.
3. **Keep any wireless equipment such as walkie-talkie or cell phones at least 30cm away from PLC.** If not, abnormal operation may be caused.
4. **When making a modification on programs or using run to modify functions under PLC operations, read and comprehend all contents in the manual fully.** Mismanagement will cause damages to products and accidents.
5. **Avoid any physical impact to the battery and prevent it from dropping as well.** Damages to battery may cause leakage from its fluid. When battery was dropped or exposed under strong impact, never reuse the battery again. Moreover skilled workers are needed when exchanging batteries.

## Safety Instructions for waste disposal

 **Caution**

- ▶ **Product or battery waste shall be processed as industrial waste.** The waste may discharge toxic materials or explode itself.

# Revision History

Version	Date	Remark	Page
V1.0	2005.03	First Edition	-
V1.1	2005.05	Adding the function description	-
V1.2	2005.09	Adding module detachment and how to change Setting PLC type at XG-PD Adding appendix (CPU memory device)	CH3.8 CH5.2 APPENDIX-
V1.3	2005.11	Fixing figure and adding contents	-
V1.4	2005.11	Fixing figure and contents	-
V1.5	2008.07	1. Adding models -adding XGI/XGR redundant system -adding switch module (XGL-EH5T) 2. Adding E-mail service 3. Adding error code table 4. Adding CH 11 Compliance with EMC Specifications 5. Fixing headquarter address	CH1.3.2 CH7.6 CH10.4 CH11 Back cover-
V1.6	2009.09	1. Modifying Overview 2. Adding CPU 3. Adding contents on standard setting (One IP Solution, DHCP)	CH1.2.1 CH1.3.2 CH5.3
V1.7	2011.05	1. How to enable link through flag added 2. Write_NC, Send_NC" instruction added	CH5.5.2 CH7.2.1
V1.8	2013.10	1. Adding Communication load specifications 2. Changing Modbus server offset area	CH2.2.3 CH8.3.1
V1.9	2014.03	1. Changing Communication load specifications 2. Adding info-U, iXP 3. Adding XGR HS Link 4. Adding XGT Dedicated Communication's Header 5. Adding XGT Dedicated Communication's error Code 6. Adding High Performance XGT 7. Changing error code table	CH2.2.3 CH4 CH6.6~6.7 CH8.1.2 CH8 CH9.2.3 CH10.4
V 2.0	2014.11	XG5000 V4.0 UI Update	-
V2.1	2016.10	XGL-EFMTB, XGL-EFMFB contents added	-
V2.2	2017.06	Adding RAPIEnet protocol and Cnet protocol	-
V2.21	2017.09	Error code update	CH10.2.2
V2.30	2018.05	Adding OPC UA Server service	CH12
V3.0	2020.02	Adding Smart extension service	-

Version	Date	Remark	Page
V3.1	2020.06	1. Format and contents modification according to the change of company name(LSIS -> LS ELECTRIC) 2. Adding RAPIEnet+ autoscan 3. Adding Smart Extension service diagnostic variables	ALL CH3.6 CH4, CH9
V3.2	2020.11	1. MRS IP assignment description added 2. Basic parameter description added	CH2.2, CH2.3 CH3.5
V3.3	2022.10	1. DLR topology added 2. Host table setting added 3. Server service user setting function added 4. Communication module object data send and receive function added 5. Error Frame Log added	CH2.2 CH3.5 CH7.5 CH8.4 CH9.2
V3.4	2022.11	1. XGI CPU flag list added 2. FEnet connection information list added	APPENDIX
V3.5	2024.01	DNP3 Server Added	CH7.6
V3.6	2024.06	1. Added input data clear function when high-speed link timeout occurs 2. Change warranty period	CH5 -
V3.61	2024.09	Error code update	CH9.2.2
V3.62	2024.11	Added version compatibility for using OPC UA server - Not available if HW version is V3.0 or higher	CH7.4

Thank you for purchasing PLC of LS ELECTRIC Co., Ltd.

Before use, make sure to carefully read and understand the User's Manual about the functions, performances, installation and programming of the product you purchased in order for correct use and importantly, let the end user and maintenance administrator to be provided with the User's Manual.

The User's Manual describes the product. If necessary, you may refer to the following description and order accordingly. In addition, you may connect our website (<http://www.ls-electric.com/>) and download the information as a PDF file.

### Relevant User's Manuals

Title	Description
XG5000 User's Manual (for XGK, XGB)	XG5000 software user manual describing online function such as programming, print, monitoring, debugging by using XGK, XGB CPU
XG5000 User's Manual (for XGI, XGR)	XG5000 software user manual describing online function such as programming, print, monitoring, debugging by using XGI, XGR CPU
XGK/XGB Instructions & Programming User's Manual	User's manual for programming to explain how to use instructions that are used PLC system with XGK, XGB CPU.
XGI/XGR Instructions & Programming User's Manual	User's manual for programming to explain how to use instructions that are used PLC system with XGI, XGR CPU.
XGK CPU User's Manual	XGK-CPUU/CPUH/CPUA/CPUS/CPUE/CPUSN/CPUHN/ CPUUN user manual describing about XGK CPU module, power module, base, IO module, specification of extension cable and system configuration, EMC standard
XGI CPU User's Manual	XGI-CPUU/D,CPUU,CPUH,CPUS,CPUE,CPUUN user manual describing about XGI CPU module, power module, base, IO module, specification of extension cable and system configuration, EMC standard
XGR redundant series User's Manual	XGR- CPUH/F, CPUH/T user manual describing about XGR CPU module, power module, extension drive, base, IO module, specification of extension cable and system configuration, EMC standard
Communication device User's Manual	User's manual for programming to explain how to use Extension driver, Smart I/O extension, Smart I/O block

# Contents

<b>CHAPTER 1 OVERVIEW.....</b>	<b>1-1</b>
1.1 GUIDE TO USE THIS MANUAL.....	1-1
1.2 CHARACTERISTICS.....	1-2
1.2.1 Ethernet module.....	1-2
1.2.2 Switch module.....	1-3
1.2.3 Product name.....	1-4
1.2.4 Function Items by Version.....	1-4
1.2.5 Number of units that can be installed for each CPU.....	1-7
1.3 SOFTWARE FOR USING THE PRODUCT.....	1-8
1.3.1 Software checklist.....	1-8
1.3.2 Checking the product information.....	1-10
<b>CHAPTER 2 PRODUCT SPECIFICATIONS.....</b>	<b>2-1</b>
2.1 GENERAL SPECIFICATIONS.....	2-1
2.2 PERFORMANCE SPECIFICATIONS.....	2-2
2.2.1 Ethernet module.....	2-3
2.2.2 Switch module.....	2-4
2.2.3 Power specification.....	2-5
2.2.4 Load specifications.....	2-5
2.3 STRUCTURE AND CHARACTERISTICS.....	2-7
2.3.1 Names of Part and Function.....	2-7
2.4 SPECIFICATION OF CABLE.....	2-16
2.4.1 Twisted pair cable.....	2-16
2.4.2 Optical Fiber Cable.....	2-17
2.5 HOW TO CONNECT COMMUNICATION BETWEEN OUR PRODUCTS.....	2-18
2.5.1 Master communication.....	2-18
2.5.2 Slave communication.....	2-19
<b>CHAPTER 3 PRODUCT INSTALLATION AND TRIAL OPERATION.....</b>	<b>3-1</b>
3.1 PRODUCT INSTALLATION.....	3-1
3.1.1 Preparation for operating.....	3-1
3.1.2 Setting sequence for operation.....	3-2
3.2 INSTALLATION.....	3-3
3.2.1 Ethernet module.....	3-3
3.2.2 Installing and Removing the Switch Module.....	3-5

3.3	TEST OPERATION.....	3-7
3.3.1	Precautions for System Configuration.....	3-7
3.3.2	Check items before trial operation.....	3-7
3.3.3	The method to remove and replace the module.....	3-9
3.4	PRECAUTIONS WHEN CONNECTING TO A NETWORK.....	3-10
3.4.1	Use ring network.....	3-10
3.4.2	Use line network.....	3-11
3.5	XG5000 PROGRAM.....	3-12
3.5.1	CPU type setting.....	3-12
3.5.2	Communication module registration.....	3-13
3.5.3	Basic settings.....	3-17
3.5.4	Security setting.....	3-23
3.5.5	Time synchronization Setting.....	3-25
3.5.6	EIP Target Setting.....	3-26
3.5.7	Advanced Settings.....	3-26
3.5.8	Download/Upload.....	3-27
3.5.9	Link enable.....	3-30
3.6	SYSTEM DIAGNOSIS.....	3-34
3.6.1	Diagnostics.....	3-34
3.6.2	Types of diagnostic functions.....	3-35
<b>CHAPTER 4</b>	<b>SMART EXTENSION SERVICE.....</b>	<b>4-1</b>
4.1	OVERVIEW.....	4-1
4.2	SMART EXTENSION SERVICE SETTING.....	4-2
4.2.1	Standard settings.....	4-2
4.2.2	Smart extension service.....	4-3
4.2.3	Smart Extension master setting.....	4-8
4.2.4	Communication device setting.....	4-20
4.2.5	Smart Extension service setting Download.....	4-23
4.2.6	Smart Extension Enable Services.....	4-24
4.3	HOT SWAPPING FUNCTION.....	4-25
4.3.1	Hot Swap Operation.....	4-25
4.3.2	Hot Swap Operation setting.....	4-26
4.3.3	Diagnostic Variable Operation According to Exchange EB or modules while running (hot swap) Option.....	4-27
4.3.4	Operation by Hot Swap Setting.....	4-29
4.3.5	Operation and Return Condition of Communication Device According to Hot Swap Setting.....	4-34
4.4	SMART EXTENSION SERVICE OPERATION.....	4-36
4.5	SMART EXTENSION DIAGNOSIS FUNCTION.....	4-42
4.5.1	Status by service (Smart extension).....	4-42

4.5.2	View Communication Module Log.....	4-44
4.6	SMART EXTENSION SYSTEM CONFIGURATION.....	4-47
4.6.1	Typical Configuration.....	4-47
4.6.2	Ring / Line configuration.....	4-48
4.6.3	Auto Speed Sync Operation.....	4-49
<b>CHAPTER 5</b>	<b>HIGH SPEED LINK SERVICE.....</b>	<b>5-1</b>
5.1	OVERVIEW.....	5-1
5.2	HS LINK SEND / RECEIVE DATA PROCESSING.....	5-2
5.3	HS LINK SETTING.....	5-3
5.3.1	Standard settings.....	5-3
5.3.2	HS Link Service.....	5-4
5.3.3	Communication device configuration (Smart I / O block v1 version).....	5-10
5.4	HS LINK OPERATION.....	5-18
5.5	HS LINK INFORMATION.....	5-24
5.5.1	High speed link flag.....	5-24
5.5.2	HS Link Information Monitor.....	5-26
5.6	XGR REDUNDANCY PROGRAM METHOD.....	5-28
5.6.1	When configuring an XGR redundant network.....	5-28
5.6.2	When configuring an XGR Single network.....	5-30
5.7	XGR REDUNDANT HIGH SPEED LINK SETTING PROGRAM.....	5-31
5.7.1	When configuring an XGR redundant network.....	5-31
5.7.2	When configuring an XGR Single network.....	5-38
5.8	ETHERNET SYSTEM CONFIGURATION.....	5-41
5.8.1	Configuration of Ethernet System Using Dedicated Network.....	5-42
5.8.2	Mix of Dedicated Networks and Third-Party Ethernet Systems.....	5-42
5.8.3	Mix of public, dedicated and third party Ethernet systems.....	5-43
5.8.4	System configuration using InfoU, PLC-to-PLC Dedicated Ethernet in XGR system.....	5-43
5.8.5	System configuration using single network Ethernet in XGR system.....	5-44
<b>CHAPTER 6</b>	<b>P2P SERVICE.....</b>	<b>6-1</b>
6.1	OVERVIEW.....	6-1
6.1.1	Overview of P2P service.....	6-1
6.1.2	P2P parameter configuration.....	6-1
6.2	TYPE OF P2P SERVICE.....	6-2
6.2.1	Type of P2P command.....	6-2
6.2.2	Type of P2P service.....	6-2
6.3	P2P SERVICE SETTING.....	6-4
6.3.1	Ethernet (server) driver.....	6-4

6.3.2	P2P channel.....	6-4
6.3.3	P2P block.....	6-7
6.4	P2P SERVICE OPERATION.....	6-9
6.5	USER FRAME DEFINITION.....	6-18
6.5.1	Overview of a user frame definition.....	6-18
6.5.2	User frame definition setting.....	6-18
6.5.3	Operation of a user frame definition.....	6-23
6.6	E-MAIL SERVICE.....	6-31
6.6.1	Email setting.....	6-31
6.6.2	Writing address.....	6-32
6.6.3	Create block.....	6-36
6.7	DOWNLOADING AND DIAGNOSIS OF P2P PARAMETER.....	6-37
6.7.1	Downloading a P2P parameter.....	6-37
6.7.2	P2P service operation.....	6-38
6.7.3	P2P service diagnosis.....	6-39
6.8	XGR REDUNDANCY PROGRAM METHOD.....	6-40
<b>CHAPTER 7 SERVER SERVICE.....</b>		<b>7-1</b>
7.1	XGT SERVER.....	7-1
7.1.1	Overview.....	7-1
7.1.2	XGT dedicated protocol commands.....	7-5
7.1.3	Server operation.....	7-14
7.2	MODBUS SERVER.....	7-17
7.2.1	Overview.....	7-17
7.2.2	Server operation.....	7-19
7.3	ETHERNET/IP SERVER.....	7-21
7.3.1	Overview.....	7-21
7.3.2	Operation Sequence.....	7-23
7.3.3	Parameter setting.....	7-24
7.3.4	Client setting.....	7-25
7.3.5	Server setting.....	7-31
7.3.6	Tag register.....	7-33
7.3.7	Setting Download.....	7-36
7.3.8	EtherNet/IP periodic communication operation example.....	7-37
7.3.9	Diagnosis.....	7-51
7.3.10	System configuration.....	7-52
7.4	OPCUA FUNCTION.....	7-53
7.4.1	Overview.....	7-54
7.4.2	Parameter setting.....	7-58

7.4.3	OPC UA settings.....	7-59
7.4.4	Variable registration.....	7-62
7.4.5	Setting Download.....	7-63
7.5	SERVER SERVICE USER SETTING FUNCTION.....	7-64
7.5.1	Overview.....	7-64
7.5.2	Setting Method.....	7-64
7.6	DNP3 SERVER.....	7-65
7.6.1	Overview.....	7-65
7.6.2	Server operation.....	7-65
7.6.3	DNP3 Parameter Setting.....	7-69
7.6.4	Diagnosis Global Variable.....	7-75
7.6.5	DNP3 Event Data log.....	7-76
<b>CHAPTER 8</b>	<b>ADDITIONAL FUNCTIONS.....</b>	<b>8-1</b>
8.1	REMOTE COMMUNICATION.....	8-1
8.2	XG5000 SETTING AND CONNECTION.....	8-2
8.2.1	Remote 1-stage connection (when using USB).....	8-2
8.2.2	Remote 2-stage connection (when using USB).....	8-4
8.2.3	CPU access directly from PC connected to Ethernet.....	8-6
8.3	SYSTEM CONFIGURATION USING SWITCH MODULE.....	8-9
8.3.1	Ethernet, RAPIenet mixed system configuration (supported by Ethernet V8.0 or higher, switch V2.0 or higher).....	8-9
8.4	COMMUNICATION MODULE OBJECT DATA SEND AND RECEIVE FUNCTION.....	8-11
8.4.1	SNTP object.....	8-12
8.4.2	Smart Extension object.....	8-28
8.4.3	P2P object.....	8-29
8.4.4	Diagnosis object.....	8-31
8.4.5	Ethernet Option object.....	8-41
<b>CHAPTER 9</b>	<b>TOUBLESHOOTING.....</b>	<b>9-1</b>
9.1	LEDERROR CHECK.....	9-2
9.1.1	Abnormal operation indication of XGL-EFMT / EFMF.....	9-2
9.1.2	Abnormal operation indication of XGL-EFMTB / EFMF.....	9-3
9.1.3	Abnormal operation display of XGL-EH5T.....	9-5
9.1.4	Abnormal operation display of XOL-ES4T/ES4H.....	9-6
9.2	ERROR CHECKING METHOD BY XG5000 CONNECTION.....	9-7
9.2.1	Error / Warning check during PLC operation.....	9-7
9.2.2	Error / Warning check during communication module operation.....	9-19
9.2.3	View Communication Module Log.....	9-33
9.3	XGT DEDICATED COMMUNICATION ERROR CODE.....	9-34

9.3.1	STATUS value that can be checked in communication frame.....	9-34
9.4	TROUBLESHOOTING BY ERROR .....	9-35
9.4.1	Troubleshooting .....	9-35
<b>CHAPTER 10</b>	<b>EMC STANDARD .....</b>	<b>10-1</b>
10.1	THE REQUIREMENTS FOR COMPLIANCE WITH EMC STANDARDS .....	10-1
10.1.1	EMC Standard.....	10-1
10.1.2	Panel .....	10-2
10.1.3	Cable.....	10-3
10.2	REQUIREMENT TO CONFORM THE LOW-VOLTAGE DIRECTIVE .....	10-4
10.2.1	Standards applicable to XGT series .....	10-4
10.2.2	Selection of XGT Series PLC .....	10-4
<b>APPENDIX</b>	<b>.....</b>	<b>A-1</b>
A.1	XGT CPU MEMORY DEVICE LIST .....	A-1
A.1.1	XGK CPU devices.....	A-1
A.1.2	XGI CPU devices .....	A-2
A.1.3	XGR CPU devices.....	A-2
A.2	DESCRIBES OF TERMS.....	A-3
A.3	LIST OF FLAGS.....	A-9
A.3.1	XGK CPU flags .....	A-9
A.3.2	XGI CPU flags.....	A-17
A.3.3	Communication relay (L) list.....	A-23
A.4	ASCII CODE TABLE.....	A-29
A.5	ETHERNET TECHNOLOGY COMPARE TABLE .....	A-31
A.6	DIMENSION.....	A-32



# Chapter 1 Overview

## 1.1 Guide to use this manual

This user's manual provides information on the performance specifications and operation methods of each product required to use the Ethernet (FEnet) module and switch module.

Classification	Item	Contents
Chapter 1	Overview	This chapter describes the structure of this manual, product features, and features provided by version.
Chapter 2	Product specifications	It describes the general specifications, performance specifications and cable specifications for PLC. Also, it describes part names and functions.
Chapter 3	Installation and trial operation	Installation method, setting sequence for operation, cable wiring precautions, trial operation (module registration, basic setting, download upload, link enable, system diagnosis). This section explains how to remove and replace the module.
Chapter 4	Smart extension service	Function overview, Smart extension service operation, Smart extension setting, Smart extension diagnosis function, Smart extension system.
Chapter 5	HS Link Service	Describes the function overview, high speed link service operation, high speed link setting, high speed link information, XGR redundancy program method and Ethernet system configuration.
Chapter 6	P2P service	Function overview, P2P service operation, P2P service setting, user frame definition overview, operation, setting, E-mail service, P2P parameter download and diagnosis, XGR redundancy program method are described. Please refer to Chapter 5 for system configuration.
Chapter 7	Server service	Function overview, XGT server operation, Modbus server overview, Modbus server operation, EtherNet / IP service operation, EtherNet / IP service setting, EtherNet / IP service diagnosis, EtherNet / IP system configuration, OPC UA function and OPC UA server setting. Please refer to Chapter 5 for system configuration.
Chapter 8	Additional service	This chapter describes remote communication control and system configuration using switch module.
Chapter 9	Troubleshooting	LED error check, module error check using XG5000, problem-specific troubleshooting, and communication error code.
Chapter 10	EMC Standard	Describes the requirements for compliance with EMC standards and the requirements for compliance with the Low Voltage Directive.
Appendix	-	This section describes the XGT CPU memory device list, term descriptions, flag list, communication relay (L) list, ASCII code table, and dimensions.

## 1.2 Characteristics

Ethernet is a 'technical standard' established by the IEEE, which enables easy network construction and high-speed, high-capacity data collection through CSMA / CD communication. Ethernet module is a module for data transmission between upper system such as PC device or PLC using electric / optical media. The Ethernet module supports TCP / IP and UDP / IP protocols and has the following characteristics.

### 1.2.1 Ethernet module

- Easy module change using module change switch of CPU and module change wizard of XG5000.
- Up to 24 Ethernet modules can be installed regardless of the main base and the extension base.(XGR CPU only supports main base)
- Media support based on the IEEE802.3 standard.
- Check parameter and service setting, module and network status using communication configuration tool (XG5000).
- Dynamic Host Configuration Protocol (DHCP) support for dynamically setting IP addresses.
- Provide access table to secure communication with host PC (HMI).
- Smart extension service for easy configuration and high speed data communication between our products.
- High speed link support for high speed data communication between our products.
- Possible to set high speed link block to transfer data between modules(Maximum transmission 32 blocks x 200 words, maximum reception 128 blocks x 200 words, maximum transmission and reception 128 blocks x 200 words). When using extension mode, RAPIEnet V2 high speed link supports a maximum of 256 blocks x 700 words for transmission, a maximum of 256 blocks x 700 words for reception, and a maximum of 256 blocks x 700 words for transmission and reception.
- Communication with up to 16 modules is available in addition to the high speed link.(Dedicated communication server + P2P communication) (up to 32 modules in Ethernet V6.0 or higher).
- The loader service through the Ethernet (XG5000) is supported: (Dedicated TCP/IP PORT: 2002).
- Easy connection with 3rd party modules (system) using P2P communication and XG5000.
- Support for dedicated protocols (XGT) and open protocols (EtherNet / IP, Modbus / TCP).
- Simple client function for communication between our communication module and other company's modules (Dedicated Communication, EtherNet / IP, Modbus / TCP, User frame definition client functions).
- Provides various diagnostic functions and module and network status information.
  - Status of communication module
  - Communication service(Smart extension, high speed link,P2P,Dedicated protocol server) status
  - The Auto Scan function that provides our module information connected to the network is provided.
  - The PING function that allows you to check the existence of another module is provided.
  - The type of packet and data average received by module are provided (Forecast the network load).
  - The function to diagnose the communication module through the network is provided.
- Provide email service(ASCII)
- Provide One IP Solution function

#### Notes

Supported OS versions of each function are as follows.

- 1) FEnet OS V 6.0 or higher: Support XGT Cnet dedicated protocol, MODBUS RTU protocol, MODBUS ASCII protocol ,RAPIEnet protocol.
- 2) FEnet OS V 8.0 or higher: Supported Smart extension service and EtherNet / IP protocol.
- 3) XGR CPU OS V2.4 or higher: One IP Solution function supported

### 1.2.2 Switch module

A switch module is a hub module that has a switching function for interfacing between XGT series Ethernet modules. Mounting XGT base module to connect PLC-to-PLC or system-to-system by Ethernet communication.

(1) Can be mounted on XGK / I / R base module (XGL-EH5T)

It can be mounted on XGT base without external power, and its compact size makes it easy to install in small spaces.

(2) Supported 1Gbps communication (XOL-ES4T, XOL-ES4H)

100M / 1Gbps communication can be selected. It also supports electric and optical mixing modules.

(3) Supported Ring configuration (XOL-ES4T, XOL-ES4H)

Ring 1 is available between Port1 and Port2, Ring2 is available between Port3 and Port4.

(4) Reliability of Industrial Device Standards

Compared to commercial switches, it guarantees environmental and noise reliability.

(5) Built-in crossover function (provides convenience in cable work)

Direct cables between routers and switch or between PC and switches, cross cables between routers and routers or switch and switches. Auto Crossover is a device that provides auto-detecting function and can be connected between same devices by direct cable.

(6) High speed link operation guarantee

Broadcast Storm, that is, the switch keeps broadcasting traffic and releases the function that causes network down, so the high speed link packet operates normally.

(7) Provide CHS (chassis) GROUND on RJ-45 connectors.

Transmission error rate is improved when using shielded cables (STP) on RJ-45 connectors.

### 1.2.3 Product name

This chapter describes the product configuration of the XGT Ethernet module.

Type	Content	Note	
XGK/ XGI / XGR Common	XGL-EFMT	10BASE-T/100BASE-TX	Category-5E or higher(STP)
	XGL-EFMF	100BASE-FX	Fiber Optic(SC)
	XGL-EFMTB	100BASE-TX/1000BASE-T	Category-5E or higher(STP)
	XGL-EFMHB	100BASE-TX/1000BASE-T 100BASE-FX/1000BASE-X	Category-5E or higher(STP) Fiber Optic(LC/SFP)
	XGL-EFMFB	100BASE-FX/1000BASE-X	Fiber Optic(LC/SFP)
	XOL-ES4T, XOL-ES4H	100BASE-TX/1000BASE-T 100BASE-FX/1000BASE-X	Category-5E or higher(STP) Fiber Optic(LC/SFP)
	XGL-EH5T	10/100BASE-TX	Category-5E or higher(STP)

#### Notes

(1) The XGT model does not support AUI (10BASE-5).

(2) Twisted pair cable unit (category 5E or higher) uses 100Mbps switch and can be mixed with existing 10Mbps (category 3 or less), but the In this case network speed is limited to 10Mbps.

Please be careful when installing the system

(3) XGL-EH5T can be used as a switch by mounting on XGT base module. It can be used by simply installing it without a program and has a speed of up to 100Mbps.

The XGL-EFMT / XGL-EFMF module is discontinued and can be replaced by XGL-EFMTB / XGL-EFMFB.

### 1.2.4 Function Items by Version

The function items provided by each version are as follows.

Model name			Function
XGL-EFMTB XGL-EFMFB XGL-EFMHB (V8.0 or higher)	XGL-EFMTB XGL-EFMFB (V6.0 or higher)	XGL-EFMT XGL-EFMF (V5.0 or less ) XGL-EFMTB XGL-EFMFB (V6.0 or less )	
Supported	Supported	Supported	High speed link service, P2P service (XGT Enet, Modbus TCP), Server service, Remote service.
Supported	Supported	Unavailable	XGT Cnet client, Modbus RTU/ASCII client, RAPIEnet client
Supported	Unavailable	Unavailable	EtherNet/IP service Smart extension service
Unavailable	Unavailable	Unavailable	OPC UA server service(Only version 7.x support)

### (1) HS Link Service

The high speed link is the communication method between the XGT PLC and XGB PLC communication modules and data is transmitted and received periodically according to the high speed link parameter setting. The high speed link service transmits a frame to the subnet broadcast using the UDP protocol. Devices in the same subnet receive broadcast frame at the same time, and if the relevant frame is registered in the reception list, the data it will processed.

### (2) P2P service

The P2P service is the client function in the following client/server model. This function requests the server for reading/writing data. When the starting condition of each block is On, this function creates a request frame with the protocol specified as the relevant channel, receives and processes the response.

The parameter consists of up to 64 P2P blocks.

### (3) Server service

Dedicated communication (server) service is a protocol of Ethernet module that can read and write information and data of PLC from PC and peripheral devices. Ethernet operates as a server in a communication network and responds to memory read or write requests from an external device or PC using the XGT protocol or Modbus TCP protocol. TCP port 2004 and UDP port 2005 are used for XGT dedicated driver of Ethernet module, and Modbus TCP driver uses TCP 502. The dedicated service means the server function in the following client/server model. The client connects to the server and read and write data according to the set protocol. The server performs the functions of ② reception detection and ③ response transmission.

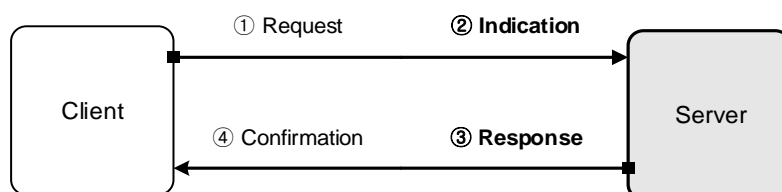

### (4) Remote service

Remote service function is a function that can control programming, downloading user programs, debugging program and monitoring etc. in the network system where PLC is connected to each other by Ethernet without using XG5000 direct connection with communication module.

### (5) EtherNet / IP service

EtherNet / IP is a protocol that puts Common Industrial Protocol (CIP: Common Industrial Protocol such as DeviceNet, ControlNet, CompoNet, etc.) to the upper layer to the open protocol Ethernet. EtherNet/IP therefore enables DeviceNet, ControlNet, and CompoNet product developers, system integrators and users to apply the same objects and profiles to ensure interoperability between multi-vendor and sub-network devices. In addition, it provides two Ethernet ports, and has built-in switch functions necessary for the existing star method, and is a module for data transmission between PLCs or between PLCs and EtherNet/IP supported IO modules.

(6) OPC UA server service

OPC Unified Architecture (IEC 62541) is an interoperability standard for secure and reliable information exchange, making it suitable for industrial applications. Based on client-server model, it is a communication protocol applicable from sensor level to cloud and has the following features.

Multi / cross platform support

Unlike OPC Classic, which was dependent on the Windows operating system, it can be operated on an embedded device without being limited to one operating system or programming language.

- Strong security

Supports authentication and authorization through signing, encryption and data integrity, and uses X.509 certificates for authentication.

- Service Oriented Architecture

(7) Smart extension service

Smart extension service is a service between Ethernet (B type) module and communication device (expansion driver, Smart I / O extension, Smart I / O block) product. It is a service that can control and monitor multiple connected PLCs with simple setting. Among EtherNet / IP functions, scanner functions are integrated in the Smart expansion service.

(8) RAPIEnet service

Based on Ethernet communication, it communicates between XGT series PLCs and provides two Ethernet ports capable of line (daisy chain) and ring configuration. It provides a flexible network configuration method compared to the existing STAR type PLC-to-PLC communication module. The RAPIEnet module is divided into two electric ports (100BASE-TX /1000BASE-T), two optical ports (100BASE-FX/1000BASE-X) and mixed (100BASE-TX/1000BASE-T, 100BASE-FX//1000BASE-X) according to the media type. This service is for data transmission.

(9) Ethernet switch

It uses CSMA / CD to control communication, establishes an easy network, and enables high-speed, high-capacity data collection.

(10) RAPIEnet switch(MRS)

MRS(Multi-port RAPIEnet Switch) is based on Ethernet and can be configured in a ring / line topology and enables high speed and high capacity data collection. It acts as a switch to connect between its our RAPIEnet network modules.

Notes		
(1) Interoperability is a feature that enables seamless communication between information system devices and services of the same or different types, and provides the ability to accurately perform information exchange or a series of processes.		
(1) The applicable products by product category are shown in the table below.		
Product category	Product	Note
Extension driver	XGL-DBDT, XGL-DBDF, XGL-DBDH	
Smart I/O expansion	XEL-BSSRT, XEL-BSSRF, XEL-BSSRH	
Smart I/O block	GEL-TR4C1/TR4C, GEL-DT4C1/DT4C, GEL-D24C, GEL-RY2C, GEL-AV8C, GEL-AC8C, GEL-DV4C, GEL-DC4C	

1.2.5 Number of units that can be installed for each CPU

Up to 24 Ethernet modules can be mounted regardless of the main base or extension base. For maximum performance of the communication module, mount it on the main base where possible. The table below shows the types of services available for each CPU.

Classification	XGK								XGI						XGR		
	CPU E	CPU S	CPU A	CPU H	CPU U	CPU SN	CPU HN	CPU UN	CPU E	CPU S	CPU H	CPU U	CPU U/D	CPU UN	CPU H/T	CPU H/F	CPU H/S
HS Link Service	12 units														6 units		
P2P service	8 units														6 units		
Server service	24 units														6 units		

**Notes**

(1) In XGR system, Ethernet is available only for the main base.

## 1.3 Software for using the product

Describes programming tools and other CPU software for using the Ethernet module. For use, please refer to the following and apply it to the system.

### 1.3.1 Software checklist

#### (1) Ethernet module

Classification	Service/Driver adding	XGK CPU	XGI CPU	XGR CPU	Programming tools (XG5000)
XGL-EFMT XGL-EFMF	-	XGK-CPUE: V2.0 or higher XGK-CPUSN: V1.00 or higher	XGI-CPUE: V3.30 or higher XGI- CPUUN: V1.10 or higher	V1.3 or higher	V2.4 or higher
XGL-EFMTB XGL-EFMFB (V5.0 or higher)	-	XGK-CPUE : V4.55 or higher XGK-CPUSN: V1.05 or higher	XGI-CPUE: V4.57 or higher XGI- CPUUN: V1.12 or higher	V2.72 or higher	V3.71 or higher
XGL-EFMTB XGL-EFMFB (V6.0 or higher)	1.P2P Service Driver - XGT Cnet client - Modbus ASCII client - Modbus RTU client - RAPIenet client 2. RAPIenet protocol - RAPIenet v1 3. High speed link station type - RAPIenet 4. Smart server function	XGK-CPUE : V4.57 or higher XGK-CPUSN: V1.21 or higher	XGI-CPUE: V4.08 or higher XGI- CPUUN: V1.31 or higher	V2.72 or higher	V3.71 or higher
XGL-EFMTB XGL-EFMFB (V7.0)	1, OPC UA server function	XGK-CPUE : V4.57 or higher XGK-CPUSN: V1.21 or higher	XGI-CPUE: V4.08 or higher XGI- CPUUN: V1.31 or higher	V2.73 or higher	V4.25 or higher
XGL-EFMTB XGL-EFMFB XGL-EFMHB (V8.0 or higher)	1. Smart extension service 2. EtherNet / IP service	XGK-CPUE : V4.57 or higher XGK-CPUSN: V1.21 or higher	XGI-CPUE: V4.08 or higher XGI- CPUUN: V1.31 or higher	Unavailable	V4.30 or higher
	3. RAPIenet protocol - RAPIenet v2 4. P2P source port setting function	XGK-CPUE : V4.57 or higher XGK-CPUSN: V1.21 or higher	XGI-CPUE: V4.08 or higher XGI- CPUUN: V1.31 or higher	V2.72 or higher	V4.30 or higher
	5. Command - SNDUDATA - RCVUDATA - SEND_UDATA - RCV_UDATA	XGK-CPUE : V4.70 or higher XGK-CPUSN: V1.40 or higher	XGI-CPUE: V4.11 or higher XGI- CPUUN: V1.50 or higher	V2.81 or higher	V4.30 or higher
XGL-EFMTB XGL-EFMFB XGL-EFMHB (V8.1 or higher)	1. User port change function 2. RAPIenet Auto scan save/compare function 3. RAPIenet+ Auto Scan function	XGK-CPUE : V4.57 or higher XGK-CPUSN: V1.21 or higher	XGI-CPUE: V4.08 or higher XGI- CPUUN: V1.31 or higher	V2.72 or higher	V4.50 or higher

	2. Command - MSETIP - MNETINFO - M_SET_IP - M_NET_INFO	XGK-CPUSN: V1.40 or higher	XGI- CPUUN: V1.50 or higher	Unavailable	V4.50 or higher
XGL-EFMTB XGL-EFMFB XGL-EFMHB (V8.3 or higher)	1. High-speed link receive timeout setting function 2. SNMP function	XGK-CPUE : V4.57 or higher XGK-CPUSN: V1.21 or higher	XGI-CPUE: V4.08 or higher XGI- CPUUN: V1.31 or higher	V2.72 or higher	V4.51 or higher
	3. Command - MGETLED - M_GET_LED	XGK-CPUSN: V1.50 or higher	XGI- CPUUN: V1.61 or higher	Unavailable	V4.51 or higher
XGL-EFMTB XGL-EFMFB XGL-EFMHB (V8.4 or higher)	1. 100Mbps auto-negotiation speed limit function	XGK-CPUE : V4.57 or higher XGK-CPUSN: V1.21 or higher	XGI-CPUE: V4.08 or higher XGI- CPUUN: V1.31 or higher	V2.72 or higher	V4.52 or higher
XGL-EFMTB XGL-EFMFB XGL-EFMHB (V8.7 or higher)	1. Expand the number of high speed link blocks (Only supported by XGI-CPUZ) 2. Smart expansion EB number expansion (63 -> 127)	-	XGI- CPUUN: V2.00 or higher XGI- CPUZ7: V1.50 or higher	-	V4.73 or higher
XGL-EFMTB XGL-EFMFB XGL-EFMHB (V8.8 or higher)	1. DNP3 Server	-	XGI-CPUE: V4.30 or higher XGI- CPUUN: V2.00 or higher XGI- CPUZ7: V1.50 or higher	-	V4.76 or higher
XGL-EFMTB XGL-EFMFB XGL-EFMHB (V9.0 or higher)	1. Input data clear function when high-speed link timeout occurs 2. RAPIenet Generic Slave Function	-	-	-	V4.78 or higher
XGL-EFMTB XGL-EFMFB XGL-EFMHB (V9.1 or higher)	1. XGR Smart extension service (Supports only EtherNet/IP message service)	-	-	V3.10 or higher	V4.78 or higher

- 1) In the table above, XGK-CPUE includes both XGK-CPUE/S/A/H/U.
- 2) In the table above, XGI-CPUE includes both XGI-CPUE/S/SP/H/U/UD.
- 3) In the table above, XGI-CPUSN includes both XGK-CPUSN/HN/UN.
- 4) In the table above, XGI-CPUZ7 includes both XGI-CPUZ3/5/7.

(2) Switch

Classification	Service/Driver adding	XGK CPU	XGI CPU	XGR CPU	Programming tools (XG5000)
XOL-ES4T (V1.x)	RAPIenet v1	-	-	-	- Not programmable - Some of the diagnostics available
XOL-ES4T (V2.0 or higher)	RAPIenet v2				
XOL-ES4H	RAPIenet v2				
XGL-EH5T	Ethernet	-	-	-	-

## Notes

(1) The above program can be downloaded and used from the current website. If you cannot use the Internet, visit the nearest distributor and use the installation CD-ROM.

Website address: <http://www.ls-electric.com/>

(2) XG5000 can be programmed with RS-232C port and USB of CPU module. Refer to XGK CPU Module or XGI CPU Module User's Manual for wiring type.

(3) Some functions may not work normally if a version other than stated above is used. Please check compatibility.

## 1.3.2 Checking the product information

## (1) Checking the version

Check the version of the module before using the Ethernet module.

Check the module information by double clicking the Ethernet module on [XG5000] → [Online] → [Communication module setting and diagnosis] → [System Diagnosis].

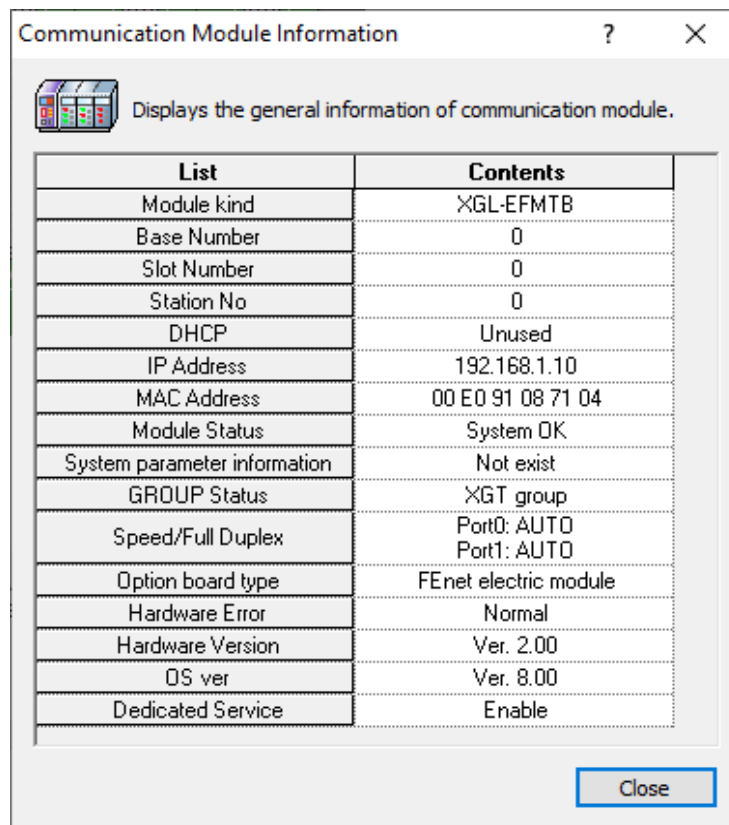

## (2) Check the version via the case label on the product.

For each communication module, product information of the module is attached to the outer case. After detaching a module without a connection with a PC, a label is attached to the back of the module and the model name and version information are indicated.

## Chapter 2 Product specifications

### 2.1 General specifications

The general specifications of the XGT series are as follows.

No	Item	Specifications	Related specifications			
1	Operating ambient temperature	0 ~ 55 °C				
2	Storage temperature	-25 ~ +70 °C				
3	Ambient humidity	5 ~ 95%RH (Non-condensing)				
4	Storage humidity	5 ~ 95%RH (Non-condensing)				
5	Vibration resistance	In case of occasional vibration			-	IEC 61131-2
		Frequency	Acceleration	Amplitude	Times	
		5≤f< 8.4 Hz	-	3.5mm	X, Y, Z Each direction 10 times	
		8.4≤f≤150 Hz	9.8 m/s <sup>2</sup> (1G)	-		
		In case of continuous vibration				
		Frequency	Acceleration	Amplitude		
5≤f< 8.4 Hz	-	1.75mm				
		8.4≤f≤150 Hz	4.9m/s <sup>2</sup> (0.5G)	-		
6	Shock resistance	<ul style="list-style-type: none"> <li>•Peak impact acceleration: 147 m/s<sup>2</sup> (15G)</li> <li>•Duration : 11 ms,</li> <li>•Pulse waveform: Half-sine (3 times for each direction of X, Y and Z)</li> </ul>	IEC 61131-2			
7	Noise resistance	Square wave impulse noise	AC : ±1,500V,DC : ±900V		Test standard of LS ELECTRIC	
		Electrostatic discharge	4.0kV (Contact discharge)		IEC 61131-2 IEC 61000-4-2	
		Radiated electromagnetic field noise	80 ~ 1000 MHz, 10V/m		IEC 61131-2, IEC 61000-4-3	
		Fast transient /burst noise	Classification	Power module	Digital/Analog Input/Output, Communication Interface	IEC 61131-2 IEC 61000-4-4
Voltage	2kV		1kV			
8	operating atmosphere	Free from corrosive gases and excessive dust				
9	Operating altitude	Up to 2,000m				
10	Pollution degree	Less than equal to 2				
11	Cooling method	Air cooling				

#### Notes

(1) IEC (International Electrotechnical Commission): An international nongovernmental organization which promotes international cooperation in the standardization in the fields of electricity and electronics, publishes international standards and operates relevant conformity assessment systems.

(2) Pollution degree: An index indicating pollution degree of the operating environment which decides insulation performance of the devices. For instance, Pollution degree 2 indicates the state generally that only non-conductive pollution occurs. However, temporary conduction occurs in this state due to dew formation.

## 2.2 Performance specifications

Please refer to the table below when configuring the system.

Item		Specifications			
		Driver	Communication method	Port number	Note
Classification	HS Link Service	FEnet	UDP/IP	2006	Up to 128 blocks 200 words per block
		RAPIEnet	-	-	Up to 128 blocks, 200 words per block Up to 256 blocks, 700 words when using high speed link block expansion
	P2P service	XGT Enet client	TCP/IP	2004	Up to 8 P2P parameters Up to 32 channels per parameter Up to 64 blocks per parameter setting Up to 1400 Byte per blocks
			UDP/IP	2005	
		XGT Cnet client	TCP/IP	2004	
			UDP/IP	2005	
		Modbus TCP/RTU/ASCII client	TCP/IP	502	
		RAPIEnet client	-	-	
		User frame definition	TCP/IP	Specified by the user	
	UDP/IP		Specified by the user		
	E-mail	-	-	Up to 128 address	
	Smart extension service	-	RAPIEnet v2, EtherNet/IP	-	Max. 64 station
	EtherNet/IP Service	Explicit message server, Adapter	UDP/IP (I/O data)	2222 (I/O data)	Adapter: Up to 64 tag Maximum number of connections: 64 (I/O data + Explicit)
		Explicit message client, Scanner	TCP/IP (Explicit)	44818 (Explicit)	Up to 64 channels
	Server service (Dedicated communication)	XGT server	TCP/IP	2004	Up to 64 channels Up to 1400 bytes
UDP/IP			2005		
	Modbus Server	TCP/IP	502		
OPC UA server	-	TCP/IP	4840(default) Specified by the user	Maximum client 10 modules	
Remote service	Server	UDP/IP	2007/2008		

### Notes

- (1) In case of server service (dedicated communication), Ethernet OS version less than V6.0 supports up to 16 channels.
- (2) In case of P2P service, Ethernet OS version supports up to 16 channels under V6.0.

2.2.1 Ethernet module

Item		XGL-EFMT	XGL-EFMTB	XGL-EFMF	XGL-EFMFB	XGL-EFMHB
Transfer Specifications	Transmission speed(Mbps)	10/100	10/100/1000	100	100/1000	Electric: 10/100/1000 Optical :100/1000
	Transmission method	Baseband				
	Maximum distance between nodes	100m (Node-Switch)		2km (Multi-mode)		Electric:100m Optical: 2km
	Minimum distance between nodes	Recommend 1m or higher <small>note1)</small>		-		Electrical: Recommend 1m or higher <small>note1)</small>
	Send media	Electrical: Category 5E or higher STP (Shielded Twisted-pair) cable Optical: Multi mode(MMF)/Single mode(SMF) cable				
	Maximum protocol size	1,500 Byte				
	Communication network access method	CSMA/CD				
	Frame error check method	CRC32				
Max. load	EFMT/EFMF: 1,200pps EFMTB/EFMFB/EFMHB(Ethernet):10,000pps,RAPINet: 40,000pps					
Topology	RAPINet used: line, ring(Use MRS when using other topologies) RAPINet not used - Line, tree, star (use switch) - DLR(Ring node) <small>note2)</small>					
Diagnosis function	Station number / IP collision detection function, diagnosis using XG5000					
IP setting method	XG5000, DHCP					
Station number setting range	Station number setting value set by XG5000 (0 to 220)					
External connecting terminal	RJ45, SFP : PADT connection, data communication					
RAPINet Service Specifications	Data processing unit	Byte(8bit)				
	Max read/write data size	1,400 byte <sup>note3)</sup>				
	Max No. of connected stations per network	64 station (However, MRS is not included in the number of connected stations, and is limited to 12.)				
EtherNet/IP Service specifications	Data processing unit	Byte(8bit)				
	Max read/write data size	Non-periodic tag: 1400 Bytes Periodic <sup>Note4)</sup> : 1,400 Bytes				
	Available communication type	Connection type(Periodic ) message: class1 Non connection type(Non-periodic ) message: tag, Object				
	Maximum number of connections	Connection-type (periodic)+ Non connection type(Non-periodic ):64				
Modbus / TCP service specifications	Data processing unit	Word(16bit),bit				
	Max read data size	125 Word(2,000 Bits)				
	Max write data size	123 Word(1,968 Bits)				
	Maximum number of connections	64				

Basic Specifications	Current consumption(mA)	100Mbps	410	560	630	750	670
		1Gbps	-	900	-	740	830
	Weight(g)		105	146	120	130	120

\*Note 1) When using a cable shorter than 1m, the signal to noise ratio (SNR) is lowered due to the effect of reflected waves, so link down or packet loss may occur.

\*Note 2) DLR (Ring node) only works with XGL-EFMTB/EFMFB/EFMHB V8.60 or higher.

\*Note 3) It is the size when connecting with communication device.

\*Note 4) The I / O refresh size can only be accessed by an Originator that supports Large Forward Open (0x5B) if it is greater than or equal to 512 bytes including the header. The input header size consists of a 2-byte PDU sequence number, the output header size includes a 2-byte PDU sequence number and 4 bytes of Run-Idle information. Run-Idle information 4 bytes are determined according to the setting value of EDS.

**Notes**

(1) Baud rate can be set as shown above when RAPIenet is set to Disable. However, when setting RAPIenet v1 in driver setting, only 100M is supported for electrical and optical ports, and setting 100/1000 for electrical and optical ports when setting to RAPIenet v2.

**2.2.2 Switch module**

Item		RAPIenet		Ethernet
		XOL-ES4T,	XOL-ES4H	XGL-EH5T
Transfer Specifications	Transmission speed	100Mbps(1,2 port) 100Mbps/1Gbps (3,4port)	100Mbps/1Gbps (1,2port,electric) 100Mbps/1Gbps (3,4port,optical)	10/100Mbps
	Port type and number of ports	XOL-ES4T: 100BASE-TX, 2 port, 100BASE-TX/1000BASE-T 2 port XOL-ES4H:100BASE-TX/1000BASE-T 2 port, 100BASE-FX/1000BASE-X 2port		10/100BASE-TX, 5 port
	Transmission distance	100m	100m/2km	100m
	Diagnosis function	LED display	LED display	LED display
IP allocation		192.168.1.xx (xx: 100 + station number switch 1~99)		-
Basic Specifications	Power supply(DC)	24V(Input range: 20.4~28.8V)		5V(supply from base module)
	Current consumption(mA)	300	300	550
	Weight(g)	200	280	90

### 2.2.3 Power specification

(1) Switch module(XOL-ES4T/ XOL-ES4H)

Item	Specifications
Input power	DC 24V(Input range: 20.4~28.8V)
input current	0.3A (+24VDC)
Power display	RUN LED ON at power input

#### Notes

1. Use UL approved power supply

Use a power supply that meets Class 2 or that meets the Limited voltage limited circuit (LVLC) requirement.

### 2.2.4 Load specifications

Communication load is divided into the load by media interrupt received per second from Ethernet media and the transmission load transmitted by CPU module to Ethernet module. If the load due to the media interrupt guaranteed by the Ethernet module and the transmission load are exceeded, it may not operate normally.

(1) Communication load due to media interrupt

- 1) The amount of packets generated per second due to the load on the data frames delivered to the media is measured.
- 2) The maximum load of the Ethernet module delivered to the media (based on server operation) is up to 10,000 packages / sec.
- 3) Checking method: XG5000 -> [Online]-> Communication module setting and diagnosis-> [System Diagnosis] After clicking Ethernet module, you can check packet rate per second in [Media Information].

The screenshot shows a 'Media Information' dialog box with a close button (X) in the top right corner. It contains two sections: 'Standard Information' and 'Detailed information:'. In the 'Standard Information' section, there are two input fields: 'Base No.:' with the value '0' and 'Slot No.:' with the value '1'. The 'Detailed information:' section contains a table with the following data:

Section	Broad	Multi	Uni	UDP	ARP(EARP)	Throw out
Total packets	0	0	0	0	0	0
No. of Packets per second	0	0	0	0	0	0

At the bottom of the dialog box, there are three buttons: 'Read', 'Refresh', and 'Close'.

- 4) If the maximum load is exceeded, an error in the operation of the Ethernet module, such as a communication error, a diagnostic service failure, or a remote connection failure occurs.
- 5) Even if the receive block is not set in HS link parameter, the load is increased because media interrupt occurs.
- 6) When the maximum load is exceeded, change the communication cycle of the Ethernet module where high speed link transmission is set.  
ex) 20ms → 200ms

### Notes

- (1) XGL-EFMT/EFMF : approximately 1,200 packet/sec, XGL-EFMTB/EFMFB/ EFMHB : approximately 10,000 packet/sec
- (2) In B type Ethernet, 10,000 packets / sec is overloaded even when more than 1,100 packets are received in 100ms based on instantaneous load.

(2) Transmission load of XGK / I / R system (load by the amount of data transferred by CPU module to communication module)

- 1) The transmission load is determined by the communication module scan time, HS link service cycle and P2P service setting of the CPU module.
- 2) Maximum number of HS link transmission blocks on Ethernet module:  $(\text{HS link transmission cycle} / \text{CPU maximum scan}) \times 8 \text{ blocks}/2$   
The maximum HS link transmission / receive load is exceeded, change HS link transmission cycle or block number.

## 2.3 Structure and Characteristics

### 2.3.1 Names of Part and Function

(1) XGL-EFMT/XGL-EFMF

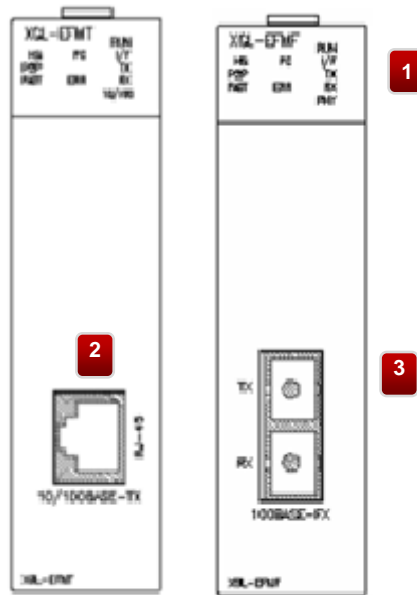

#### <Name of each part>

No.	Name	Content
1	LED Display	Please refer to the content below.
2	Communication Connector	It is a connector for electric cable for connecting Ethernet communication with external device.
3		It is a connector for optical fiber cable for Ethernet communication with external device.

#### <Names of LED and Function>

Names of LED	Indication contents of LED	LED status	Functional description
RUN	Display module operation status	ON	Normal operation.
		Off	Do not normal operation.
HS	Display High speed link service operation state.	ON	High speed link service operates normally.
		Off	High speed link service does not operate normally.
P2P	Display P2P service operation state	ON	P2P service operates normally.
		Off	P2P service does not operate normally.
PADT	Display Smart extension service operation state.	ON	Operating remote service with remote Ethernet communication device (including PC).
		Off	Remote service operation is disabled.

Names of LED	Indication contents of LED	LED status	Functional description
PC	Display server service operation state	ON	Operating server service with remote Ethernet (including PC).
		Off	Server service operation is disabled.
ERR	Display module failure state	ON	Communication with the CPU module is not normal. The module is critical error.
		Off	Normal operation.
TX	Display send operation status	ON	Sending data.
		Flickering	When sending stops repeatable during transmission.
		Off	Do not sending data
RX	Display receive operation status	ON	Receiving data.
		Flickering	When receiving stops repeatable during receive.
		Off	Do not receiving data
PHY	Display communication speed	ON	The communication network is connected 100Mbps
		Off	The communication network is connected 10Mbps

(2) XGL-EFMTB/XGL-EFMFB/ XGL-EFMHB

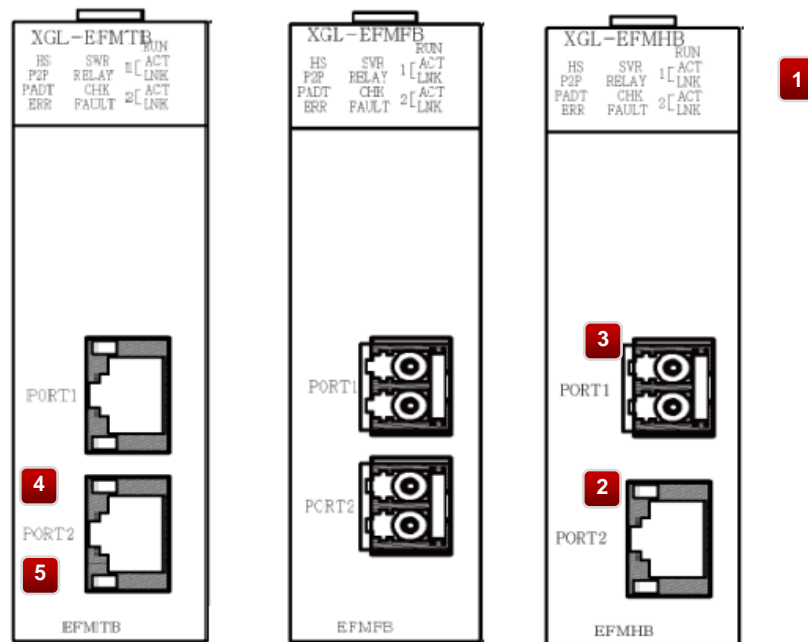

<Name of each part>

No.	Name	Content
1	LED Display	Please refer to the table.
2	Communication Connector	It is a connector for electric cable for connecting Ethernet communication with external device.
3		It is a connector for optical fiber cable for Ethernet communication with external device.
4	RJ-45 ACT (Yellow)	ON: when data is transmit or receive. Flickering: Flashes when sending and stopping are repeated, during transmission. Off: Do not sending or receiving data.
5	RJ-45 LNK (Orange & Green)	Shows link speed when link partner and link are connected (when Link LED is on). - Green ON: 1Gbps - Orange ON: 100Mbps - Off : 10Mbps (Link LED is on and RJ45 LNK LED is off)

<Names of LED and Function>

Names of LED	Indication contents of LED	LED status	Functional description
RUN	Display module operation status	ON	Normal operation.
		Off	Do not normal operation.
HS	Display High speed link service operation state.	ON	High speed link service operates normally.
		Off	High-speed link service is canceled.
P2P	Display P2P	ON	P2P service operates normally.

Names of LED	Indication contents of LED	LED status	Functional description
	service operation state	Off	High-speed P2P service is canceled.
PADT	Display Smart extension service operation state.	ON	Operating remote service with remote Ethernet communication device (including PC).
		Off	Remote service operation is disabled.
ERR	Display module failure state	ON	The product is critical error due to a failure in communication with the CPU module or an H / W failure.
		Off	Normal operation.
SVR	Display server service operation state.	ON	Indicates that the remote Ethernet communication device (including PC) is in service by connecting to the server service.
		Off	There are no clients connected to the server service.
RELAY	Display relay service operation state.	ON	When the Relay option of the basic parameter is checked and the media speed of Port 1 and Port 2 is the same, the data frame can be relayed.
		Flickering	The relay option of the basic parameter is checked and the communication speed of the two ports is different, so the frame cannot be relayed. (V6.0 or higher)
		Off	The frame cannot be relayed.
CHK	Display Check LED operation state	ON	<ul style="list-style-type: none"> <li>- There is no basic parameter.</li> <li>- There is a basic parameter error.(Module type, Media type, IP setting error)</li> <li>- There is RAPIenet slave parameter error.(V6.0 or higher)</li> <li>- There is a station number conflict on the RAPIenet network.(V6.0 or higher)</li> <li>- Transceiver recognition fails when the media setting for SFP is Auto(V8.0 or higher)</li> <li>- This is the case with CPU version that does not support TAG. (V8.0 or higher)</li> <li>- In case of EtherNet / IP tag or smart expansion tag error. (V8.0 or higher)</li> </ul> * For details, please check the history of XGL-EFMxB.
		Flickering (V6.0 or higher)	OS or parameters are being written to flash memory. - RAPIenet network change over switching ring→line If there is a lot of communication data and you discard the received data.
		Off	Normal operation.
FAULT	Display FAULT LED operation state.	ON	<ul style="list-style-type: none"> <li>- Station number conflict occurred When RAPIenet was set. (V6.0 or higher)</li> <li>- IP conflict or operating Flash Erase.</li> </ul> In case error occurs when using the smart extension service (V8.0 or higher). * For details, please check the history of XGL-EFMxB.
		Flickering	Communication frame errors (CRC errors and other error handling). (Automatically turned off after 30 ms On) - In case of Smart I / O drop out during Smart I / O control with RAPIenet V1. (V6.0 or higher) In case the slave with hot swap is dropped while operating smart expansion service (V8.0 or higher). * For details, please check the history of XGL-EFMxB.
		Off	Normal operation.

Names of LED	Indication contents of LED	LED status	Functional description
ACT	Display ACT LED operation state.	ON	Sending and receiving data.
		Flickering	When sending stops repeatable during transmission.
		Off	Do not sending or receiving data.
LINK	Display LINK LED operation state	ON	When the communication network is connected. * Please refer to the RJ-45 LNK LED specification for LINK speed.
		Off	When the communication network is not connected.

### Notes

(1) Relay function is not supported at 0Mbps, so if Relay option is checked at 10Mbps, Relay LED will be off.

(3) XGL-EH5T

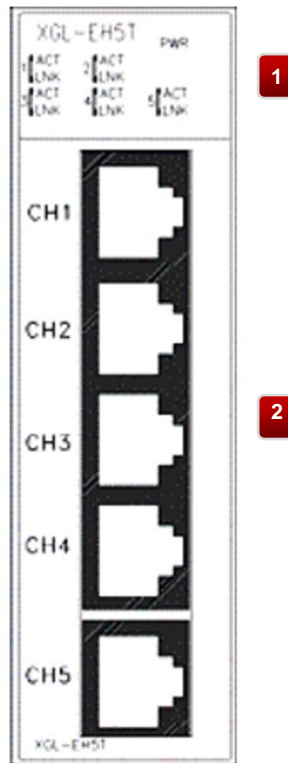

<Name of each part>

No.	Name	Content
1	LED Display	Please see below.
2	Communication Connector	It is a connector for electric cable for connecting Ethernet communication with external device.

<Names of LED and Function>

Names of LED	Indication contents of LED	LED status	Functional description
PWR	Display module power status	ON	Displays the power On status of the module.
		Off	Displays the power off status of the module.
ACT	Display send/receive operation status by port	ON	-
		Flickering	Port 1 data send/receive is in progress.
		Off	Port 1 data transmission / reception does not operation.
LNK	Display communication speed status by port	ON	Port 1 100Mbps communication is connected.
		Flickering	-
		Off	Port 1 10Mbps communication is connected.

(4) XOL-ES4T/ XOL-ES4H

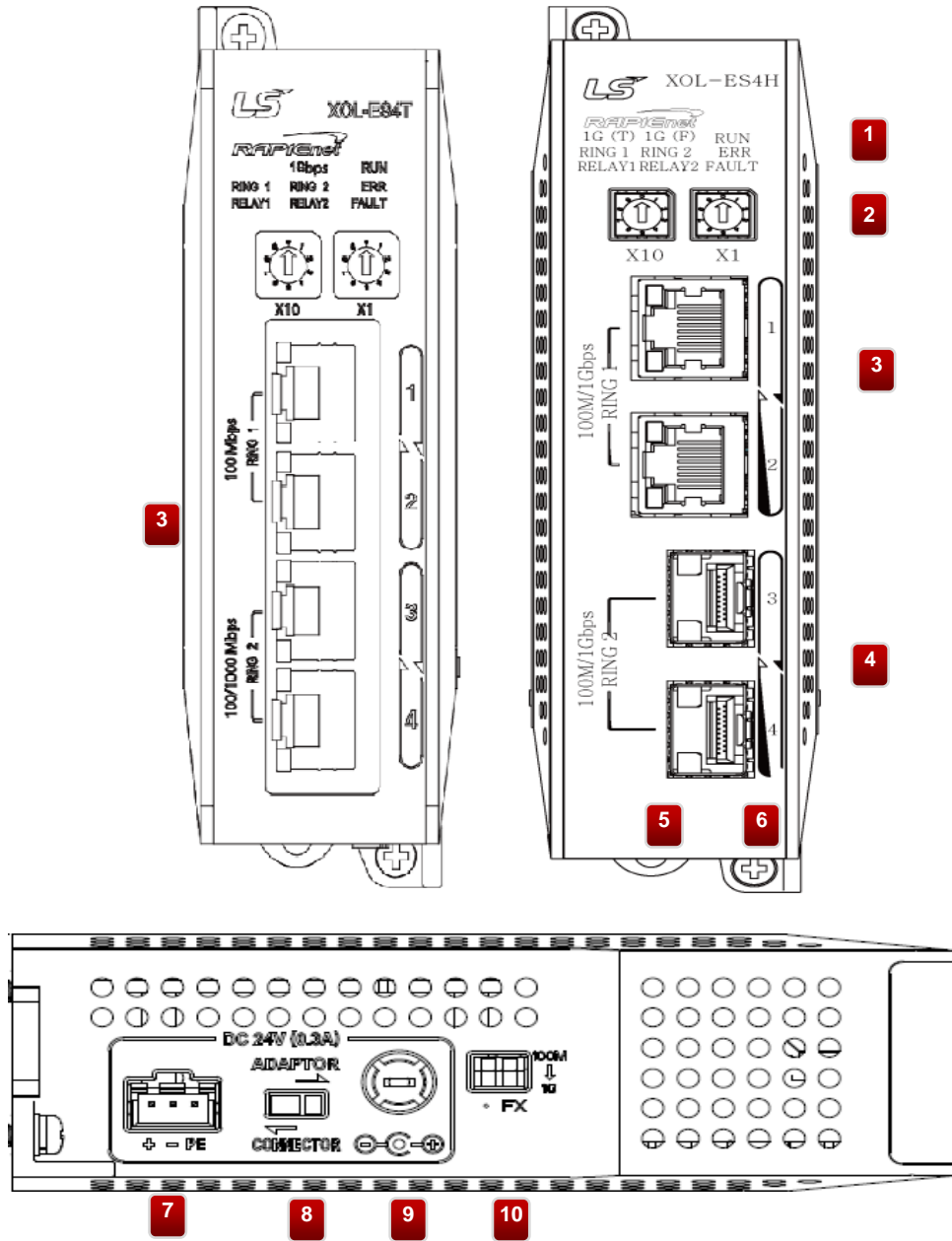

<Name of each part>

No.	Name	Content
1	LED Display	Please see below.
2	Station number	The station number of the product can be set from 0 to 99.
3	Communication Connector	It is a connector for electric cable for connecting Ethernet communication with external device.
4		It is a connector for optical fiber cable for Ethernet communication with external device.
5	Hook for DIN Rail fixation	Hook for fixing the product when mounted on DIN rail.
6	Fixed hole	Hole for fixing the product to the panel.
7	Power supply connector	This connector is for DC 24V power supply. +, -, PE 3 terminals in that order.
8	power switch	This switch selects the power supply. Select the left side when supplying power to the power supply connector and the right side to the adapter terminal.
9	Terminal for the adapter	Adapter power input terminal block Currently unused power switch must be used to the left.
10	Optical communication speed selector switch	100M / 1G selection switch when using optical connector. The speed is automatically adjusted according to the optical connector communication speed of the connected external device. Therefore, no setting is necessary.

<Names of LED and Function>

Names of LED	Indication contents of LED	LED status	Functional description
RUN	Display module power status	ON	Normal operation.
		Off	This is not a normal operation.
1Gbps (XOL-ES4T)	Display communication speed status by port	ON	Ports 3 and 4 are communicating at 1 Gbps.
		Off	Ports 3 and 4 are communicating at 100Mbps.
1G(T) (XOL-ES4H)	Display communication speed status by port	ON	Ports 1 and 2 are communicating at 1 Gbps.
		Off	Ports 1 and 2 are communicating at 100Mbps.
1G(F) (XOL-ES4H)	Display communication speed status by port	ON	Ports 3 and 4 are communicating at 1 Gbps.
		Off	Ports 3 and 4 are communicating at 100Mbps.
RING1	Network Topology Display by Port	ON	Ports 1 and 2 are changed to the ring topology.
		Off	Ports 1 and 2 are changed to the line topology.
RING2	Network Topology Display by Port	ON	Ports 3 and 4 are changed to the ring topology.
		Off	Ports 3 and 4 are changed to the line topology.
ERR	Display module failure state	ON	H/W is critical error.
		Off	Normal operation.
RELAY1	Display Relay operation status by port	ON	Ports 1 and 2 operate when the data frame operates as a relay.
		Off	This is the case when ports 1 and 2 are not acting as relay for data frame.

Names of LED	Indication contents of LED	LED status	Functional description
RELAY2	Display Relay operation status by port	ON	Ports 3 and 4 operate when the data frame operates as a relay.
		Off	This is the case when ports 3 and 4 are not acting as relay for data frame.
FAULT	Display FAULT LED operation state.	ON	This is when MRS has a station number or IP collision with another node.
		Flickering	- This is the case of a station number collision between the nodes other than MRS in the network. - This is when the switching loop path is detected in the MRS.
		Off	The station number collision situation has been resolved and it is operating normally.

### Notes

- (1) Relay is a function that connects data between ports. Relay between ports is possible, and RELAY1 and RELAY2 display relay status between 1,2 port and 3,4 port.
- (2) MRS receives an IP linked to the set station number. Please be careful not to cause IP conflicts when configuring the network.
- IP address assigned to MRS: 192.168.1.xx (xx: 100 + station number switch 1~99)

## 2.4 Specification of cable

### 2.4.1 Twisted pair cable

Cables are classified into two types according to the following standards.

Shield or not: 3 categories (UTP, FTP, STP), frequency band used: 7 categories (Cat.1~7)

(1) Cable type (Shield)

Classification	Detail	Usage
UTP(or U.UTP)	Unshielded high speed signal cable	Up to 200MHz Sound + information (data)+ Low-end video signal
FTP(or S.UTP)	Cable where only the cable core is shielded	Max. 100MHz Electromagnetic interfere (EMI) and electrical stabilization are considered. Sound + information (data) + low grade video signal
STP(or S.STP)	Double shielded cable,Pair individual shielding and cable core are shielded	Up to 500MHz Sound + information (data)+ video signal, Replacement of 75Ω coaxial cable

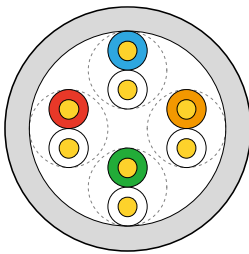

-UTP-

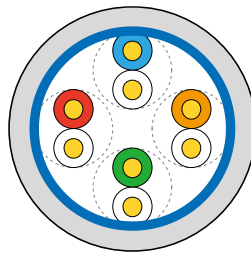

-FTP-

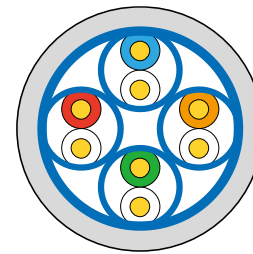

-STP-

**Notes**

UTP : Unshielded Twisted Paired Copper Cable

FTP : (Overall) Foiled Twisted Paired Copper Cable

STP : (Overall) Shielded(and Shielded Individually Pair)Twisted Paired Copper Cable

PLC Ethernet communication cable is recommended to use S.STP cable.

If the S.STP cable cannot be used due to the field conditions, a module error may occur due to communication error and noise.

(2) Cable categories

Classification	Applied frequency (MHz)	Transmission speed(M/Gbps)	Shield or not	Usage
Category 5	100	10/100M	Unshielded	100m 100BASE-TX is supported
Category 5e	100	100M/1G	Unshielded	1000BASE-Tsupported
Category 6	250	1G	Unshielded /Shielded	1000BASE-T supported
Category 6a	500	10G	Shielded	10G BASE-Tsupported
Category 7	600	10G	Shielded	10G BASE-Tsupported

Category 7a	1000	10G	Shielded	10G BASE-Tsupported
-------------	------	-----	----------	---------------------

(3) Example of category 5 twist pair wire (UTP) (CTP-LAN5)

Item	Unit		Value
Conductor resistance (Max.)	Ω/km		93.5
Insulation resistance(Min.)	MΩ·km		2500
Withstand voltage	V/minute		AC 500
Characteristic impedance	Ω(1~100MHz)		100 ± 15
Attenuation	dB/100m or less	10MHz	6.5
		16MHz	8.2
		20MHz	9.3
Near-end crosstalk attenuation	dB/100m or less	10MHz	47
		16MHz	44
		20MHz	42

### 2.4.2 Optical Fiber Cable

Item	Value
Cable type	MMF: Twin strands of Multi-mode fiber/SMF: Single-mode fiber
Connector	XGL-EFMF: SC type connector XGL-EFMFB/EFMHB: LC type connector

#### Notes

- (1) The connection cable of the communication module differs according to the system configuration and environment, so please consult with a specialist.
- (2) The characteristics of the optical cable are that when the fingerprint or contaminants are caught on the end of the cable, attenuation may occur and the communication may be interrupted.

## 2.5 How to connect communication between our products

Ethernet module displays communication connection method with own communication module when master and slave operate.

### 2.5.1 Master communication

Service items	Driver	Communication device	Ethernet module				EtherNet/IP	Smart I/O expansion		RAPIEnet V1		Other companies Device	Note	
			XGL-EFMxB V5.x	XGL-EFMxB V6.x	XGL-EFMxB V8.x	XBL-EMTA		XGL-EIPT	XEL-BSSA	XEL-BSSB	XGL-EIMT/FH			GEL-xxxx (V1.x version)
High-speed link	FEnet	X	O	O	O	O	X	X	X	X	X	X		
	RAPIEnet (V1)	X	O	O	X	X	X	X	O	X	X	X		
	RAPIEnet (V2)	X	X	O	X	X	X	X	X	X	X	X		
	RAPIEnet Remote (V1)	X	X	X	X	X	X	X	X	O	X	X	Communication to Smart I/O block RAPIEnet v1	
P2P	XGT Enet client	X	O	O	O	X	X	X	X	X	X	X		
	XGT Cnet client	X	O	O	O	X	X	X	X	X	X	X	Our Cnet module and communication	
Smart Extension	RAPIEnet client (V1)	X	O	O	O	X	X	X	X	X	X	X		
	RAPIEnet client (V2)	O	O	O	X	X	X	X	X	X	X	X		
	Modbus/TCP	O	O	O	O	X	O	X	X	X	X	△	Available when supporting Modbus / TCP on third	
	Modbus RTU/ASCII	X	O	O	O	X	X	X	X	X	X	X		
	User frame definition	X	O	O	O	O	X	X	X	X	X	△	Third party devices with protocol open	
	E-mail	X	X	X	X	X	X	X	X	X	X	X	Send message to mail address	
	-		O	X	X	X	O	X	O	X	X	X	△	Available when supporting EtherNet/IP on third party

2.5.2 Slave communication

Service items	Driver	Communication device	Ethernet module				EtherNet/IP	Smart I/O expansion		RAPIenet V1		Other companies Device	Note
			XGL-EFMxB V5.x	XGL-EFMxB V6.x	XGL-EFMxB V8.x	XBL-EMTA		XEL-BSSA	XEL-BSSB	XGL-EIMT/FH	GEL-xxxx (V1.x version)		
XGT server	-	X	O	O	O	O	X	X	X	X	X	X	
Modbus Server	-	X	O	O	O	O	X	X	X	X	X	△	Available when supporting Modbus / TCP on third
RAPIenet server	-	X	X	O	O	X	X	X	O	X	X	X	
Explicit message server, Adapter	-	X	X	O	X	O	O	X	X	X	△	△	Available when supporting EtherNet/IP on third party



## Chapter 3 Product Installation and trial operation

### 3.1 Product Installation

#### 3.1.1 Preparation for operating

##### (1) Ethernet module system configuration

- 1) Check the basic elements necessary for the system configuration and select a proper communication module.
- 2) Select a cable for the communication module.
- 3) When installing the Communication module, make sure that there is no foreign substance in the base connector to be mounted, and check that the connector pin of this module is not damaged.
- 4) Ethernet module can be mounted on the main base and expansion base, but it is recommended to use it on the main base. However, in case of XGR system, it can be installed only on the main base.
- 5) When installing the module, insert the raised part of the lower part of the module into the base groove without connecting the communication cable, and apply enough force until the upper part is completely locked with the base locking device. If it is not locked, there may be abnormality in the interface with the CPU module.
- 6) Cables used for communication module should be installed referring to the standard.
- 7) Ethernet switches and cables required for communication with the Ethernet module should be selected as standard products.

##### (2) Switch module system configuration

- 1) When installing the switch module, make sure that there is no foreign substance in the base connector to be mounted, and check that the connector pin of this module is not damaged.
- 2) XGL-EH5T module is powered from the base module. Therefore, the switch module is not recognized by the CPU and can be installed in either the expansion or the main base slot.
- 3) When installing the module, insert the raised part of the lower part of the module into the base groove without connecting the communication cable, and enough force until the upper part is completely locked with the base locking device. If the lock is not locked, the module may be detached from the base module.
- 4) The XOL-ES4T / ES4H Switch module should be fixed to the panel and supplied with a 24 VDC connector.

### 3.1.2 Setting sequence for operation

Describes the order of installation and operation of the product. When the installation of the product is completed, please install and set up the system in the following order.

- 1) Mount Ethernet module on base module.
- 2) Connect the cable of Ethernet module with other communication module.
- 3) Power on the system where Ethernet module has installed.
- 4) Setting basic parameter in XG5000.
- 5) Reset the module after downloading the basic parameters.
- 6) After resetting the module, Check if RUN and CHK LEDs are normal.
- 7) If Ethernet module and CPU module are confirmed as normal operation, check [System Diagnostics] → [PLC Information] using XG5000.
- 8) To check the network connection, check if the response is received from the PC to the network using PING, or if the network is not connected to the PC, select the Ethernet module on the monitor in [Online]→[Communication module setting and Diagnostics]→[System Diagnostics] of the XG5000 and then click the mouse. Check the response using the right-click Ping Test item.
- 9) Set up and download communication services.
- 10) Allow Service Enable.
- 11) Write a program in xG5000 and download it to CPU module to start operation.

#### Notes

(1) If the station number and IP address of the Ethernet module are set, be sure to Reset the module. Initial station number and IP address (including frame) keep the value read from communication module at initialization. Parameter changes during communication are not applied during operation.

3.2 Installation

3.2.1 Ethernet module

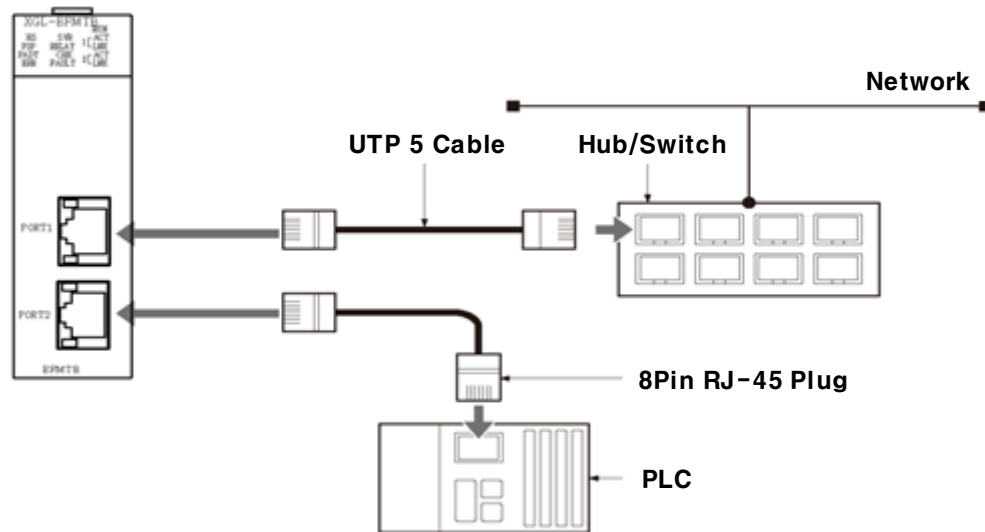

Maximum segment length for electric media is 100 m. Cables are classified into two types according to the following standards.

Pin No.	Signal	Between Switch and Ethernet module Straight cable	Cross cable
1	TD+	1 — 1	1 — 3
2	TD-	2 — 2	2 — 6
3	RD+	3 — 3	3 — 1
4	TRD2+	4 — 4	4 — 7
5	TRD2-	5 — 5	5 — 8
6	RD-	6 — 6	6 — 2
7	TRD3+	7 — 7	7 — 4
8	TRD3-	8 — 8	8 — 5

(1) Straight cable

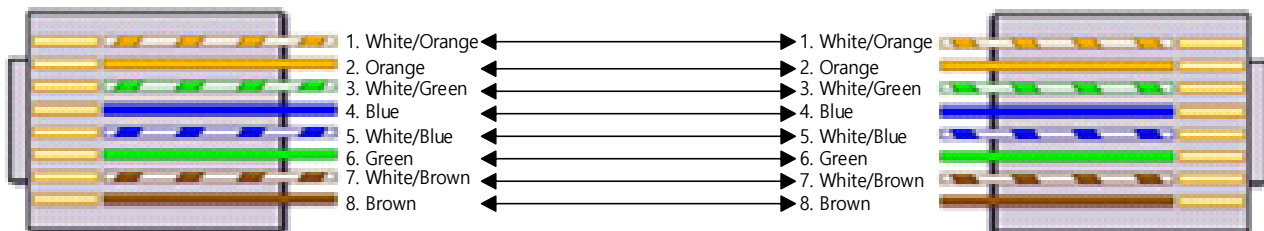

(2) Cross cable

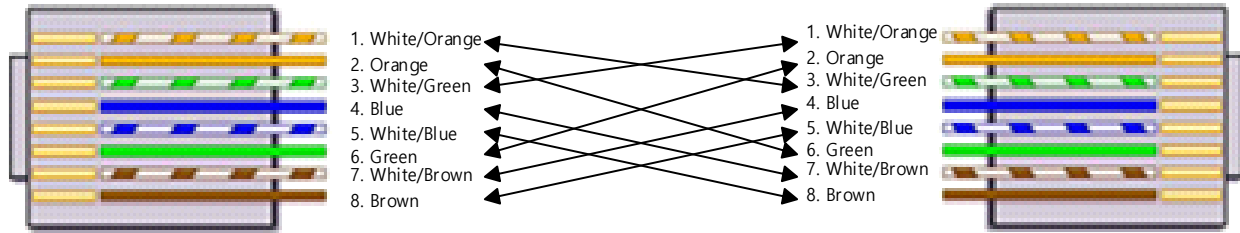

**Notes**

- (1) Twisted pair cable is manufactured by twisting wires of pins 1 - 2, 3 - 6, 4 - 5 and 7 - 8 to reduce interference between pairs.
- (2) Hub power should be separated from PLC power so that there is no noise effect.
- (3) For cable terminal processing and production, please consult with a professional manufacturer for production and installation.
- (4) When using STP cables, the shielded drain wire of the cable must be in electrical contact with the RJ45 shields on both sides.
- (5) The optical cable is susceptible to impact, pressure, folding, pulling, etc.  
If the cable contact surface connected to the connector is contaminated, communication failure may occur or communication may not be possible. Therefore If you are installing outdoors, you need additional cable protection measures appropriate for your installation environment.
- (6) Module connector type of XGL-EFMF (SC type) and XGL-EFMFB (LC type) are different.  
In case of mixed use, use SC-LC converter to connect.

(3) Precautions for installing the cable

- 1) For reliable 100Mbps signal transmission, use a cable that meets category 5 or higher characteristics.
- 2) Be careful not to exceed excessively the tensile strength of the cable while wiring.
- 3) When removing the cover, peel off the cover only for the length you want to wire and make sure that the insulation is not damaged.
- 4) The cable connector should be slightly loosened. If you connect too strongly, the characteristics of Category - 5 may be deteriorated.
- 5) Maintain proper distance between EMI sources and cables when installing cables.

Condition	Minimum separation distance		
	2.0KVA or less	2.5 KVA	5.0KVA or higher
Unshielded power line or electrical equipment are open or in close proximity to non-metallic pipes	127mm	305mm	610mm
If the unshielded power line or the electric equipment is close to a buried metallic pipe	64mm	152mm	305mm
If the power line in the buried metallic pipe (or equivalent shielded metallic pipe) is close to a buried metallic pipe	-	76mm	152mm
Transformer, electric motor and fluorescent light	1,016mm , 305mm		

**Notes**

- (1) When the voltage is 480V and the power rating is 5KVA or more, additional calculation is required.

### 3.2.2 Installing and Removing the Switch Module

The XOL-ES4T / ES4H is equipped with a standard DIN rail (35 mm rail width) hook and can be installed on the DIN rail. When installing on DIN rail

- ① The can be installed directly on the panel using screw mounting holes.
- ② The can be installed directly on the panel using screw mounting holes.

\* The DIN rail stopper must be installed on both sides of the module to secure the module.

In case of installing at panel

- ① The can be installed directly on the panel using screw mounting holes.
- ② When installing the product directly to the panel, use M3 type fixing screws.

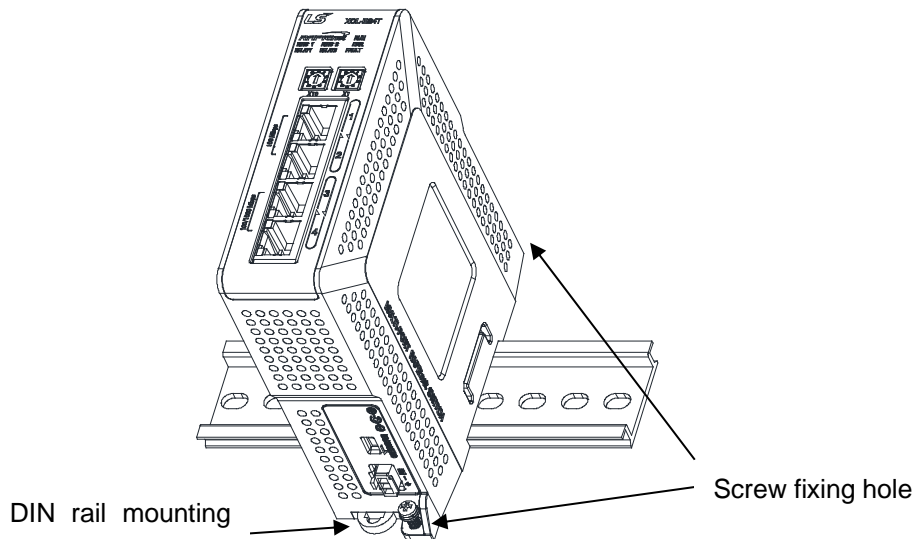

### Precautions for Ethernet Switch Module(XGL-EH5T) Installation

Switch modules can be used to connect between Ethernet modules using 10 / 100BASE-TX. Therefore, as shown in the figure below, the configuration for network system configuration between modules and between PLC systems and PCs can be connected.

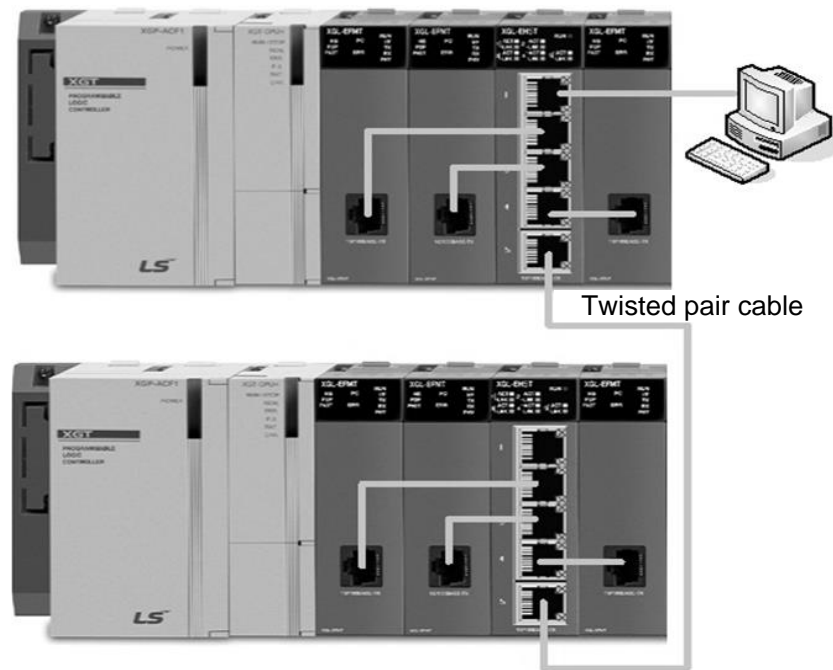

### 3.3 Test operation

After connecting the communication cable, turn on the power and check the LED for normal operation. If it is normal, download the program to the PLC and execute the program.

#### 3.3.1 Precautions for System Configuration

IP addresses, including Ethernet modules, must not overlap each other. If duplicate address is connected, it does not work due to communication error. In addition, the high speed link station number must be different to use the high speed link service. Use a cable of the specified standard for the communication cable. Unspecified cables can cause serious communication problems. The communication cable should be checked for disconnection or short circuiting before installation. Securely connect the communication cable connector. Incomplete cable connection may cause communication error.

When connecting communication cables over long distances, route the cables at a sufficient distance from the power line or inductive noise. If the cable is bent at a right angle or is excessively deformed, it may cause cable breakage and damage to the connector in the communication module. If the LED does not work normally, refer to 'Chapter 9 Troubleshooting' in this manual to check the cause of the problem and if the problem still occurs, please contact the customer service center.

#### 3.3.2 Check items before trial operation

This section describes the items to check before trial operation.

##### (1) Communication module mounted on PLC

Verification	Content
Software installation and check	- Installing XG5000?
Communication cable connection (if the cable is connected)	- Is communication cable connection and tap in good condition? - Is module LED and cable properly connected?
Module mounting	Is the communication module mounted on the main base module correctly?

(2) Sequence of trial operation

The following shows the procedure from the completion of installation on the PLC to the trial run.

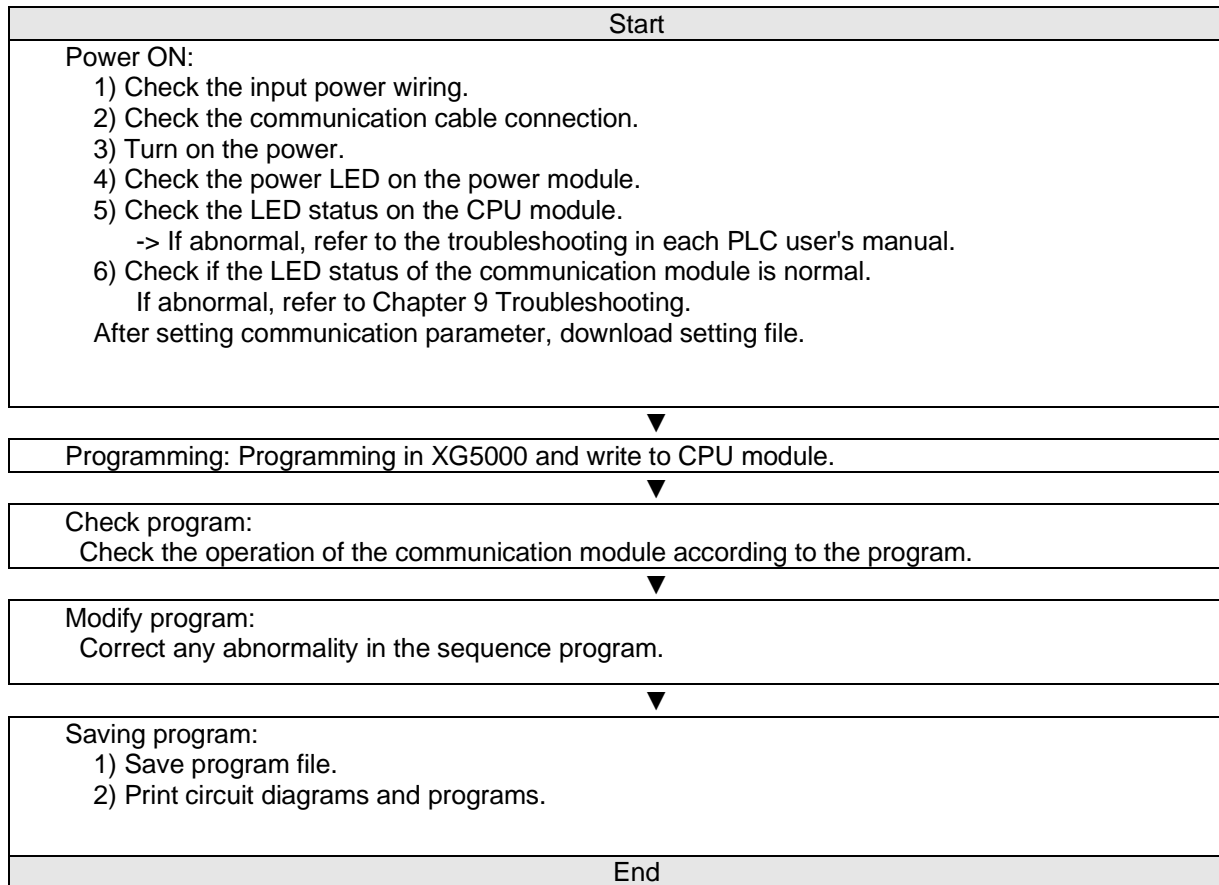

### 3.3.3 The method to remove and replace the module.

If you want to replace or remove the module due to hardware error or system change, follow the procedure below.

(1) Order of exchanging communication module

- 1) Turn off the power module of the base where the communication module is installed.
- 2) Disconnect the network cable.
- 3) Operate the module according to the setting procedure in Section 3.3.2.

(2) Communication module exchange using the module change switch of the CPU.

Refer to “6.10 Changing Module during Operation” of CPU Module User's Manual.

(3) Communication module exchange using x5000 module change wizard

Refer to “10.23 Module Change Wizard” of XG5000 user's manual.

#### Notes

- (1) When replacing the Ethernet module, reset the external device (MMI or PC). The timeout of the Ethernet module may result in an unrequested connection from the external device or a loss of communication.

3.4 Precautions when Connecting to a Network

If a node that supports the RAPIEnet protocol and a node that does not support the RAPIEnet protocol are connected on the same network, refer to the information below.

3.4.1 Use ring network

When using a ring network, the node that supports the RAPIEnet protocol selects the ring manager for ring control. At this time, because Relay option is disabled, nodes that do not support RAPIEnet protocol connected to Ring Manager cannot communicate with other nodes except Ring Manager. (Relay operation is not performed even if Relay option of Ring Manager is Enable.)

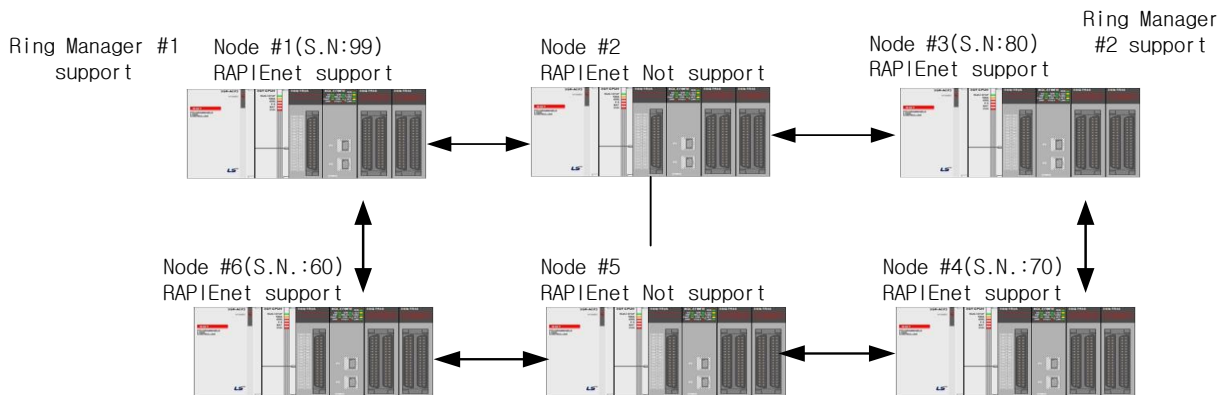

RAPIEnet Unsupported Node	Communication					
	Node #1	Node #2	Node #3	Node #4	Node #5	Node #6
Node #2	Possible	-	Possible	Impossible	Impossible	Impossible
Node #5	Possible	Impossible	Possible	Possible	-	Possible

Notes

When configuring a ring network, the standards for selecting a ring manager are as follows. (See picture above)

- (1) The node with the highest station number among the RAPIEnet support nodes is selected as Ring Manager # 1.
- (2) Among the neighbouring RAPIEnet supporting nodes of the node selected as Ring Manager # 1, the node with the highest station number is selected as Ring Manager # 2. (# 3, the highest station number among nodes # 3 and # 6, is selected.)
- (3) Ring Manager # 1 and # 2 do not Relay.

3.4.2 Use line network

When using a line type network, both last nodes among the nodes that support the RAPIEnet protocol are selected as the Line Manager. At this time, if you connect nodes that do not support the RAPIEnet protocol to the outside of the line managers, the nodes that can communicate with the nodes are determined by the relay option of the line manager.

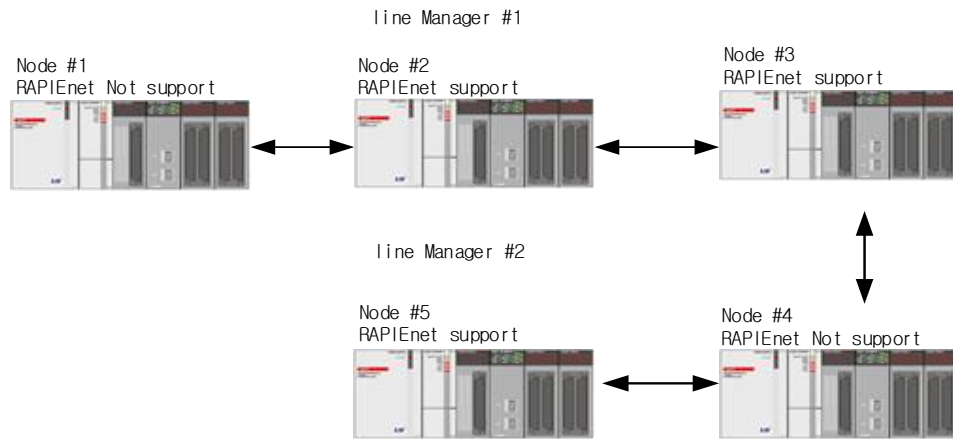

RAPIEnet Unsupported Node	Node #2 Relay option	Communication				
		Node #1	Node #2	Node #3	Node #4	Node #5
Node #1	Enable	-	Possible	Possible	Possible	Possible
	Disable	-	Possible	Impossible	Impossible	Impossible
Node #4	Enable	Possible	Possible	Possible	-	Possible
	Disable	Impossible	Possible	Possible	-	Possible

### 3.5 XG5000 Program

XG5000 is a program tool for Ethernet communication network control and management. It provides configuration and management functions related to communication module such as communication parameter, communication service parameter and module and network diagnosis.

The functions related to Ethernet module of XG5000 can be classified as follows.

- 1) Standard settings
- 2) Communication service (high speed link, dedicated service, P2P) parameter settings
- 3) Module and network diagnostic services

The parameters and files set by the user can be written (downloaded) and read (uploaded) to the Ethernet communication module via the CPU module. The downloaded communication parameters are saved in the CPU and can be used without resetting even if the new communication module is replaced in the slot initially set.

#### Notes

1. Parameters stored in CPU: communication module basic parameters, P2P parameters, high-speed link parameters
2. Parameters stored in the Ethernet module: smart expansion parameters, EIP/OPC UA tag, certificate  
-> In case of item 2, a download is required when replacing the Ethernet module.

This chapter focuses on the settings required when using the Ethernet module.

#### 3.5.1 CPU type setting

To connect with PLC by XG5000, CPU type should be set first. On the XG5000, select [Project] → [New Project] to create a new project. In the New Project window, enter the name of the project as shown below, and select the CPU series and CPU type.

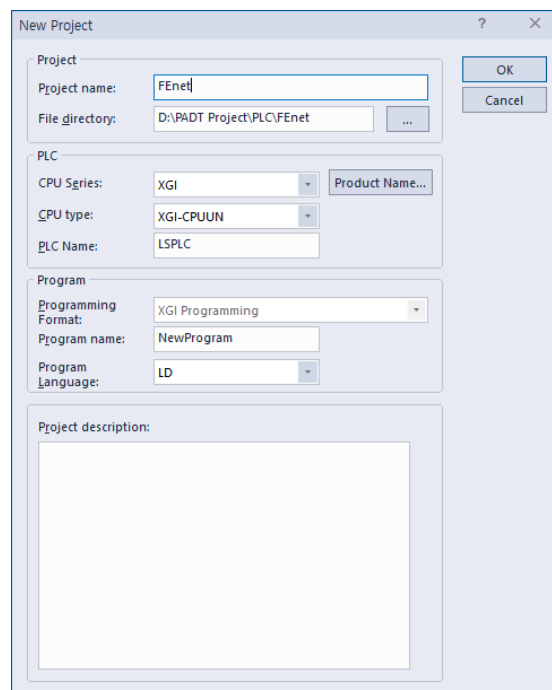

Press “OK” button to display the screen below.

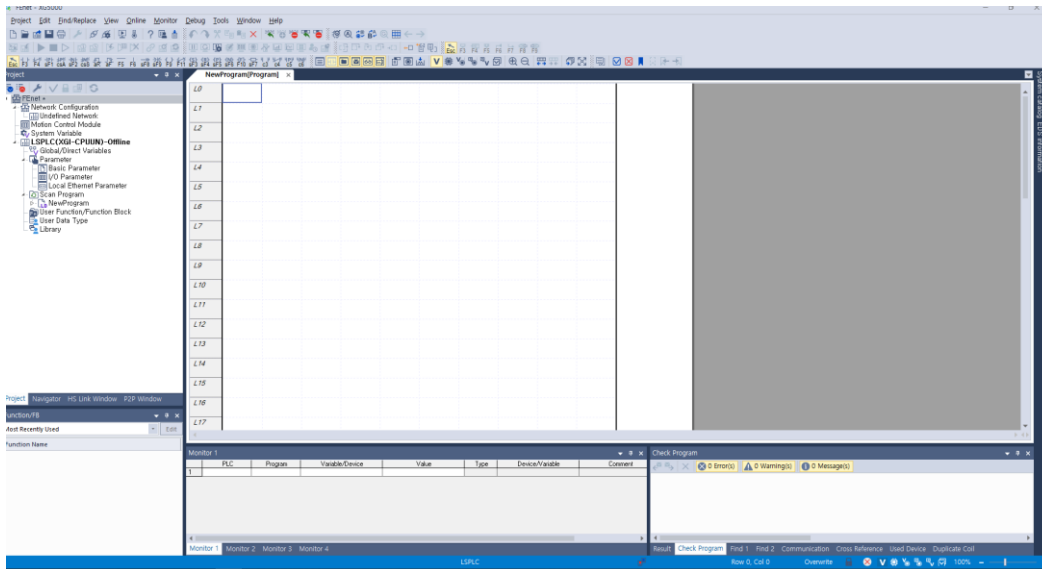

### 3.5.2 Communication module registration

This section describes the communication settings for the Ethernet module to operate.

#### (1) Selection and execution of communication module

For standard setting of communication module, base, slot location of communication module should be registered in Undefined Network of XG5000 project tree list.

##### 1) Offline registration

To register communication module without accessing XGT CPU module, use [Communication Module Settings] window. When registering Ethernet module in base 0 and slot 0, set as follows in the project window. In the Project window, select [Undefined Network], click the right mouse button and select [Add item]→[Communication module].

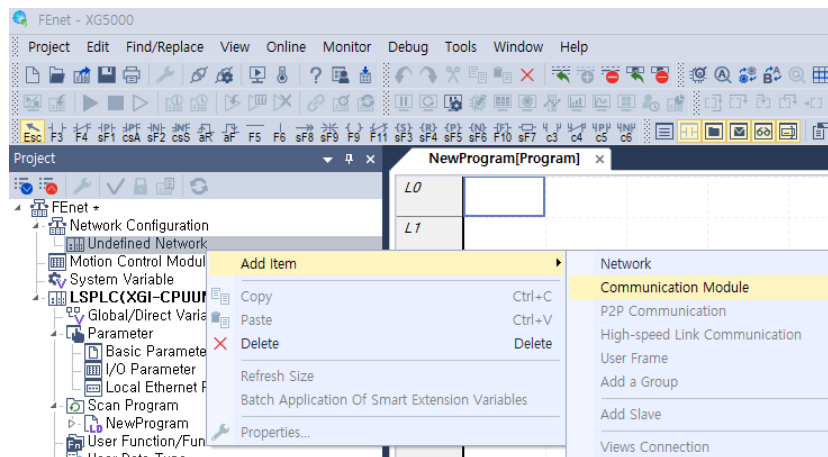

Click the [Add Module] button on the bottom left of the [Select Module] window.

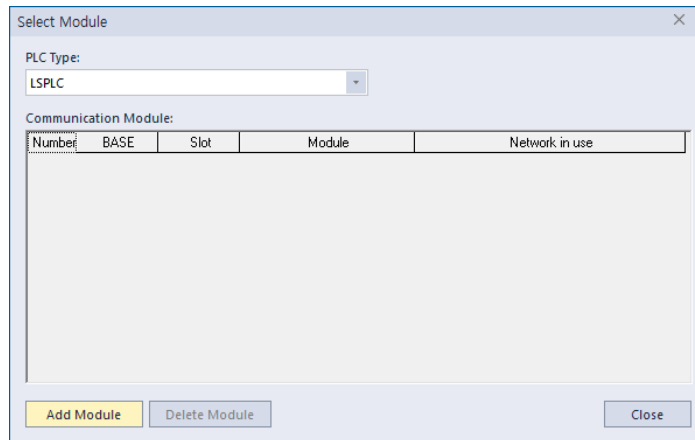

In the [Communication Module Settings] window, specify Type, Base and Slot.

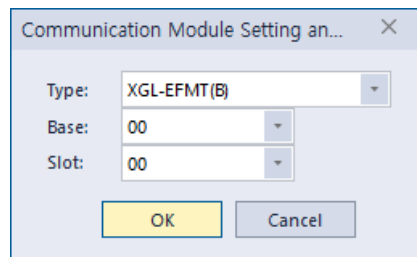

The screen where Ethernet module is registered in Slot 0 of BASE 0 is as follows.

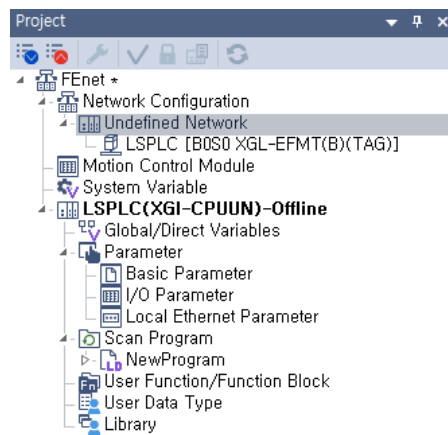

## 2) On line registration

If communication module is connected to the installed XGT CPU module, all communication modules installed in XGT can be searched automatically and registered in the project window as follows. However, online registration is possible only when the PLC mode is 'Stop'.

- a) Select [Online] → [System Diagnostics] → [I/O information] .

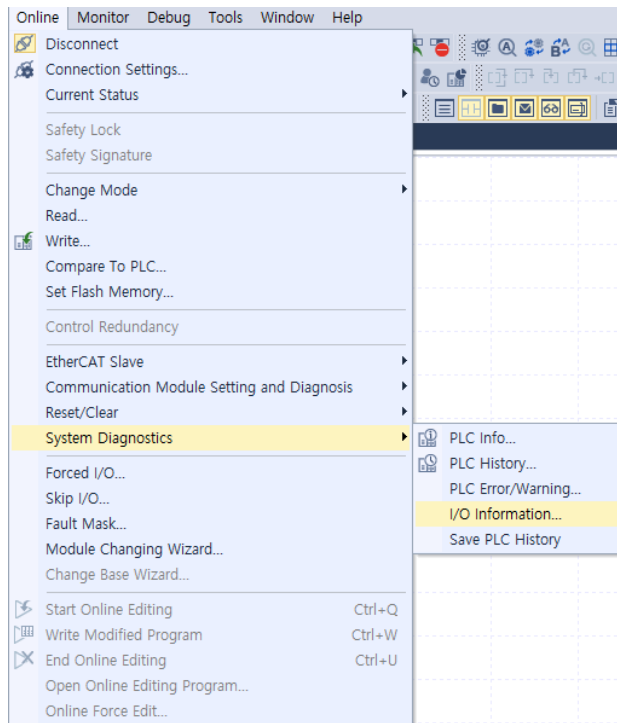

b) Press the "I/O Sync" button at the bottom left of the [I / O Information] window.

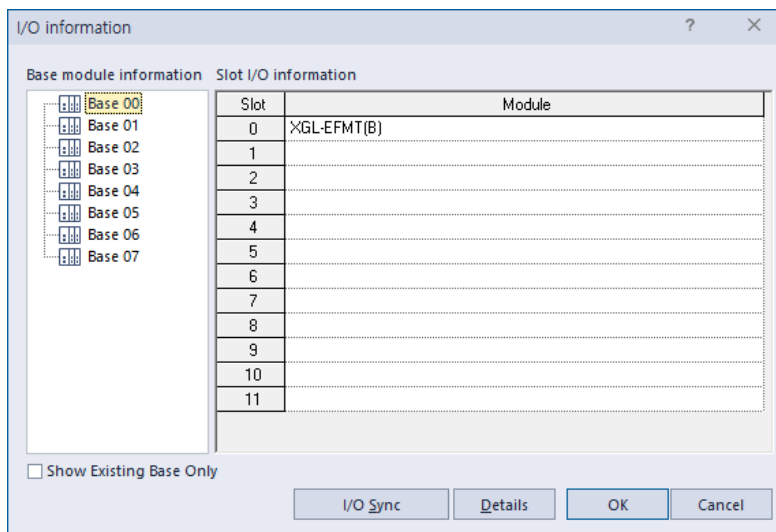

- c) Check the contents of the message window and click “Yes” if there is no problem.

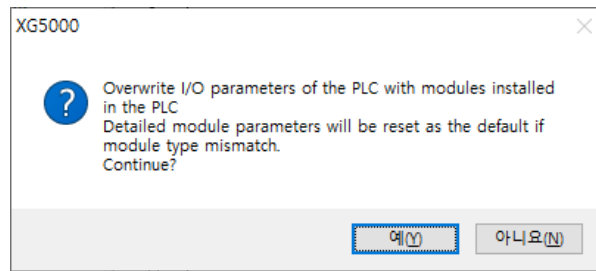

- d) The screen where Ethernet module is automatic registered in slot 00 of base 00 is as follows.

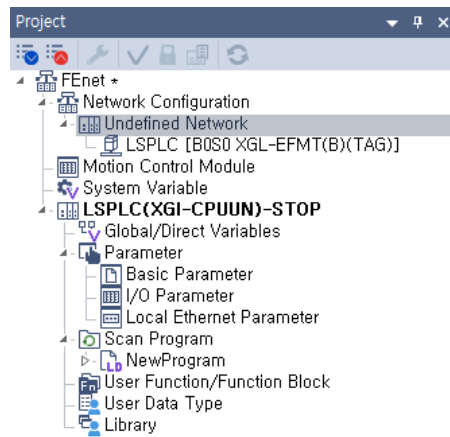

### 3.5.3 Basic settings

This is a screen for setting communication system parameters for Ethernet module to connect to network. It provides basic information such as IP address, Subnet Mask, Gateway address, Receive Time Out Setting, No. of Dedicated Connections, Host Table Settings and Sets EIP Server. Therefore, in order to perform Ethernet communication, it is necessary to download after setting the parameters in the Standard settings of the module. XGI / XGK and XGR Standard Settings screens are different.

(1) In case of CPU of XGK / XGI series

If you double-click Ethernet module under Undefined Network registered in project window, the following screen is created.

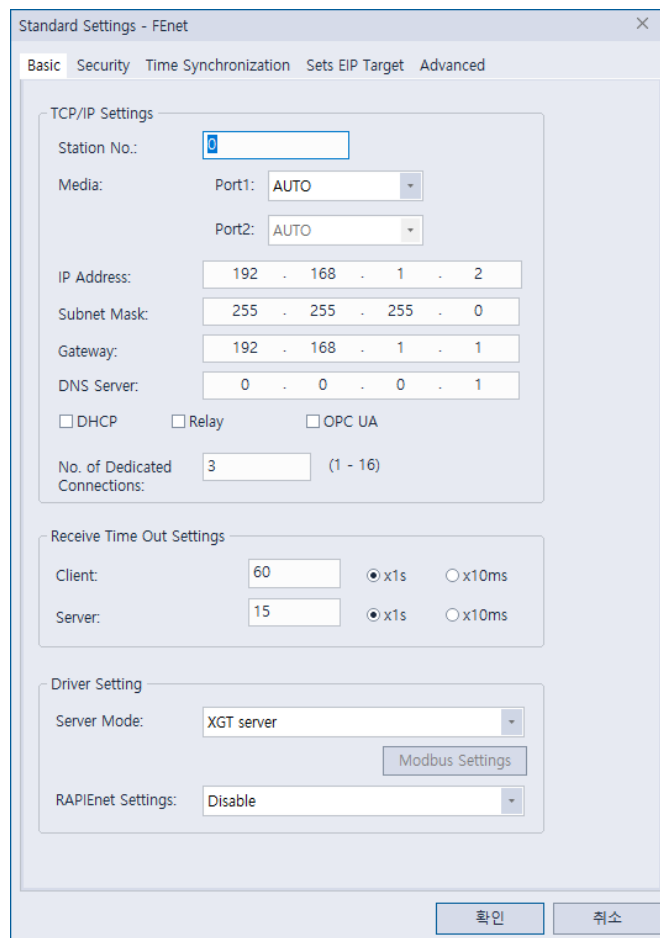

Standard Settings - FENet

Basic Security Time Synchronization Sets EIP Target Advanced

TCP/IP Settings

Station No.: 0

Media: Port1: AUTO Port2: AUTO

IP Address: 192 . 168 . 1 . 2

Subnet Mask: 255 . 255 . 255 . 0

Gateway: 192 . 168 . 1 . 1

DNS Server: 0 . 0 . 0 . 1

DHCP  Relay  OPC UA

No. of Dedicated Connections: 3 (1 - 16)

Receive Time Out Settings

Client: 60  x1s  x10ms

Server: 15  x1s  x10ms

Driver Setting

Server Mode: XGT server Modbus Settings

RAPiEnet Settings: Disable

확인 취소

The items in the Standard Settings window are as follows.

1) TCP/IP setting(XGK/I CPU series)

Classification	Content
Station No	<p>Station number used for high speed link and RAPIEnet communication between Ethernet modules.</p> <ul style="list-style-type: none"> <li>- Modules on the same network should not have duplicate station numbers.</li> <li>- The station number range of the high speed link communication is 0 ~ 63.</li> <li>- The station number range of the RAPIEnet communication (including Smart Extension) is 0 ~ 220.</li> </ul> <p>* Precautions for V6.0 and later</p> <ul style="list-style-type: none"> <li>- When RAPIEnet is enabled, it is set as RAPIEnet's station number.</li> <li>- When using Modbus RTU / ASCII and XGT Cnet server service, it is set as station number.</li> </ul>
Media	<p>Select the communication media you want to use.</p> <ul style="list-style-type: none"> <li>▷AUTO (electric): Automatically sets the media settings of the currently installed module.</li> <li>▷10M HALF: 10Mbps Half Duplex Electric</li> <li>▷10M FULL: 10Mbps Full Duplex Electric</li> <li>▷100M HALF: 100Mbps Half Duplex Electric</li> <li>▷100M FULL: 10Mbps Full Duplex Electric</li> <li>▷100M FX/HALF: 100Mbps Half Duplex optical</li> <li>▷100M FX/FULL: 100Mbps Full Duplex optical</li> <li>▷1G FULL: 1Gbps Full Duplex Electric</li> <li>▷1G FX/FULL: 1Gbps Full Duplex optical</li> </ul>
IP address	Set the IP address of the Ethernet module.
Subnet mask	This is the value for classifying whether the destination station is in the same network with its own station or not.
Gateway	Set the gateway module address (router address) for sending and receiving data through a station or a public network that uses a different network from your own station.
DNS server	Specifies the domain name server.
DHCP	DHCP (Dynamic Host Configuration Protocol) is used when you want to use dynamic IP (use when connecting ADSL line) without using Fixed IP.
Relay	Used to send data frames received on the port to the other port.
OPC UA	Enable / Disable the OPC UA server function.(Only V7.x version is supported)
No. of Dedicated Connections	<p>The maximum number of TCP-dedicated services that can be connected at the same time.</p> <ul style="list-style-type: none"> <li>- V6.0 or less version: Available range is 1~ 16 and default is 3.</li> <li>- V6.0 or higher version: The number of server connections that can be connected simultaneously is 64, and is not affected by the number of dedicated connections in the basic parameters.</li> </ul>

2) Reception timeout time setting

Classification	Content
Client	<p>If a response message is not received within the client Receive Time Out period set by the requesting server during P2P client communication, it assumes a problem with the server system and terminates the connected P2P client service.</p> <ul style="list-style-type: none"> <li>- V6.0 or less version: Not Available</li> <li>- V6.0 or higher 2 sec~255 sec setting available. (If the client driver type is RAPIEnet, 4 seconds are applied.</li> </ul>
Server	<p>If there is no request for the set time from the client while the server service is connected to the PC or HMI, the server operation is finished assuming that a problem has occurred with the client system.</p>

1) Driver setting

Classification	Content
Server mode	<p>XGT server: When operating as a server(TCP Port:2004, UDP Port:2005)</p> <ul style="list-style-type: none"> <li>- V6.0 or less: It supports XGT Enet dedicated communication server.</li> <li>- V6.0 or higher: Supports XGT Enet dedicated communication server / XGT Cnet dedicated communication server.</li> </ul> <p>Modbus server: Modbus server settings(TCP Port:502)</p> <ul style="list-style-type: none"> <li>- v6.0 or less: Supports Modbus TCP server</li> <li>- v6.0 or higher: Supports Modbus TCP / RTU/ASCII server</li> </ul> <p>Smart server: The XGT server and the Modbus server are supported at the same time. (V6.0 or higher)</p>
RAPIEnet setting	<p>Select the protocol driver when RAPIEnet is used.</p> <ul style="list-style-type: none"> <li>- Disable: RAPIEnet is not used.</li> <li>- RAPIEnet v1: Available from V6.0 or higher</li> <li>- RAPIEnet v2(Default): Available from V8.0 or higher</li> </ul>

(2) In case of XGR CPU

Indicates the default parameters set in the XGR CPU In the case of XGR, the Standard Settings varies depending on whether the One IP Solution function is used or not.

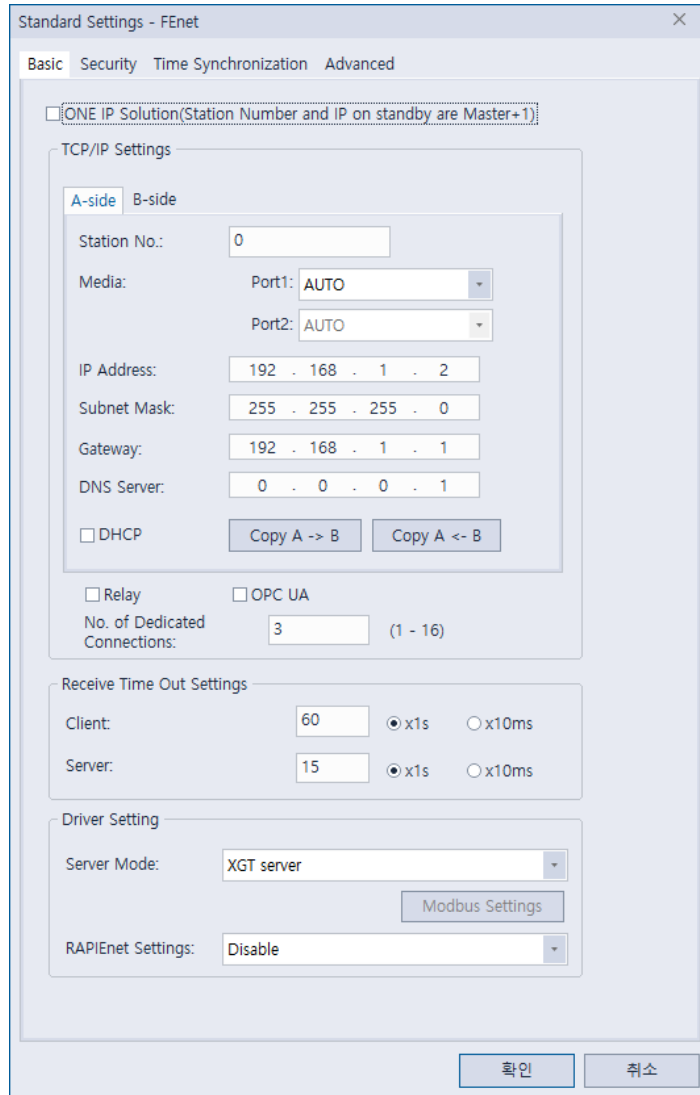

1) ONE IP Solution

If ONE IP Solution is used, when master switching occurs due to error, communication disconnection, etc., the IP address of the FENet module mounted on the master base and the FENet module mounted on the standby base are exchanged. To do this, an individual module reset is performed after the master switch.

- If you check ONE IP Solution, ONE IP Solution is activated and only one IP is registered.
- When using ONE IP Solution, only an even number can be entered. The configured IP address becomes the Ethernet module IP address of the master base.
- The Standby base Ethernet module IP address becomes Master base Ethernet module IP address + 1.

2) TCP/IP setting(XGR CPU series)

After setting one of A-side or B-side, use copy button or set station number and IP independently.

Classification	Content
Station No	Station number used for high speed link and RAPIEnet communication between Ethernet modules. - Modules on the same network should not have duplicate station numbers. - The station number range of the high speed link communication is 0 ~ 63. - The station number range of the RAPIEnet communication (including Smart Extension) is 0 ~ 220. * Precautions for V6.0 or higher - When RAPIEnet is enabled, it is set as RAPIEnet's station number. - When using Modbus RTU / ASCII and XGT Cnet client, it is set as station number.
Media	Select the communication media you want to use. ▷AUTO (electric): Automatically sets the media settings of the currently installed module. ▷10M HALF: 10Mbps Half Duplex Electric ▷10M FULL: 10Mbps Full Duplex Electric ▷100M HALF: 100Mbps Half Duplex Electric ▷100M FULL: 10Mbps Full Duplex Electric ▷100M FX/HALF: 100Mbps Half Duplex optical ▷100M FX/FULL: 100Mbps Full Duplex optical ▷1G FULL: 1Gbps Full Duplex Electric ▷1G FX/FULL: 1Gbps Full Duplex optical
IP address	Set the IP address of the Ethernet module.
Subnet mask	This is the value for classifying whether the destination station is in the same network with its own station or not.
Gateway	Set the gateway module address (router address) for sending and receiving data through a station or a public network that uses a different network from your own station.
DNS server	Specifies the domain name server.
DHCP	DHCP (Dynamic Host Configuration Protocol) is used when you want to use dynamic IP (use when connecting ADSL line) without using Fixed IP.
Copy A -> B, Copy B -> A	It is activated when One IP Solution is not checked. After setting Standard Settings parameters of A side or B side, click A-> B Copy or B-> A to copy the set parameters to the other side.
Relay	Used to send data frames received on the port to the other port.
OPC UA	Enable / Disable the OPC UA server function.(Only V7.x version is supported)
No. of Dedicated Connections	The maximum number of TCP-dedicated services that can be connected at the same time. - V6.0 or less version: Available range is 1~ 16 and default is 3. - V6.0 or higher version: The number of server connections that can be connected simultaneously is 64, and is not affected by the number of dedicated connections in the basic parameters.

3) Reception timeout time setting

Classification	Content
Client	If a response message is not received within the client Receive Time Out period set by the requesting server during P2P client communication, it assumes a problem with the server system and terminates the connected P2P client service. - V6.0 or less version: Not Available - V6.0 or higher: 2 sec~255 sec setting available (If the client driver type is RAPIEnet, 4 seconds are applied).
Server	If there is no request for the set time from the client while the server service is connected to the PC or HMI, the server operation is finished assuming that a problem has occurred with the client system.

4) Driver setting

Classification	Content
Server mode	XGT server: When operating as a server(TCP Port:2004, UDP Port:2005) - V6.0 or less: It supports XGT Enet dedicated communication server. - V6.0 or higher: Supports XGT Enet dedicated communication server / XGT Cnet dedicated communication server Modbus server: Modbus server settings(TCP Port:502) - v6.0 or less: Supports Modbus TCP server - v6.0 or higher: Supports Modbus TCP / RTU/ASCII server Smart server: Simultaneous supports XGT server and Modbus server (V6.0 or higher).
RAPIEnet setting	Select the protocol driver when RAPIEnet is used. - Disable: RAPIEnet is not used. - RAPIEnet v1: Available from V6.0 or higher - RAPIEnet v2(Default): Available from V8.0 or higher

Notes

1. In the media setting, all items except "AUTO" are Force mode. The link setting may be wrong when connecting between AUTO set device and Force mode set device, so XGL-EFMxB (V8.1 or higher) and XOL-ES4x (V2.1 or higher) products do not support the above link setting. In order to use it in force mode, the link partner must be set to the same force mode and the connecting cable must use a cross cable.

◆ Media setting example

Case	Device A Media setting	Device B Media setting	Result
1	AUTO	AUTO	Link up available
2	AUTO	α Force mode	Link up Unavailable
3	α Force mode	α Force mode	Link up available
4	α Force mode	β Force mode	Link up Unavailable

2. For XOL-ES4x products, the media setting is always "AUTO"

### Notes

- (1) In case of DHCP setting, download the parameter and connect to PLC and check the IP address in [Online]→ [Communication module setting]→[System diagnosis]→[Communication module information]. In addition, you can check the default setting displayed when you double-click the communication module displayed in the project tree after opening from the PLC.
- (2) For a dynamic IP address, if the power is off, the existing IP address may not exist.
- (3) When making remote connection to the module with DHCP setting If the power of the remote side is turned on again as in (2), check the IP address for the remote station again.
- (4) Refer to the table below for the PORT information for IP allocation using DHCP by OS version of XGL-EFMxB.

OS Version	XGL-EFMTB	XGL-EFMFB	XGL-EFMHB
8.30 or less	PORT 1	PORT 1	PORT 2
8.30 or higher	PORT 1.2	PORT 1.2	PORT 1.2

### Notes

1. If you are not using RAPIenet, please set RAPIenet to Disable
2. When setting RAPIenet, check the protocol driver that can be supported by OS version and set it.

3.5.4 Security setting

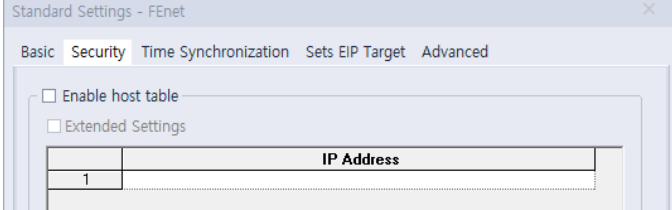
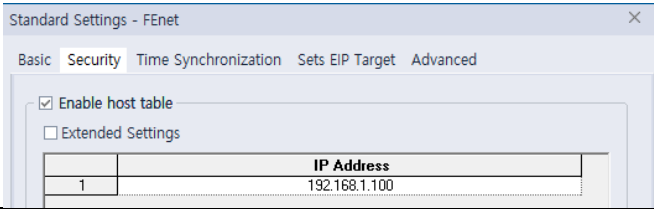
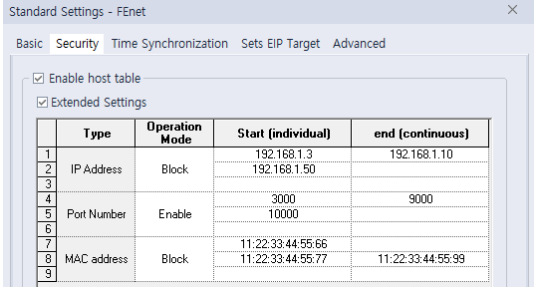
Case	Classification	Setting availability	Set or not
1	Enable host table	No Setting	There are no restrictions on the devices accessed by the module. 
2	Enable host table	Setting	Only the devices with the IP address registered in the host table is allowed. 
	Extended parameter	No Setting	
3	Enable host table	Setting	Set access permission and access denial with parameters of MacAddress, IP Address, and TCP/UDP Port Number. Individual, range, and Wildcard settings are possible. 
	Extended parameter	Setting	

User custom port: This is a function to change the server port. By default, the XG5000 port is assigned 2002, the XGT server (TCP) is assigned 2004, and the XGT server (UDP) is assigned 2005, but you can change this value to the number you want.

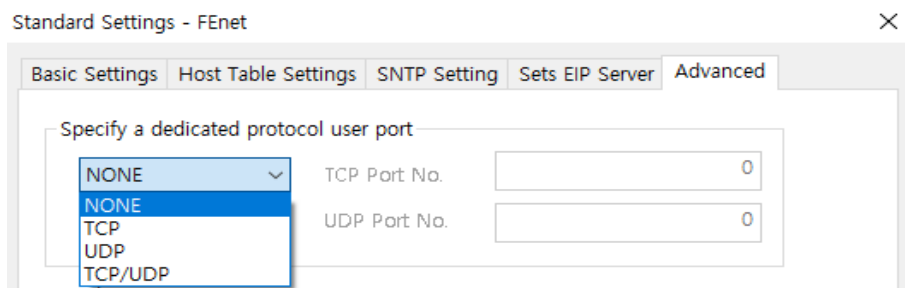

[XG5000 V4.5x UI]

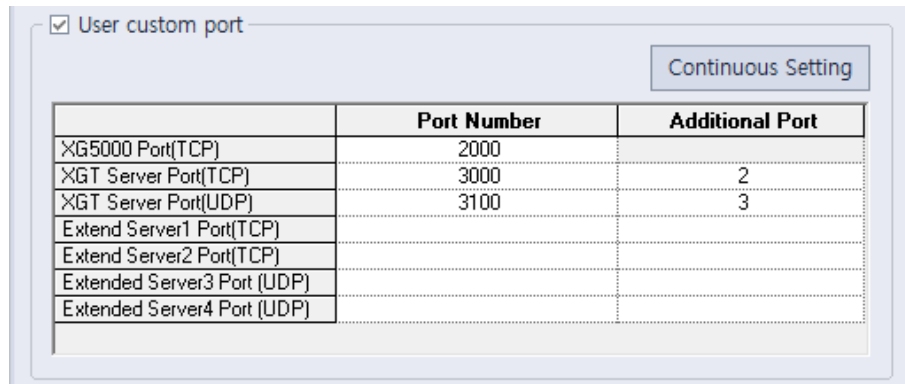

[XG5000 V4.61 or higher UI]

The number of channels allocated on a user port is different for each OS version, see the table below.

OS version of FEnet module	Compatible XG5000 versions	User port number setting	Number of channels (Default port number)	Number of channels (User port number)
V6.0 or less	-	Do not support user port setting function	Setting the number of dedicated connections and server mode in basic parameters	-
V6.0 ~ V8.0	-	Do not support user port setting function	XGT server: 64 Modbus server: 64	-
V8.10 ~ V8.20	V4.50~V4.60	When not setting user port number	XGT server: 64 Modbus server: 64	-
		When setting user port number	Modbus server: 64	XGT server: 64
V8.30 ~V8.55	V4.50~V4.60	When not setting user port number	XGT server: 64 Modbus server: 64	-
		When setting user port number	XGT server: 56 Modbus server: 64	XGT server: 8
V8.60 or higher <sup>note1)</sup>	V4.61 or above	When not setting user port number	XGT server: 64 Modbus server: 64	-
		When setting user port number	XGT server: 32 Modbus server: 64	XGT server: 32 <sup>note2)</sup>

Note 1) If the FEnet module OS version is V8.60 or higher, the user port function has changed and is not compatible with lower versions. Please use XG5000 V4.61 or higher version.

Note 2) When setting [Number of additional ports], N consecutive numbers starting from the port number set can be used as user ports. The number of channels for each additional port is allocated by dividing 32 into N+1.

Example) When setting port number 3000 and number of additional ports to 3:

User-defined ports 3000~3003, number of channels for each port:  $32/(3+1) = 8$  channels

## 3.5.5 Time synchronization Setting

This is the SNTP (Simple Network Time Protocol) protocol setting screen that synchronizes time with the server by requesting time information from an NTP (Network Time Protocol) server.

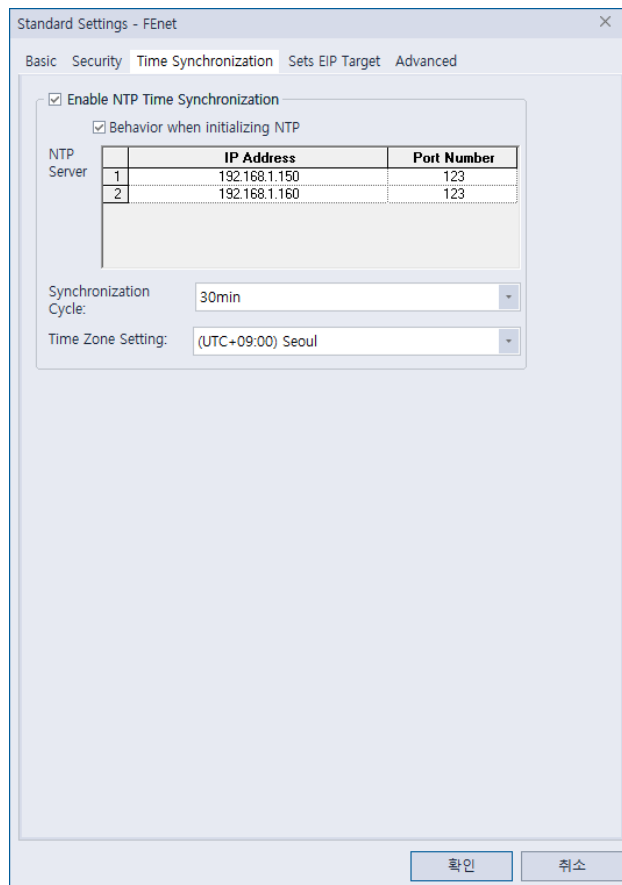

Classification	Content
Enable SNTP Time Synchronization	ENABLE : Enable SNTP operation DISABLE : Disabled SNTP operation
Behavior when initializing SNTP	ENABLE: Operates immediately when power is applied. DISABLE: Operates after synchronization cycle time after power is applied.
NTP server	Register NTP server to request time information.
Synchronization cycle	Set the frequency to request time information.
TIME ZONE Setting	Set the standard time.

### Notes

- (1) When SNTP is activated, the module receives the time received from the NTP server and updates it with the CPU time information.
- (2) When SNTP is activated after installing multiple Ethernet modules, each Ethernet module individually transmits the time received from the NTP server to the CPU.

### 3.5.6 EIP Target Setting

This is a screen to input local tag and data count when using EtherNet / IP target.

Classification	Content
Local tag	Set the tag to use as EIP target among the registered local tags. - It can be set as target tag of 'Device / Variable' in addition to local tag.
The number of data	When you enter a local tag, the data count of the selected tag is displayed.

### 3.5.7 Advanced Settings

Media: This function limits the maximum connection speed to 100Mbps when media in Basic Settings is set to AUTO.

Media

Limit auto negotiation speed to 100Mbps

### 3.5.8 Download/Upload

Standard Settings parameters created using XG5000 can be written (download) or parameters can be read (uploaded).

#### (1) Writing (download)

1) Connect with the CPU of the system equipped with the Ethernet module via [Online] → [Connect].

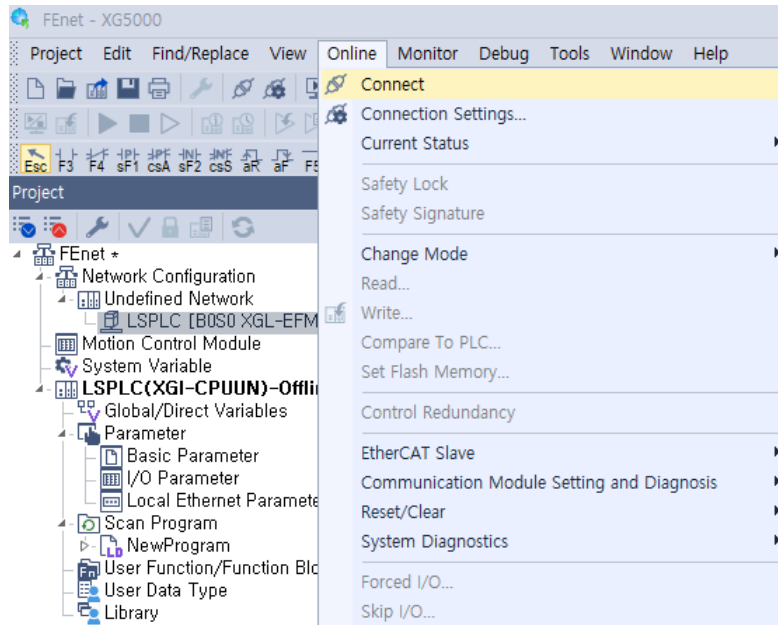

2) Select [Online] → [Write].

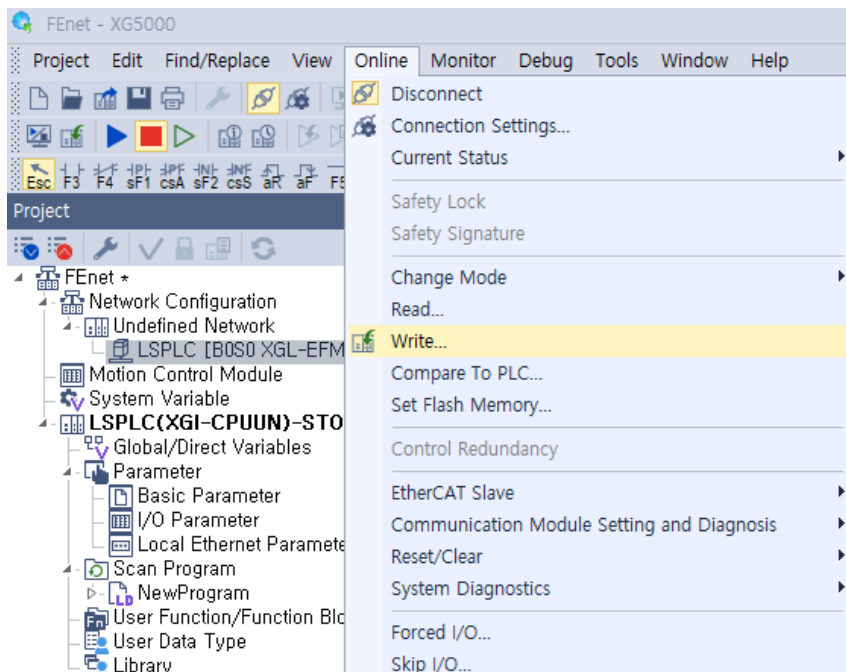

3) After selecting the network parameter to download and pressing “OK” button, writing is completed and PLC reset is executed.

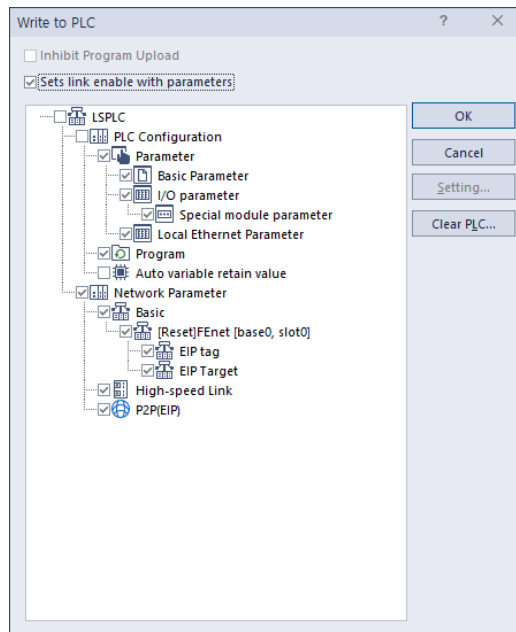

**Notes**

- 1) XG5000 can be connected to RS-232C port or USB port of CPU module. Refer to the wiring diagram of the relevant CPU module for the available cable types.
- 2) When downloading the communication parameters to the CPU module, if the link of the related service is allowed, the parameter is automatically changed after the download is completed. If the link of the related service is not allowed, the parameter is not applied until the link is allowed.
- 3) When writing after changing basic setting in V6.0 or higher version, the CPU module must be reset after writing to apply the changed contents to communication module.

### (2) Reading(Upload)

- 1) Connect to the CPU module of the system equipped with the Ethernet module and select [Online] → [Read].

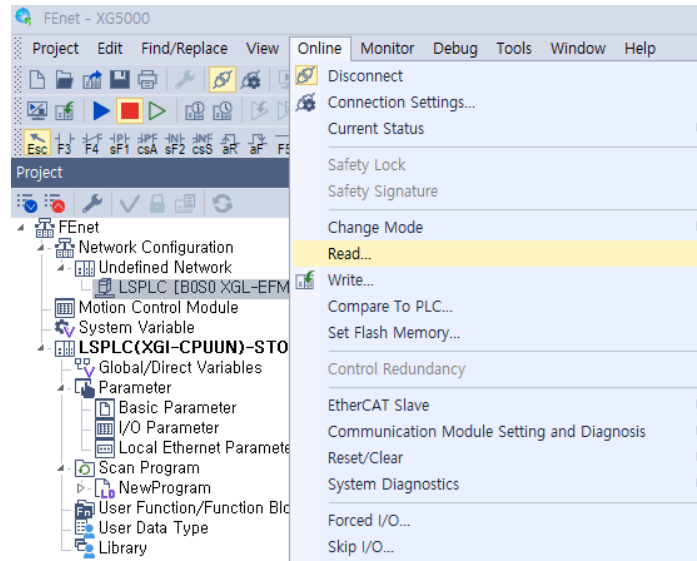

- 2) After connecting, select [Online]→ [Read] and the following screen will appear.

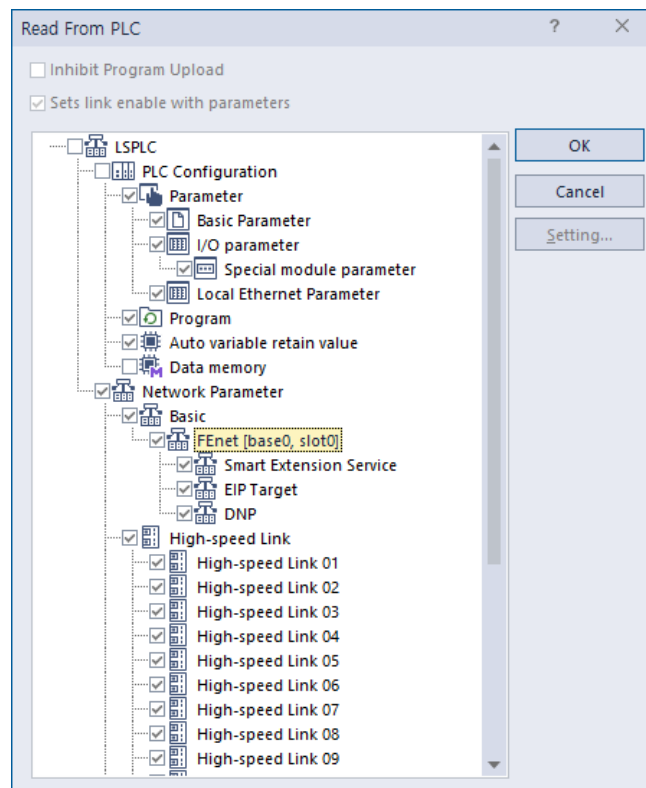

- 3) Click the "OK" button to complete reading. If reading is completed and clicks the parameter to check, the data read from CPU module can be checked on XG5000 screen.

3.5.9 Link enable

In order to send / receive high speed link and P2P data downloaded to XG5000, link permission to start communication operation is required. By allowing link enable, communication module initiates sending / receiving service. Each parameter can be individually assigned an action. If the link is enabled even when the CPU module is stopped, communication will continue.

(1) Link Enable on XG5000

1) Click [Online]→[Communication Module Setting and Diagnosis]→[Enables Services] and the following screen will appear.

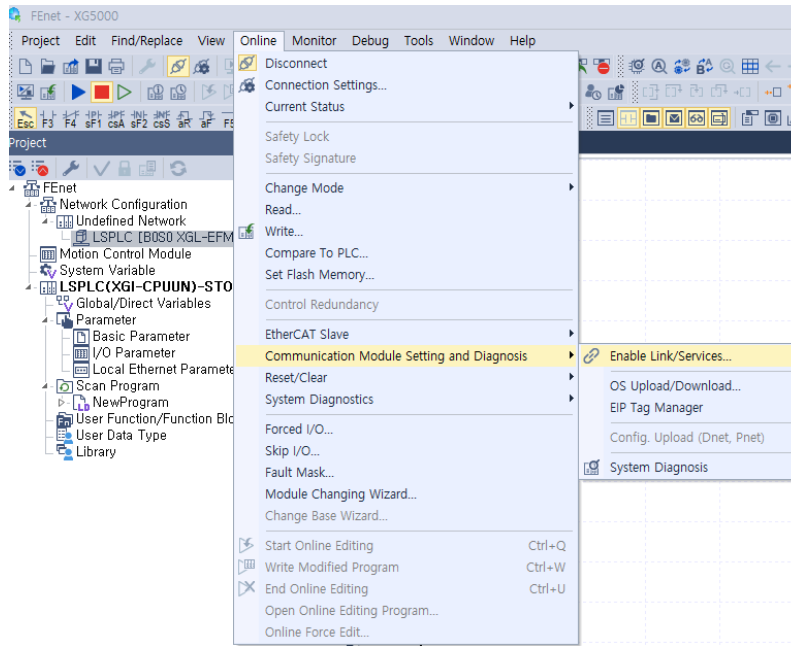

2) Set service enable for each parameter.

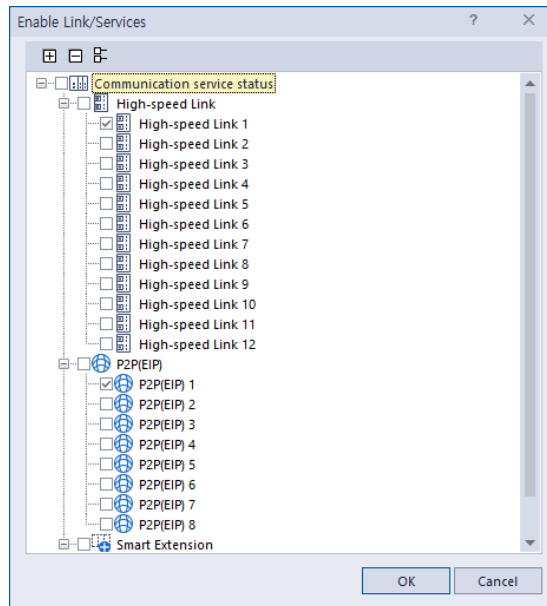

3) When the link enable write is executed, the following message appears to indicate that the link enable was successful.

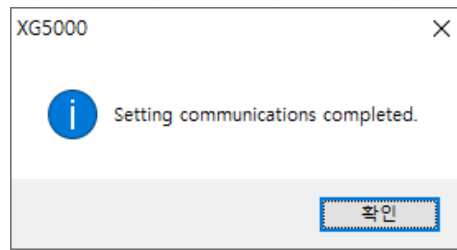

### (2) Link enable through a flag

1) Here is how to enable link via flag. The following version is required to use link enable using flag.

Item	Version
XG5000	V3.61 or higher
XGR CPU	V1.91 or higher
XGI CPU	V3.4 or higher
XGK CPU	V3.7 or higher
XGL-EFMTB	V5.0 or higher

### 2) List of flags related to link enable

-XGK CPU module

Flag	Data type	Device	Contents
_HS1_ENABLE_STATE	BIT	F09600	Current enable/disable status of high speed link NO. 1
_HS2_ENABLE_STATE	BIT	F09601	Current enable/disable status of high speed link NO. 2
_HS3_ENABLE_STATE	BIT	F09602	Current enable/disable status of high speed link NO. 3
_HS4_ENABLE_STATE	BIT	F09603	Current enable/disable status of high speed link NO. 4
_HS5_ENABLE_STATE	BIT	F09604	Current enable/disable status of high speed link NO. 5
_HS6_ENABLE_STATE	BIT	F09605	Current enable/disable status of high speed link NO. 6
_HS7_ENABLE_STATE	BIT	F09606	Current enable/disable status of high speed link NO. 7
_HS8_ENABLE_STATE	BIT	F09607	Current enable/disable status of high speed link NO. 8
_HS9_ENABLE_STATE	BIT	F09608	Current enable/disable status of high speed link NO. 9
_HS10_ENABLE_STATE	BIT	F09609	Current enable/disable status of high speed link NO. 10
_HS11_ENABLE_STATE	BIT	F0960A	Current enable/disable status of high speed link NO. 11
_HS12_ENABLE_STATE	BIT	F0960B	Current enable/disable status of high speed link NO. 12
_HS1_REQ	BIT	F10300	Request enable/disable for high speed link No. 1
_HS2_REQ	BIT	F10301	Request enable/disable for high speed link No. 2
_HS3_REQ	BIT	F10302	Request enable/disable for high speed link No. 3
_HS4_REQ	BIT	F10303	Request enable/disable for high speed link No. 4
_HS5_REQ	BIT	F10304	Request enable/disable for high speed link No. 5
_HS6_REQ	BIT	F10305	Request enable/disable for high speed link No. 6
_HS7_REQ	BIT	F10306	Request enable/disable for high speed link No. 7
_HS8_REQ	BIT	F10307	Request enable/disable for high speed link No. 8
_HS9_REQ	BIT	F10308	Request enable/disable for high speed link No. 9
_HS10_REQ	BIT	F10309	Request enable/disable for high speed link No. 10
_HS11_REQ	BIT	F1030A	Request enable/disable for high speed link No. 11
_HS12_REQ	BIT	F1030B	Request enable/disable for high speed link No. 12
_HS1_REQ_NUM	BIT	F10310	Set enable/disable for high speed link No. 1
_HS2_REQ_NUM	BIT	F10311	Set enable/disable for high speed link No. 2

Flag	Data type	Device	Contents
_HS3_REQ_NUM	BIT	F10312	Set enable/disable for high speed link No. 3
_HS4_REQ_NUM	BIT	F10313	Set enable/disable for high speed link No. 4
_HS5_REQ_NUM	BIT	F10314	Set enable/disable for high speed link No. 5
_HS6_REQ_NUM	BIT	F10315	Set enable/disable for high speed link No. 6
_HS7_REQ_NUM	BIT	F10316	Set enable/disable for high speed link No. 7
_HS8_REQ_NUM	BIT	F10317	Set enable/disable for high speed link No. 8
_HS9_REQ_NUM	BIT	F10318	Set enable/disable for high speed link No. 9
_HS10_REQ_NUM	BIT	F10319	Set enable/disable for high speed link No. 10
_HS11_REQ_NUM	BIT	F1031A	Set enable/disable for high speed link No. 11
_HS12_REQ_NUM	BIT	F1031B	Set enable/disable for high speed link No. 12
_P2P1_ENABLE_STATE	BIT	F09620	P2P1 enable/disable current status
_P2P2_ENABLE_STATE	BIT	F09621	P2P2 enable/disable current status
_P2P3_ENABLE_STATE	BIT	F09622	P2P3 enable/disable current status
_P2P4_ENABLE_STATE	BIT	F09623	P2P4 enable/disable current status
_P2P5_ENABLE_STATE	BIT	F09624	P2P5 enable/disable current status
_P2P6_ENABLE_STATE	BIT	F09625	P2P6 enable/disable current status
_P2P7_ENABLE_STATE	BIT	F09626	P2P7 enable/disable current status
_P2P8_ENABLE_STATE	BIT	F09627	P2P8 enable/disable current status
_P2P1_REQ	BIT	F10320	Request enable/disable for P2P No. 1
_P2P2_REQ	BIT	F10321	Request enable/disable for P2P No. 2
_P2P3_REQ	BIT	F10322	Request enable/disable for P2P No. 3
_P2P4_REQ	BIT	F10323	Request enable/disable for P2P No. 4
_P2P5_REQ	BIT	F10324	Request enable/disable for P2P No. 5
_P2P6_REQ	BIT	F10325	Request enable/disable for P2P No. 6
_P2P7_REQ	BIT	F10326	Request enable/disable for P2P No. 7
_P2P8_REQ	BIT	F10327	Request enable/disable for P2P No. 8
_P2P1_REQ_NUM	BIT	F10330	Set enable/disable for P2P No. 1
_P2P2_REQ_NUM	BIT	F10331	Set enable/disable for P2P No. 2
_P2P3_REQ_NUM	BIT	F10332	Set enable/disable for P2P No. 3
_P2P4_REQ_NUM	BIT	F10333	Set enable/disable for P2P No. 4
_P2P5_REQ_NUM	BIT	F10334	Set enable/disable for P2P No. 5
_P2P6_REQ_NUM	BIT	F10335	Set enable/disable for P2P No. 6
_P2P7_REQ_NUM	BIT	F10336	Set enable/disable for P2P No. 7
_P2P8_REQ_NUM	BIT	F10337	Set enable/disable for P2P No. 8

-XGI CPU module

Flag	Data type	Device	Contents
_HS_ENABLE_STATE	ARRAY[0..11] OF BOOL	%FX15840	HS enable/disable current status
_HS_REQ	ARRAY[0..11] OF BOOL	%FX16480	HS enable/disable request
_HS_REQ_NUM	ARRAY[0..11] OF BOOL	%FX16496	Setting enable/disable for high speed link
_P2P_ENABLE_STATE	ARRAY[0..7] OF BOOL	%FX15872	P2P enable/disable current status
_P2P_REQ	ARRAY[0..7] OF BOOL	%FX16512	P2P enable/disable request
_P2P_REQ_NUM	ARRAY[0..7] OF BOOL	%FX16528	Setting P2P enable/disable

-XGR CPU module

Flag	Data type	Device	Contents
_HS_ENABLE_STATE	ARRAY[0..11] OF BOOL	%FX19040	HS enable/disable current status
_HS_REQ	ARRAY[0..11] OF BOOL	%FX31520	HS enable/disable request

_HS_REQ_NUM	ARRAY[0..11] OF BOOL	%FX31536	Setting enable/disable for high speed link
_P2P_ENABLE_STATE	ARRAY[0..7] OF BOOL	%FX19072	P2P enable/disable current status
_P2P_REQ	ARRAY[0..7] OF BOOL	%FX31552	P2P enable/disable request
_P2P_REQ_NUM	ARRAY[0..7] OF BOOL	%FX31568	Setting P2P enable/disable

- ▶ Link enable method
  - Set flag on in set enable/disable for high speed link/P2P → Set flag on in request enable/disable for high speed link/P2P
- ▶ Disable enable method
  - Set flag off in set enable/disable for high speed link/P2P → Set flag on in request enable/disable for high speed link/P2P
- ▶ The enable / disable status flag of HS link / P2P can be used to monitor the enable / disable status of the HS link.

### 3.6 System diagnosis

The system diagnosis function indicates the overall service status and information communication module. It shows detailed online status such as link type, link information and O/S information so that users can diagnose and debug data send/ receive relationship of current communication module.

#### 3.6.1 Diagnostics

When select [Online]->[Communication Module Setting and Diagnosis]->[System Diagnosis],the following screen will be displayed.

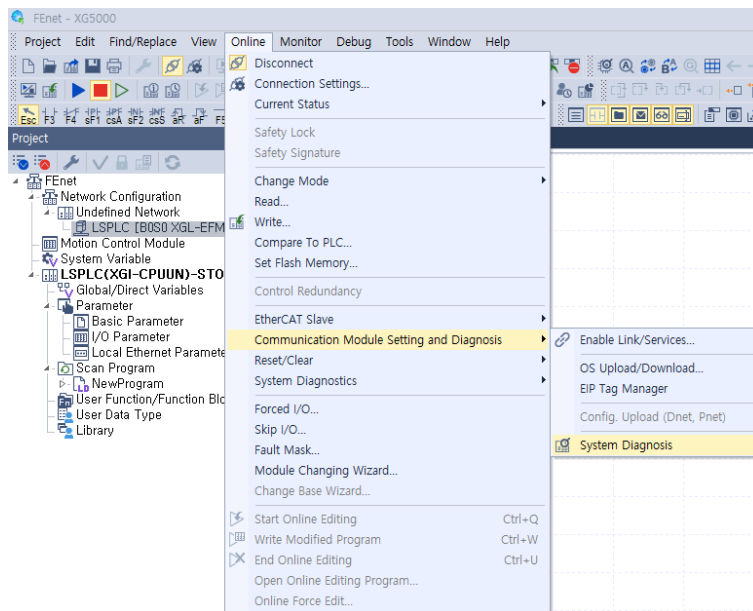

It displays the base information, slot information and CPU operation status of the installed module.

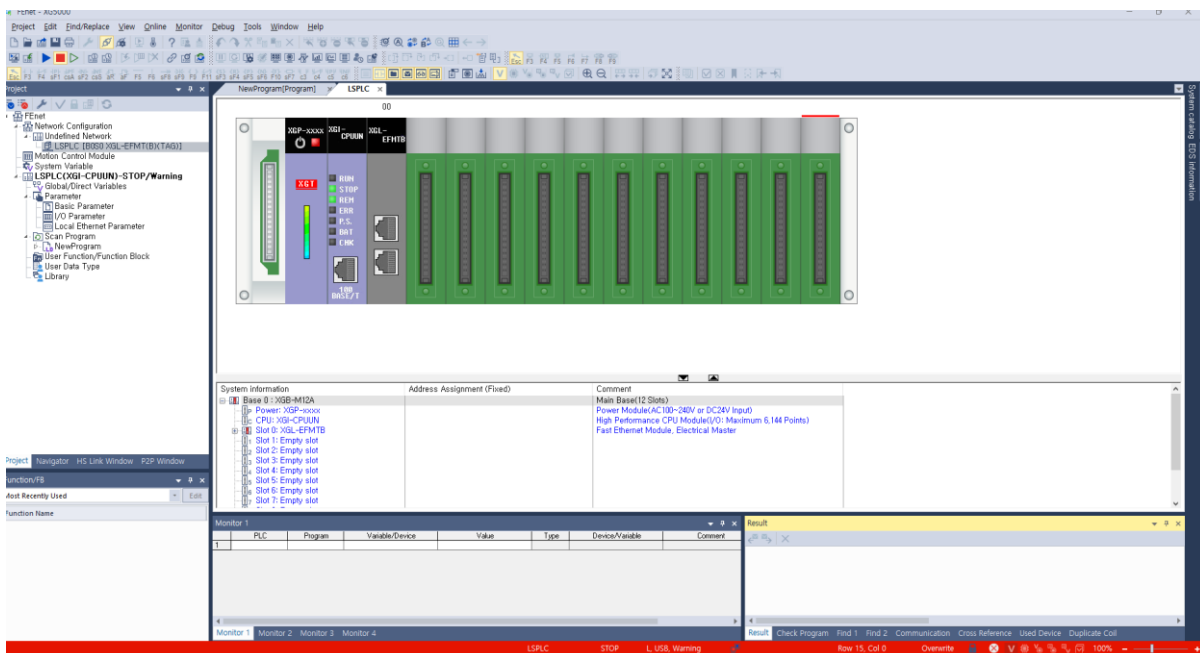

### 3.6.2 Types of diagnostic functions

On the diagnosis screen, diagnose the status of each module with the pop-up menu. The main functions of each item are as follows.

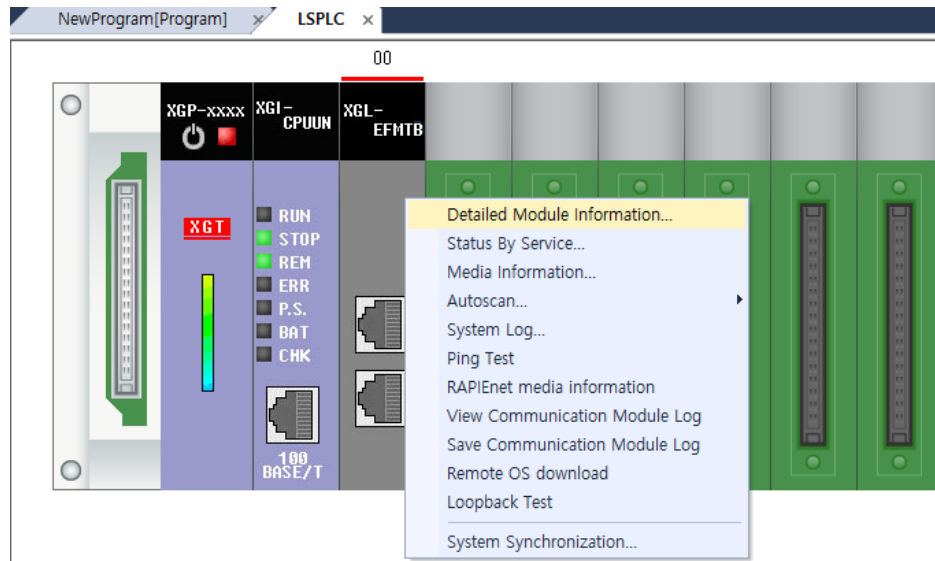

Classification		Content
Detailed Module Information		It shows basic information, hardware and communication status of communication module.
Status By Service		Dedicated service, P2P service, High Speed Link service, Smart extension status are displayed.
Media information		Provides packet information of data sent and received through the media.
Auto scan	Ethernet Autoscan	It provides IP information of our module connected to the Ethernet network and activated.
	RAPIEnet Autoscan (V6.0 or higher)	Provides RAPIEnet module and configuration information connected RAPIEnet network.
	EtherNet/IP Autoscan (V8.0 or higher)	Provides module and configuration information connected to EtherNet / IP network.
	RAPIEnet + Autoscan (V8.10 or higher)	Provides information on networks composed of RAPIEnet and EtherNet / IP modules.
System Log		It is a function to check the system operation, Modbus Service, P2P Service log. Provides brief log information of communication module.
Ping Test		This shows the port connection status of other station connected to the network.
RAPIEnet media information (V6.0 or higher)		Provide packet information for RAPIEnet.
View Communication Module Log (V6.0 or higher)		Provides event / communication history information of the communication module.
Save Communication Module Log (V6.0 or higher)		Compress and saves event / communication history information of the communication module.
Remote OS download (V6.0 or higher)		With RAPIEnet enable, the OS of the remote module connected to the network is updated using the RAPIEnet protocol.
Loop-back test (V6.0 or higher)		It is a function to check whether there is an abnormality in the port of the local module, and performs loopback test for each port.
System synchronization		Synchronizes the current PLC status to system diagnostics.

(1) Communication Module Information

Communication module information shows Standard information such as base information, HS link station no., IP information and start status of media and communication service. This allows the user to check whether the communication module is in normal state.

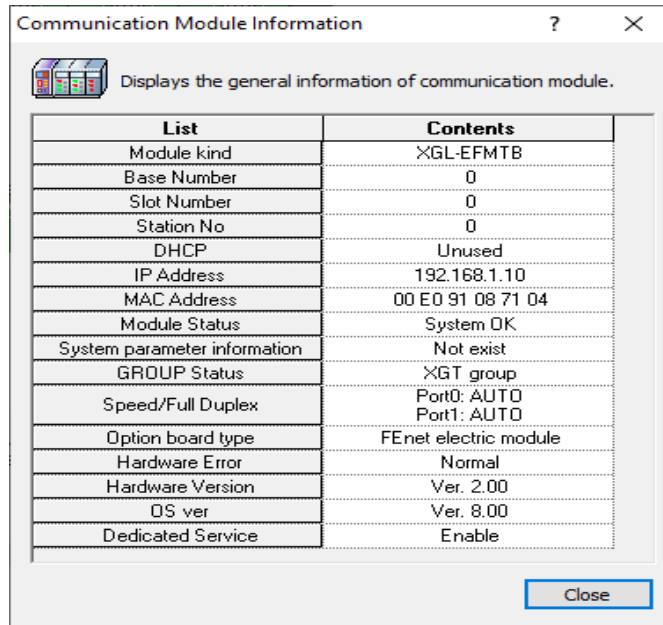

(2) Status By Service

The service status of communication module is divided into Dedicated Service, P2P Service, High Speed Link Service and Smart Extension and shows the detailed information of each communication service.

1) Dedicated service

Dedicated service shows communication status with MMI / HMI, the parent client. Displays the send/ receive data and error with the client of the set IP address.

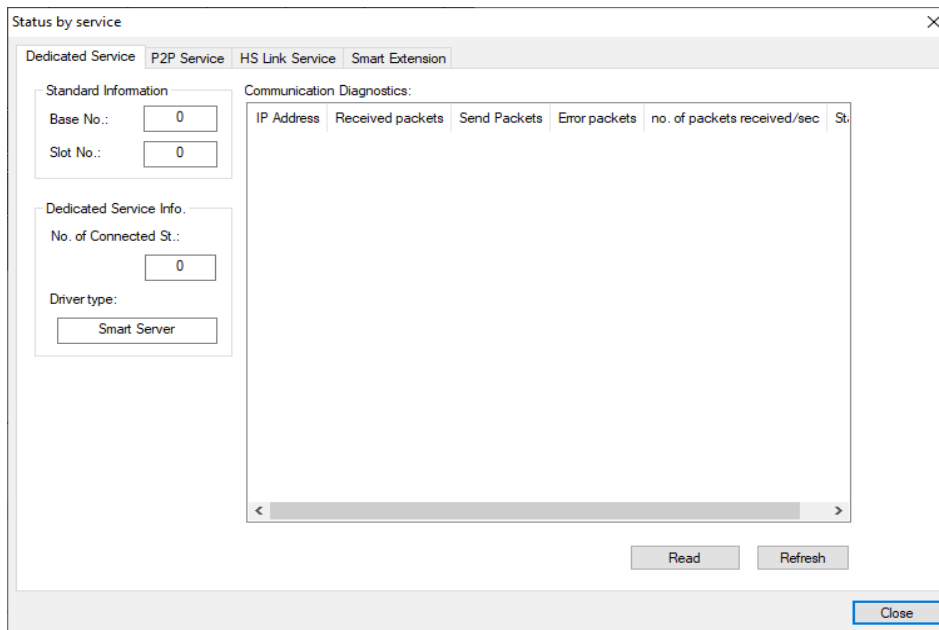

2) P2P service

When P2P parameter is set and enabled, it indicates whether the service is normal or not. Real-time monitoring is possible by specifying redo and continuous read through menu.

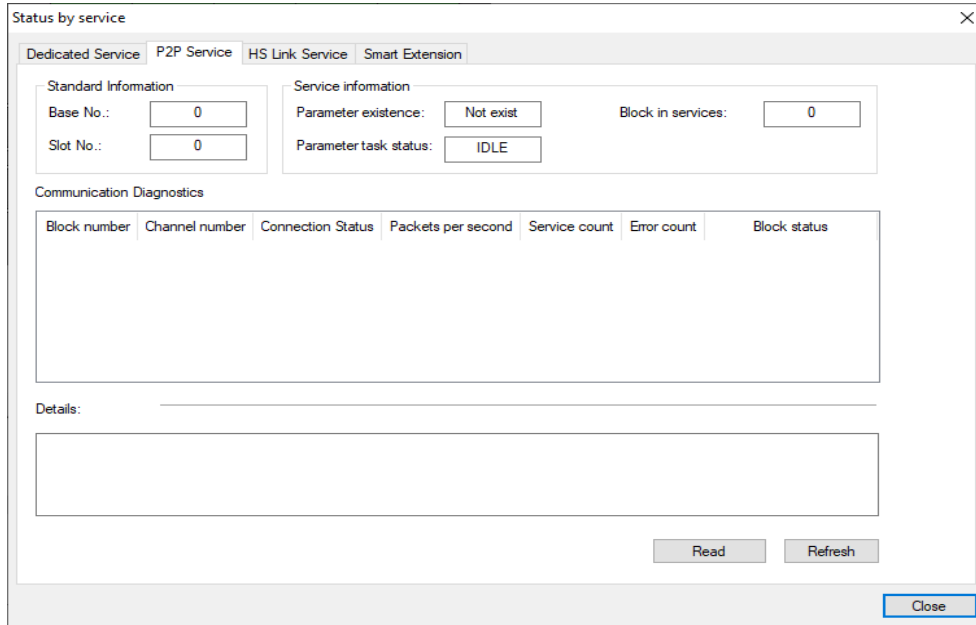

3) HS Link Service

Monitoring by flag is performed for individual parameters of HS link parameter. HS link service information displays individual information such as run link and link trouble.

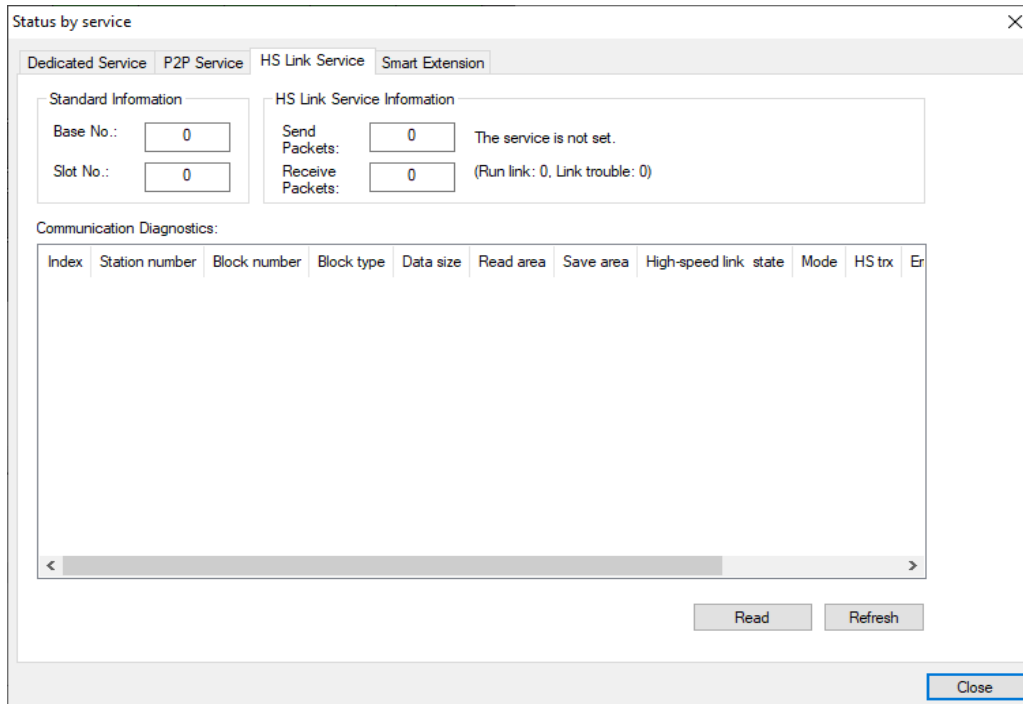

4) Smart Extension

Monitoring by flag is performed for individual parameters of Smart Extension HS link parameter. HS link service information displays individual information such as run link and link trouble.

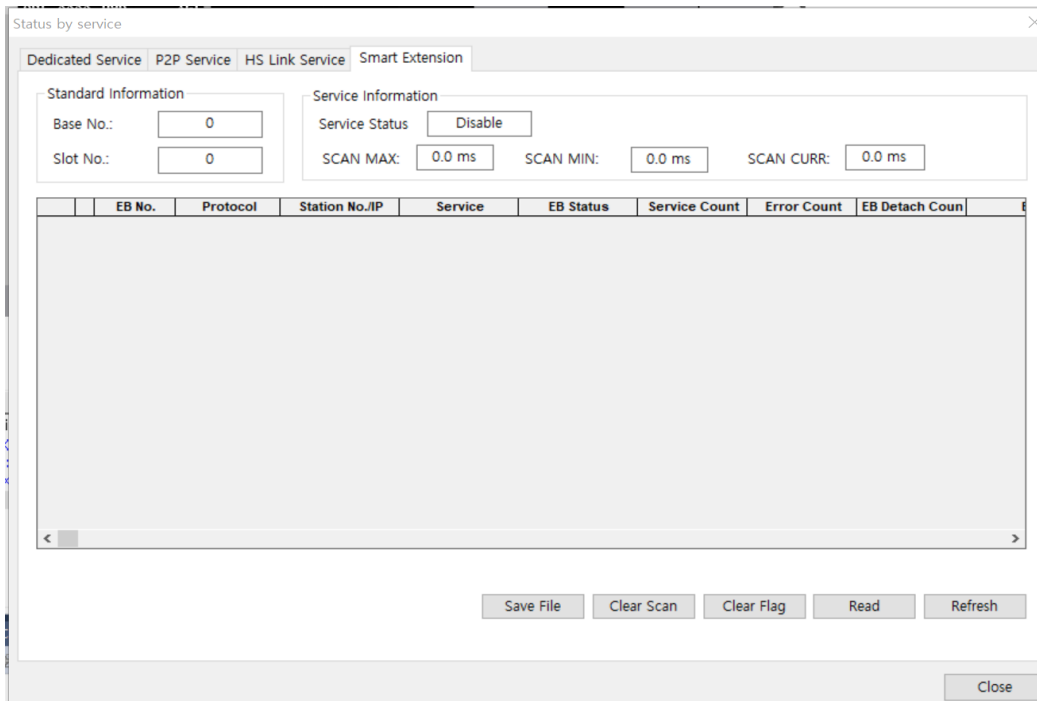

(3) Media information

Indicates packet information input to the media.

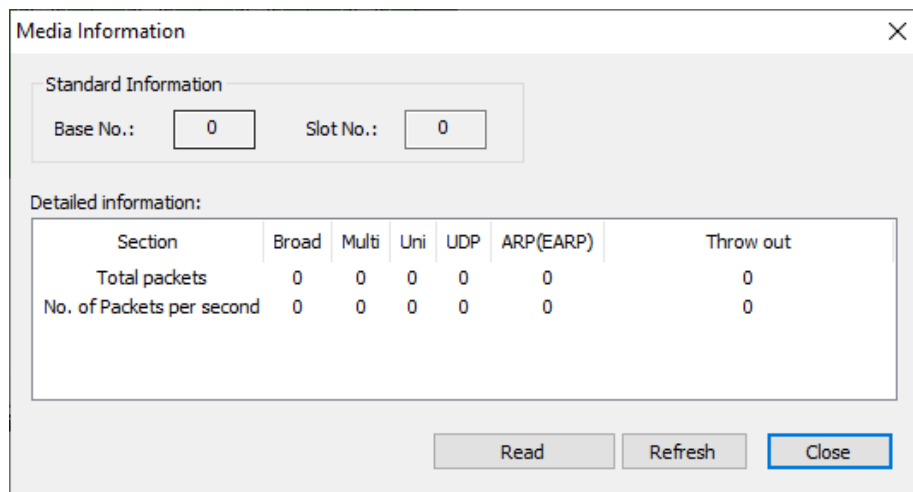

(4) Ping Test

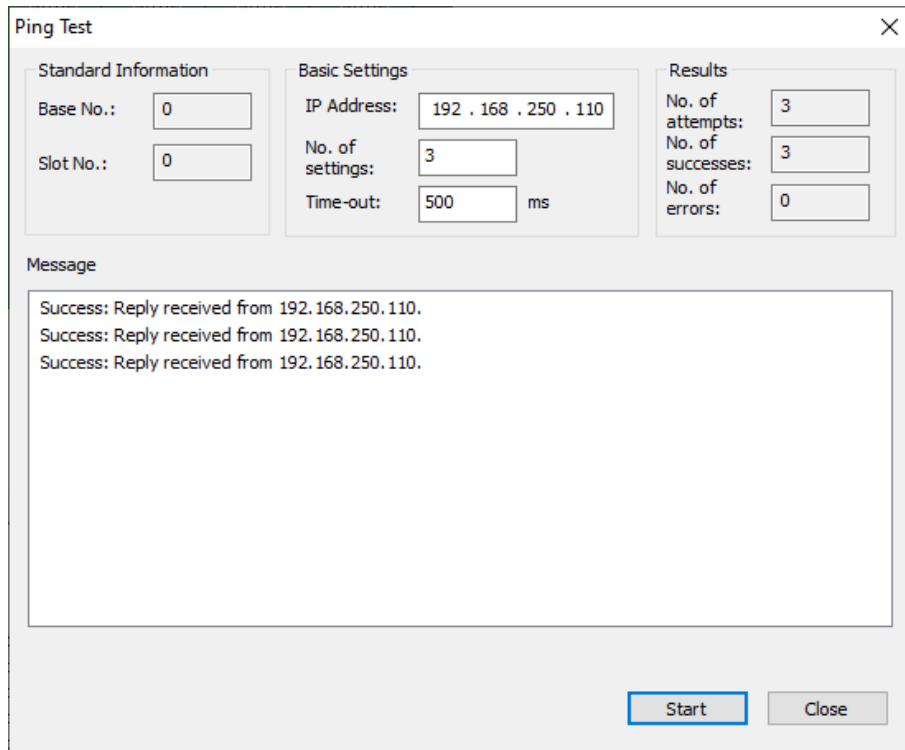

(5) Auto scan

Indicates the link interface status of the network.

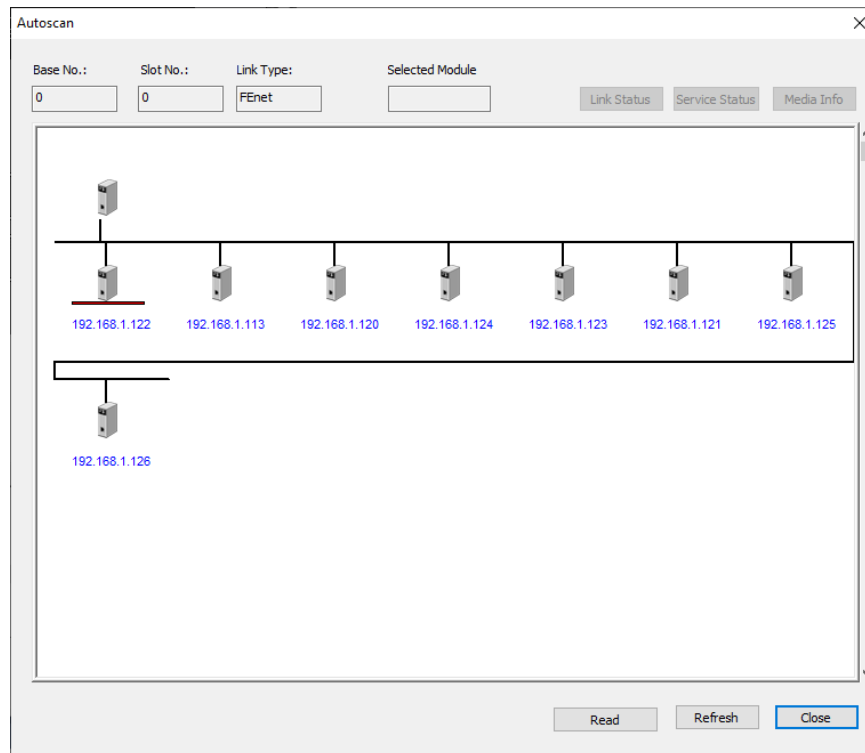

(6) RAPIEnet media information(Module version V6.0 or higher)

Indicates the link interface status of the network.

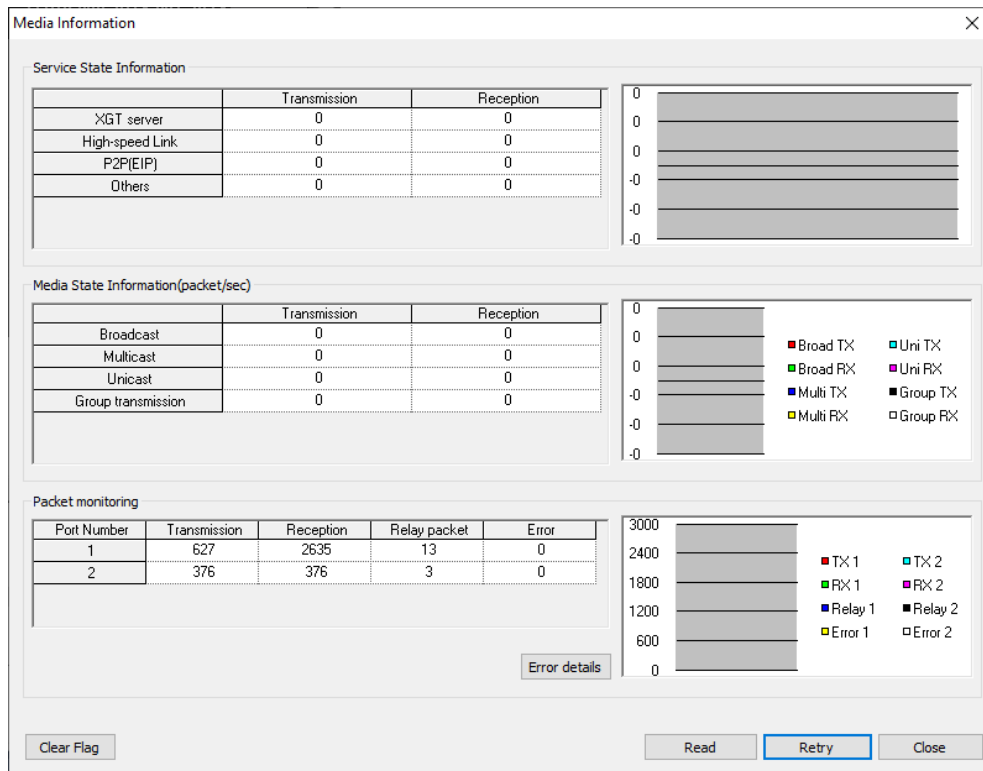

(7) RAPIEnet autoscan(Module version V6.0 or higher:)

Indicates the link interface status of the network.

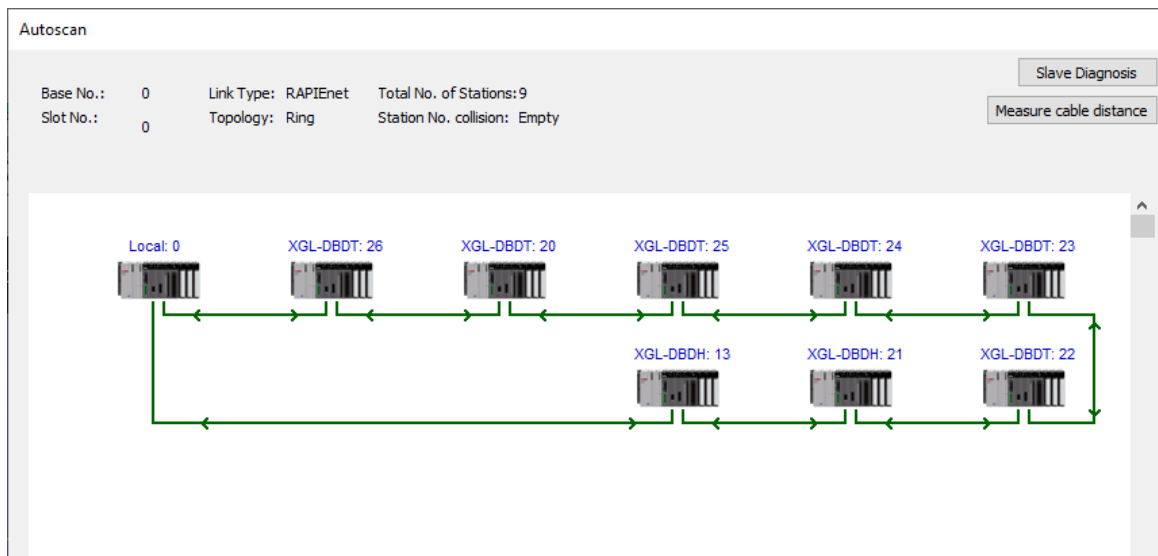

(8) Saving and comparing RAPIenet autoscans (V8.1 or higher)

This function compares the results of the previous RAPIenet autoscan with the results of the current RAPIenet autoscan in RAPIenet autoscan. Executing RAPIenet autoscan in [Online] → [communication Module Setting and Diagnosis] → [System diagnosis].

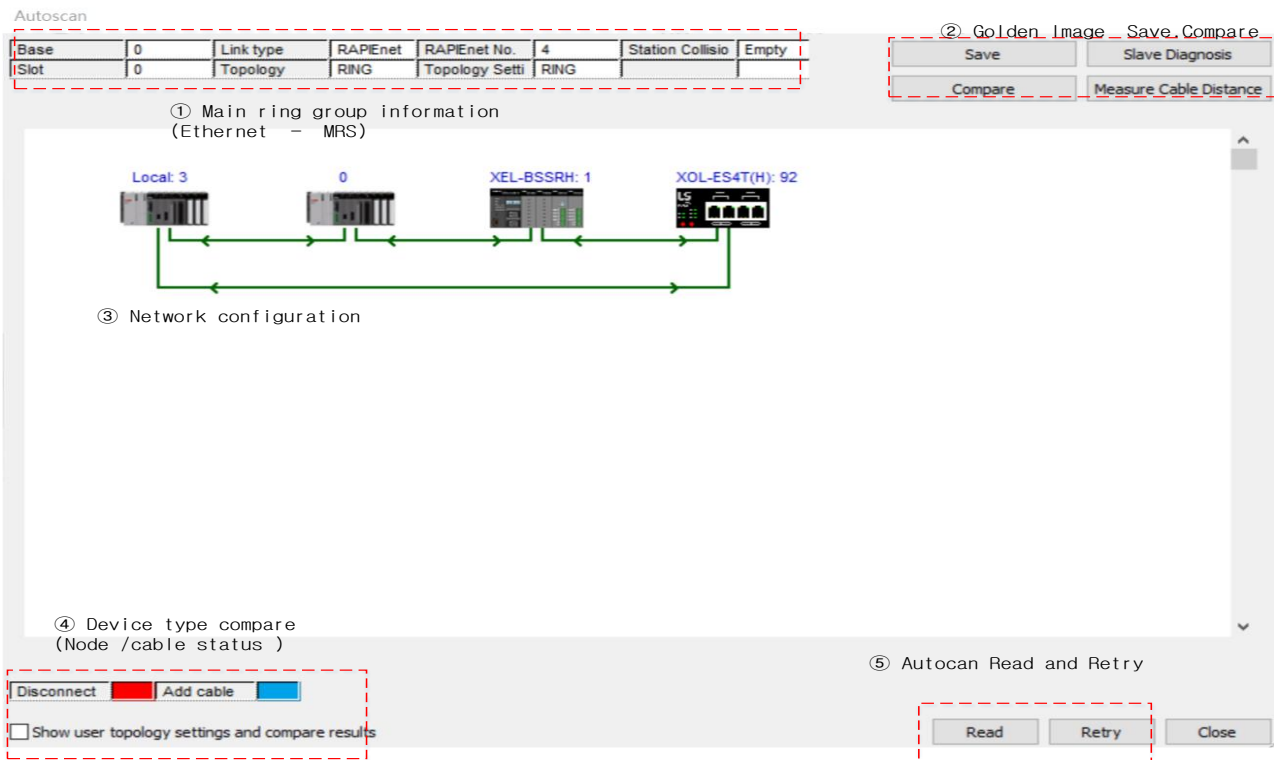

1) Main ring group information

Monitors network information connected to the master module configured for smart expansion.

2) Golden image Save, Compare

Measure the cable distance of the auto-scanned network and compare the network configuration information.

- Save: Saves the connected network configuration information. Check the network change information by running Compare using Save.
- Slave Diagnosis: Monitor the cable connection status and connection location of Smart I/ for.
- Compare: If you execute Compare, the difference between the network configuration saved with the Save menu and the current network configuration information is compared and displayed in the network configuration.
- Cable distance measurement: Measures the cable distance between networks in M.

Module	Electric transceiver	Optic transceiver	Note
Ethernet Expansion driver Smart I/O block	Distance: Display m Date :Display 2021-01-11	Distance(Not display): Fiber Optic Date :Display 2021-01-11	
MRS Smart expansion I/O	Distance: Display - m Date : Display 2021-01-11 or N/A	Distance(Not display): Fiber Optic Date : Display 2021-01-11 or N/A	Not supported

3) Network configuration

Displays the network information executed by Auto Scan and the result of executing Golden image.

4) Device type compare

If you select Compare from the Save and Compare menu in Golden image, the saved information and network change information are visually displayed. In addition, if you select to “display the user topology setting and comparison result”, the difference between the topology set in the smart expansion and the current topology is displayed.

5) Auto scan redo and continuous read

If continuous reading is selected from the menu to perform auto scan, auto scan is executed continuously. And when you select Redo, the autoscan information that was re-run is displayed.

If you execute Save from the Golden image Save and Compare menu, the following screen is display.

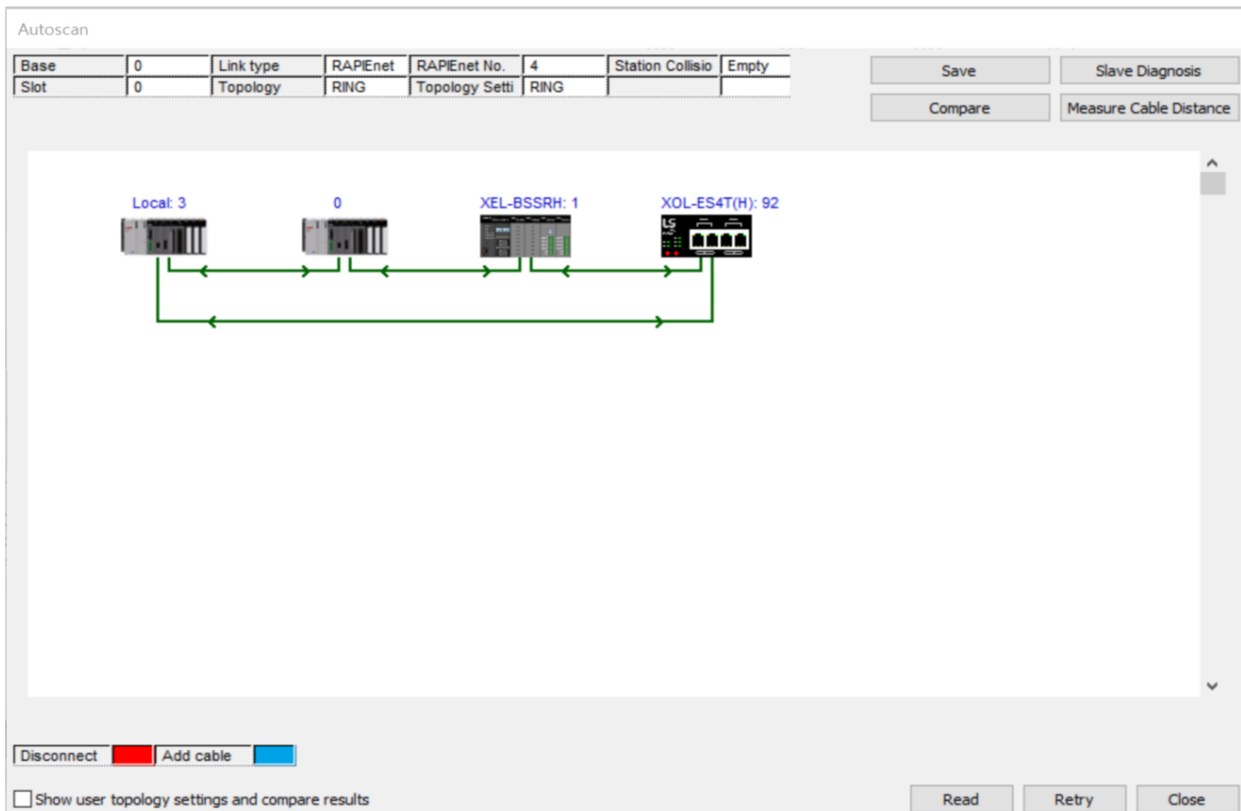

If you execute Compare from the Golden image Save and Compare menu, the following screen is display. In other words, it indicates the cable disconnection between station 0 and XEL-BSSRH (station No.1)

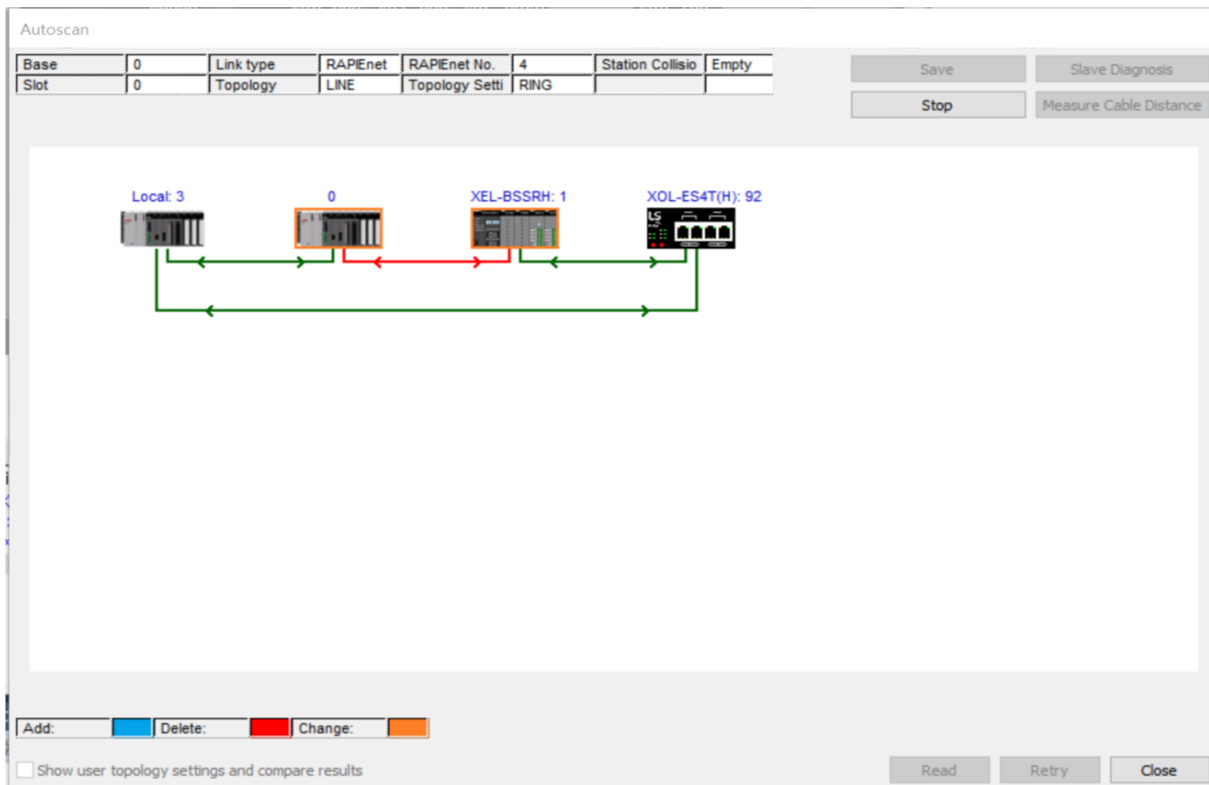

If you execute Compare from the Golden image Save and Compare menu, the following screen is display. In other words, it indicates that GEL-DT4C (station No. 4) has been added between local station No.3 and station No.0.

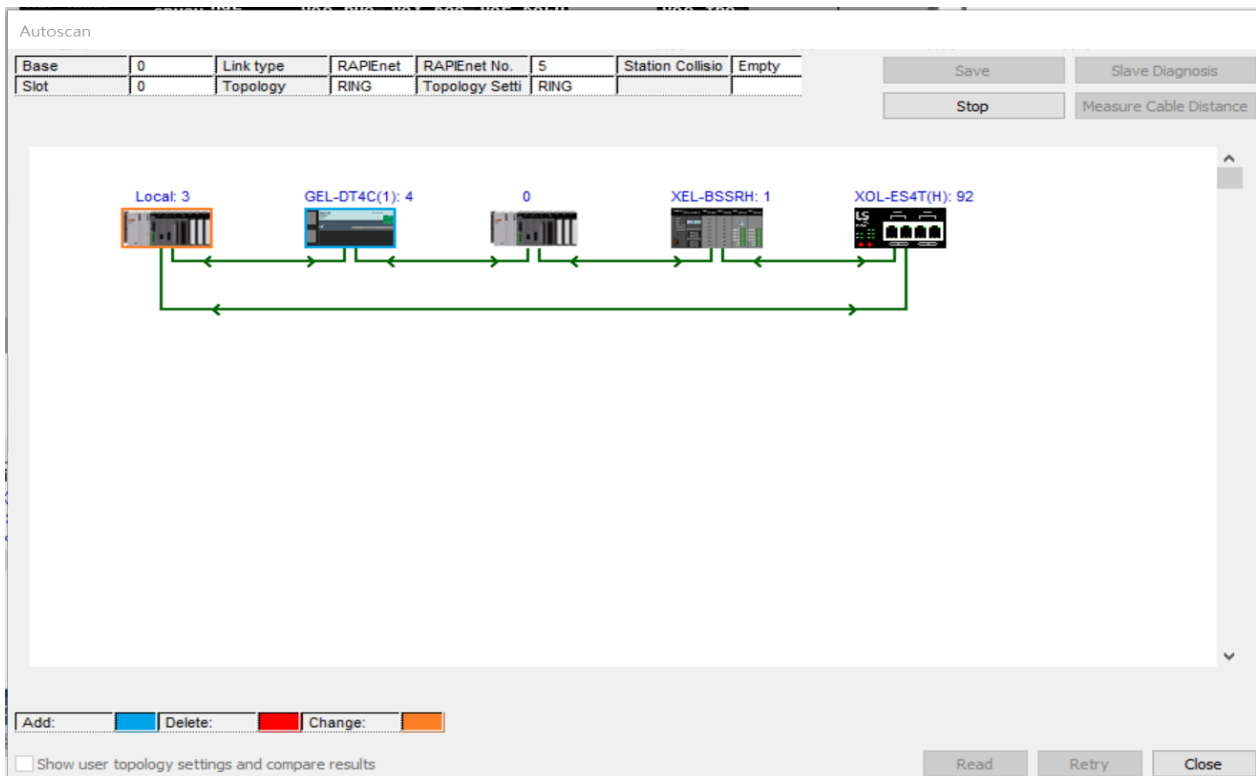

“If you select to “display the user topology setting and comparison result”, the difference between the topology set in the smart expansion and the current topology is displayed. In other words, it is set as a ring in the smart expansion, but the current topology is connected by lines.

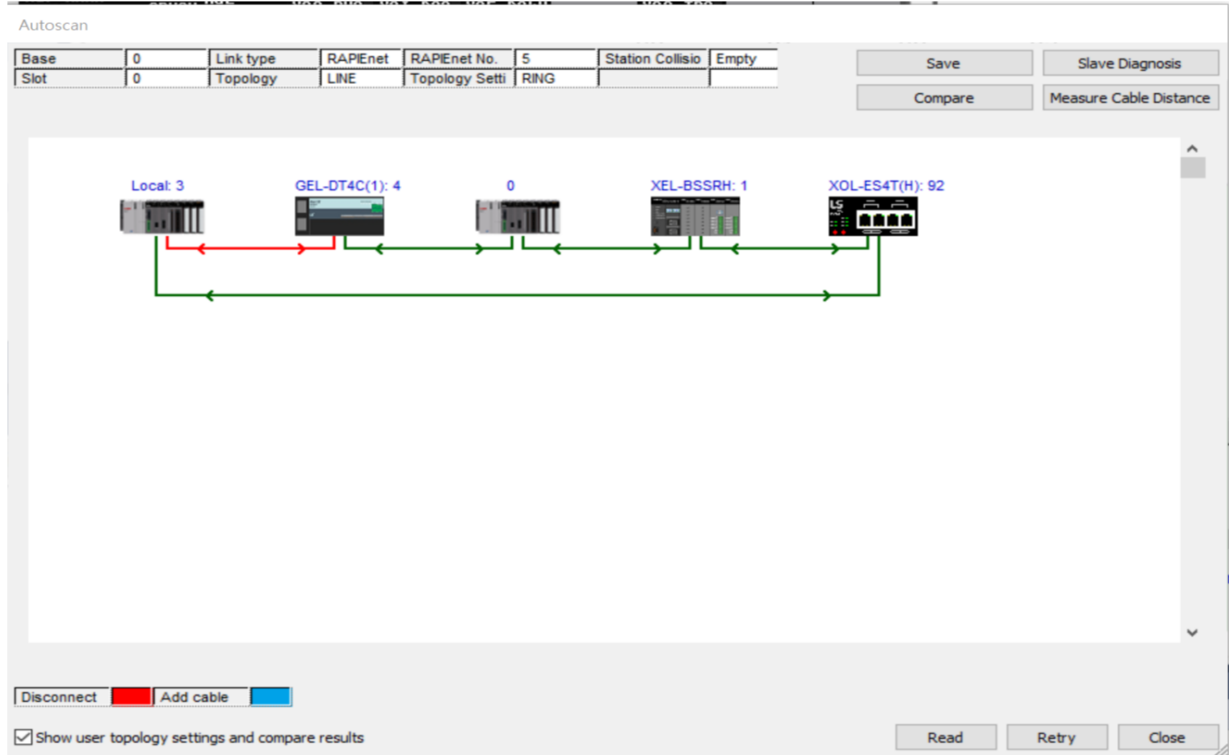

Auto scan and the currently connected cable distance are schematically expressed in the network configuration.

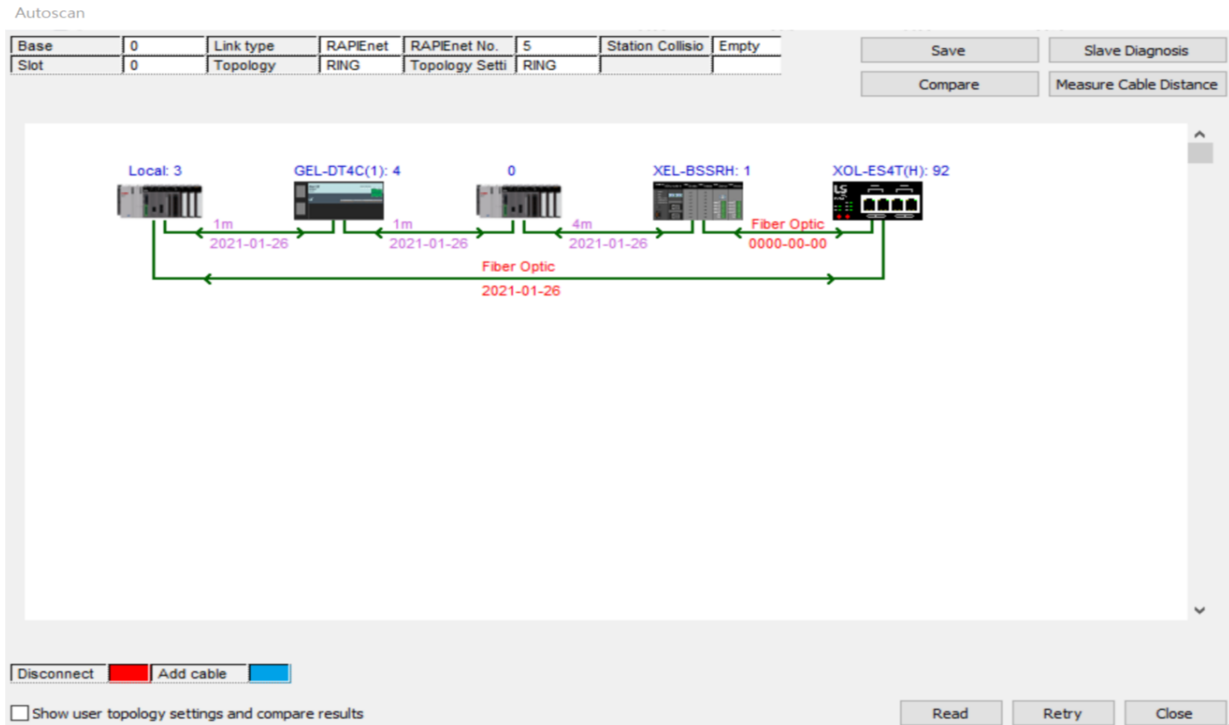

### (9) RAPIenet+ Auto Scan function (V8.10 or higher)

Auto Scan function of RAPIenet + is provided for link disconnect section detection of EtherNet / IP devices connected to XOL-ES4x (MRS). The disconnect section detection is performed by comparing the current system configuration (hereafter Live Image) based on the system configuration (hereinafter Golden Image) set by the user. Therefore, in order to use this function, after configuring the system, click the “Save” button to save the Golden Image first.

When autoscan of RAPIenet + is executed in [Online] → [Communication module setting and diagnosis] → [System Diagnosis], information about the IP device connected to the first MRS is displayed.

The figure below shows the UI of the RAPIenet + autoscan function.

Base	0	Link type	RAPIenet	RAPIenet No.	5	Station Collisio	Empty
Slot	0	Topology	RING	Topology Setti	RING		

① Main Ring group information

③ Network configuration

② Golden Image  
Save/Compare

④ Device type compare  
(Node /cable status )

Disconnect ■ Add cable ■

Show user topology settings and compare results

⑤ Autoscan Retry

Read    Retry    Close

If the system configuration is complete, click the “Save” button to save Golden Image. Golden Image is saved in the communication master module and will be used in the future comparison function. Click the “Retry” button to check the current system configuration. If you click the “Compare” button, you will see the changes compared to Golden Image. There are two changes: a) adding / removing node, b) cable connection / remove.

If node No.0 is added between station No.3 and station No.1, the node added in green is displayed as shown below.

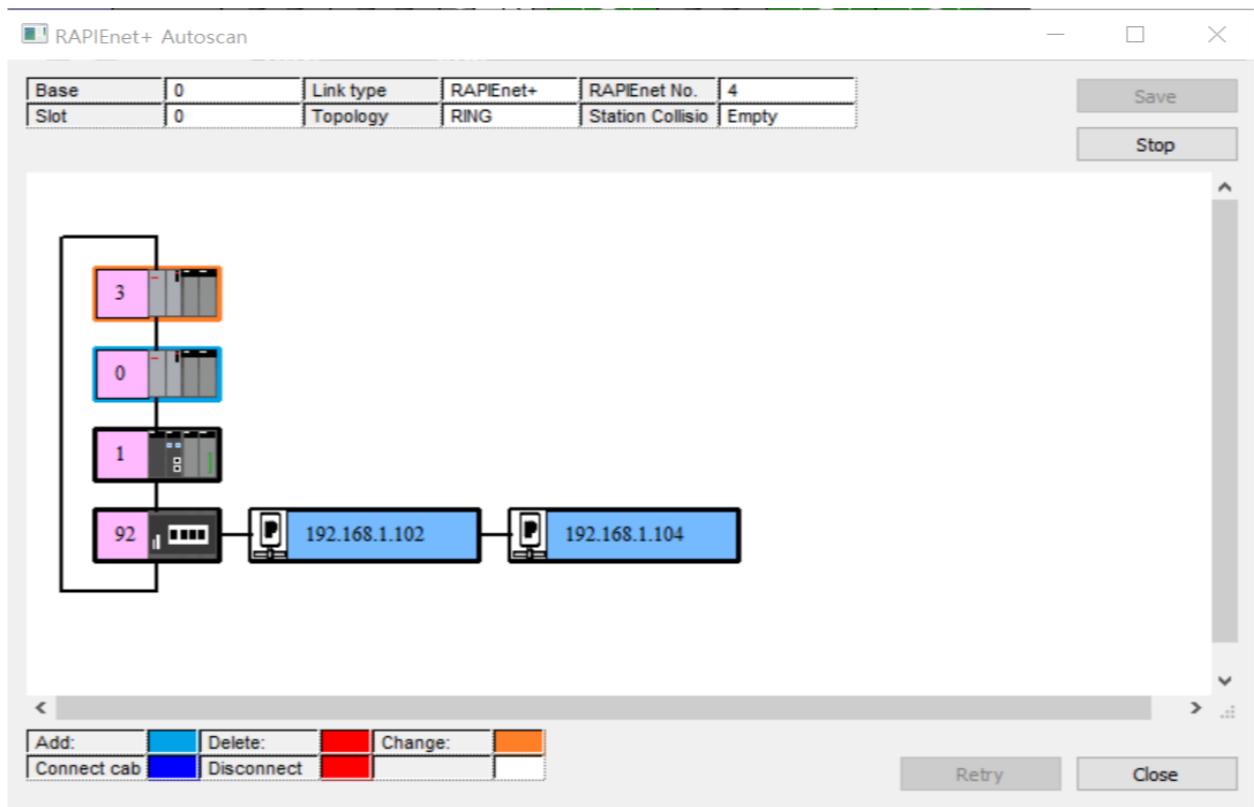

In the above state, if the cable between the node no.0 and station No.1 is removed, the disconnection section is displayed in red as shown below.

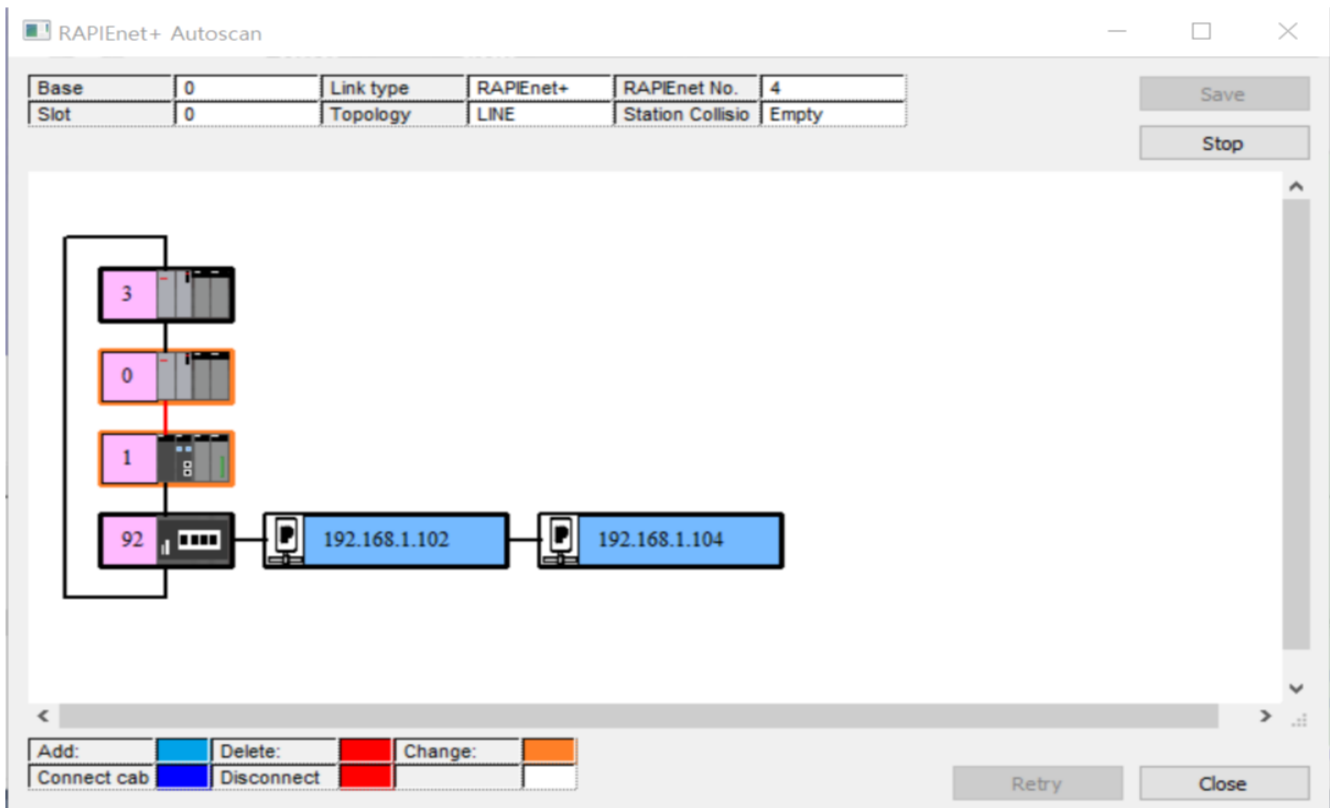

## Chapter 3 Product Installation and Test Operation

If the node cable of station No.0 and station No.1 is connected again, the connected section is indicated by a blue line as follows.

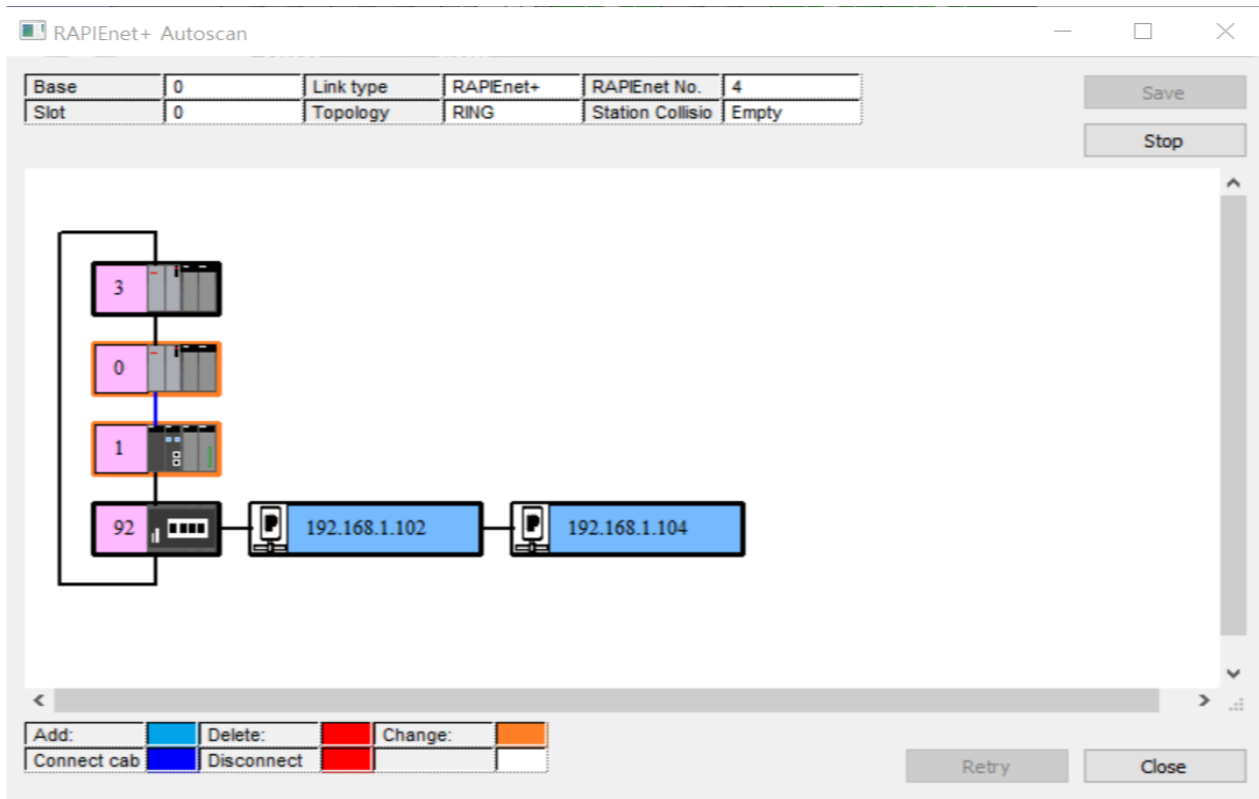

In the above state, if the node No. 0 is removed (module detachment etc.), the removed module is displayed in red, and the cable disconnection section due to the module is displayed in red.

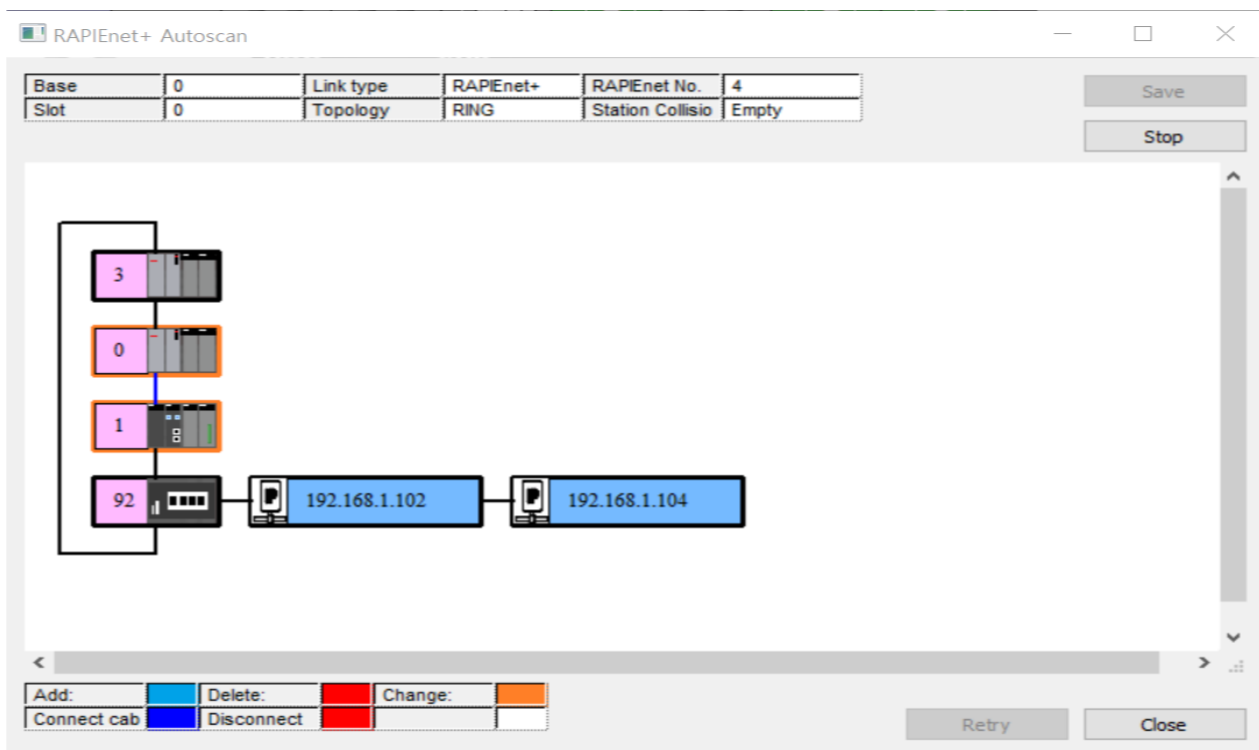

(10)View Communication Module Log(Module version V6.0 or higher)

It indicates the event and communication history of communication module.

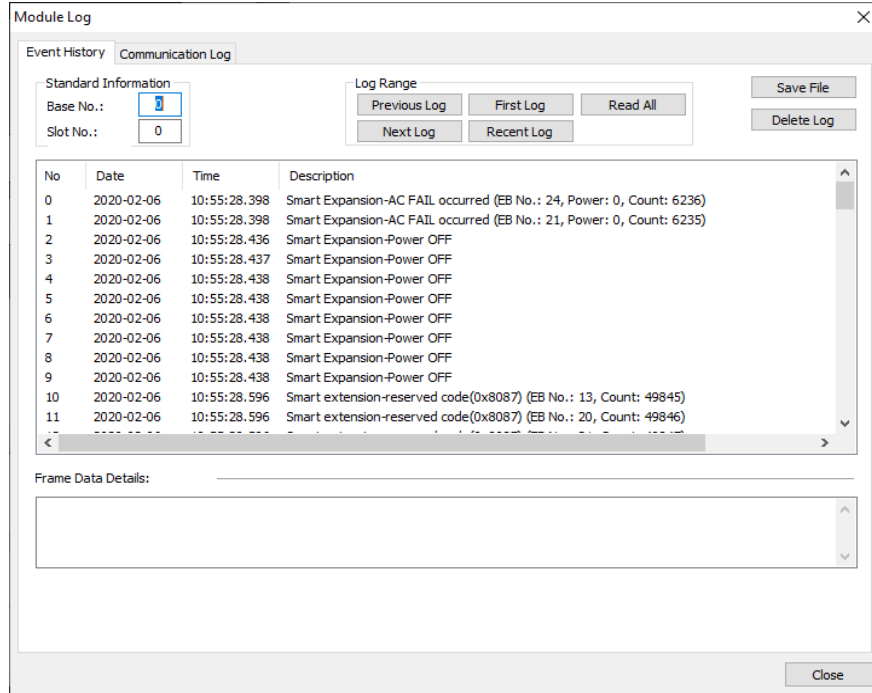

(11) Remote OS download(Module version V6.0 or higher)

Update OS of remote communication module.

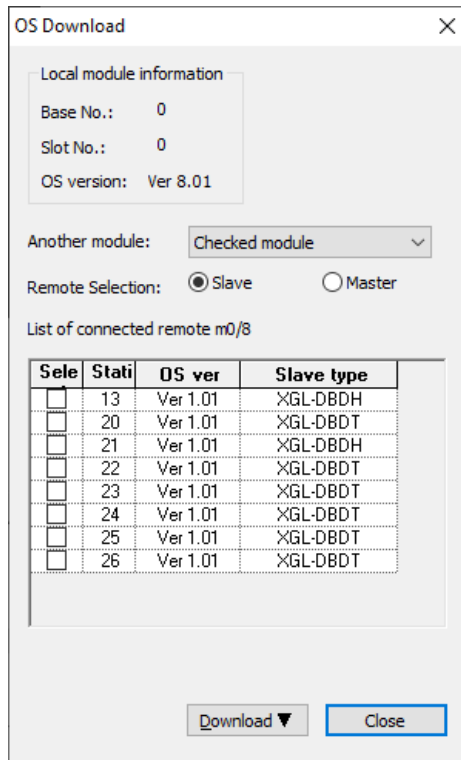

### (12) Loopback test(Module version V6.0 or higher)

The loopback test of the local Ethernet module is used to test the hardware for abnormalities.

Loopback Test

Standard Information

Base No.: 0

Slot No.: 0

Basic Settings

Select port: Port1

Loopback Test: INTERNAL MAC

No. of settings: 3 (1 - 10)

Results

# of attempts:

# of successes:

# of errors:

Message

Start Cancel

#### Notes

- 1) Reset communication module after remote OS download. If you do not reset, the communication module will not operate normally.



## Chapter 4 Smart Extension service

### 4.1 Overview

Smart extension service is a service between Ethernet (FEnet) module V8.0 or higher and Communication device, that is, Expansion driver, Smart I/O expansion (XEL-BSSRT / BSSRF / BSSRH), Smart I / O block. It is a service that can be used like one system by adding several PLCs with simple setting.

In the case of XGL-EFMx (B) V8.0, EtherNet / IP function is newly added, and client function of EtherNet / IP function is integrated in Smart expansion service.

The function of the Smart Extension Service is as follows.

(1) Communication Device control function

1) Communication devices that support Smart extension Service are as follows.

- Extension driver: XGL-DBDT / DBDF / DBDH
- Smart I/O expansion: XEL-BSSRT / BSSRF / BSSRH
- Smart I/O block: GEL-TR4C1 / DT4C1 / D24C / RY2C / AV8C / AC8C / DV4C / DC4C / TR4C / DT4C
- Inverter Option B/D: CE-S7M1

2) Protocols for communication between Ethernet modules and Communication devices are RAPIEnet v2 and EtherNet / IP.

Smart extension service using RAPIEnet protocol is not supported when RAPIEnet setting of Ethernet (FEnet) module is set to RAPIEnet v1.

3) Functions such as setting and controlling a PLC equipped with a communication device.

- Station number setting of Communication device is available to set remotely from Ethernet module (client) only if station number switch of communication device is '00'.

For details on setting station No. of communication device, refer to the communication device manual.

## 4.2 Smart extension service setting

Smart Extension service can be easily set by selecting parameters for each item in XG5000. The setting procedure and the function of each item are as follows.

### 4.2.1 Standard settings

Smart Extension service operates according to the Standard Settings of Ethernet (FEnet). The following describes the Ethernet standard settings parameter for Smart Expansion service.

#### (1) Station No

In the Smart extension service, the station number is used as the station number of Ethernet (master) when using RAPIEnet protocol communication with the Communication device.

#### (2) RAPIEnet setting

The operation varies depending on the RAPIEnet setting in the driver setting item of the Standard Settings. EtherNet / IP protocol can be used regardless of RAPIEnet setting.

RAPIEnet setting	Smart extension service operation
Disable	RAPIEnet protocol is not used. - If set to Disable, RAPIEnet protocol cannot be used to connect communication devices in Smart extension service, and only Ethernet / IP protocol can be used.
RAPIEnet v1	RAPIEnet v1 is used. (Same as the existing LSIS RAPIEnet.) - If set to RAPIEnet v1, RAPIEnet protocol cannot be used to connect communication devices in Smart extension service, and only Ethernet / IP protocol can be used.
RAPIEnet v2	RAPIEnet v2 (IEC Standard) is used. - When set to RAPIEnet v2, RAPIEnet and Ethernet / IP protocols can be used for

connection of Communication devices in Smart extension service.  
 - If RAPIenet protocol is used in Smart Extension service, ring configuration and High Speed communication between own networks are possible.

### 4.2.2 Smart extension service

- (1) Click the [Project] tab on the left project window and select by right clicking on the communication module item on the tree.

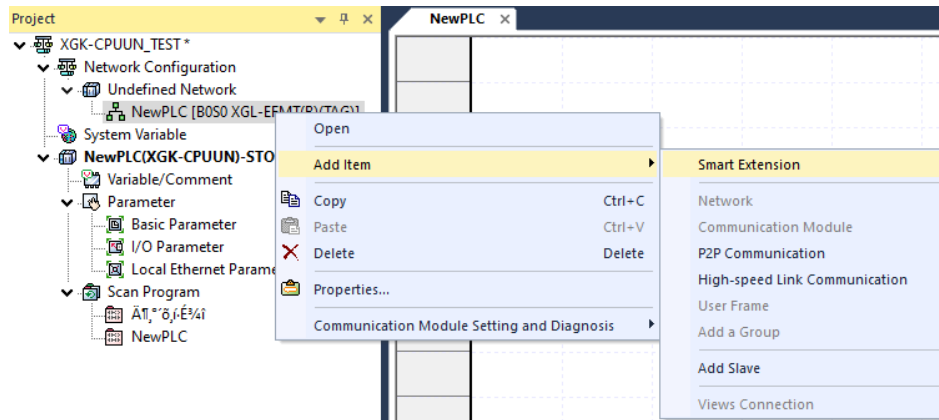

- (2) If you want to use the Smart Extension Wizard to set up the Smart extension service, select "Next" in the [Overview] window of the Smart extension Wizard.

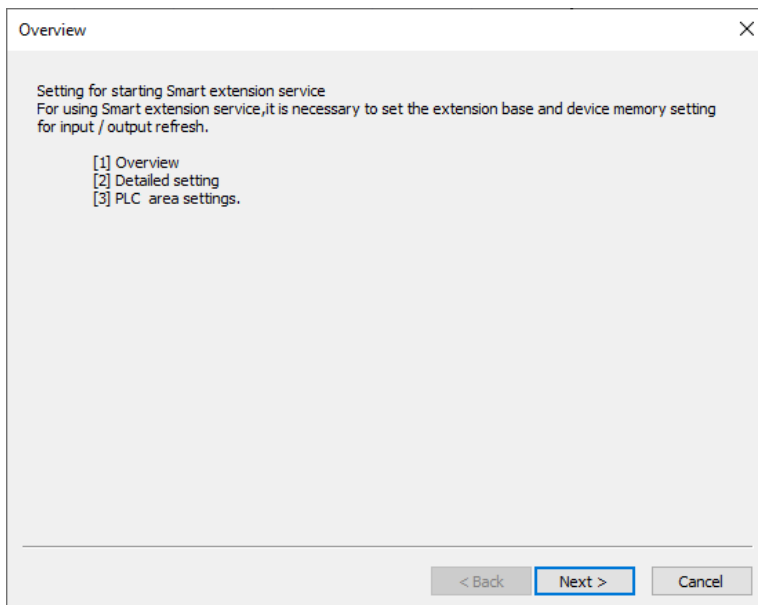

- (3) If you select "Next" in the [Overview] window of the Smart Extension Wizard, the [Details] window appears. Smart extension service setting such as communication device adding and setting and PLC area setting can be performed. However, I / O parameter setting must be made after setting communication device.

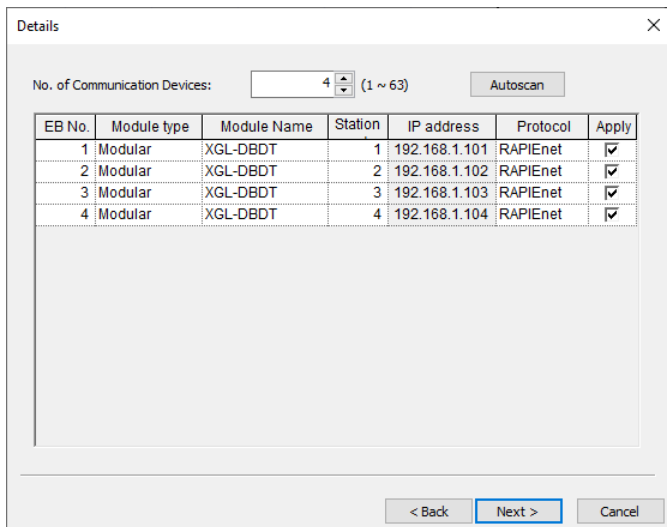

- (4) If you do not want to add the Smart Extension service without using the Smart extension wizard, simply select “Cancel” in the [Overview] window of the Smart extension wizard to register the Smart extension service.
- (5) After setting each item in [Details] or performing “Autoscan”, select the following. In order to proceed with “Auto Scan”, it must be in [Online]→[Connect].

Item	Contents																		
No. of Communication Devices	Set the number of Communication devices to be added to the Smart extension service.																		
Auto scan	Add connected Communication devices and specify connection information automatically. - Only available online.																		
EB No.	Specify the Extension Base (EB) number of the communication device to add.																		
Module type	Specifies the module type of the Communication device to be added. - For the module type, refer to the Communication Device User's Manual.																		
Module Name	Specifies the module name of the Communication device to be added. - For the module Name, refer to the Communication Device User's Manual.																		
Station No	Specifies the station number of the Communication device to be added. - The station number range is 0 ~ 220. - Setting station number method, refer to the Communication device User's Manual.																		
IP Address	Specifies the IP Assigns the Communication device to be added. For the IP setting, refer to the Communication device User's Manual.																		
Protocol	Specifies the connecting protocol of the communication device to be added. Available protocol information according to RAPIEnet setting of master and Communication device is as follow																		
	<table border="1"> <thead> <tr> <th>RAPIEnet settings for Ethernet(Master)</th> <th>Communication device RAPIEnet settings</th> <th>Available protocol</th> </tr> </thead> <tbody> <tr> <td rowspan="2">Disable</td> <td>Disable</td> <td>EtherNet/IP</td> </tr> <tr> <td>RAPIEnet v2</td> <td>EtherNet/IP</td> </tr> <tr> <td rowspan="2">RAPIEnet v1</td> <td>Disable</td> <td>EtherNet/IP</td> </tr> <tr> <td>RAPIEnet v2</td> <td>EtherNet/IP</td> </tr> <tr> <td rowspan="2">RAPIEnet v2</td> <td>Disable</td> <td>EtherNet/IP</td> </tr> <tr> <td>RAPIEnet v2</td> <td>RAPIEnet EtherNet/IP</td> </tr> </tbody> </table>	RAPIEnet settings for Ethernet(Master)	Communication device RAPIEnet settings	Available protocol	Disable	Disable	EtherNet/IP	RAPIEnet v2	EtherNet/IP	RAPIEnet v1	Disable	EtherNet/IP	RAPIEnet v2	EtherNet/IP	RAPIEnet v2	Disable	EtherNet/IP	RAPIEnet v2	RAPIEnet EtherNet/IP
	RAPIEnet settings for Ethernet(Master)	Communication device RAPIEnet settings	Available protocol																
	Disable	Disable	EtherNet/IP																
		RAPIEnet v2	EtherNet/IP																
	RAPIEnet v1	Disable	EtherNet/IP																
RAPIEnet v2		EtherNet/IP																	
RAPIEnet v2	Disable	EtherNet/IP																	
	RAPIEnet v2	RAPIEnet EtherNet/IP																	
Apply	Check the application box of the communication device that will store the connection information.																		

(6) In [PLC area setting] window, memory setting for 'Input / Output Variable' and 'Enables EB/Slot Diagnostic variable' is available. The address and size are automatically changed according to the communication device added in the advanced detailed settings. (However, the memory area setting counts Smart extension service as the highest priority. An area that overlaps with the memory area used by other services may occur.) When setting are finished, select 'Finish'.

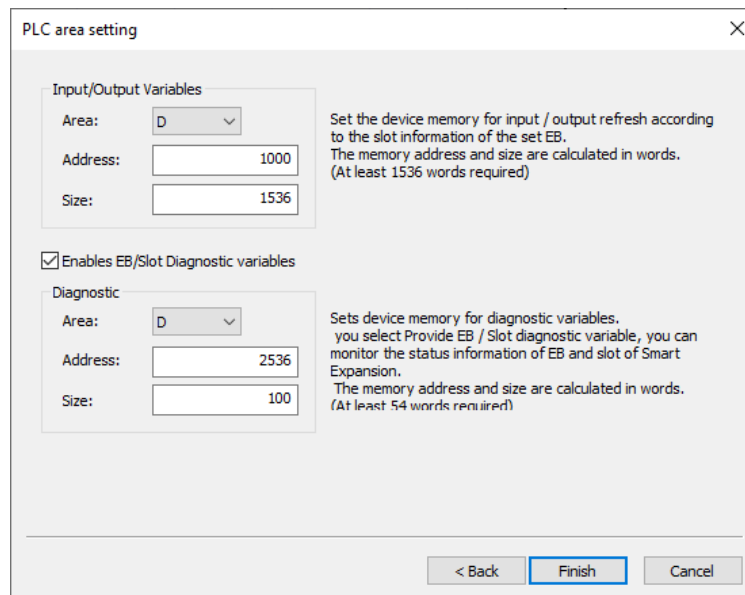

Item	Contents	
Input/Output Variables	Area	Set the memory area of the master to map the input / output variables of the communication device. - Select between P / M / D (XGK) and I / Q / M / W (XGI) areas.
	Address	Set the memory start address of the master to map the input / output variables of the communication device.
	Size	Set the memory area's size of the master to map the input / output variables of the communication device. -The Extension driver (XGL-DBDx) requires 384 words per unit. - The Smart I/O expansion (XGL-BSSRx) requires 256 words per unit. - The Smart I/O block (Digital) requires 4 words per unit. - The Smart I/O block (Analog) requires 32 words per unit.
Enables EB/Slot Diagnostic variables	Enable /Disable the use of EB/Slot Diagnostic variables. (System diagnostic variables are always provided regardless of the setting.)	
Diagnostic variables	Area	Set the memory area of the master to map the diagnostic variables of the communication device. - Select between P / M / D (XGK) and I / Q / M / W (XGI) areas.
	Address	Set the memory start address of the master to map the Diagnostic variables of the Communication device.
	Size	Set the memory area's size of the master to map the Diagnostic variables of the communication device. - The basic diagnostic variable of Smart extension service requires 22 words. - 8 words per 1 unit of communication device are required.

(7) To add a communication device, right-click [Smart Extension] and select [Add Item] → [Add Communication Device] or double-click New under Smart Extension in the project window.

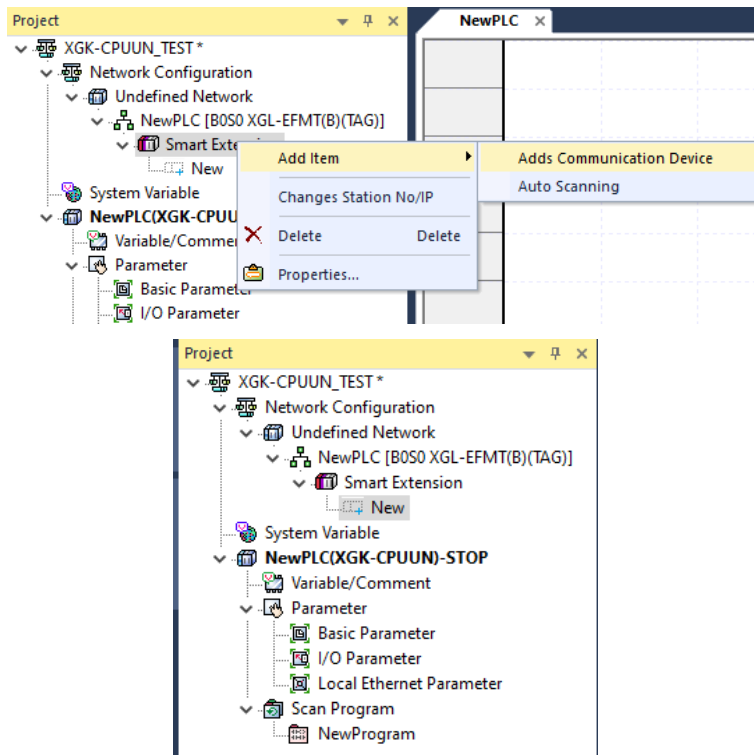

(8) You can add the communication device of the Smart Extension Service by specifying the connection information on the Connection tab of the Add Communication Device window and selecting 'OK'.

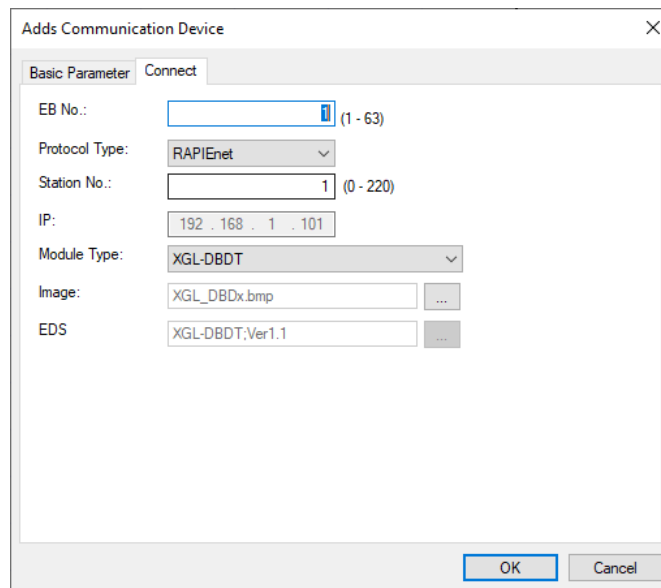

Item	Content																		
EB No.	Specify the Extension Base (EB) number of the Communication device to add.																		
Protocol type	Specifies the connecting protocol of the communication device to be added. Available protocol information according to RAPIEnet setting of master and Communication device is as follow																		
	<table border="1"> <thead> <tr> <th>RAPIEnet settings for Ethernet(Master)</th> <th>Communication device RAPIEnet settings</th> <th>Available protocol</th> </tr> </thead> <tbody> <tr> <td rowspan="2">Disable</td> <td>Disable</td> <td>EtherNet/IP</td> </tr> <tr> <td>RAPIEnet v2</td> <td>EtherNet/IP</td> </tr> <tr> <td rowspan="2">RAPIEnet v1</td> <td>Disable</td> <td>EtherNet/IP</td> </tr> <tr> <td>RAPIEnet v2</td> <td>EtherNet/IP</td> </tr> <tr> <td rowspan="2">RAPIEnet v2</td> <td>Disable</td> <td>EtherNet/IP</td> </tr> <tr> <td>RAPIEnet v2</td> <td>RAPIEnet EtherNet/IP</td> </tr> </tbody> </table>	RAPIEnet settings for Ethernet(Master)	Communication device RAPIEnet settings	Available protocol	Disable	Disable	EtherNet/IP	RAPIEnet v2	EtherNet/IP	RAPIEnet v1	Disable	EtherNet/IP	RAPIEnet v2	EtherNet/IP	RAPIEnet v2	Disable	EtherNet/IP	RAPIEnet v2	RAPIEnet EtherNet/IP
	RAPIEnet settings for Ethernet(Master)	Communication device RAPIEnet settings	Available protocol																
	Disable	Disable	EtherNet/IP																
		RAPIEnet v2	EtherNet/IP																
	RAPIEnet v1	Disable	EtherNet/IP																
		RAPIEnet v2	EtherNet/IP																
RAPIEnet v2	Disable	EtherNet/IP																	
	RAPIEnet v2	RAPIEnet EtherNet/IP																	
Station No	Specifies the station number of the Communication device to be added. - The station number range of the Communication device is 0 ~ 220. - Setting method, refer to the Communication Device User's Manual.																		
IP	Specifies the IP Assigns the Communication device to be added. - Setting method, refer to the Communication Device User's Manual.																		
Module type	Specifies the module type of the communication device to be added. - For the module Type, refer to the Communication Device User's Manual.																		
image	Select the image of the communication device. - Use the desired photo file as the image of the communication device. - This image is only used in the 'Configure Communication Device Connection' function.																		
EDS information	Select the EDS information of the communication device. - EDS information is automatically assigned when adding a communication device and cannot be modified.																		

### 4.2.3 Smart Extension master setting

In the Smart expansion master setting, the master setting, PLC area setting and Communication device operation setting can be performed. When a Communication device is added using the Smart Expansion Window or Autoscanner, the start address and size of the input / output variables and diagnostic variables in the PLC area settings are automatically set up for the added Communication device.

However, check that there is no overlapping memory area with other services other than the Smart Extension service.

- (1) Double-click [Smart Extension] added in the project window with the left mouse button.

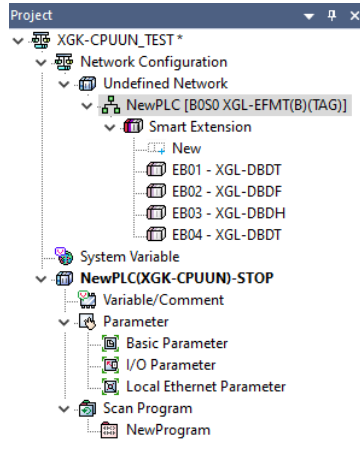

- (2) Select "Master Setting" in the Smart Extension Tree to enter the master setting and PLC area setting items.

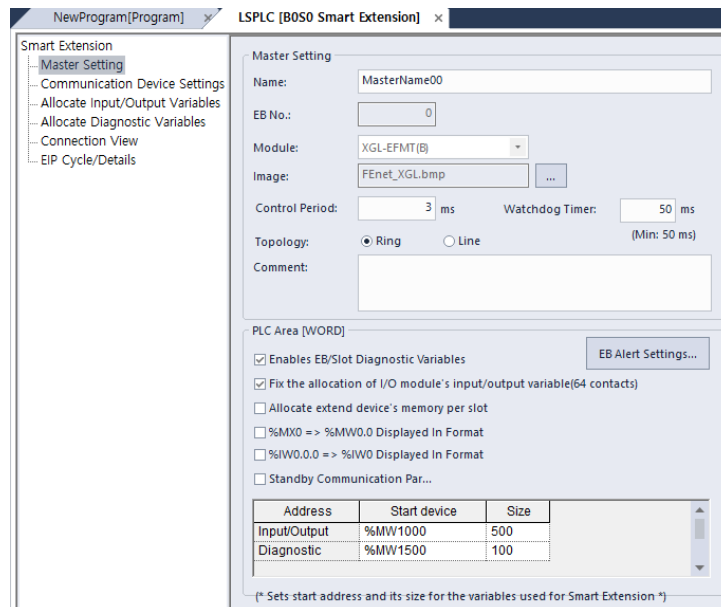

	Item	Contents
Master Setting	Name	Set the name of the Smart Expansion master module.
	EB No.	Set the EB number of the Smart Expansion master module. (Default: 0 Cannot be modified)
	Module type	Set the type of the Smart Expansion master module. (Displays the communication module type.)
	image	Set the image of the Smart Expansion master module.
	Control Period	Set the Control Frequency of the Smart Expansion master module. - The Control Frequency means the communication cycle between the expansion master (Ethernet) module and the communication device (Expansion driver, Smart I / O expansion, Smart I / O block).
	Watchdog timer	Set the time that frame of communication device should be received according to Control Frequency. If the frame of communication device is not received in the Control Frequency, communication error occurs.
	Topology	Sets the topology information to be compared in RAPIEnet autoscan.
	Description	Make comments related to the Smart Expansion Master.
PLC area setting	EB Alert Settings	Set the items that activate the extension EB warning. - Extension EB configuration error - Dropping error during extension EB operation - Extension EB refresh response timeout - Receiving extension EB CRC error frame - Module installation error in EB during extension EB operation - Fuse error in module installed in extension EB
	Enables EB/Slot Diagnostic variables	Check "Enable EB / Slot Diagnostic variables" when using EB / Slot diagnostic variables.
	Fixed allocation of I / O module input/output variables(64 points)	The number of Smart I / O block type contact points and the number of I / O module contacts added to the Smart I / O extension type is fixed to 64 points, or it is provided with a function to allocate the number of mounted I / O modules gradually. (At least 32 points)
	Memory allocation by slot of expansion device	It provides the function of allocating the memory of the Smart I / O block type and the Smart I / O expansion type as a base unit or a slot unit.
	Display % MX0 =>% MW0.0	When it is created as an XGI/R project, it provides the function of displaying the BOOL type in WORD form in the input / output variable allocation window and the diagnosis variable allocation window of the Smart I / O expansion type.
	%IW0.0.0 => %IW0 Displayed in Format	When created as an XGI/R project, it provides the function to change I, Q direct variable expressions for the extended base.
	Standby Communication participation	When created as an XGR project, configure whether the standby module participates in communication.
	Input/Output Variables	Setting the input / output variable of the Communication device. (The size of the variable is the starting address plus the size.)
	Diagnostic variables	Set Smart Expansion diagnostic variables. (The size of the variable is the starting address plus the size.)

Notes

In case of Control Frequency, set more than 3 times of CPU scan cycle.

(3) Address assignment to input / output modules

Address assignment to input / output modules has a function that can be individually set. For modules with inputs and outputs, each can be set by specifying it in the form of 'input address / output address'. It is available only when 'Memory allocation by slot of expansion device' is selected.

[When set to default]

Format: <span>Decimal</span> <span>Variable Setting</span> <span>Synchronize</span>								
	EB No.	Station No/IP	Slot number	Variable name	Type	Device	Monitor value	Comment
1	EB01	1	Slot00					XGF-AV8A (A/D Voltage Inp Type(8 Channels))
2				_0000_EB01_0000_ERR	BOOL	%MX16000		Analog Input Module: Error
3				_0000_EB01_0000_RDY	BOOL	%MX16015		Analog Input Module: Read
4				_0000_EB01_0000_CH0_ACT	BOOL	%MX16016		Analog Input Module: CH0.
5				_0000_EB01_0000_CH1_ACT	BOOL	%MX16017		Analog Input Module: CH1.
6				_0000_EB01_0000_CH2_ACT	BOOL	%MX16018		Analog Input Module: CH2.
7				_0000_EB01_0000_CH3_ACT	BOOL	%MX16019		Analog Input Module: CH3.
8				_0000_EB01_0000_CH4_ACT	BOOL	%MX16020		Analog Input Module: CH4.

[When input is set to% MW1000 and output is set to% MW2000]

Format: <span>Decimal</span> <span>Variable Setting</span> <span>Synchronize</span>								
	Station No/IP	Slot number	Variable name	Type	Device	Monitor value	Comment	
1	1	Slot00			%MW1000		XGF-AV8A (A/D Voltage Input Type(8 Channels))	
2			_0000_EB01_0000_ERR	BOOL	%MX16000		Analog Input Module: Error Flag	
3			_0000_EB01_0000_RDY	BOOL	%MX16015		Analog Input Module: Ready Flag	
4			_0000_EB01_0000_CH0_ACT	BOOL	%MX16016		Analog Input Module: CH0 Activatio	
5			_0000_EB01_0000_CH1_ACT	BOOL	%MX16017		Analog Input Module: CH1 Activatio	
6			_0000_EB01_0000_CH2_ACT	BOOL	%MX16018		Analog Input Module: CH2 Activatio	
7			_0000_EB01_0000_CH3_ACT	BOOL	%MX16019		Analog Input Module: CH3 Activatio	
8			_0000_EB01_0000_CH4_ACT	BOOL	%MX16020		Analog Input Module: CH4 Activatio	

(4) Select "Communication Device Settings" from the Smart extension tree to set the Communication device operation setting.

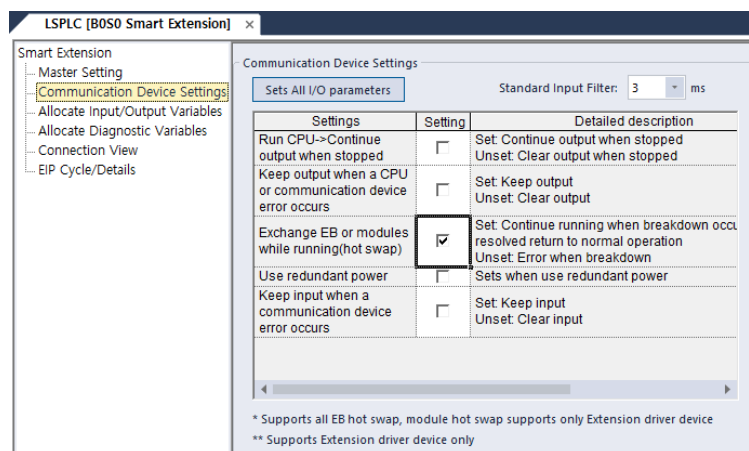

Item		Contents
Communication Device Settings	Sets all I/O parameters	Set all I / O parameters of the PLC equipped with the Communication device. Detailed setting is as follows.
	Standard input filter	Set standard input filter value of input module installed in Communication device. If you change the value, the filter value of the input modules installed in the Communication device is changed to the set value.
	Hold output when converting run-> stop.	When the CPU mode is changed from run to stop, this is the setting for the output of the output module installed in the Communication device in Smart Extension. - setting: Hold output - Non-setting: Clear output
	Hold output when CPU or Communication device error occurs	When an error occurs in the CPU or Communication device, it is the setting for the output of the output module installed in the Communication device in the Smart extension. - Setting: Hold output when an error occurs - Non-setting: Clear output when an error occurs
	EB or module swap during operation (hot swap)	Setting to allow the exchange of EB (PLC with communication device) or module mounted in EB during operation. - Setting: Continue operation when a fault occurs and normal operation when a fault is restored - Non-setting: Change to error mode when a fault occurs
	Use redundant power	Check if the redundant power base is used for the PLC equipped with the communication device. If you use this option, check various logs of power redundancy base and get LED information according to the operation. - Setting: Use redundant power base - Non-setting: Use single power base
	Maintain input when a communication device error occurs	This is a setting for maintaining input data values in smart expansion when an error occurs in a communication device. - Settings: Maintain input data when an error occurs - Not set: Clear input data when an error occurs

(5) Sets all I/O parameters

Select [Sets all I/O parameters] of Communication device operation setting during master setting.

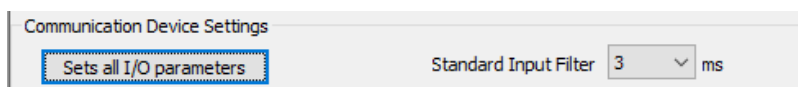

Select the module to which the parameter will be applied in batch, set the parameter and select 'Apply

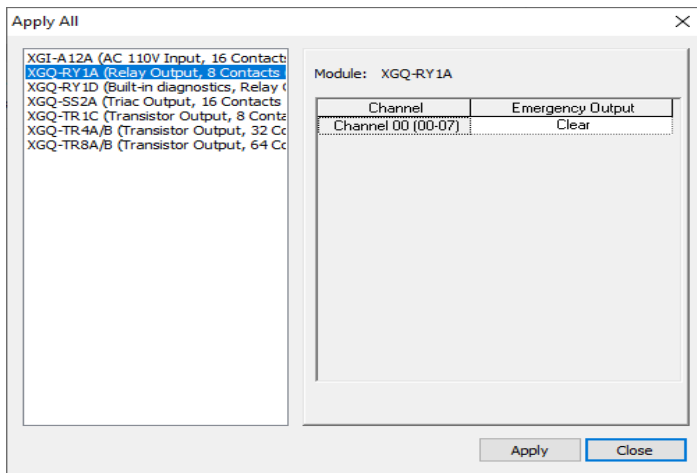

Check the location (Smart Extension EB, BASE, SLOT) of the module to apply in batch and select 'OK'  
 (It is not applicable to each module individually, but the setting values are applied to all modules at once.)

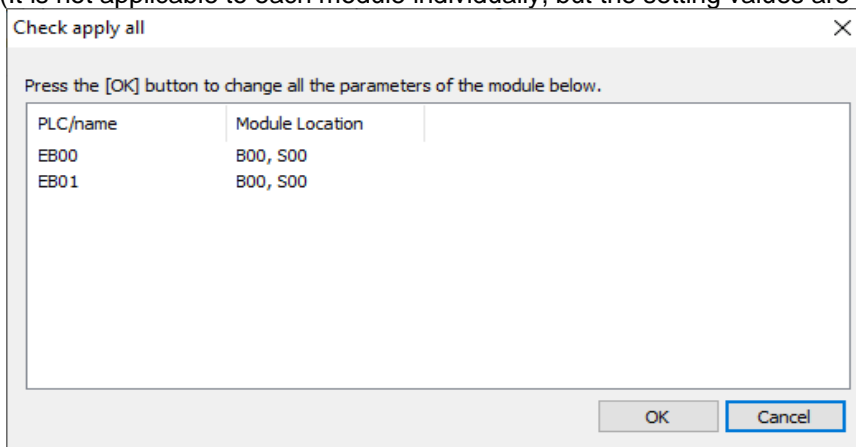

**Notes**

Use with caution because the set values of the same module in the Smart Expansion System are set to be the same.

- (6) Select [Smart Extension] in the Project window and double-click to select [Allocate Input/Output Variables] in the Smart Extension tree. This function can be used like the same PLC system by mapping input / output device of PLC system equipped with Communication device to device memory of CPU module equipped with Ethernet (FEnet) module

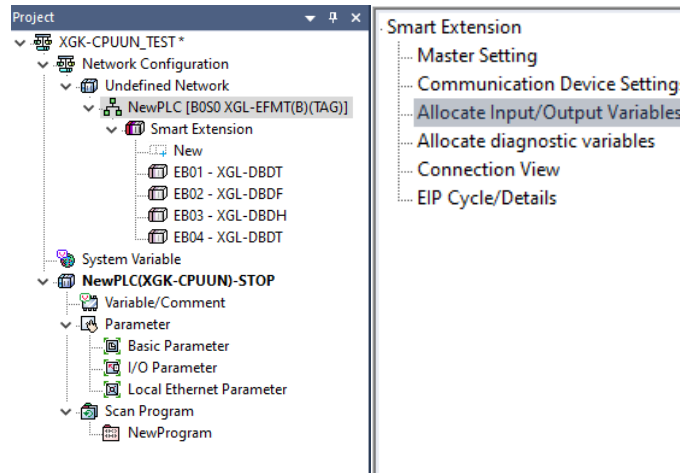

(7) In the [Allocate Input/Output Variables] window, check the input / output devices of the PLCs equipped with each Communication device. At this time, select “Register Variable” to register the device as a variable.

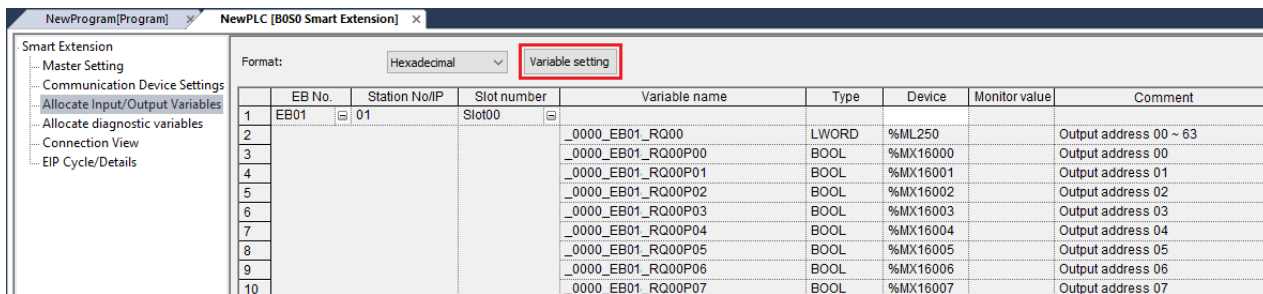

(8) If you double-click [Variable / Comment] in the [Project] window, you can see that the Smart Extension input / output variable is registered as the CPU variable of the master.

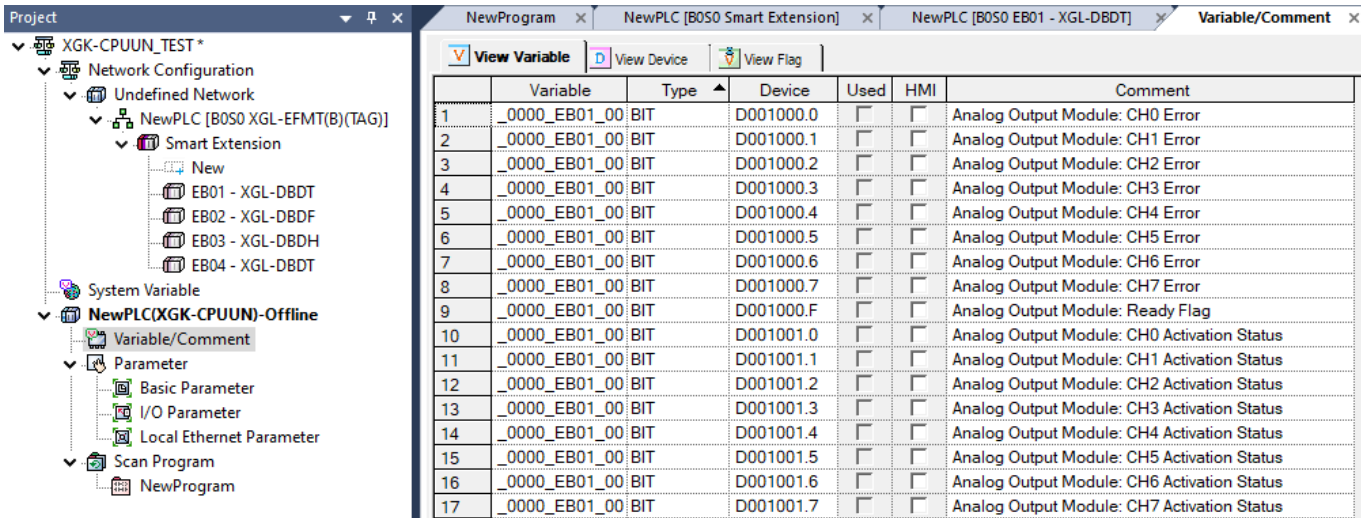

**Notes**

The variable name rules for input / output variables are as follows

(1) I/O Module

- \_BBSS\_EBXX\_RQxxPyy: Base number on which the master module is mounted
- \_BBSS\_EBXX\_RQxxPyy: Slot number on which the master module is mounted
- \_BBSS\_EBXX\_RQxxPyy: EB number of the Communication device
- \_BBSS\_EBXX\_RQxxPyy: Input / Output division(RQ:Output / RI: Input)
- \_BBSS\_EBXX\_RQxxPyy: Slot number of the module mounted on the Communication device
- \_BBSS\_EBXX\_RQxxPyy: Contact No.

(2) Special module

- \_BBSS\_EBXX\_bsss\_CH0\_ACT: Base number on which the master module is mounted
- \_BBSS\_EBXX\_bsss\_CH0\_ACT: Slot number on which the master module is mounted
- \_BBSS\_EBXX\_bsss\_CH0\_ACT: EB number of the Communication device
- \_BBSS\_EBXX\_bsss\_CH0\_ACT: Base number of the module mounted on the Communication device
- \_BBSS\_EBXX\_bsss\_CH0\_ACT: Slot number of the module mounted on the Communication device
- \_BBSS\_EBXX\_bsss\_CH0\_ACT: Variable type

(9) Select [Smart Extension] in the [Project] window and double-click to display [Allocate diagnostic variables] in the Smart Extension tree.

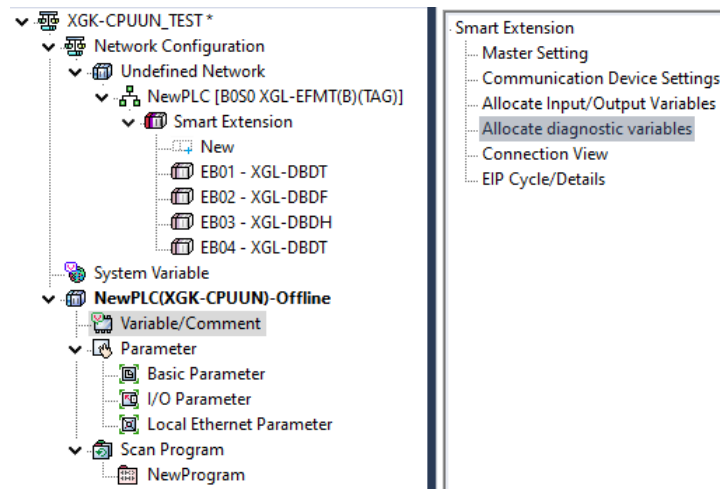

(10) Diagnostic variables are as follows

Classification		Item	Type and Size	Contents		
System diag		<u>_BBSS_STATUS_CHG_CNT</u>	1Word(2Byte)	Number of Smart Expansion Network Status changes 1) When using RAPIenet V2 and changing the network topology, count increases. 2) When changing error status or warning status by smart extension EB, count increases		
		<u>_BBSS_SCAN_MAX</u>	1Word(2Byte)	Smart Expansion Maximum Scan time(100 $\mu$ s) (If all the protocol types of EB participating in the service are EtherNet/IP, the value of ' <u>_BBSS_SCAN_MAX</u> ' is not valid.)		
		<u>_BBSS_SCAN_MIN</u>	1Word(2Byte)	Smart Expansion Minimum Scan time(100 $\mu$ s) (If all the protocol types of EB participating in the service are EtherNet/IP, the value of ' <u>_BBSS_SCAN_MIN</u> ' is not valid.)		
		<u>_BBSS_SCAN_CUR</u>	1Word(2Byte)	Smart Expansion Current Scan time(100 $\mu$ s) (If all the protocol types of EB participating in the service are EtherNet/IP, the value of ' <u>_BBSS_SCAN_CUR</u> ' is not valid.)		
		<u>_BBSS_SYSTEM_ER</u>	1Bit	Smart Extension overall EB error		
		<u>_BBSS_SYSTEM_WAR</u>	1Bit	Smart Extension part EB error		
		<u>_BBSS_EB_DEER</u>	1Bit	EB detached while operating Smart Extension		
		<u>_BBSS_EB_BASE_INFO_ER</u>	1Bit	Smart Extension base information error		
		<u>_BBSS_IO_TYER</u>	1Bit	Smart Extension I/O Type error		
		<u>_BBSS_IO_DEER</u>	1Bit	Smart Extension I/O detached error		
		<u>_BBSS_FUSE_ER</u>	1Bit	Smart Extension I/O Fuse error		
		<u>_BBSS_REF_TIME_OUT</u>	1Bit	Smart Extension I/O refresh time out (For V9.10 and above, On when it occurs twice in a row)		
		<u>_BBSS_EB_CRC_ER</u>	1Bit	Smart Extension EB CRC Error Frame Receive		
		<u>_BBSS_TAG_ER</u>	1Bit	Smart Extension tag inconsistency error		
		<u>_BBSS_EB_CFG_ER</u>	1Bit	Smart Extension EB configuration error		
		<u>_BBSS_EB_DETACH_WAR</u>	1Bit	EB detached warning while operating Smart Extension operation(Hot swap On)		
		<u>_BBSS_IO_DETACH_WAR</u>	1Bit	IO detached warning while operating Smart Extension operation(Hot swap On)		
		<u>_BBSS_FUSE_WAR</u>	1Bit	FUSE warning while operating Smart Extension operation(Hot swap On)		
		<u>_BBSS_EIP_BLOCK_SVC_ER</u>	1Bit	All EtherNet/IP block services are error		
		<u>_BBSS_EIP_BLOCK_SVC_WAR</u>	1Bit	Some of EtherNet/IP blocks is(are) error		
		<u>_BBSS_STANDBY_COMM_EN</u>	1Bit	Standby Communication Participation		
		<u>_BBSS_SATATUS_CHG_CNT_CLR</u>	1Bit	Smart Expansion Network Status change number initialization		
		<u>_BBSS_REF_TIME_OUT_CLR</u>	1Bit	Smart Extension refresh time out initialization		
		<u>_BBSS_EB_CRC_ER_CLR</u>	1Bit	Smart Extension EB CRC Error Frame receive initialization		
		<u>_BBSS_SCAN_CLEAR</u>	1Bit	Smart Extension scan information initialization		
		<u>_BBSS_FLAG_CLEAR</u>	1Bit	Smart Extension flag information initialization		
		EB Diagnostic variables	Diagnostic variables of EB status.	<u>_BBSS_EB_ER</u>	Bit Array(0~64)	Error Status by Smart Extension EB
				<u>_BBSS_EB_WAR</u>	Bit Array(0~64)	Warning Status by Smart Extension EB
				<u>_BBSS_EBXX_CFG_ER</u>	1Bit	EB configuration error
				<u>_BBSS_EBXX_DEER</u>	1Bit	Detached while operating EB
<u>_BBSS_EBXX_REF_TIME_OUT</u>	1Bit			EB refresh response timeout		
<u>_BBSS_EBXX_P1_CRC_ER</u>	1Bit			Receive CRC error frame at EB port 1		
<u>_BBSS_EBXX_P2_CRC_ER</u>	1Bit			Receive CRC error frame at EB port 2		
<u>_BBSS_EBXX_BASE_INFO_ER</u>	1Bit			EB Base information error		

Diagnostic variables by slot	<u>_BBSS_EBXX_IO_TYER</u>	1Bit	EB I/O type error
	<u>_BBSS_EBXX_IO_DEER</u>	1Bit	EB I/O detached error
	<u>_BBSS_EBXX_FUSE_ER</u>	1Bit	EB Fuse error
	<u>_BBSS_EBXX_SYY_IO_TYER</u>	1Bit	Module I/O type error
	<u>_BBSS_EBXX_SYY_IO_DEER</u>	1Bit	Module I/O detached error
	<u>_BBSS_EBXX_SYY_FUSE_ER</u>	1Bit	Module Fuse error
	<u>_BBSS_EBXX_SYY_SVC_NDR</u>	1Bit	Communication service New Data Ready (EtherNet / IP block service only)
	<u>_BBSS_EBXX_SYY_SVC_ER</u>	1Bit	Communication Service error (EtherNet / IP block service only)

**Notes**

The variable name rules for diagnostic variables are as follows

(1) System diagnostic variables

- \_BBSS\_STATUS\_CHG\_CNT: Base number on which the master module is mounted
- \_BBSS\_STATUS\_CHG\_CNT: Slot number on which the master module is mounted
- \_BBSS\_STATUS\_CHG\_CNT: variable type

(2) EB Diagnostic variables

- \_BBSS\_EBXX\_CFG\_ER: Base number on which the master module is mounted
- \_BBSS\_EBXX\_CFG\_ER: Slot number on which the master module is mounted
- \_BBSS\_EBXX\_CFG\_ER: EB number of the Communication device
- \_BBSS\_EBXX\_CFG\_ER: variable type

(3) Slot Diagnostic variables

- \_BBSS\_EBXX\_SYY\_IO\_TYER: Base number on which the master module is mounted
- \_BBSS\_EBXX\_SYY\_IO\_TYER: Slot number on which the master module is mounted
- \_BBSS\_EBXX\_SYY\_IO\_TYER: EB number of the Communication device
- \_BBSS\_EBXX\_SYY\_IO\_TYER: Slot number of the module mounted on the Communication device
- \_BBSS\_EBXX\_SYY\_IO\_TYER: variable type

When \_BBSS\_EBXX\_P1\_CRC\_ER is set, it means CRC error frame is received in the corresponding EB port. Check the communication cable, noise in the communication environment, and cable connection.

(11) Select [Smart Extension] in the [Project] window and double-click to select [Connection View] in the Smart Extension tree. Smart Extension service provides Connection View function to check the configuration of connected Communication device. "Connection View" function allows to check the name, protocol, station number, IP and communication status of the currently connected Communication device and EIP module.

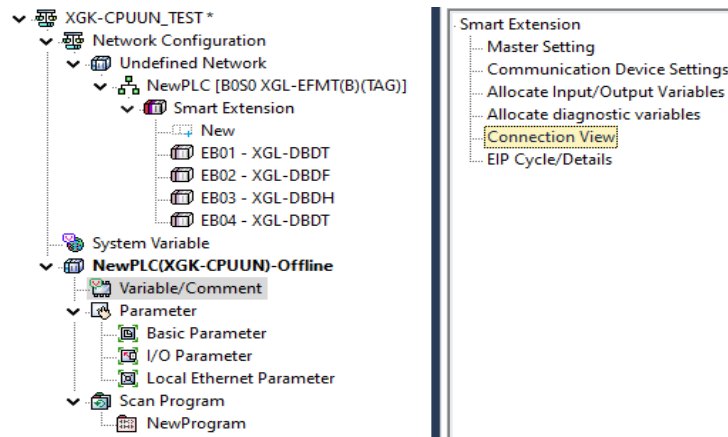

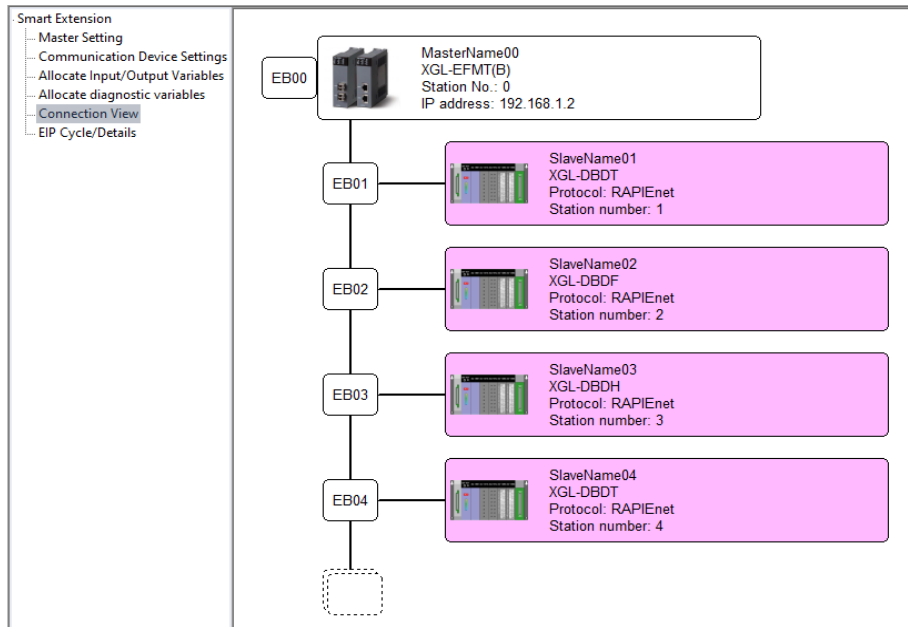

(12) Select [Smart Extension] in the [Project] window and double-click to select [EIP Cycle/Details] in the Smart Extension tree. In the EIP Cycle/Details, check the list of EIP clients currently configured. (EIP server list is not available.)

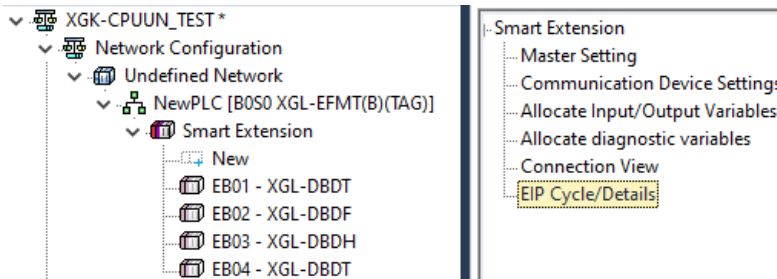

(13) Check the list and detailed settings of the EIP client in the EIP Cycle/Details window.

The screenshot shows the 'EIP Cycle/Details' window. On the left, the configuration menu is visible with 'EIP Cycle/Details' selected. The main area displays a table with the following columns:

Module kind	Operation mode	I/O type	Connection type	Function	Parameter contents	Conditional flag	Transmission period(ms)	Timeout	Data Type	Local tag

(14) RAPIenet autoscan topology change display function(V8.0 or higher)

This function displays the changed information on the screen when the topology information set by the user and the installed topology information are different in RAPIenet Auto Scan.

To set the topology information, you can set it in [Undefined Network]> [Smart Extension]> [Master Settings]> [Topology Configuration] in the project window.

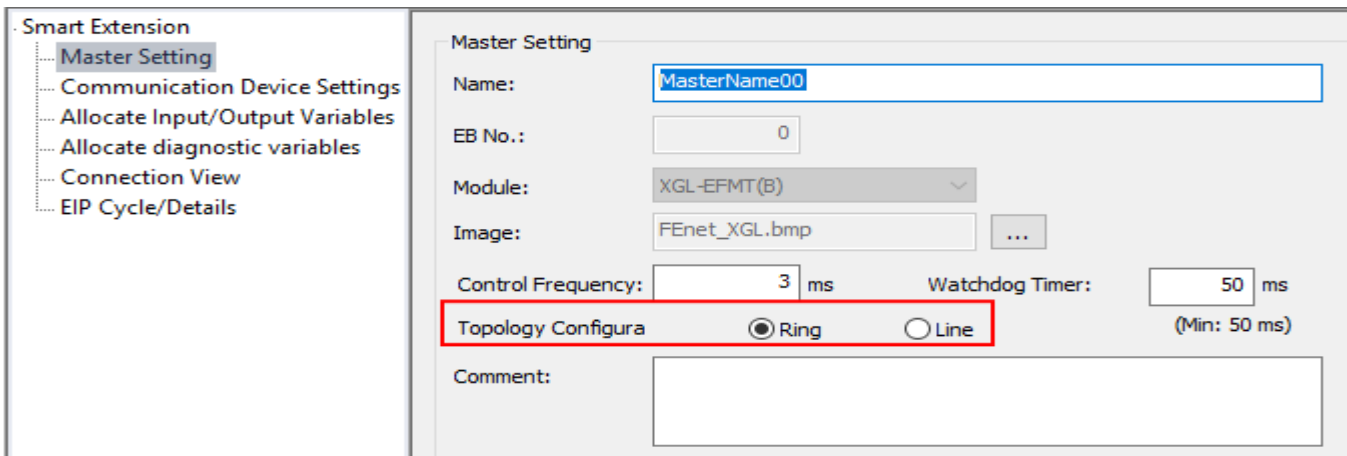
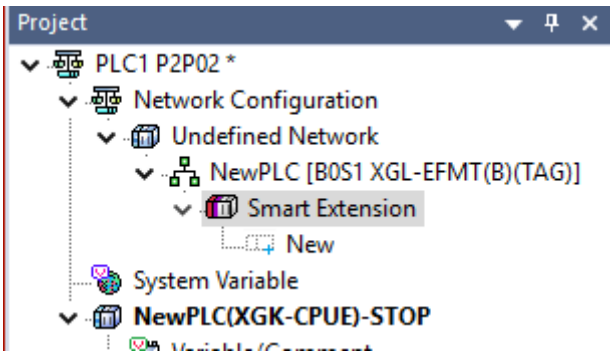

Executing RAPIenet autoscan in [Online]> Communication module setting and Diagnosis] and diagnosis> [System diagnosis].

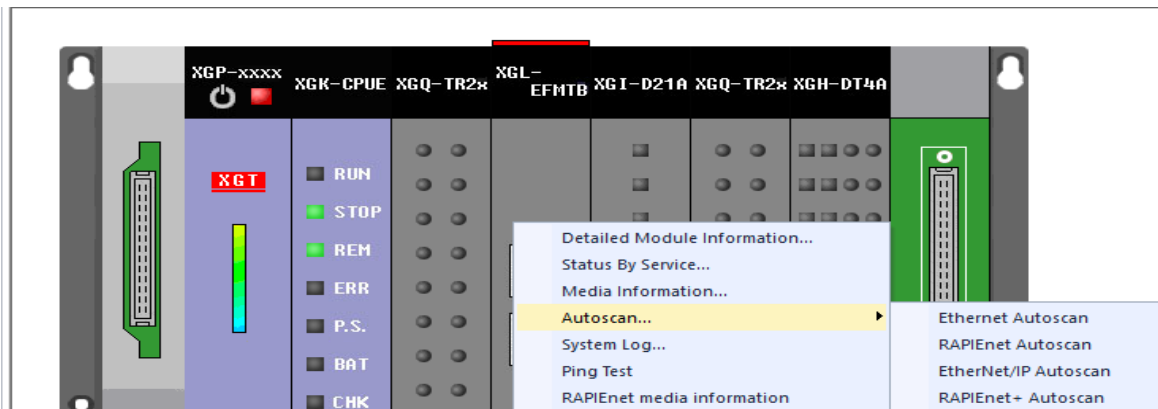

If setting topology information and the installed topology information is different, a red line indicates that the topology has been changed as shown below.



## Chapter 4 Smart Extension service

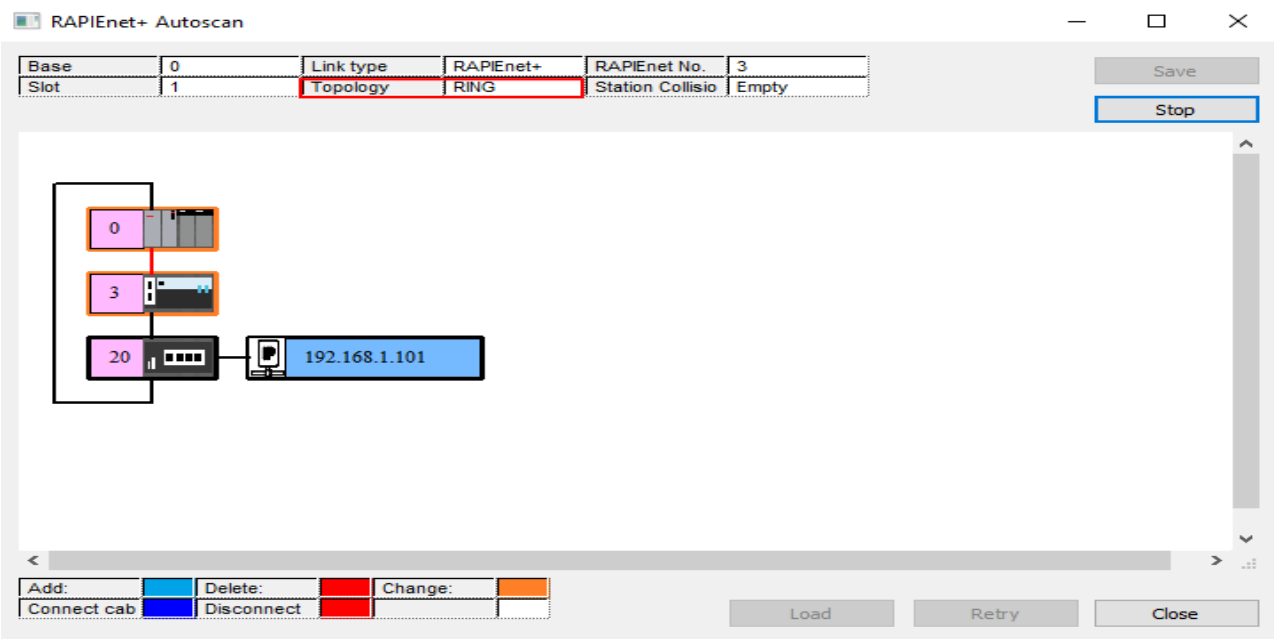

The opposite case is indicated by a blue line.

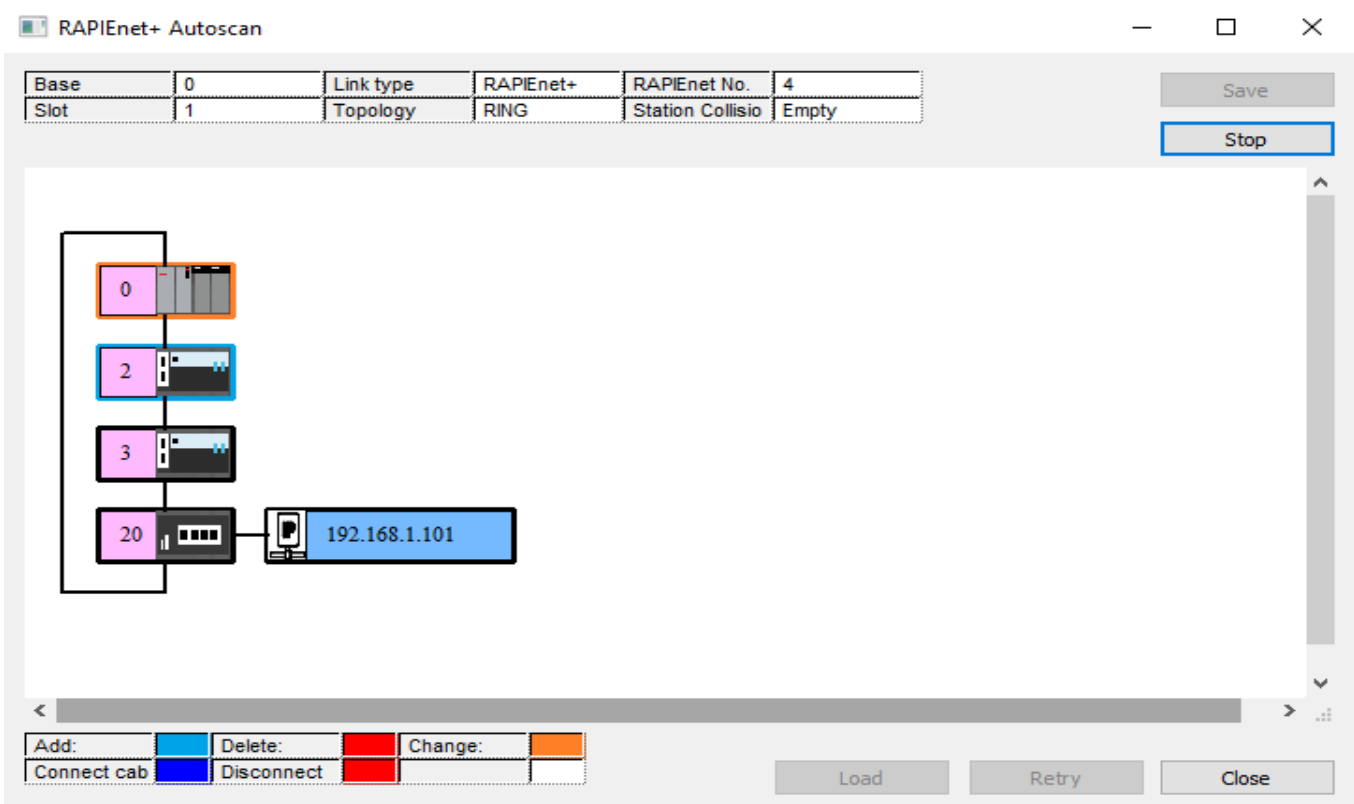

4.2.4 Communication device setting

Set up the Communication device remotely. However, remote setting of station number and IP address is impossible except for special cases.

(The station number and IP address of the communication device can be remotely set using the 'Station No./IP Change' function only when the station number switch of the Communication device is '00'.) Setting method, refer to the Communication Device User's Manual.

- (1) In the project window, select the [Smart Extension]→ Extension driver and double-click it.

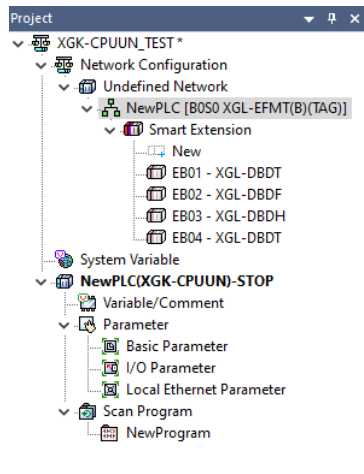

- (2) In [Basic Parameter] of the [Sets Communication Devices] tree, Set the name and operation setting of Communication device

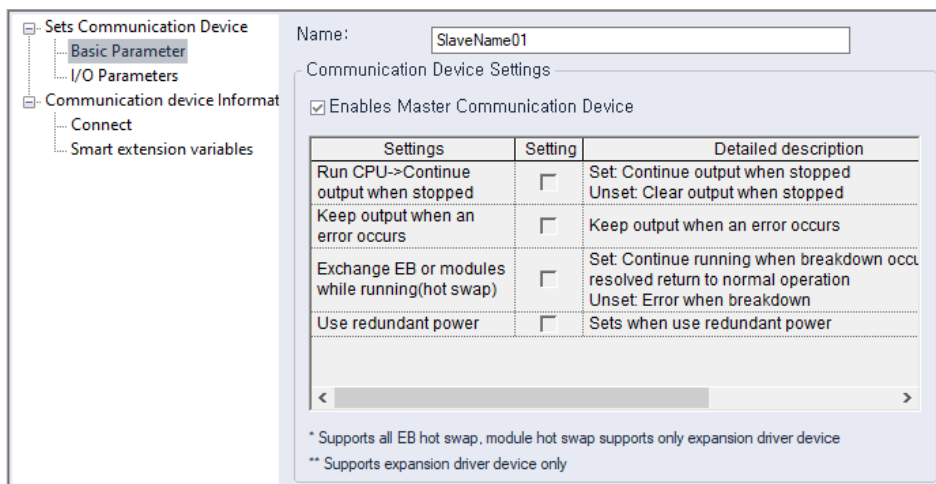

Item	Contents
Name	Set the name of the Communication Device.
Set the Communication device operation of the master	Check this if you want to automatically reflect the master set values as the Communication device operation set values.
Hold output when converting run-> stop.	When the CPU mode is changed from run to stop, this is the setting for the output of the output module installed in the Communication device in Smart Extension. - Setting: Hold output when switching from run to stop - Non-setting: Clear output when switching from run to stop
Hold output when CPU or communication device error occurs.	When an error occurs in the CPU or Communication device, it is the setting for the output of the output module installed in the Communication device in the

	Smart extension. - Setting: Hold output when an error occurs - Non-setting: Clear output when an error occurs
EB or module swap during operation (hot swap)	Setting to allow the exchange of EB (PLC with communication device) or module mounted in EB during operation. - Setting: Continue operation when a fault occurs and normal operation when a fault is restored - Non-setting: Change to error mode when a fault occurs
Use dual power base	Check if the dual power base is used for the PLC equipped with the communication device. If you use this option, check various logs of power redundancy base and get LED information according to the operation. - Setting: Use dual power base - Non-setting: Use single power base

(3) In [I / O Parameter] of [Communication device setting] tree, I / O parameter setting of PLC equipped with communication device can be set. When a communication device is added using auto scan, parameter information of the I / O module installed in the PLC is automatically set.

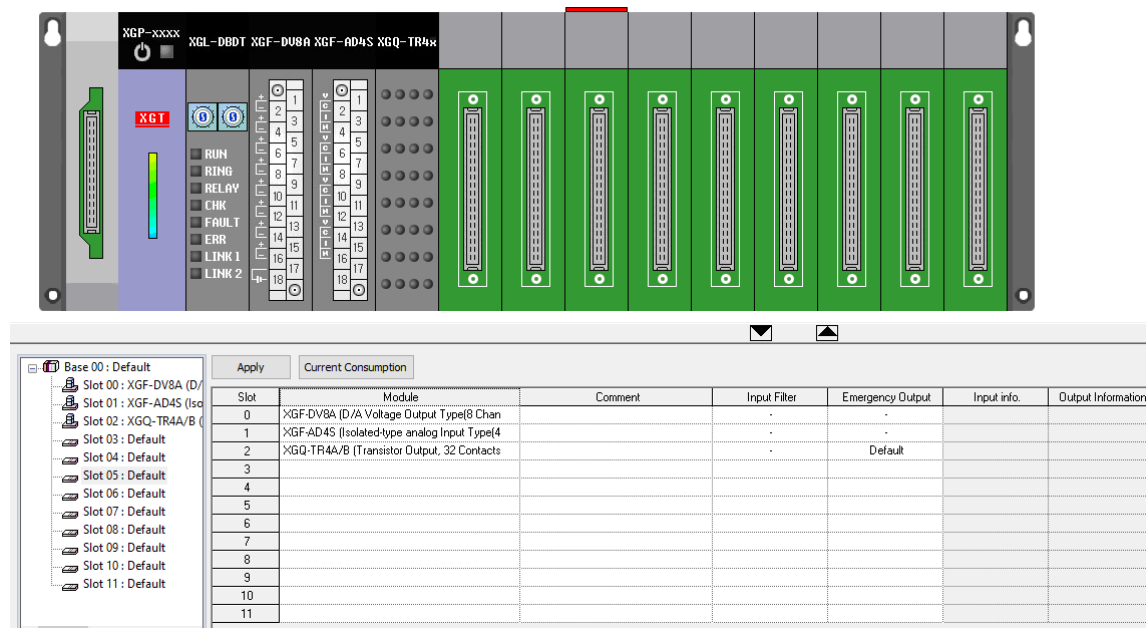

Item	Contents
Module	Select the module mounted on the communication device.
Description	write a comment - Select the comment cell you want to last with the left mouse button and create it. - The comment is not stored in the communication module.
Input filter	Select an input filter value. (Input module/input and output module)
Emergency output	Emergency output can be set. (Output module/input and output module)
Input information/Output information	The Communication device does not support the function of checking input information/ output information.

(4) In [Connect] of the [Sets Communication Devices] tree, check the connection information with the Communication device.

Please refer to 4.3.2 Smart Expansion Service for setting items.

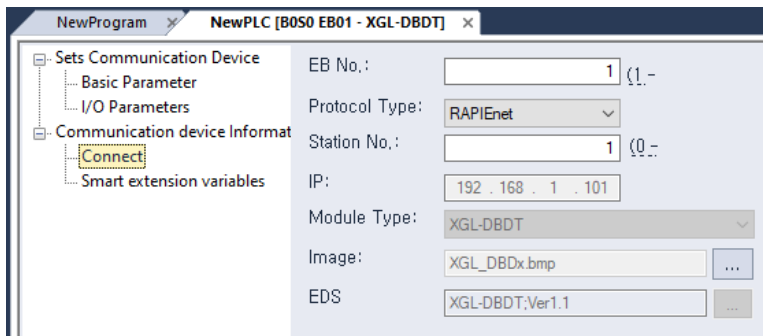

(5) In [Smart extension variables] of [Sets Communication Device] tree, check the module variable set in [I / O Parameters].

	Slot	Variable name	Type	Options	Comment
1	0				
2		_00_CH0_ERR	BIT	UB0.0	Analog Output Module: CH0 Error
3		_00_CH1_ERR	BIT	UB0.1	Analog Output Module: CH1 Error
4		_00_CH2_ERR	BIT	UB0.2	Analog Output Module: CH2 Error
5		_00_CH3_ERR	BIT	UB0.3	Analog Output Module: CH3 Error
6		_00_CH4_ERR	BIT	UB0.4	Analog Output Module: CH4 Error
7		_00_CH5_ERR	BIT	UB0.5	Analog Output Module: CH5 Error
8		_00_CH6_ERR	BIT	UB0.6	Analog Output Module: CH6 Error
9		_00_CH7_ERR	BIT	UB0.7	Analog Output Module: CH7 Error
10		_00_RDY	BIT	UB1.7	Analog Output Module: Ready Flag
11		_00_CH0_ACT	BIT	UB2.0	Analog Output Module: CH0 Activation Status
12		_00_CH1_ACT	BIT	UB2.1	Analog Output Module: CH1 Activation Status
13		_00_CH2_ACT	BIT	UB2.2	Analog Output Module: CH2 Activation Status
14		_00_CH3_ACT	BIT	UB2.3	Analog Output Module: CH3 Activation Status
15		_00_CH4_ACT	BIT	UB2.4	Analog Output Module: CH4 Activation Status
16		_00_CH5_ACT	BIT	UB2.5	Analog Output Module: CH5 Activation Status
17		_00_CH6_ACT	BIT	UB2.6	Analog Output Module: CH6 Activation Status
18		_00_CH7_ACT	BIT	UB2.7	Analog Output Module: CH7 Activation Status
19		_00_CH0_OUTE	BIT	UB4.0	Analog Output Module: CH0 Output Enable
20		_00_CH1_OUTE	BIT	UB4.1	Analog Output Module: CH1 Output Enable
21		_00_CH2_OUTE	BIT	UB4.2	Analog Output Module: CH2 Output Enable
22		_00_CH3_OUTE	BIT	UB4.3	Analog Output Module: CH3 Output Enable
23		_00_CH4_OUTE	BIT	UB4.4	Analog Output Module: CH4 Output Enable
24		_00_CH5_OUTE	BIT	UB4.5	Analog Output Module: CH5 Output Enable
25		_00_CH6_OUTE	BIT	UB4.6	Analog Output Module: CH6 Output Enable
26		_00_CH7_OUTE	BIT	UB4.7	Analog Output Module: CH7 Output Enable

**Notes**

- (1) In case of PLC system equipped with Communication device, base extension using extension cable is not supported.
- (2) The Expansion driver can be mounted in the CPU module slot of the main base. If it is installed in the expansion base slot, it will not be recognized and it will not operate.
- (3) Smart extension variable name rules by module are as follows.
  - I/O Module
    - \_RQxxPyy: Input / Output division(RQ:Output / RI: Input)
    - \_RQxxPyy: Slot number of the module mounted on the Communication device
    - \_RQxxPyy: contact No.
  - Special module
    - \_bbss\_CH0\_ACT: Base number of the module mounted on the Communication device
    - \_bbss\_CH0\_ACT: Slot number of the module mounted on the Communication device
    - \_bbss\_CH0\_ACT: Variable type

### 4.2.5 Smart Extension service setting Download

When the setting of the Smart Extension service is downloaded to the CPU module, the Communication device operates according to the setting value. (Downloading Smart Extension Service settings is only possible while online.)

- (1) Select [Online] → [Write].

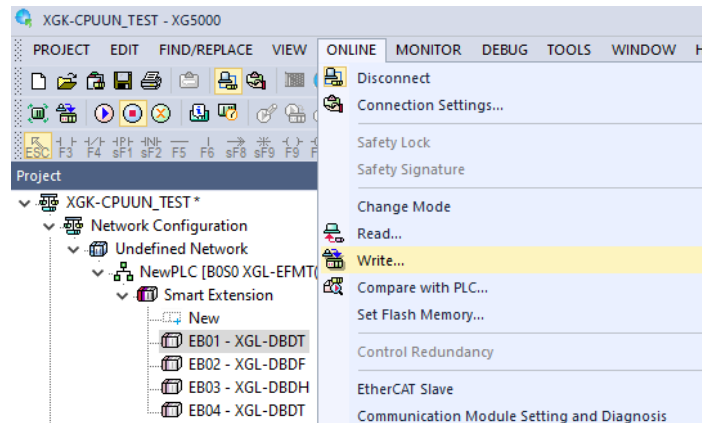

- (2) After that, the Ethernet (master) module and Communication device are immediately reflected the Smart expansion service setting value without the module reset. After that, the Ethernet (master) module and Communication device are immediately reflected the Smart expansion service setting value without the module reset.

When the module is exchanged using the Module Changing Wizard, the Smart expansion service parameter is not set automatically. Therefore, download the following items again with [Online]→[Write] of XG5000.

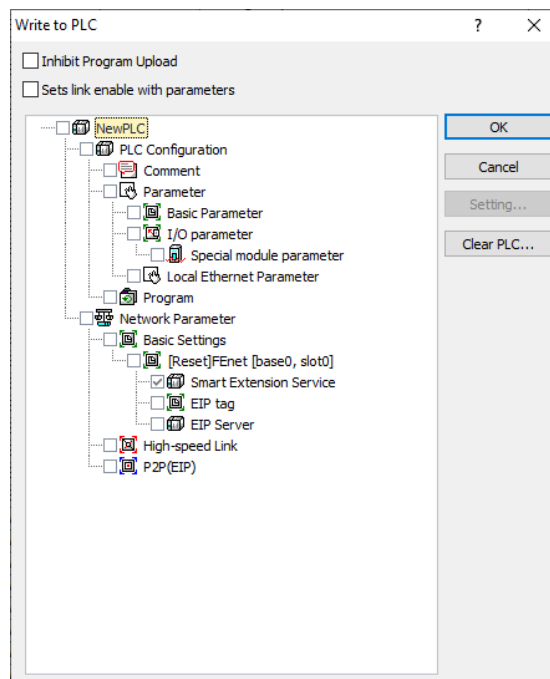

#### Notes

- (1) In case of slaves using EtherNet / IP protocol, EB dropout may occur when downloading 'Smart expansion' item setting. If EB or module change (hot swap) option is disabled during operation, slave module may not work due to EB dropout. At this time, in order to restore the service, refer to 4.3.6 Enabling Smart extension service to perform Smart extension service. (Disable → Enable)

4.2.6 Smart Extension Enable Services

Enable the service to use the Smart Extension service. Also, if you want to stop only the Smart extension service while the PLC service is running, disabling the Smart Extension service will only stop the Smart Extension service. (Setting the Smart Extension Service enable is only possible while online.)

- (1) Select [Online]→ [Communication module setting and Diagnosis]→ [Enable Services].

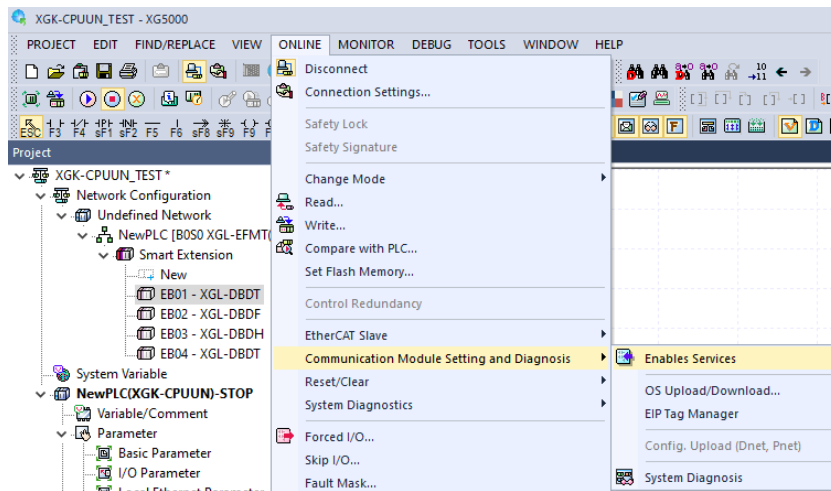

- (2) In the [Enable Service] window, check the Smart extension item and select OK to enable the Smart extension service. In addition, uncheck the Smart Extension item and select OK to disable the Smart Extension service.

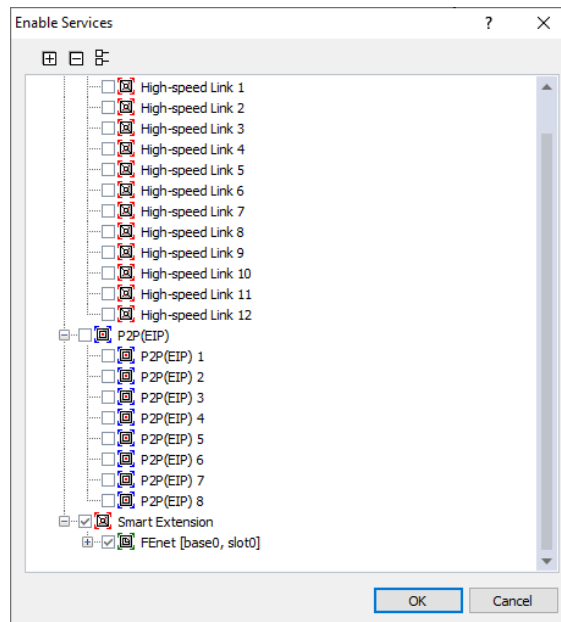

### 4.3 Hot Swapping function

Functions that mask errors in case of module failure and control the system with replaced modules include Fault Mask and IO skip. This feature is only supported by the Smart Extension Service and is not supported by other services. In a system equipped with a CPU, it is not set in the Smart Extension service but in the Error Operation Settings of the Basic Parameter Setting window of the CPU.

Ethernet(FENet) based Smart Extension system	Flags Updated When module detached
 <p>The diagram shows a system architecture with a CPU at the top, connected to three extension bases: EB01, EB02, and EB63. A red star is placed on Slot 6 of EB02, with a label 'Slot 6 Module detached' pointing to it. A yellow box highlights the CPU and EB01, and a dashed yellow line connects EB01 to EB02.</p>	<ul style="list-style-type: none"> <li>• <code>_0001_IO_DEER</code> : IO detachment error flag of Smart extension system with Ethernet installed in slot 1 of base 0</li> <li>• <code>_0001_EB02_IO_DEER</code> : IO detachment error flag by EB in Smart extension system</li> <li>• <code>_0001_EB02_S06_IO_DEER</code> : IO detachment error flag Slot 6 of Smart Extension system</li> </ul>

#### 4.3.1 Hot Swap Operation

Operation	Hot Swap Enable	Hot Swap Disable
Module change	Provided by	Unavailable
Module detach	Master hold previous mode	Master hold previous mode, Extension base where an error occurs is operated in error mode
	Perform control by referring to the flag that is updated by the user when module detached Perform control by referring to the flag that is updated by the user when adding and deleting EB	Output operation can be specified in case of digital output module error

4.3.2 Hot Swap Operation setting

The hot swap setting is set by the Smart Extension service.

- (1) Double-click [Project] → [Smart Extension] window.

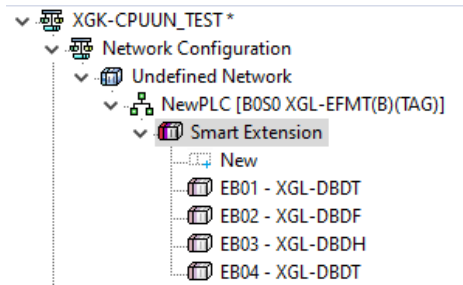

- (2) Click [Smart Extension] → [Communication Device Settings] to display the screen on the right.

Checking "Exchange EB or modules while running (hot swap)" in the setting item performs hot swap operation.

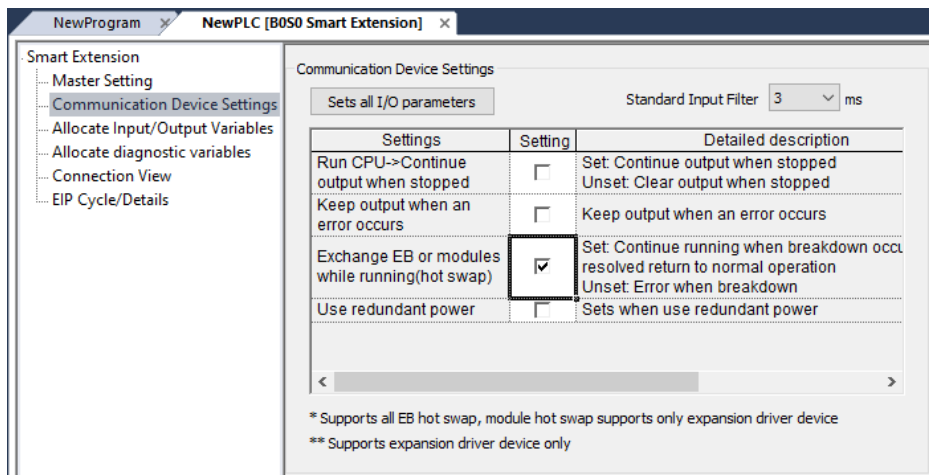

- (3) To set by Communication device, select EB of Communication device and cancel "Enables Master Communication Device" in Basic Parameter item and set as below.

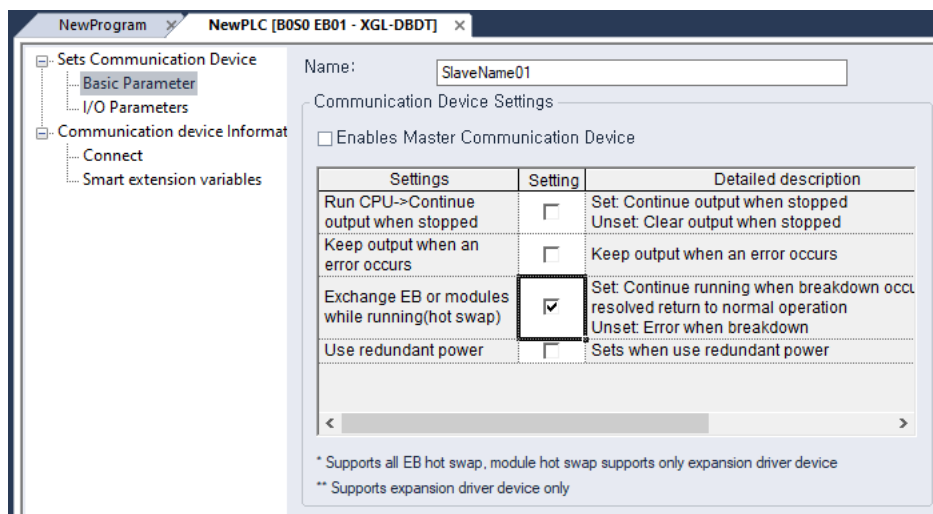

4.3.3 Diagnostic Variable Operation According to Exchange EB or modules while running (hot swap) Option

Some of the Allocate diagnostic variables depend on the setting of the Exchange EB or modules while running (hot swap) option. The operation of Diagnostic Variables according to the option setting is as follows.

(1) System diag operation

System diag name	Hot Swap Settings in EB	Diagnostic Variable Operation with Hot Swap setting
_BBSS_SYSTEM_ER	Hot swap settings are mixed(Enable/ Disable)	Hold "Off"
	Hot swap settings are all Enabled	Hold "Off"
	Hot swap settings are all Disabled	"ON" when EB detachment or EB I / O detachment occurs
_BBSS_SYSTEM_WAR	Hot swap settings are mixed(Enable/ Disable)	"On" if an EB detachment or EB I / O module detachment occurs in an EB with hot-swap setting disabled.
	Hot swap settings are all Enabled	Hold "Off"
	Hot swap settings are all Disabled	Hold "Off"
_BBSS_EB_DEER	Hot swap settings are mixed(Enable/ Disable)	"On" if an EB detachment occurs in an EB with hot-swap setting disabled.
	Hot swap settings are all Enabled	Hold "Off"
	Hot swap settings are all Disabled	"On" if an EB detachment occurs
_BBSS_IO_DEER	Hot swap settings are mixed(Enable/ Disable)	"On" if an I/O module detachment occurs in an EB with hot-swap setting disabled.
	Hot swap settings are all Enabled	Hold "Off"
	Hot swap settings are all Disabled	"On" if an I/O module detachment occurs
_BBSS_EB_DETACH_WAR	Hot swap settings are mixed(Enable/ Disable)	"ON" if an EB detachment occurs in an EB with hot-swap setting enabled.
	Hot swap settings are all Enabled	"ON" if an EB detachment occurs in an EB with hot-swap setting enabled.
	Hot swap settings are all Disabled	Hold "Off"
_BBSS_IO_DETACH_WAR	Hot swap settings are mixed(Enable/ Disable)	"On" if an I/O module detachment occurs in an EB with hot-swap setting enabled.
	Hot swap settings are all Enabled	"On" if an I/O module detachment occurs in an EB with hot-swap setting enabled.
	Hot swap settings are all Disabled	Hold "Off"
_BBSS_FUSE_WAR	Hot swap settings are mixed(Enable/ Disable)	"ON" if an FUSE error occurs in an EB with hot-swap setting enabled.
	Hot swap settings are all Enabled	"ON" if an FUSE error occurs in an EB with hot-swap setting enabled.
	Hot swap settings are all Disabled	Hold "Off"
_BBSS_EB_ER	Hot swap settings are mixed(Enable/ Disable)	"On" if an EB detachment or EB I / O module detachment occurs in an EB with hot-swap setting disabled.
	Hot swap settings are all Enabled	Hold "Off"
	Hot swap settings are all Disabled	"ON" when EB detachment or EB I / O detachment occurs

\* \_BBSS: Displays the BASE and SLOT positions with the master module

(2) EB diag operation

EB diag name	Hot Swap Settings in EB	Diagnostic Variable Operation with Hot Swap setting
_BBSS_EBXX_IO_DEER	Hot swap settings are Enable	Hold "Off"
	Hot swap settings are Disable	"On" if an I/O module detachment of EB occurs
_BBSS_EBXX_FUSE_ER	Hot swap settings are Enable	Hold "Off"
	Hot swap settings are Disable	"On" if FUSE error occurs in the I/O module of EB

\_BBSS: Displays the BASE and SLOT positions with the master module

## 4.3.4 Operation by Hot Swap Setting

The system below is an example of a mix of hot-swap Setting



(1) Module detached from base with hot swap enable

1) Operation

EB01 to EB04 base operates normally when slot 1 module of EB01 with hot swap enabled is detached. The detached module operates according to the emergency output setting.



2) System diag

All System diag are turned Off.

System diag	Monitoring value
SYSTEM_ER	OFF
SYATEM_WAR	OFF
EB_DEER	OFF
IO_DEER	OFF
EB_ER_00	OFF
EB_ER_01	OFF
EB_ER_02	OFF
EB_ER_03	OFF
EB_ER_04	OFF

3) EB Diagnostic variables

The diagnostic variable is turned On because the IO module of EB 01 is detached.

EB01(Hot swap:Enable)		EB02(Hot swap:Enable)		EB03(Hot swap: Disable)		EB04(Hot swap: Disable)	
Diagnostic variables	Monitoring value	Diagnostic variables	Monitoring value	Diagnostic variables	Monitoring value	Diagnostic variables	Monitoring value
EB01_DEER	OFF	EB02_DEER	OFF	EB03_DEER	OFF	EB04_DEER	OFF
EB01_IO_DEER	OFF	EB02_IO_DEER	OFF	EB03_IO_DEER	OFF	EB04_IO_DEER	OFF
EB01_S01_IO_DEER	ON	EB02_Sxx_IO_DEER	OFF	EB03_Sxx_IO_DEER	OFF	EB04_Sxx_IO_DEER	OFF

(2) Module detached from base with hot swap enable

1) Operation

EB03 / EB04 error and EB01 / EB02 operate normally when slot 1 module of EB03 with hot swap disabled is detached. Each module mounted on EB03 / EB04 shall be output according to the setting of “Keep output when an error occurs”.



2) System diag

System warning, IO detachment and EB\_ER\_03 / 04 are On.

System diag	Monitoring value
SYSTEM_ER	OFF
SYATEM_WAR	ON
EB_DEER	OFF
IO_DEER	ON
EB_ER_00	OFF
EB_ER_01	OFF
EB_ER_02	OFF
EB_ER_03	ON
EB_ER_04	ON

**Notes**

(1) If EB01 ~ EB04 is set to disable, SYSTEM\_ER, IO\_DEER and EB\_ER01 ~ EB04 are On when the module is detached from EB03, and Smart extension operation stops.

3) EB Diagnostic variables

The diagnostic variable is turned On because the IO module of EB 03 is detached.

EB01(Hot swap:Enable)		EB02(Hot swap:Enable)		EB03(Hot swap: Disable)		EB04(Hot swap: Disable)	
Diagnostic variables	Monitoring value	Diagnostic variables	Monitoring value	Diagnostic variables	Monitoring value	Diagnostic variables	Monitoring value
EB01_DEER	OFF	EB02_DEER	OFF	EB03_DEER	OFF	EB04_DEER	OFF
EB01_IO_DEER	OFF	EB02_IO_DEER	OFF	EB03_IO_DEER	OFF	EB04_IO_DEER	OFF
EB01_Sxx_IO_DEER	OFF	EB02_Sxx_IO_DEER	OFF	EB03_S01_IO_DEER	ON	EB04_Sxx_IO_DEER	OFF

(3) EB detached with hot swap enable

1) Operation

EB02 to EB04 operates normally when EB01 with hot swap enabled is detached. When detachment of EB01 is released, it operates normally.

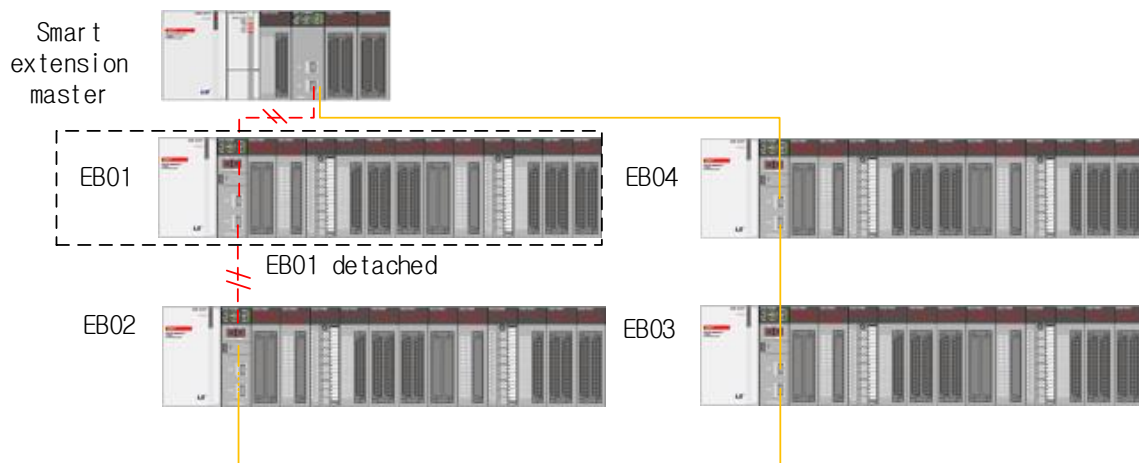

2) System diag

All System diag are turned Off.

System diag	Monitoring value
SYSTEM_ER	OFF
SYATEM_WAR	OFF
EB_DEER	OFF
IO_DEER	OFF
EB_ER_00	OFF

EB_ER_01	OFF
EB_ER_02	OFF
EB_ER_03	OFF
EB_ER_04	OFF

3) EB Diagnostic variables

If EB 01 is dropped, EB01\_DEER variable is ON.

EB01(Hot swap:Enable)		EB02(Hot swap:Enable)		EB03(Hot swap: Disable)		EB04(Hot swap: Disable)	
Diagnostic variables	Monitoring value	Diagnostic variables	Monitoring value	Diagnostic variables	Monitoring value	Diagnostic variables	Monitoring value
EB01_DEER	ON	EB02_DEER	OFF	EB03_DEER	OFF	EB04_DEER	OFF
EB01_IO_DEER	OFF	EB02_IO_DEER	OFF	EB03_IO_DEER	OFF	EB04_IO_DEER	OFF
EB01_S01_IO_DEER	OFF	EB02_Sxx_IO_DEER	OFF	EB03_Sxx_IO_DEER	OFF	EB04_Sxx_IO_DEER	OFF

(4) EB detached with hot swap disabled

1) Operation

EB03 / EB04 error and EB01 / EB02 operate normally when EB03 with hot swap disabled is detached. Each module mounted on EB03 / EB04 shall be output according to the setting of “Keep output when an error occurs”.

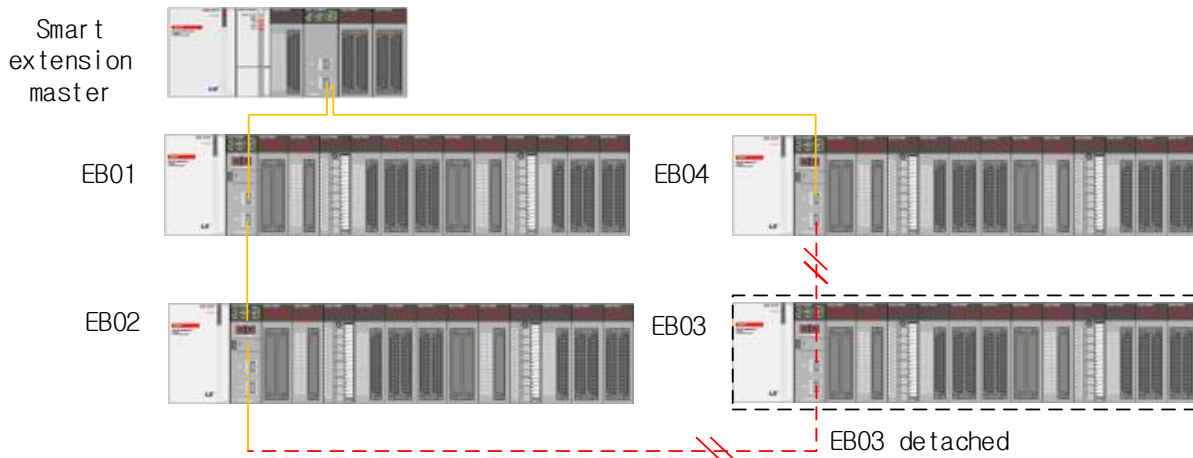

2) System diag

System warning, EB detachment and EB\_ER\_03 / 04 are ON.

System diag	Monitoring value
SYSTEM_ER	OFF
SYATEM_WAR	ON
EB_DEER	ON
IO_DEER	OFF
EB_ER_00	OFF
EB_ER_01	OFF
EB_ER_02	OFF

EB_ER_03	ON
EB_ER_04	ON

**Notes**

If EB01 ~ EB04 is set to disable, SYSTEM\_ER, EB\_DEER and EB\_ER01 ~ EB04 are ON when EB03 is detached and Smart extension operation stops.

3) EB Diagnostic variables

IO module detachment diagnostic variables of EB 03 turns ON.

EB01(Hot swap:Enable)		EB02(Hot swap:Enable)		EB03(Hot swap: Disable)		EB04(Hot swap: Disable)	
Diagnostic variables	Monitoring value	Diagnostic variables	Monitoring value	Diagnostic variables	Monitoring value	Diagnostic variables	Monitoring value
EB01_DEER	OFF	EB02_DEER	OFF	EB03_DEER	OFF	EB04_DEER	OFF
EB01_IO_DEER	OFF	EB02_IO_DEER	OFF	EB03_IO_DEER	OFF	EB04_IO_DEER	OFF
EB01_Sxx_IO_DEER	OFF	EB02_Sxx_IO_DEER	OFF	EB03_S01_IO_DEER	ON	EB04_Sxx_IO_DEER	OFF

4.3.5 Operation and Return Condition of Communication Device According to Hot Swap Setting

(1) Hot Swap with EB01 to EB06 Systems

EB No.	Device	Hot swap setting
EB 01	Extension driver	Disable
EB 02	Extension driver	Enable
EB 03	Smart I/O expansion	Disable
EB 04	Smart I/O expansion	Enable
EB 05	Smart I/O block	Disable
EB 06	Smart I/O block	Enable

(2) Communication Device Operation

Normal operation: ○ , Emergency output: ⊙ ,Emergency output besides fault module: □

Condition	Error condition	Error operation						Full service return condition
		EB01	EB02	EB03	EB04	EB05	EB06	
1	Module failure mounted on EB01	□	○	⊙	○	⊙	○	1. Fault module measure 2. Master reset or service Disable -> Enable
2	EB01 detachment	⊙	○	⊙	○	⊙	○	1. Reconnect EB 2. Master reset or service Disable -> Enable
3	Module failure mounted on EB02	○	□	○	○	○	○	1. Automatic return on fault module measure
4	EB02 detachment	○	⊙	○	○	○	○	1.Auto return on EB reconnect
5	Module failure mounted on EB03	⊙	○	□ <sup>Note 1</sup>	○	⊙	○	1. Fault module measure 2. EB Reset 3. Master reset or service Disable -> Enable
6	EB03 detachment	⊙	○	⊙	○	⊙	○	1. Reconnect EB 2. Master reset or service Disable -> Enable
7	Module failure mounted on EB04	○	○	○	⊙	○	○	1. Fault module measure 2. Auto return when relevnat EB reset
8	EB04 detachment	○	○	○	⊙	○	○	1. Auto return on EB reconnect
9	EB05 detachment	⊙	○	⊙	○	⊙	○	1. Reconnect EB 2. Master reset or service Disable -> Enable
10	EB06 detachment	○	○	○	○	○	⊙	1. Auto return on EB reconnect

Master Reset or Service Disable-> enable is required for the system to operate normally when an EB that is not hot swapped fails.

### Notes

- (1) When hot swap of each country operated by Smart extension service is set to Enable and the media is set to Auto, each station automatically operates by adjusting the communication speed. If there is only 100M of station number, the system communicates with 100M.
- (2) When hot swap of each country operated by Smart extension service is set to Disable and the media is set to Auto, each station automatically operates by adjusting the communication speed. However, if 100M and 1G media are mixed, EB will be detached when connecting to media with different speeds. In this case, Smart extension service can be operated after setting communication media setting of each station from Auto to 100M.
- (3) Smart I / O expansion does not support hot swap function of expansion module.

4.4 Smart Extension service operation

(1) Program using Smart Extension Wizard

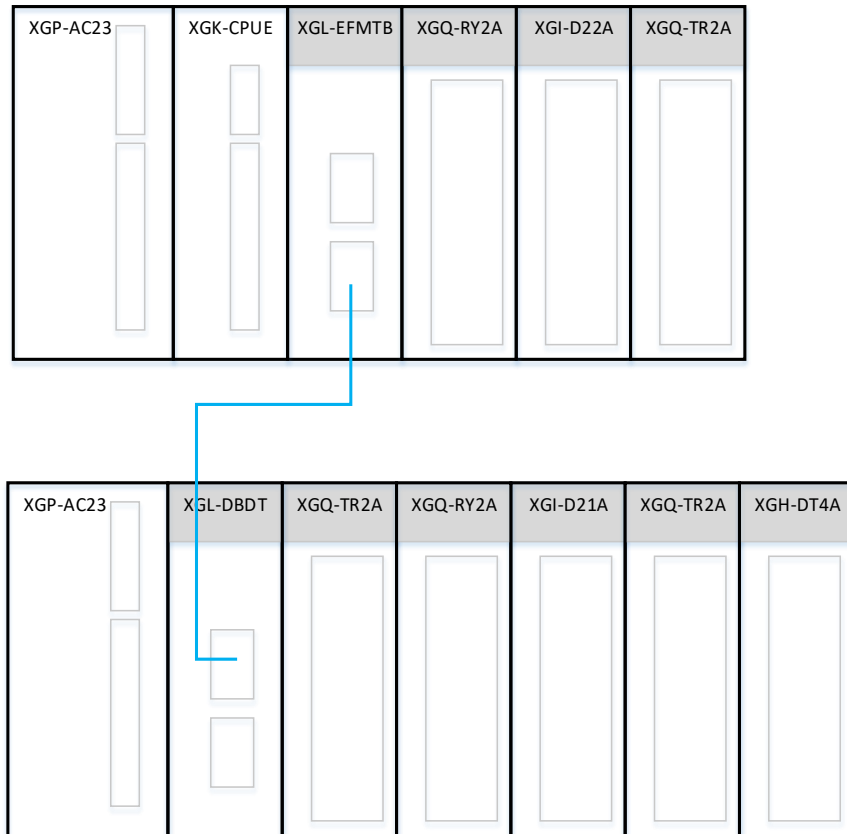

► Program to turn on the output contact point connected to the expansion stage 1 using the Smart expansion service

Program procedures

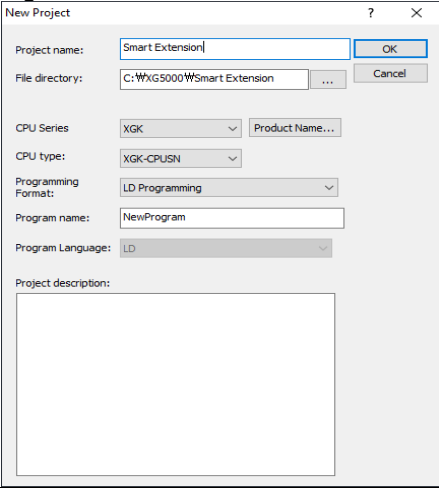
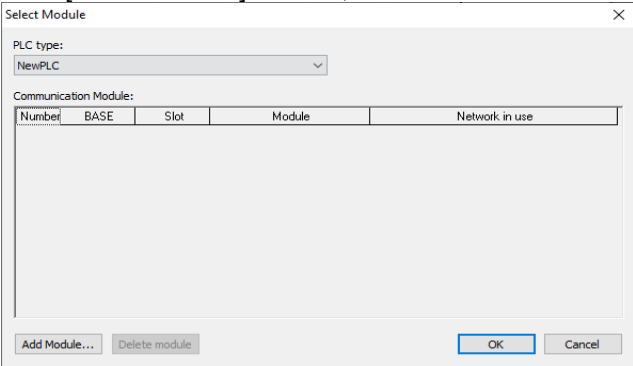
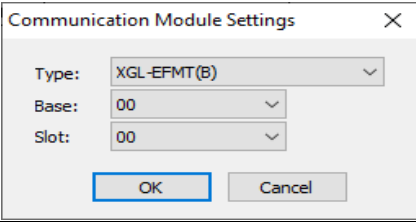
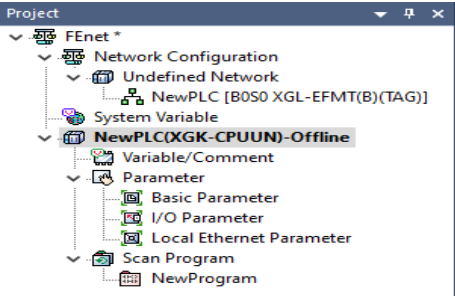
Sequence	Setting process	Setting method
1	Create new project	<p>1) [Project]→Open [New Project] and enter the project name, CPU series, CPU type, programming type, and program name.</p> 
2	Undefined Network Add	<p>1) Select [Undefined Network]→[Add item]→ [Communication module].                  2) In the [Select Module] window, click "Add module".</p>  <p>1) Setting the Type, Base and Slot. After that, select the "OK" button to complete the setting.</p> 
3	Standard settings	<p>Double-click the communication module in the [Project] window.</p> 

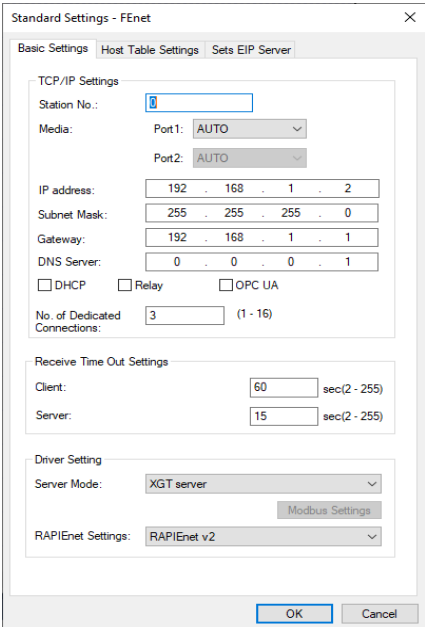
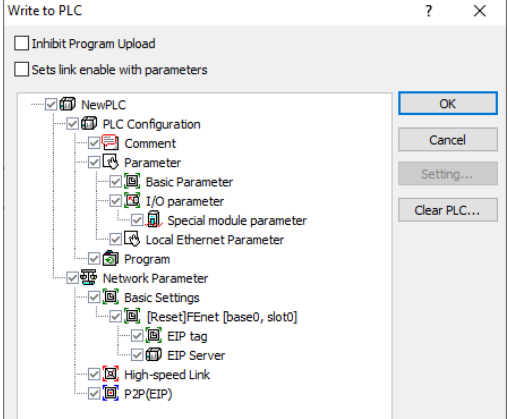
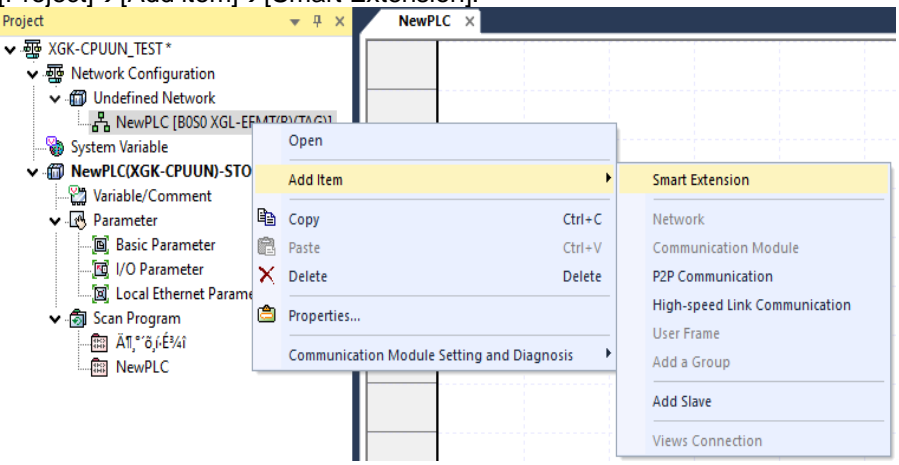
Sequence	Setting process	Setting method
3	Standard settings	<p>Enter TCP / IP Settings, Receive time out Settings, and Driver settings on the [Basic Settings] tab.</p>  <p>Click [Online]→[Write] and select and download the master module of the network parameter. Downloaded parameters are applied after reset.</p> 
4	Adding Smart Extension service	<p>Click [Project]→[Add item]→[Smart Extension].</p> 

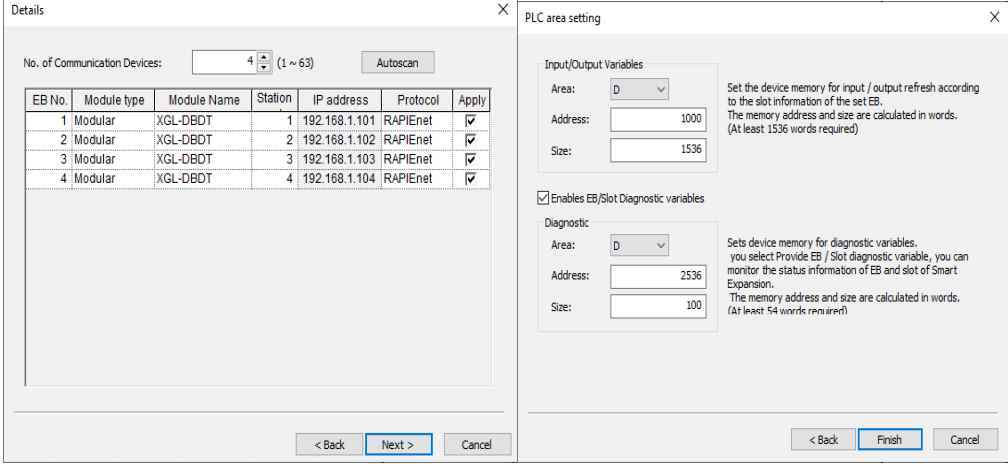
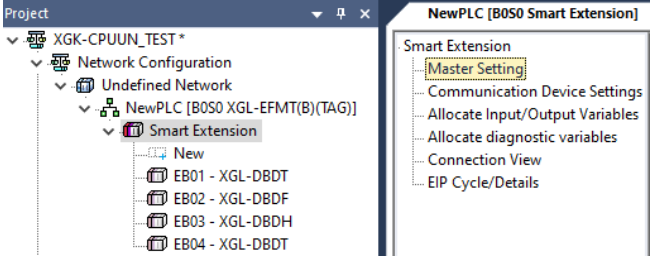
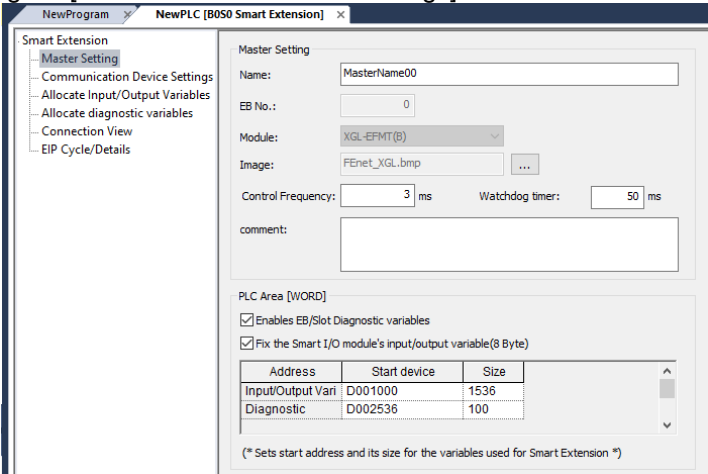
Sequence	Setting process	Setting method
4	Adding Smart Extension service	<p>1) Select “Autoscan” on the [Overview]→[Details] window to automatically register the connected network. (PLC system should be connected in [Online]→[Connect] before Autoscan.)</p> <p>2) Set input / output variables and diagnostic variables as initial values in the [PLC Area Setting] window. Then proceed to Section 7.</p>  <p>3) If select “Cancel” on the [Overview]→[Details] window ,start from section 5 below.</p>
5	Master Setting	<p>1) Double-click [Smart Extension] and click the [Master Setting] menu.</p>  <p>2) Input Master Setting and PLC area in [Master Setting] and Communication Device Settings in [Communication Device Settings].</p>  <p>(* Sets start address and its size for the variables used for Smart Extension *)</p>

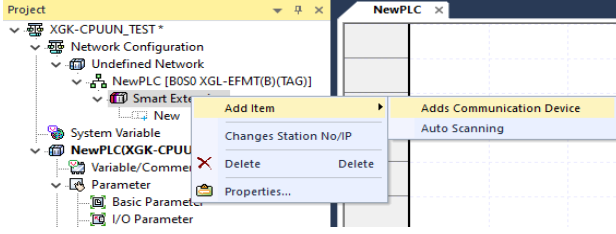
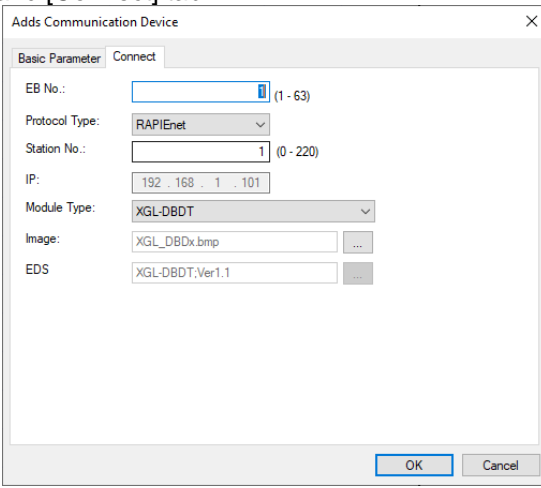
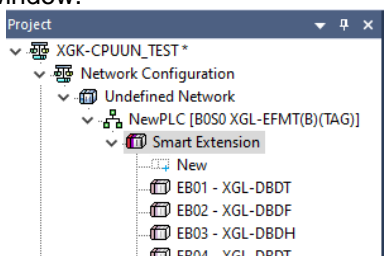
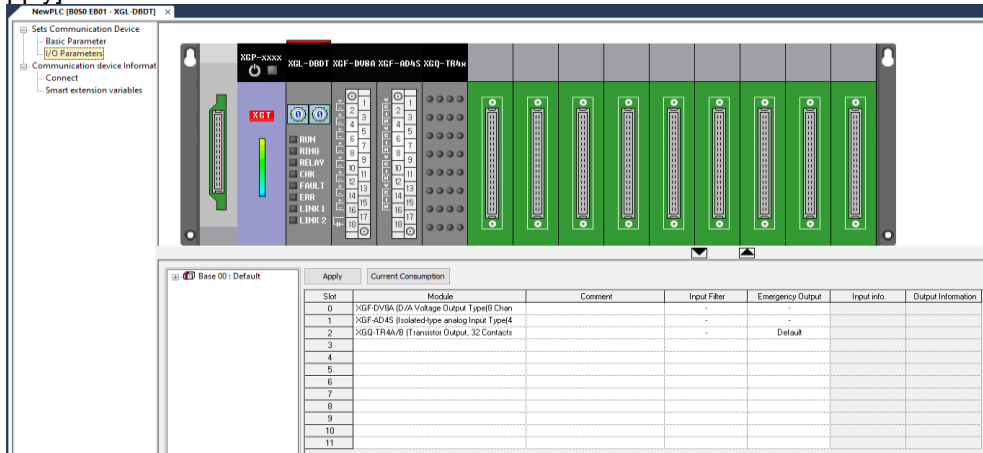
Sequence	Setting process	Setting method																																																																																									
6	Communication device setting	<p>1) Click [Smart Extension]→[Add Item]→ [Add Communication Device].</p> 																																																																																									
		<p>2) In the [Adds Communication Device] window, enter the contents of the [Basic Parameter] and [Connect] tab.</p> 																																																																																									
		<p>3) Double-click [Smart Extension]→[EB01-XGL-DBDT] and click the [I / O Parameter] menu in the [B0S0 EB01] window.</p> 																																																																																									
		<p>4) Register I / O module installed in communication device in [I / O Parameter] and click [Apply] button.</p>  <table border="1" data-bbox="784 1917 1462 2091"> <thead> <tr> <th>Slot</th> <th>Module</th> <th>Comment</th> <th>Input Filter</th> <th>Emergency Output</th> <th>Input info</th> <th>Output Information</th> </tr> </thead> <tbody> <tr> <td>0</td> <td>XGF-DV9A (D/A Voltage Output Type)B Chan</td> <td></td> <td>-</td> <td>-</td> <td></td> <td></td> </tr> <tr> <td>1</td> <td>XGF-A04S (Isolated-type analog Input Type)4</td> <td></td> <td>-</td> <td>-</td> <td></td> <td></td> </tr> <tr> <td>2</td> <td>XGG-TR6A/B (Transistor Output, 32 Contacts</td> <td></td> <td>-</td> <td>Default</td> <td></td> <td></td> </tr> <tr> <td>3</td> <td></td> <td></td> <td></td> <td></td> <td></td> <td></td> </tr> <tr> <td>4</td> <td></td> <td></td> <td></td> <td></td> <td></td> <td></td> </tr> <tr> <td>5</td> <td></td> <td></td> <td></td> <td></td> <td></td> <td></td> </tr> <tr> <td>6</td> <td></td> <td></td> <td></td> <td></td> <td></td> <td></td> </tr> <tr> <td>7</td> <td></td> <td></td> <td></td> <td></td> <td></td> <td></td> </tr> <tr> <td>8</td> <td></td> <td></td> <td></td> <td></td> <td></td> <td></td> </tr> <tr> <td>9</td> <td></td> <td></td> <td></td> <td></td> <td></td> <td></td> </tr> <tr> <td>10</td> <td></td> <td></td> <td></td> <td></td> <td></td> <td></td> </tr> <tr> <td>11</td> <td></td> <td></td> <td></td> <td></td> <td></td> <td></td> </tr> </tbody> </table>	Slot	Module	Comment	Input Filter	Emergency Output	Input info	Output Information	0	XGF-DV9A (D/A Voltage Output Type)B Chan		-	-			1	XGF-A04S (Isolated-type analog Input Type)4		-	-			2	XGG-TR6A/B (Transistor Output, 32 Contacts		-	Default			3							4							5							6							7							8							9							10							11				
Slot	Module	Comment	Input Filter	Emergency Output	Input info	Output Information																																																																																					
0	XGF-DV9A (D/A Voltage Output Type)B Chan		-	-																																																																																							
1	XGF-A04S (Isolated-type analog Input Type)4		-	-																																																																																							
2	XGG-TR6A/B (Transistor Output, 32 Contacts		-	Default																																																																																							
3																																																																																											
4																																																																																											
5																																																																																											
6																																																																																											
7																																																																																											
8																																																																																											
9																																																																																											
10																																																																																											
11																																																																																											

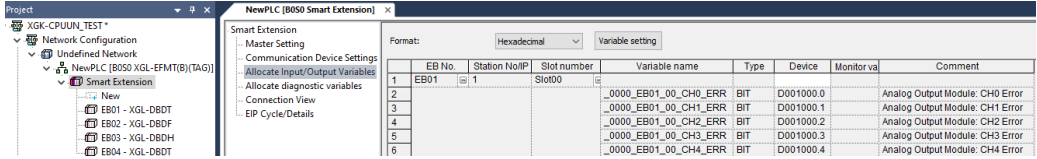
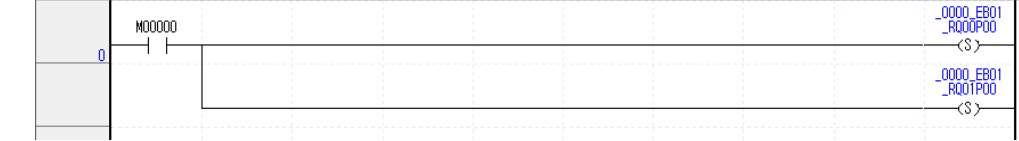
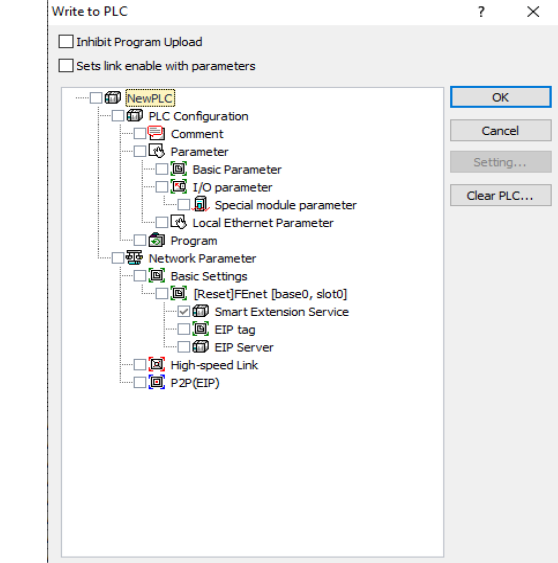
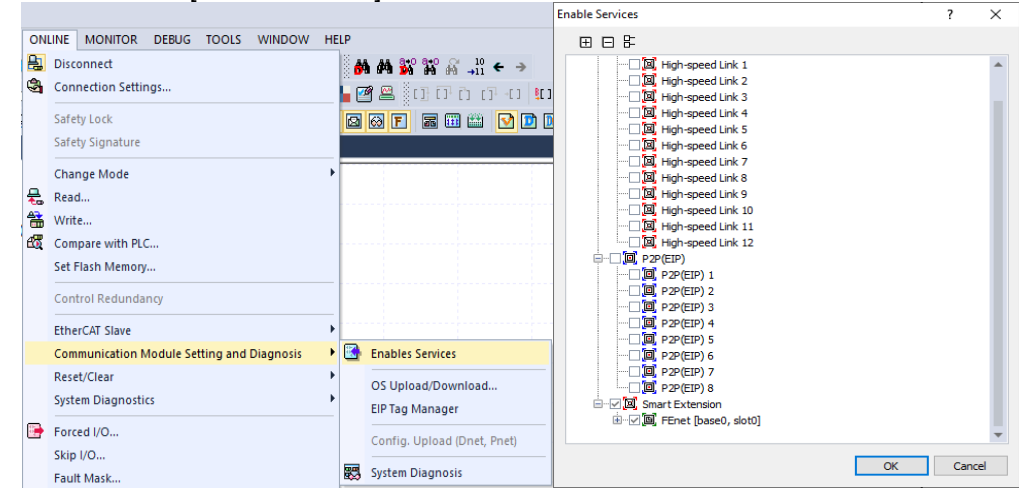
Sequence	Setting process	Setting method
7	Allocate input/output variables	<p>1) [Smart extension]→Open [Input / Output Variable Assignment] and click "Register Variable". It can be created by referring to the program after registering the variable</p> 
8	programming	<p>1) Create NewProgeam of the scan program. At this time, output contact no.0 of slot 0 and slot 1 of Extension driver are displayed as " _0000_EB01_RQ00P00" and " _0000_EB01_RQ01P00" respectively.</p> 
9	Program Download	<p>In the [Online]→[Write] window ,Click ok.</p> 
10	Set link enable	<p>[Online]→[Communication module setting and diagnosis]→Check Smart extension in [Service Enable].</p> 

## 4.5 Smart extension diagnosis function

Smart extension service is provided with diagnostic function. Check the service status of Smart extension service by using service status, communication module history, diagnostic variables, Communication device connection configuration, EIP cycle / detailed setting list.

### 4.5.1 Status by service (Smart extension)

(1) Select [Online]→ [Communication module setting and Diagnosis] → [System diagnosis].

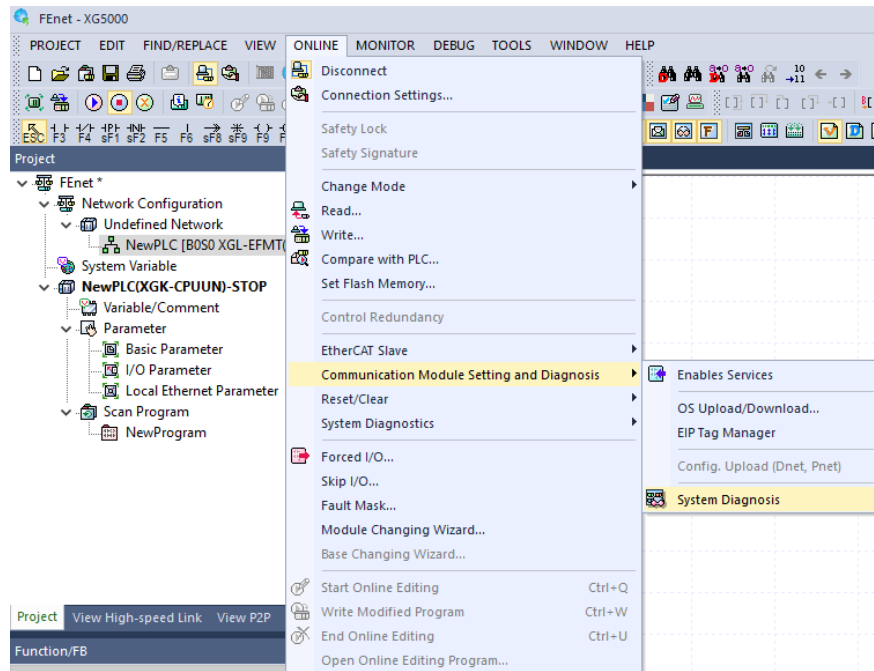

(2) In the [System Diagnosis] window, right-click the "Ethernet module image area" and select the service-specific status.

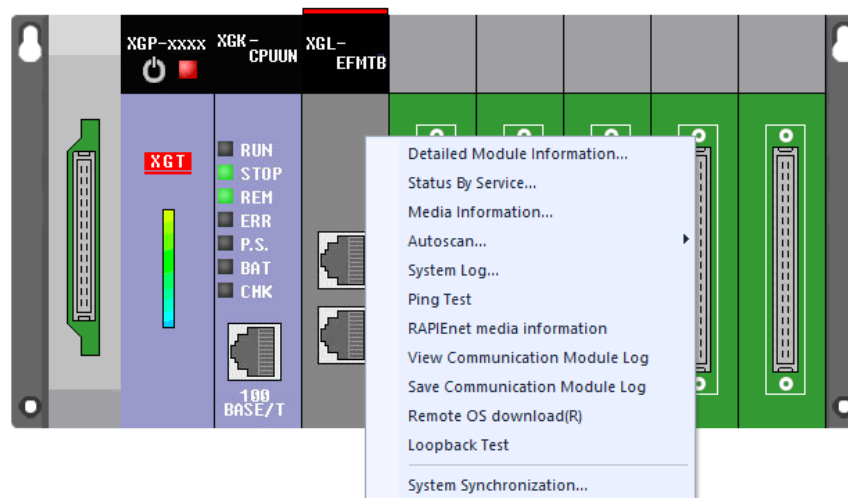

(3) Check the service status of the Smart extension by selecting the [Status by Service]→[Smart Extension] tab.

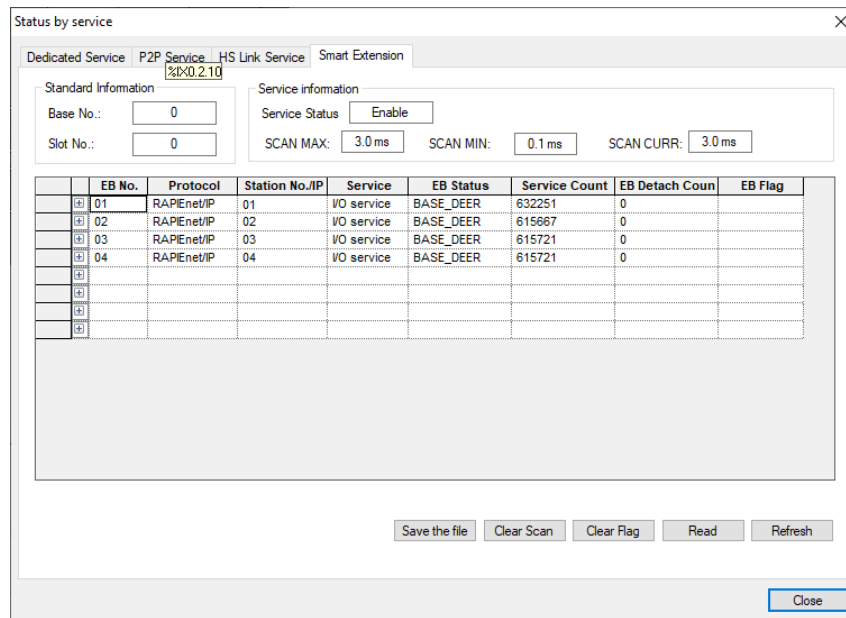

Item	Contents																
Base Number	Displays the base number on which the Ethernet module is mounted.																
Slot No.	Displays the slot number on which the Ethernet module is mounted.																
Service status	Displays the enabled status of the Smart extension service. - Types of service status and descriptions are as follows. <table border="1" style="width: 100%;"> <thead> <tr> <th>Service status type</th> <th>Description</th> </tr> </thead> <tbody> <tr> <td>Enable</td> <td>Operating Smart Extension service.</td> </tr> <tr> <td>Disable</td> <td>Stop Smart Extension service.</td> </tr> </tbody> </table>	Service status type	Description	Enable	Operating Smart Extension service.	Disable	Stop Smart Extension service.										
Service status type	Description																
Enable	Operating Smart Extension service.																
Disable	Stop Smart Extension service.																
SCAN MAX	Smart extension service displays the maximum scan cycle of the network.																
SCAN MIN	Smart extension service displays the minimum scan cycle of the network.																
SCAN CURR	Smart extension service displays the current scan cycle of the network.																
EB No.	Displays the EB number of the communication device.																
Protocol	Displays the protocol type used for connection with the communication device.																
Station No/IP	Displays the station number / IP of the communication device. - Displays the station number when the protocol type is RAPIenet. - Displays the IP address when the protocol type is EtherNet / IP.																
Service	Displays currently active services. - I/O service: Service provided by communication device with Smart Extension function - Event service: EtherNet / IP Client Service																
EB status	Displays the current EB status. <table border="1" style="width: 100%;"> <thead> <tr> <th>Service status</th> <th>Description</th> </tr> </thead> <tbody> <tr> <td>IDLE</td> <td>The communication device (slave) to be controlled is not connected in the network.</td> </tr> <tr> <td>DETECTING</td> <td>Looking for communication device (slave).</td> </tr> <tr> <td>STATE_CFM</td> <td>The communication device has been checked.</td> </tr> <tr> <td>PRM_DONE</td> <td>Parameter download has been completed to the communication device.</td> </tr> <tr> <td>IO_PRM_MISS_MATC H</td> <td>The parameter I / O list and the I / O list mounted on the communication device are different.</td> </tr> <tr> <td>WORKING</td> <td>It is the status to update I / O data normally.</td> </tr> <tr> <td>DETACH</td> <td>The Communication device is detached during the control.</td> </tr> </tbody> </table>	Service status	Description	IDLE	The communication device (slave) to be controlled is not connected in the network.	DETECTING	Looking for communication device (slave).	STATE_CFM	The communication device has been checked.	PRM_DONE	Parameter download has been completed to the communication device.	IO_PRM_MISS_MATC H	The parameter I / O list and the I / O list mounted on the communication device are different.	WORKING	It is the status to update I / O data normally.	DETACH	The Communication device is detached during the control.
Service status	Description																
IDLE	The communication device (slave) to be controlled is not connected in the network.																
DETECTING	Looking for communication device (slave).																
STATE_CFM	The communication device has been checked.																
PRM_DONE	Parameter download has been completed to the communication device.																
IO_PRM_MISS_MATC H	The parameter I / O list and the I / O list mounted on the communication device are different.																
WORKING	It is the status to update I / O data normally.																
DETACH	The Communication device is detached during the control.																

Service count	Displays the service operation counts currently.
Error count	Displays the count of errors that have occurred currently.
EB detachment count	Displays the EB detachment counts that have occurred currently.
EB flag	Flag is displayed according to the type of error occurred when an error occurs in EB.
Slot No. (slot)	Displays the slot number (EB).
Type(slot)	Displays the module type installed in the slot (EB). - For EtherNet / IP( EIP ) clients, displays the service type.
Status(slot)	Displays the service status of the slot (EB).
Block Status(slot)	Display the status of that service block. - This feature is only available for EIP clients.
Error code (Slot)	The error code of the service is displayed. - This feature is only available for EIP clients.
Service count(slot)	The service count of the service is displayed. - This feature is only available for EIP clients.
Error count(Slot)	The error count of the service is displayed. - This feature is only available for EIP clients.
Slot flag (slot)	Flag is displayed according to the type of error occurred when an error occurs in slot.
File save	Saves the current status of Smart extension service as a file.
Clear scan	Initializes the scan information. Initializes the SCAN MAX and SCAN MIN values.
Clear flag	Initialize the EB flag and slot flag (slot). - Error flag history is initialized.
Continuous reading	Smart extension service status is updated continuously.

#### 4.5.2 View Communication Module Log

Check the event history and communication history of the Ethernet module by using the communication module history view function of system diagnosis. In the event history, event history such as joining and dropping of communication device nodes and mode switching history of communication module can be checked. In communication history, communication error history such as response waiting time exceeded, CRC error history, etc. can be checked.

- (1) Select [Online]→ [Communication module setting and Diagnosis] → [System diagnosis].

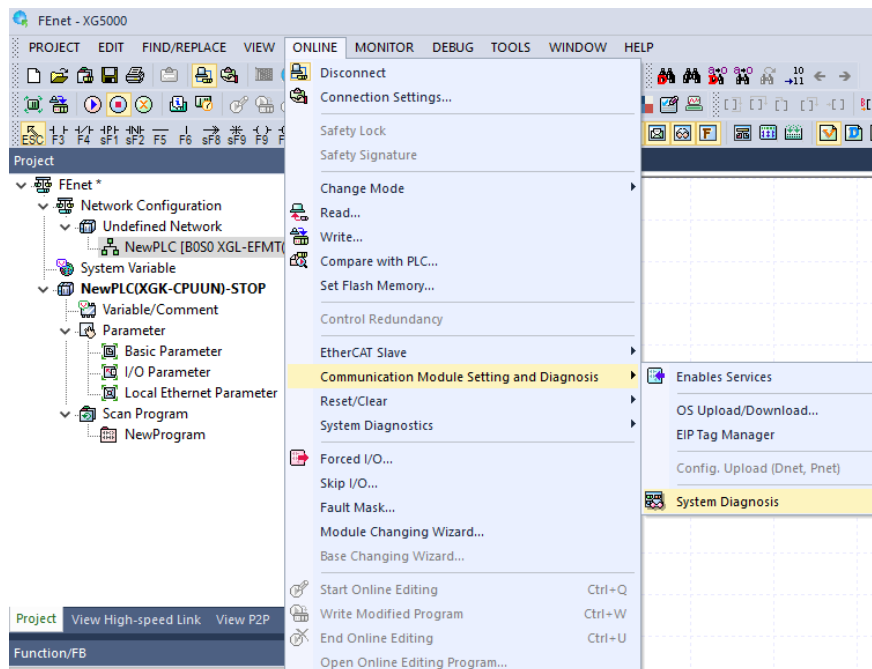

- (2) In the [System Diagnosis] window, right-click the "Ethernet module image area" and select the [View Communication Module Log]

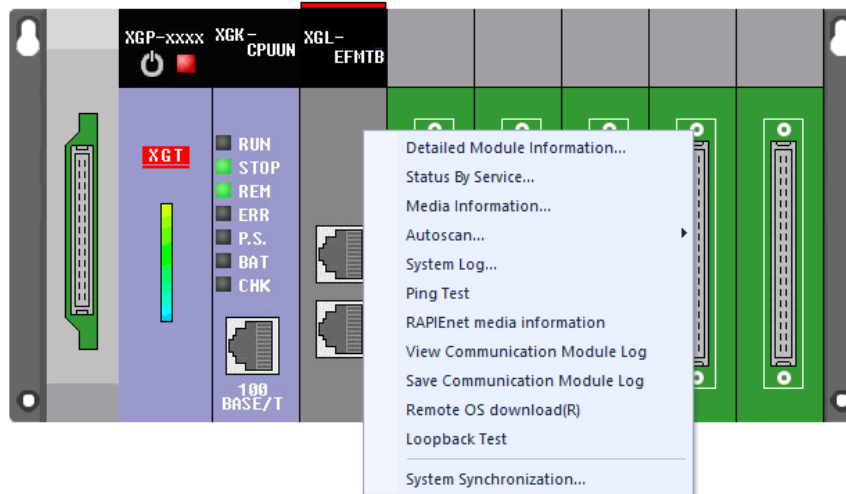

- (3) Check the event history by selecting [Event History] in the [View Communication Module Log] window.  
(Click the error history to display the details of the error and the corrective action.)

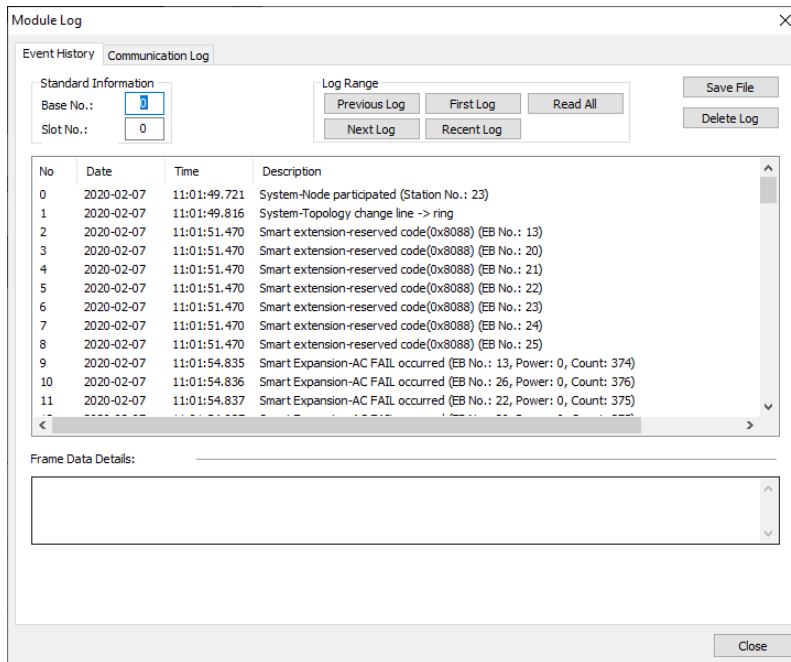

- (4) Check the communication error history by selecting [Communication history] at the top of [Module log] window.  
(Click the error history to display the details of the error and the corrective action.)

Module Log

Event History Communication Log

Standard Information  
 Base No.: 0  
 Slot No.: 0

Log Range  
 Previous Log First Log Read All  
 Next Log Recent Log

Save File  
 Delete Log

No	Date	Time	Description
0	2020-02-07	09:35:10.241	Smart Expansion-Receive RAPIEnet auto scan results (Module ID: 0x00007001, Number of mo
1	2020-02-07	09:35:10.241	Smart Expansion-Receive RAPIEnet auto scan results (Module ID: 0x00007003, Number of mo
2	2020-02-07	09:35:10.241	Smart Expansion-Receive RAPIEnet auto scan results (Module ID: 0x00007003, Number of mo
3	2020-02-07	09:35:10.241	Smart Expansion-Receive RAPIEnet auto scan results (Module ID: 0x00007001, Number of mo
4	2020-02-07	09:35:10.241	Smart Expansion-Receive RAPIEnet auto scan results (Module ID: 0x00007001, Number of mo
5	2020-02-07	09:35:10.241	Smart Expansion-Receive RAPIEnet auto scan results (Module ID: 0x00007001, Number of mo
6	2020-02-07	09:35:10.241	Smart Expansion-Receive RAPIEnet auto scan results (Module ID: 0x00007001, Number of mo
7	2020-02-07	09:35:10.241	Smart Expansion-Receive RAPIEnet auto scan results (Module ID: 0x00007001, Number of mo
8	2020-02-07	09:35:11.538	Smart Expansion - Response Wait Timeout (OBJECT ID: 20, EB No.: 22, LINK ID: 0x141601C0)
9	2020-02-07	09:35:11.604	Smart Expansion - Response Wait Timeout (OBJECT ID: 20, EB No.: 26, LINK ID: 0x141A013A)
10	2020-02-07	09:35:25.242	Smart Expansion - Response Wait Timeout (OBJECT ID: 20, EB No.: 24, LINK ID: 0x1418016F)
11	2020-02-07	09:35:25.308	Smart Expansion - Response Wait Timeout (OBJECT ID: 20, EB No.: 26, LINK ID: 0x141A015C)

Frame Data Details:

Close

4.6 Smart extension system configuration

Smart extension service can be used in various system configurations. However, if 1Gbps and 100Mbps media are mixed in the system, it will operate at 100Mbps. In case of optical media, the transceiver should be mounted accordingly.

4.6.1 Typical Configuration

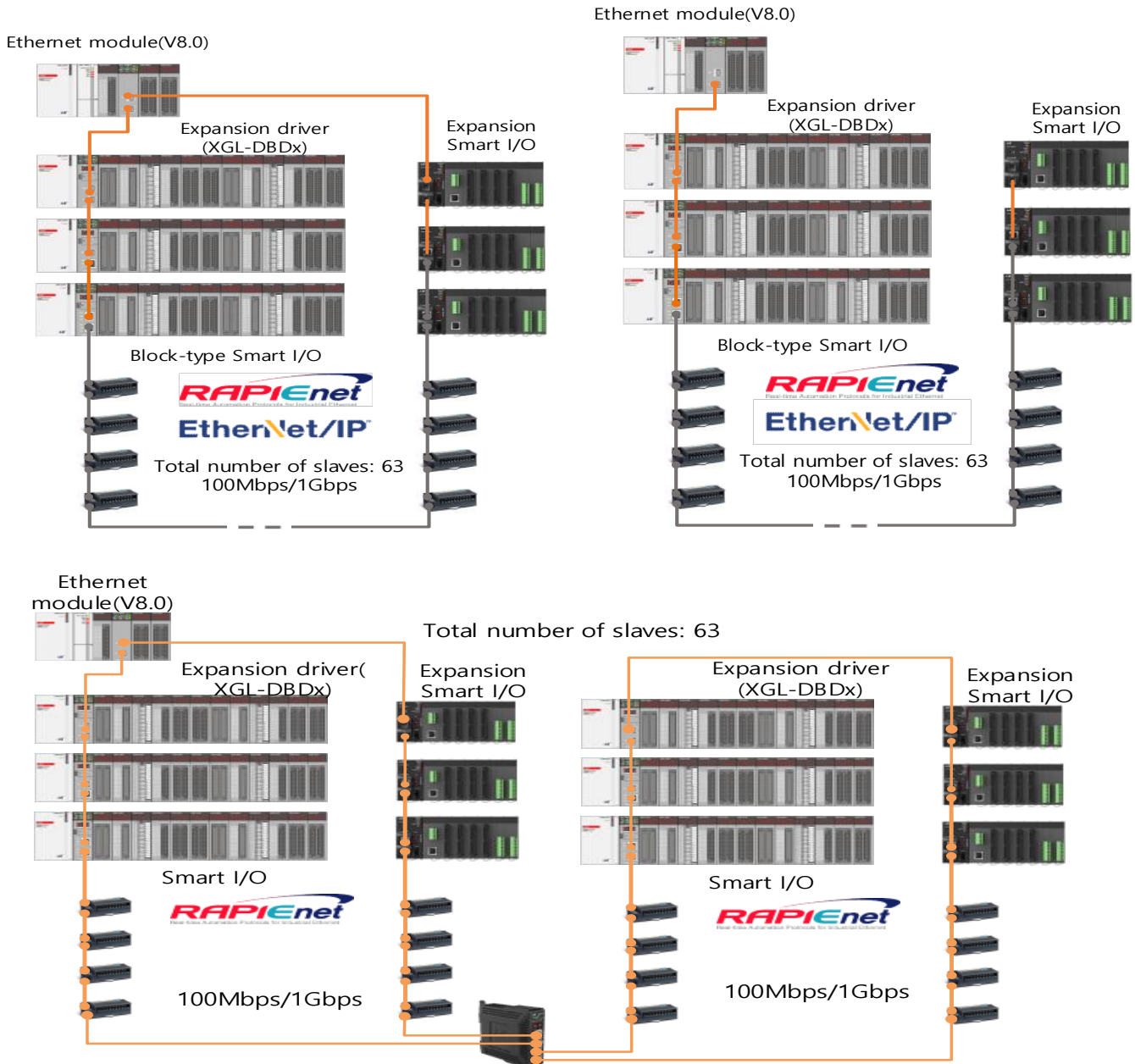

4.6.2 Ring / Line configuration.

Mix RAPIEnet and Ethernet / IP communication for ring / line configuration.

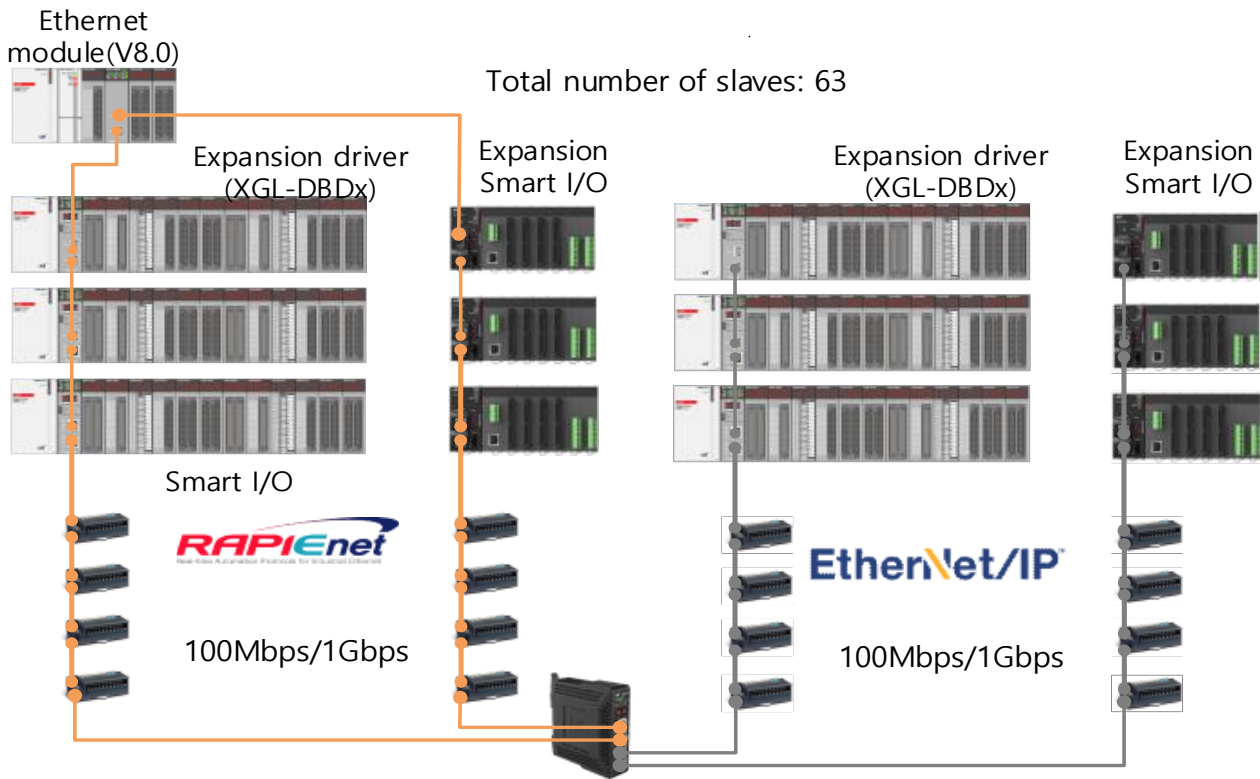

The switch module (MRS) does not support ring type connection when EtherNet / IP protocol is used.

Notes

- When using the EtherNet / IP protocol in the Smart extension service, general-purpose Ethernet switch can be used.
- When using the RAPIEnet protocol, communication is not guaranteed when using the general-purpose switch.
- When used as a Smart extension service with EtherNet / IP or RAPIEnet protocol, it operates at 100Mbps when 1Gbps and 100Mbps are simultaneously connected in the same ring.

4.6.3 Auto Speed Sync Operation

The Smart extension Master and Communication device modules provide an Auto Speed Sync function that automatically matches the speed of the two communication ports when the media setting of both communication ports is AUTO. At this time, the communication speed is synchronized to the lower of the communication speeds of the two ports. When all the conditions below are met, Auto Speed Sync function is activated and the media setting information is completed until the module is reset.

- (1) The media setting on the electrical port is AUTO - Electrical / Mixed Module
- (2) When the RAPIEnet setting is RAPIEnet v2 or when the RAPIEnet setting is Disable but the Relay option is Enable
- (3) When receiving service data (data for refreshing slave I / O module data (refresh data)) not setting data such as parameter data from other company or its master.

ex 1)When the link speed of the network is set to 100Mbps by the Auto Speed Sync function, if a node supporting all 1G / 100M is added to the network, the node is connected at 100M speed and the relay function of the neighboring node is also operated. Communication is possible

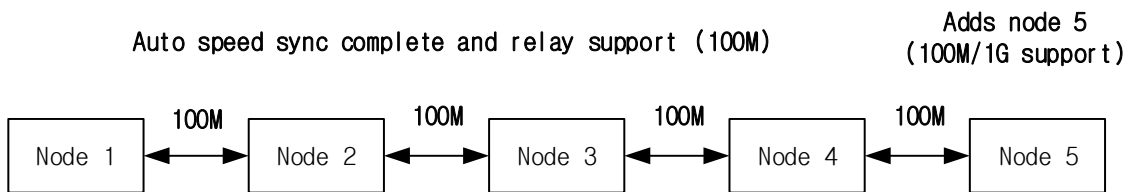

ex 2)When the link speed of the network is set to 100 Mbps by the Auto Speed Sync function, if a node that supports only 1G is added to the network, communication is not possible because the communication link between neighboring nodes is not established.

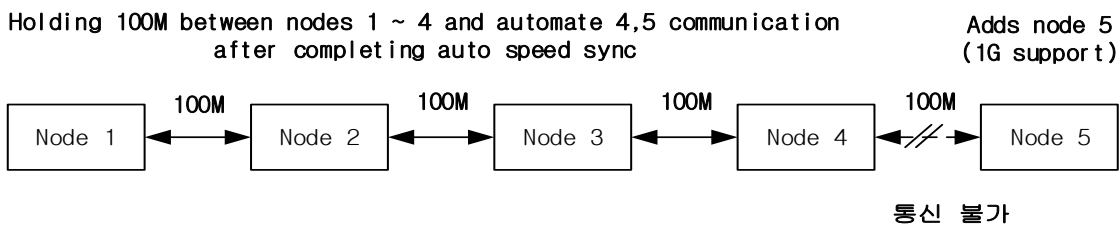

ex 3) If a network that supports only 100M is added to the network when the link speed of the network is set to 1 Gbps by the auto speed sync function, the link communicates at 100M, but the relay function of the neighbor node does not work also, communication with other nodes except the previous one is not possible.

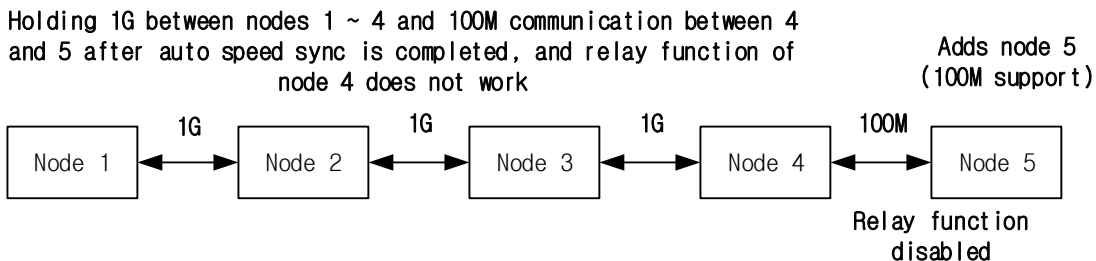

Notes

- (1) The optical module determines the link speed based on the Transceiver's 100M or 1G even when the media is set to AUTO. However, in case of the mixing module, if 100M Transceiver is connected to the optical port, if the electrical port is set to AUTO, the communication is connected to 100M according to the optical port speed.

## Chapter 5 High Speed link Service

### 5.1 Overview

HS link is a communication method between XGT PLC communication modules and can send and receive data periodically by setting HS link parameter. In XG5000, data can be send / received by setting send / receive data size, period, area and storage area in parameter.

High speed link is a service to send and receive at the end of PLC program when parameter is set. Therefore, when the send / receive cycle is short, the communication module transmits every scan data, which decreases the efficiency due to the increase of the traffic. The user can set the send / receive period from a minimum of 5 ms to a maximum of 10 seconds. The default is 200 ms.

However, since HS link service uses subnet broadcast service, it may affect other communication modules using the same network. Therefore, in order to maximize communication efficiency, the user can set the maximum send / receive size (400 bytes) that can be set per HS link block. This reduces the total number of blocks used and increases communication efficiency. The high speed link function is as follows.

(1) High speed link block setting function

- 1) High-speed link service is up to 12 XGK / I and 6 XGR.
- 2) Each HS link can be set to 32 blocks for sending and 128 blocks for receiving. If mixed, up to 128 blocks can be set. Up to 200 words can be set for each block.
- 3) When using high speed link extension mode, RAPIEnet V2 high speed link supports a maximum of 256 blocks x 700 words for transmission, a maximum of 256 blocks x 700 words for reception, and a maximum of 256 blocks x 700 words for transmission and reception.

(2) Send cycle setting function

User can set send / receive cycle for each module Send / receive cycle is set from 5ms to 10 seconds per module.

(3) Send and receive setting function

Set the send / receive area per data block according to the set I / O address.

(4) High speed link information provision function

It is easy to construct a reliable communication system by providing high speed link information with user keyword. It indicates the high speed link points. The setting unit per high speed link block is word (16 points).

Classification	Maximum send and receive points (Word)	Maximum send points (Word)	Maximum block number	Maximum points per block (Word)
Basic mode	25600	6400	128ea (0-127)	200
Extension mode (RAPIEnet V2)	179,200	179,200	256ea (0-255)	700

**Notes**

- 1) In Ethernet module version V5.0 or lower, the minimum send period setting unit of HS link service is 20ms..
- 2) FEnet Type: The maximum block number setting for receive is 32. By changing the receiving station number, up to 128 blocks of data can be received.
- 3) RAPIEnet (Basic mode): The block number can be set from 0 to 63. But the maximum number of transmission blocks is 32.
- 4) RAPIEnet (Extension mode): The block number can be set from 0 to 255. The maximum number of transmission blocks is 256.

5.2 HS link send / receive data processing

How to use High Speed Link is explained as a setting example when Ethernet module of station“0” and station“1” sends and receives data.

Station “0” sends 10 words of data in M0000 of block “0” and receives 10 words of data in M0010 of block 1 of station “1”. Station “1” receives 10 words of data from block 0 of station “0” to M0030 and sends 10 words of data from M0020 of block “1” of station “1”.

There are 32 block numbers from 0 to 31 for sending data and 128 from 0 to 127 for receiving in HS link parameter. When sending data, set the Read area and Block number to be read without specifying the destination station number.

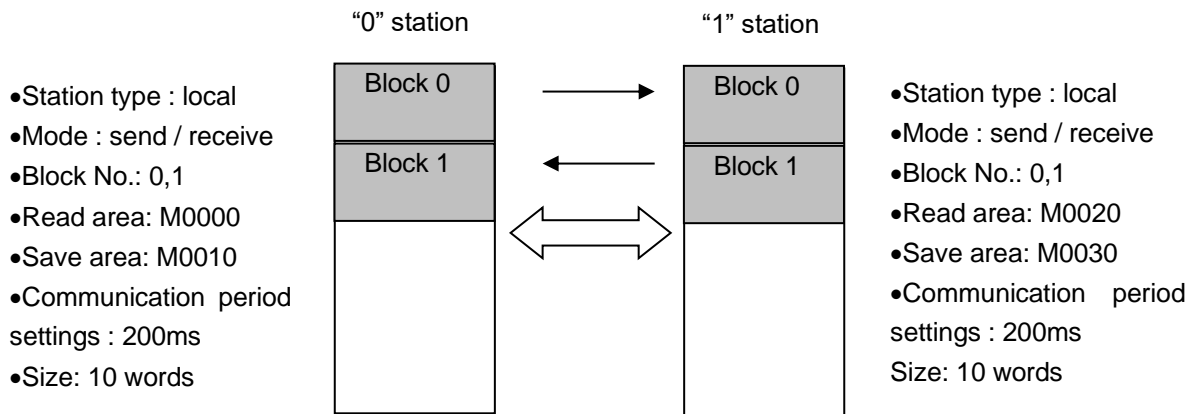

High-speed link send / receive processing is performed at the end of scan time If the high-speed link period is faster than scan, it is performed once at the end of scan.

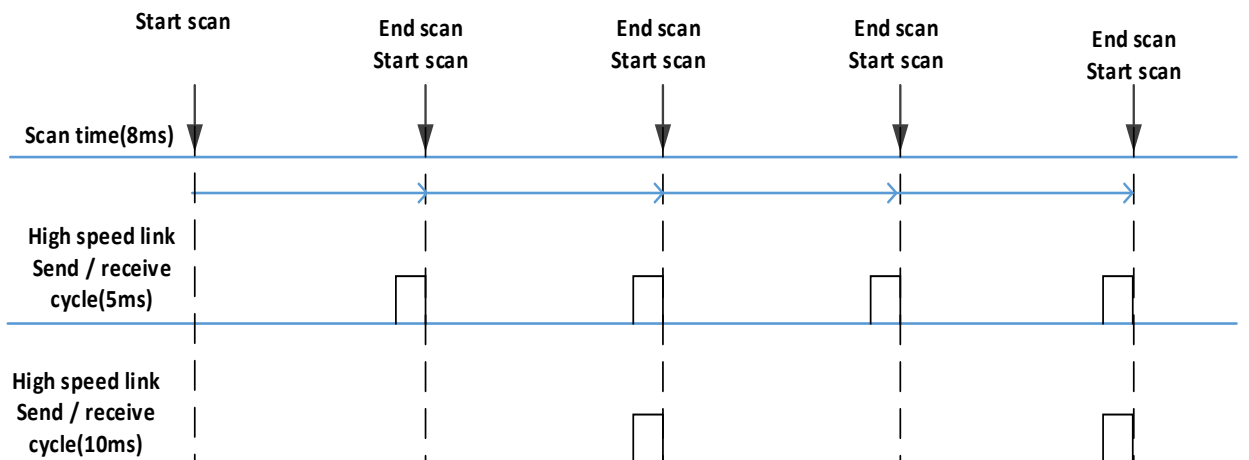

5.3 HS link setting

Select High Speed Link parameter and set the item. The setting order and function per item are as follows.

5.3.1 Standard settings

The following describes the Standard settings parameter needed high speed link service.

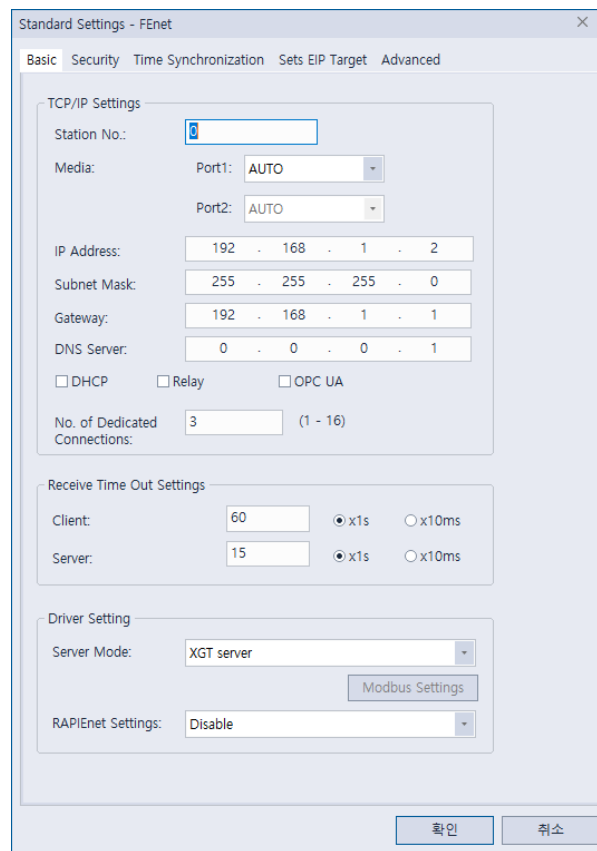

(1) Station No

In the high speed link service, the station number is used as the station number of Ethernet (master) when using RAPIEnet protocol communication with the Communication device.

(2) RAPIEnet setting

Service operation depends on the RAPIEnet settings in the driver settings of the Standard settings window.

RAPIEnet setting	HS Link Service operation
Disable	Only Ethernet protocol is available.
RAPIEnet v1	Only RAPIEnet v1 protocol is available.
RAPIEnet v2	Only RAPIEnet EtherNet / IP protocols is available. If RAPIEnet protocol is used, ring configuration and High Speed communication between own networks are possible.

5.3.2 HS Link Service

(1) Parameter setting method for high speed link

1) Click the Project tap on the left [Project] window and select by right clicking on the communication module item on the tree.

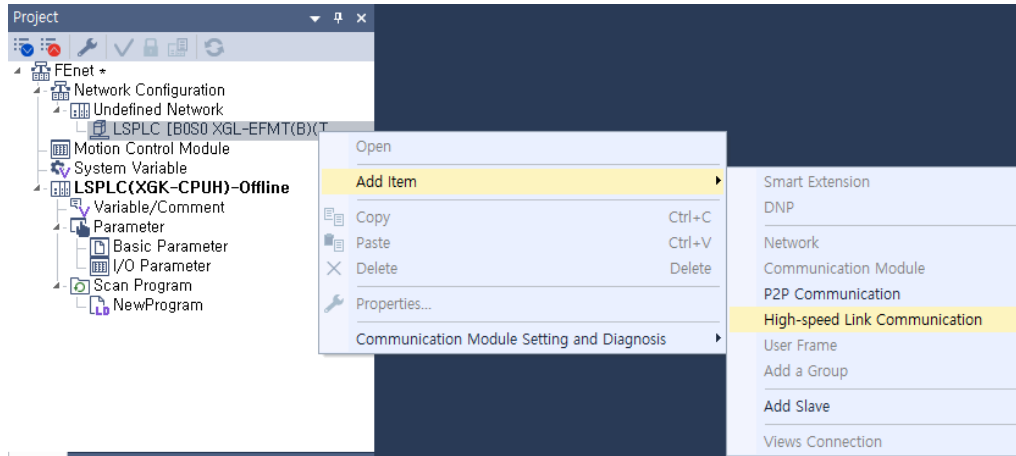

2) Click the View High-speed Link tab on the left [Project] window and select by right clicking on the PLC item on the tree.

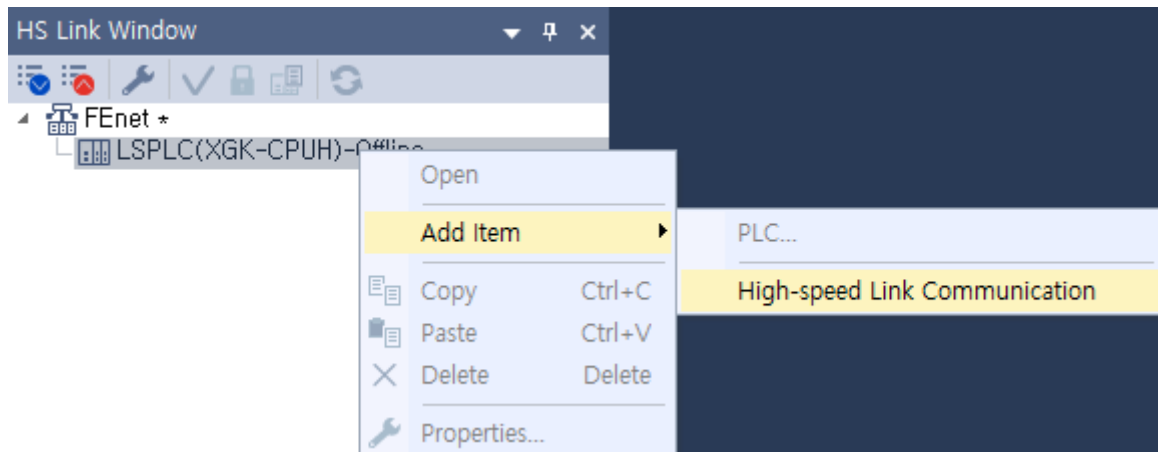

(2) Communication module setting

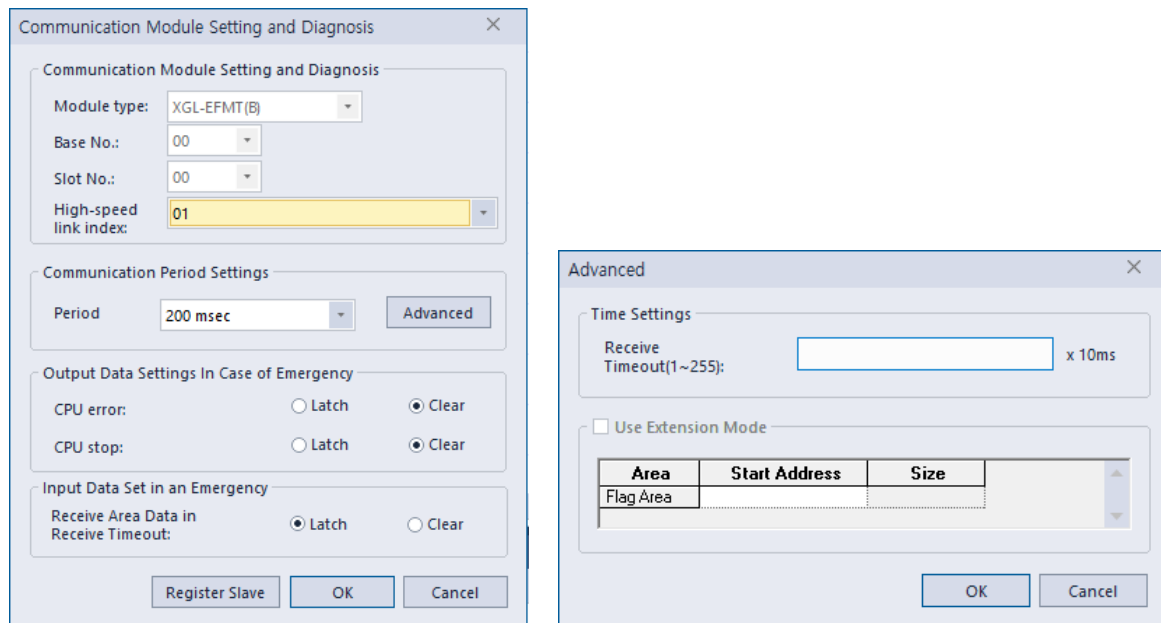

Classification		Content
Communication module setting	Module type	Register Ethernet module.
	Base Number	Base number where Ethernet module is mounted.
	Slot No.	Slot number where Ethernet module is mounted.
	High speed link number	Set the high-speed link number from 1 to 12.
Communication period settings	Period type	It can be set from 5ms to 10sec in communication cycle. - The send cycle is only for blocks set to send. - The transmission period is equally applied to the entire transmission block within one HS link parameter.
Advanced	Receive Timeout	If it is not received within the set time, an error is processed. (OS V8.3 or later)
	Use Extension Mode	When set, RAPIEnet V2 high-speed link supports a maximum of 256 blocks x 700 words for transmission/reception/total blocks. (OS V8.7 or later)
Output data settings in case of emergency	CPU error	Latch: It keeps and transmits the latest data received from the CPU. Even if it is set to latch, it may appear to be cleared by giving data to the CPU before the error. Clear: Clear Ignores the data received from the CPU and sets HS link send data to 0 for transmission. Even if the emergency output data setting of the device area of the high speed link sending side is set to latch in the CPU, the data set to 0 is transmitted when set to clear in the emergency output data setting of XG5000 high speed link setting.
	CPU stop	
Input Data Set in an Emergency	Receive Area Data in Receive Timeout	Latch: Retains the last received data when a reception timeout occurs. Clear: When a reception timeout occurs, the reception area is cleared to "0". (OS V9.0 or later)
Slave Registration*1 (V6.0 or higher)		Select Smart I/O block to be registered in HS link.

\* 1 is used when high speed linking with Smart I / O block of RAPIEnet v1 version after specifying RAPIEnet v1 in Ethernet basic setting.

(3) Screen after selecting communication module

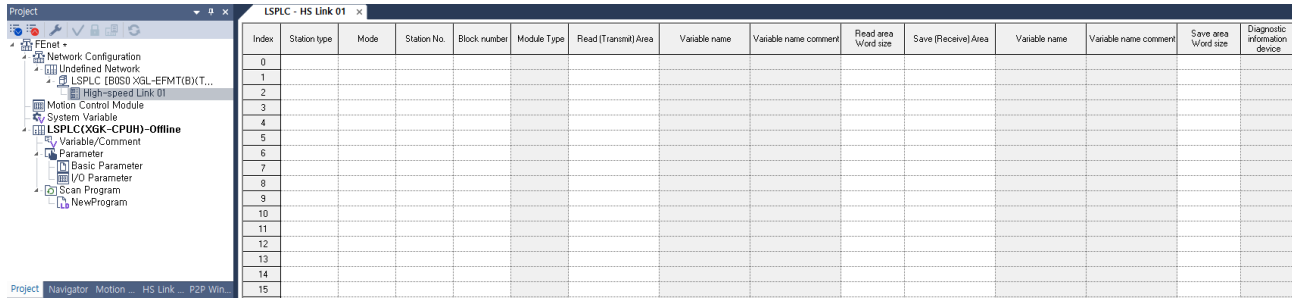

Classification		Content
Station type	FEnet	Select for Ethernet high speed link communication.
	RAPIEnet	Select for RAPIEnet high speed link communication. The driver setting must be set to RAPIEnet in the Standard settings.
	RAPIEnet Remote *1	RAPIEnet Select to control Smart I/O block with high speed link. RAPIEnet Smart I/O block can be set by loading slave in HS link parameter after setting in slave configuration screen. However, RAPIEnet v1 must be enabled in Standard settings.
Mode	Send	Send data.
	Receive	Receives data.
	Send/Receive*1	It is automatically input when connected to I / O mixed module slave of RAPIEnet Smart I/O block. (Ethernet V6.0 or higher)
Station No	Send means the module station number of own station, and when receiving, it means the module number of other station. If the station type is FEnet, the range is '0~63', and if the station type is RAPIEnet, the range is '0~220'. 'Do not use duplicated station number because it is ' own station' or unique number that distinguishes communication module in the same network system.	
Block number	Set the send / receive block. * RAPIEnet Smart I/O block is automatically set to the same station number and block number.	
Read area	Memory area of own module. Available memory area. 1) XGK: P,M,K,F,T,C,U,Z,L,N,D,R,ZR 2) XGI/XGR: M,I,Q,R,W For the size and range of each memory area, refer to the XGT CPU memory device list in the Appendix.	
Variable	The variable name of the device set in the read area is displayed.	
Variable Comment	The variable comment of the device set in the read area is displayed.	
Read area Word size	Set the data size to be sent in words.	
Save area	This area is to receive and store data from the destination station. 1) XGK: P,M,K,F,T,C,U,Z,L,N,D,R,ZR 2) XGI/XGR: M,I,Q,R,W For the size and range of each memory area, refer to the Synchronous start XGT CPU memory device list in the Appendix.	
Variable	The variable name of the device set in the save area is displayed.	
Variable Comment	The variable comment of the device set in the save area is displayed..	
Save area Word size	Set the data size to be receive in words	
Diagnostic information device	Displays the diagnostic information device when the use diagnostic area option of the registered slave is enabled.	

\* 1 is used when high speed linking with Smart I / O block of RAPIEnet v1 version after specifying RAPIEnet v1 in Ethernet basic setting.

### Notes

- (1) RAPIenet driver can be set in Ethernet (V6.0 or higher).
- (2) RAPIenet Remote is set automatically when connecting RAPIenet Smart I / O block as slave.
- (3) The send / receive mode is set when connecting RAPIenet Smart I / O block.
- (4) High-speed link service between Ethernet (master) and expansion driver / Smart I / O expansion / Smart I / O block (slave) is available only in Smart I / O block RAPIenet v1 version. The rest of the slaves are not supported.  
It is supported as a slave module (expansion driver / Smart I / O extension type / Smart I / O block type) and smart extension service with Ethernet (V8.0 or higher) as RAPIenet v2 driver, and high-speed link service is not supported.

### (4) Write high-speed link parameters

- 1) Select [Online]→ [Write] on menu.

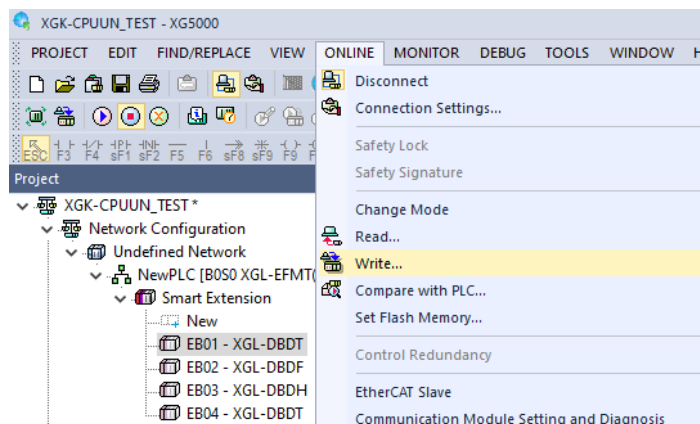

- 2) Check the relevant HS link in [Write] window and press OK button.

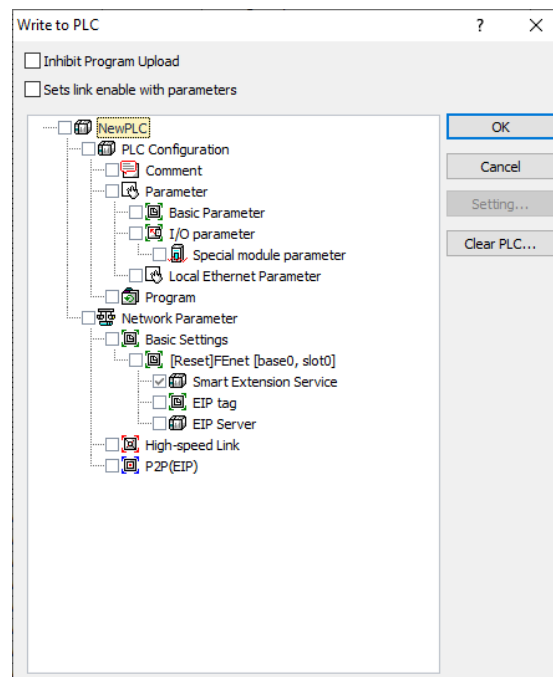

(5) High-speed link parameters read

1) Select [Online]→ [read] on menu.

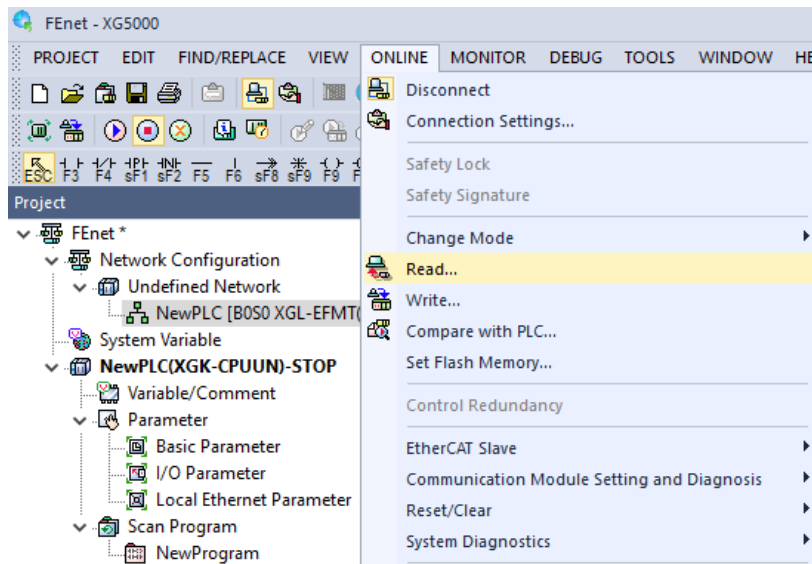

2) Check the relevant HS link in [read] window and press OK button.

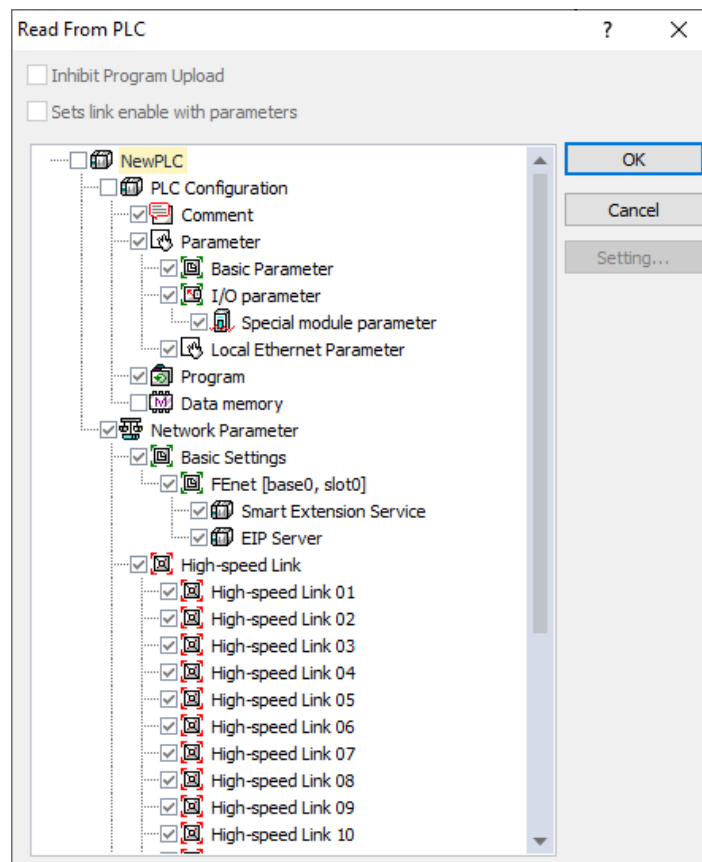

### (6) Downloading parameter

- 1) Select [Online]→ [Write] of XG5000 to open the screen below. Check the setting parameters and click the OK button.
- 2) After downloading the Standard Settings parameters, the PLC power must be Off-> On or reset. If you do not reset the communication module, the new communication parameter information will not be applied.

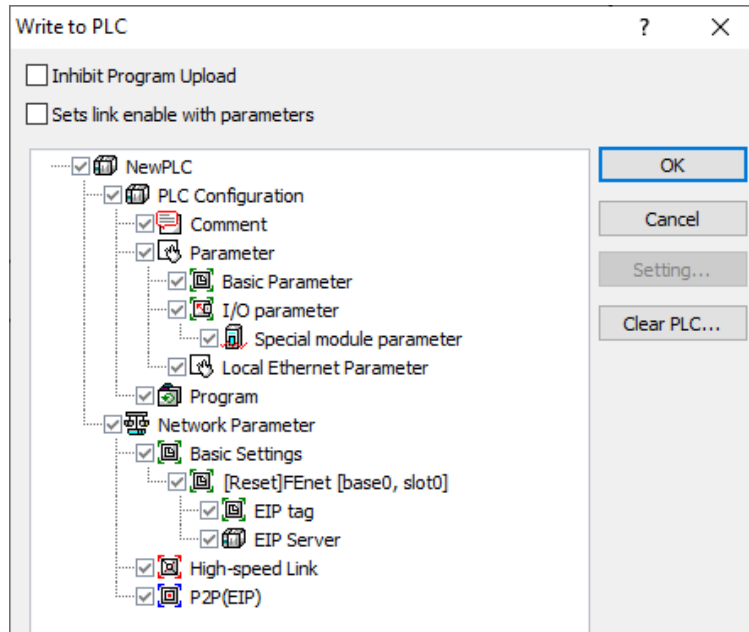

5.3.3 Communication device configuration (Smart I / O block v1 version)

When using Smart I / O block RAPIenet v1 driver, the following settings are possible. Set RAPIenet setting as below in standard settings.

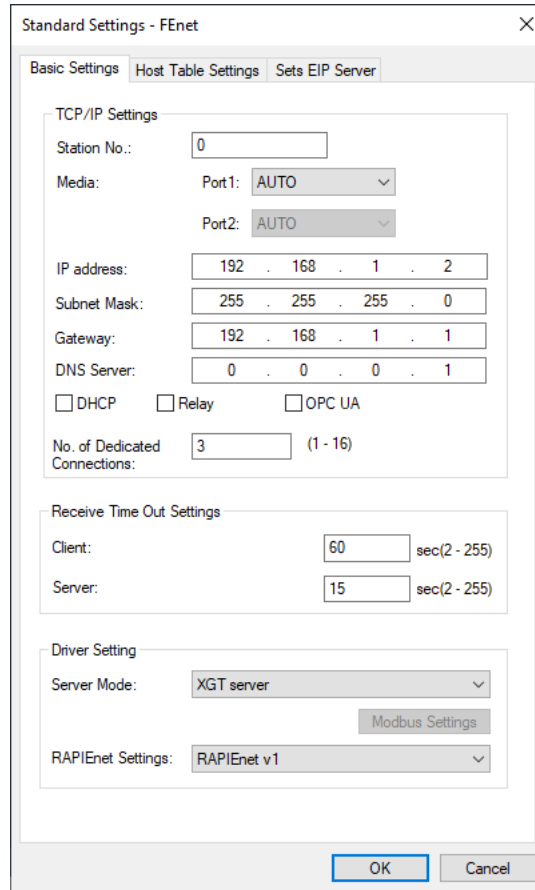

Select the newly registered Ethernet (XGL-EFMx) module on the network configuration screen and right-click to select the [Add Item]→ [Add Slave] menu. Alternatively, select [Project] → [Add Item] → [Add Slave] on the XG5000 menu to perform the same function.

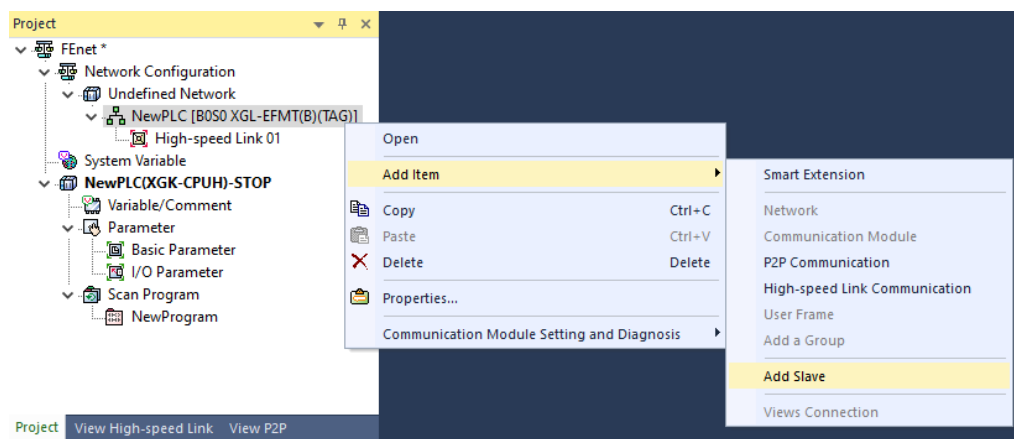

(1) Slave configuration window

RAPIenet Smart I/O block module is a slave module. To communicate with master module, parameter for each slave must be set. The configuration window for the slave configuration is shown below.

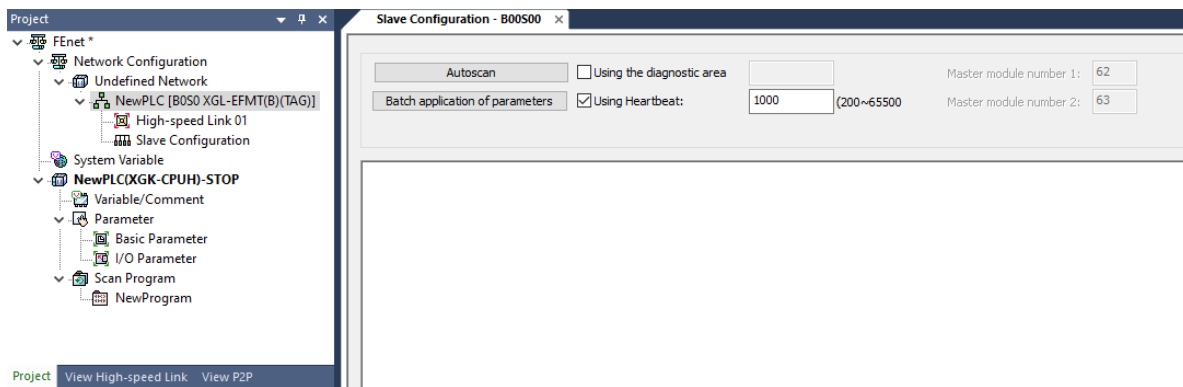

### 1) Auto scan(Slave Registration)

This item is activated only when there is an online connection to the PLC. By clicking Auto Scan, you can add Smart I O block that is not occupied by other master modules. Clicking Add Auto Scan Slave creates a list of slaves that can be added from the network.

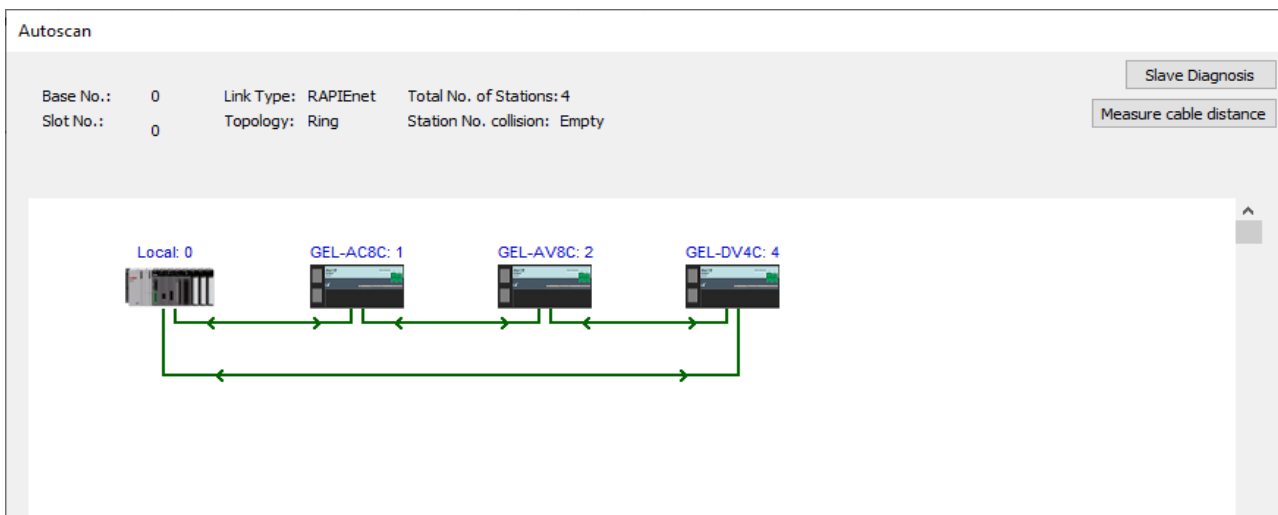

Name	Meaning
Standard information	It means the network configuration information of master (local) number. Displays the base number and slot number.
Add Slave	It is a function to select the module to control among the Smart I / O block modules existing in the network at the master station (Local).

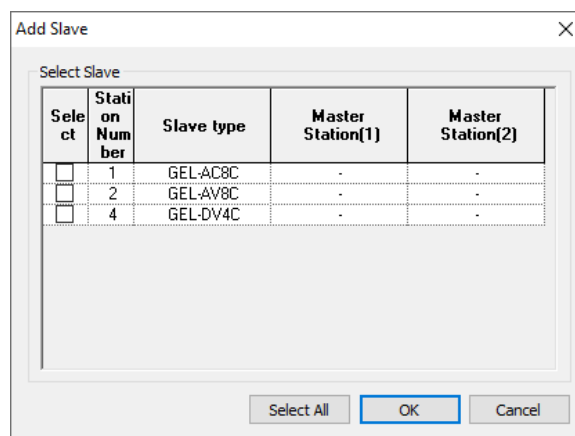

Notes

1) If you click the Add Slave button, you can add only for Smart I / O block with no parameters. If the slave to be selected in the slave add window is controlled by another master module, the slave cannot be selected.

2) Apply all parameters

This function is used when applying all the modules according to the module type. In the system consisting of Smart I / O block, parameters for each module can be applied collectively, reducing the parameter setting time.

The 'Apply All' dialog box shows the following settings for a GEL-AC8C module:

- Slave Selection: GEL-AC8C
- Product Name: GEL-AC8C
- Station: -
- Input Module:
  - High-speed link transfer mode: Cyclic
  - High-speed link frequency(msec): 200
  - Minimum transmission prohibition time (msec): 200
  - Data Transfer:  Broadcast  Unicast
  - Input Filter(msec): 3
- Output Module:
  - Emergency output mode: Latch

Buttons: Apply(A), Close(C)

The 'Apply All' dialog box displays a table of parameters for each channel (CH 0 to CH 7) of a GEL-AC8C module. The table is as follows:

Parameter	CH 0	CH 1	CH 2	CH 3	CH 4	CH 5	CH 6	CH 7
<input type="checkbox"/> Operation Channel	Disable	Disable	Disable	Disable	Disable	Disable	Disable	Disable
<input type="checkbox"/> Input Range Setting	4~20mA	4~20mA	4~20mA	4~20mA	4~20mA	4~20mA	4~20mA	4~20mA
Output Data Type	0~16000	0~16000	0~16000	0~16000	0~16000	0~16000	0~16000	0~16000
<input type="checkbox"/> Filter Status Setting	Disable	Disable	Disable	Disable	Disable	Disable	Disable	Disable
Filter Constant Value	1	1	1	1	1	1	1	1
<input type="checkbox"/> Averaging Method Settin	Disable	Disable	Disable	Disable	Disable	Disable	Disable	Disable
<input type="checkbox"/> Average Method Setting	Count-Avr	Count-Avr	Count-Avr	Count-Avr	Count-Avr	Count-Avr	Count-Avr	Count-Avr
Average Value	2	2	2	2	2	2	2	2
<input type="checkbox"/> Hold Last Value	Disable	Disable	Disable	Disable	Disable	Disable	Disable	Disable

Buttons: Apply(A), Close(C)

The functions of each menu are as follows.

Name	Meaning
Select Slave	It means the module to apply the parameter batch application function.
Basic Parameter	It means the basic parameter of module.
Module Parameter	In case of module parameter, it is active only when analog input / output module is selected.
Apply	The set parameters are applied.

### 3) Using the diagnostic area

Using the diagnostic area function is to transmit diagnostic information provided from slave module to PLC device area. Check using the diagnostic area and input the start address of PLC device where the diagnostic information will be saved. The diagnosis area of 1 word per slave is automatically allocated to HS link block.

### 4) Using Heartbeat

It is a function to check if there is a network drop between the RAPIenet Smart I / O block and master. It checks the presence of the network by checking the heartbeat signal periodically every set time. The heartbeat setting cycle is available from 200ms to 65500msec. If you check the use of diagnostic area, you can get the information of each smart I / O block heartbeat error.

### 5) Master module number

This function is activated when Smart I / O block is used in XGR CPU. It means the station number of the master of XGR CPU and the master module settled on standby Smart I/O block connects only the data of XGR master side to the output.

## (2) System catalog EDS information(slave registration)

It contains basic parameter information about Smart I/O block module and module parameter information. If you double-click Smart IO to use or drag-in to slave configuration window, parameter setting window of selected module is created.

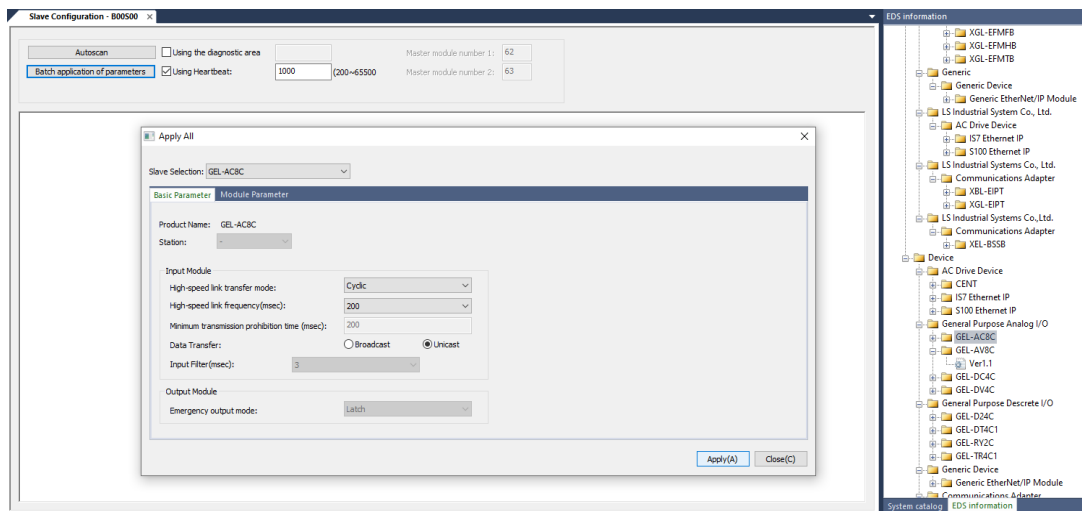

### 1) Basic parameter setting

Basic parameter means communication basic parameter setting for communication between Smart I / O block module and master. Setting method is drag-in or double click slave module to configuration window from catalog menu of slave configuration window. Basic parameters are divided into station number information and setting items related to input module output module, and setting items are automatically activated according to module type.

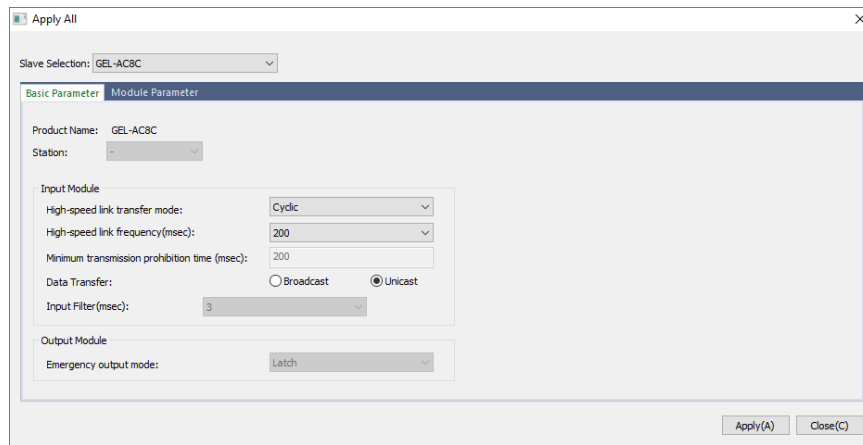

Name	Meaning
Product name	Displays the product name of the Smart I / O block module.
Station No	This menu is used to set Smart I / O station No. 0 ~ 63. It must match the station number of the module on the network.
High-speed link transfer mode	Cyclic: It is used when the slave sends the input data to the master periodically. CoS: Used to send data only when the input status changes. If data changes are slow, applying CoS can reduce the network load.
High-speed link transfer cycle	Only applicable for slaves with inputs. Only active when the HS link send mode is Cyclic mode. The send cycle is as follows. Setting range : 5~1000(default: 200)
Minimum send prohibit time	This function is activated when the high speed link send mode of the slave is CoS. It means the minimum interval for send mode in CoS. Frequent data transfers on a periodic basis will affect the overall network load on the system. Therefore, if the data of input module occurs frequently and aperiodically, the data is transmitted only when the input value is changed at the set time interval.
Data Transfer method	Broadcast: When you send data, not send the data to a specific receiver, but to all devices connected to that network. Unicast: This is the most commonly used one-to-one communication method.
Input filter	This function is activated only when the digital input module is used. The input filter function is supported to prevent input of invalid values by external noise. Input the data as valid data only when the data is kept above the input filter value set. Set the input filter value considering the environment. Setting range : 1~100(default: 3)
Emergency Output Mode	This function is activated only when the output module type is used. If the network configuration is disconnected during normal communication with the master module, the existing output data can be set to latch and clear mode. Latch: Maintain existing output data when physical communication with the master module is disconnected. Clear (default): Initializes the existing output data to 0 when physical communication with the master module is disconnected. The transmission cycle of the output module depends on the communication cycle setting in [Communication module setting]

### Notes

- (1) When the data of input module is changed in 2ms unit, it is the calculation method of network load according to minimum send prohibition time.
  - 1) When the minimum send prohibition time is set to 2 ms
    - Packets per second (pps) =  $1 / 0.002 = 500\text{pps}$
    - 5,000 pps with 10 modules of the same condition
  - 2) When the minimum send prohibition time is set to 200ms
    - Packets generated per second (pps) =  $1 / 0.2 = 5\text{pps}$
    - 50pps with 10 modules of the same condition
- (2) If the data change interval of input module is shorter than the minimum High Speed Link send period (5ms), High Speed Link send mode is recommended as Cyclic mode for stable system operation.

### 2) Module parameter settings

Module parameter is a window to set basic information necessary to operate Smart I / O block special module connected to network. For detailed parameters, refer to parameter setting of each product.

### (3) High-speed link parameters setting

- 1) Click the Project tap on the left [Project] window and select “High-speed Link Communication” by right clicking on the communication module item on the tree.

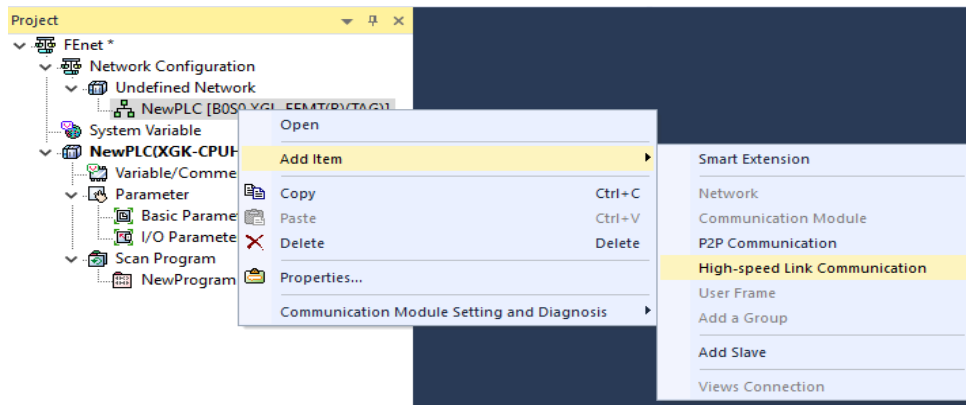

### 2) HS link block setting(slave)

Right-click on [High-speed Link 01] in the [Project Window]. When [Properties] → [Communication module setting and Diagnosis] window is displayed, click [Register slave] and the [Apply RAPIenet slave configuration] window appears. Click after selecting the slave to apply.

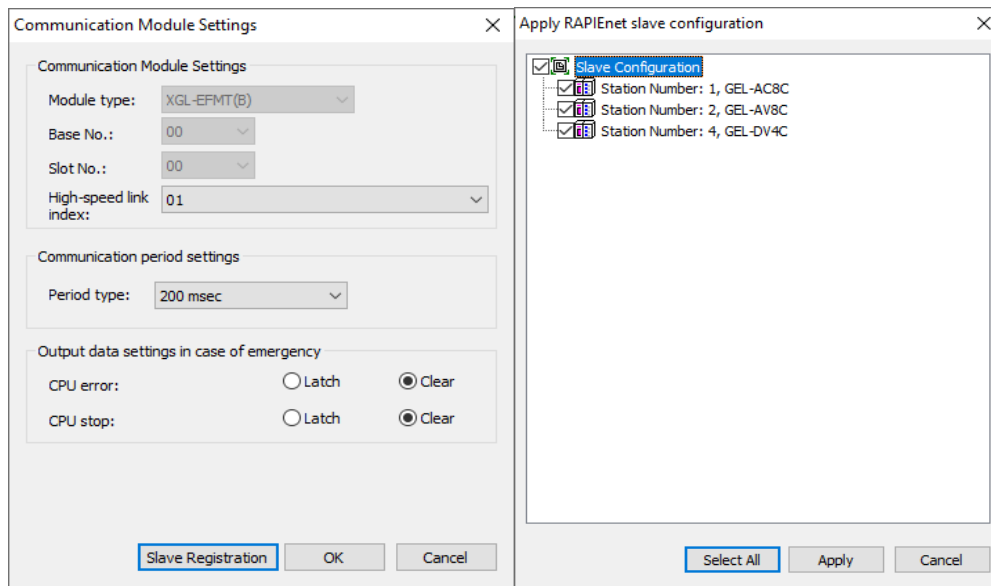

**Notes**

Even if it is necessary to change the slave list in the HS link block according to the network system change, click Slave Registration to select the slave to be used and click Apply.

3) HS link block setting(slave)

If you double-click High-speed Link item on High-speed Link view tab, the following parameter registration window is created.

Set the area to read and save.

Index	Station type	Mode	Station number	Block number	Module type	Read area	Variable name	Variable name comment	Read area Word size	Save area	Variable name	Variable name comment	Save area Word size	Diagnostic information device
0	RAPIenet Remote	2. Receive	2	2	GEL-AV8C					M0010			8	
1	RAPIenet Remote	1. Send	4	4	GEL-DV4C	M0000			4					
2														

(4) Downloading the high speed link parameter

After completing HS link parameter setting, select [Online] → [Write (Basic setting, HS link, P2P)] in XG5000 and check the HS link and click OK button.

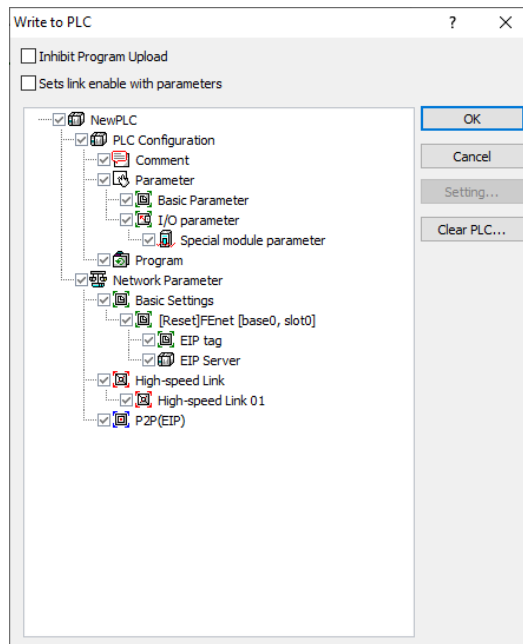

(5) High-speed link parameters enable

Select [Online] → [Communication module setting and diagnosis] → [Enable services] in XG5000 and check the corresponding high speed link and click the write button. When HS link is enabled, HS LED is turned on in the LED display of the module to start HS link.

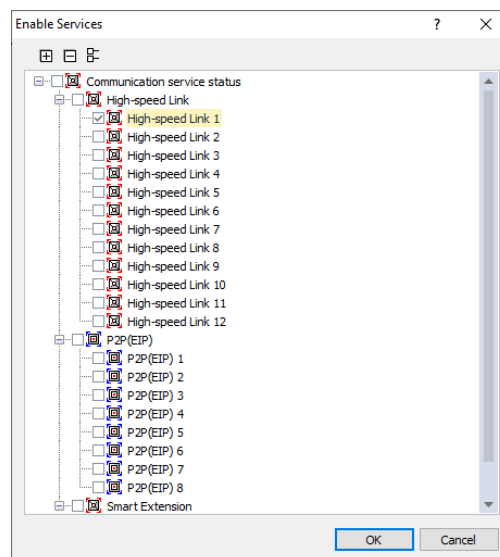

5.4 HS Link operation

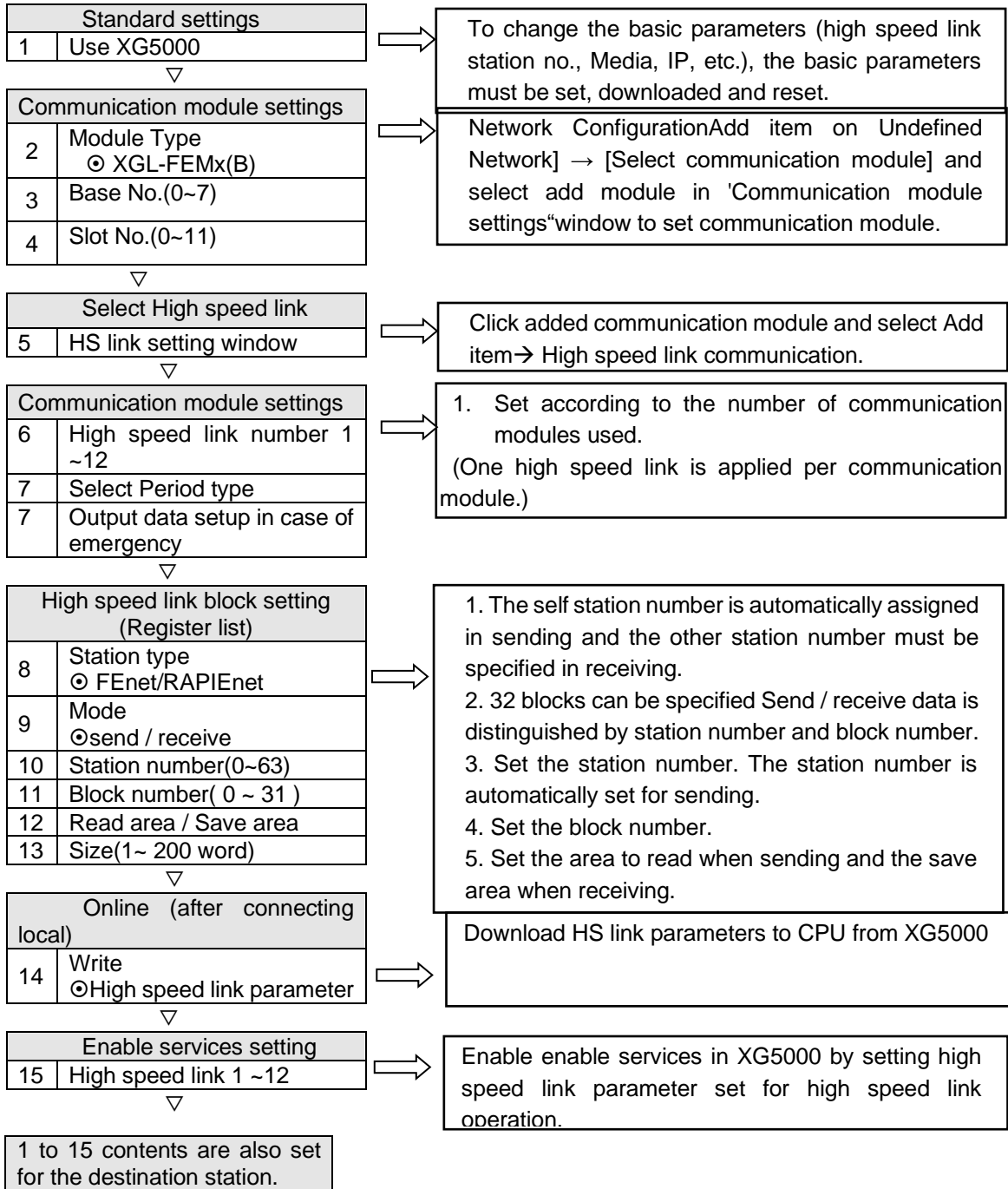

Notes

- 1) V5.0 or less: The period type of communication period setting can be set from 20ms to 10sec.
- 2) HS link number can be set from 1 ~ 12. The parameter should be set using one HS link number per module to prevent collision of communication data.

(1) HS Link Service Operation

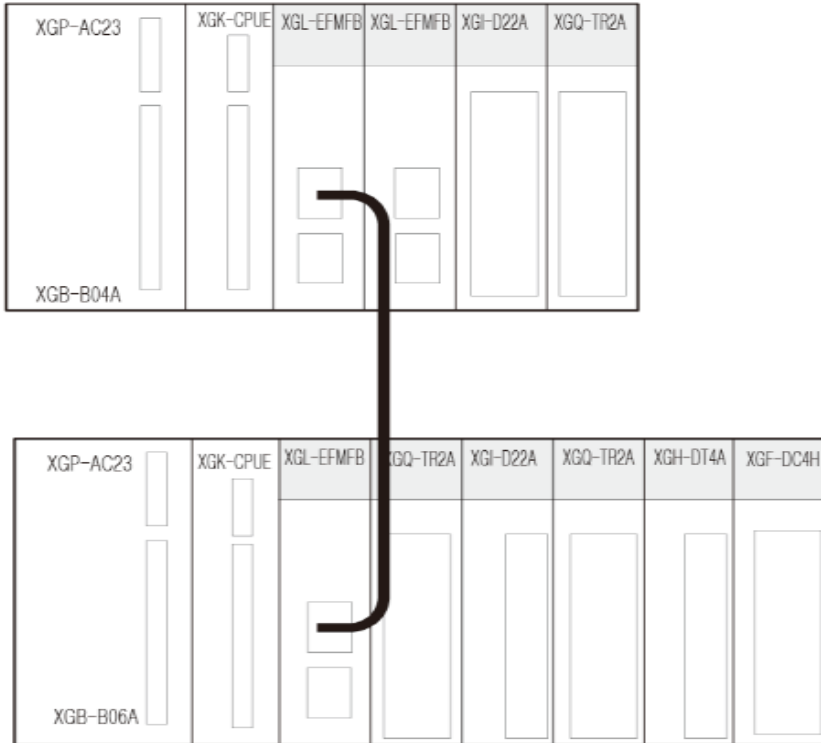

How to use High Speed Link is explained as a setting example when Ethernet module of station "0" and station "1" sends and receives data.

"Station 0" transmits two words of M0000 in block "0" and the data received from station "1" is stored in M0010. "Station 1" receives M0000 2 words of station "0" stores them in M0010, and transmits 2 words of M0000 data in block "1"

When sending, specify the area to be read and the sending block without specifying the destination station number.

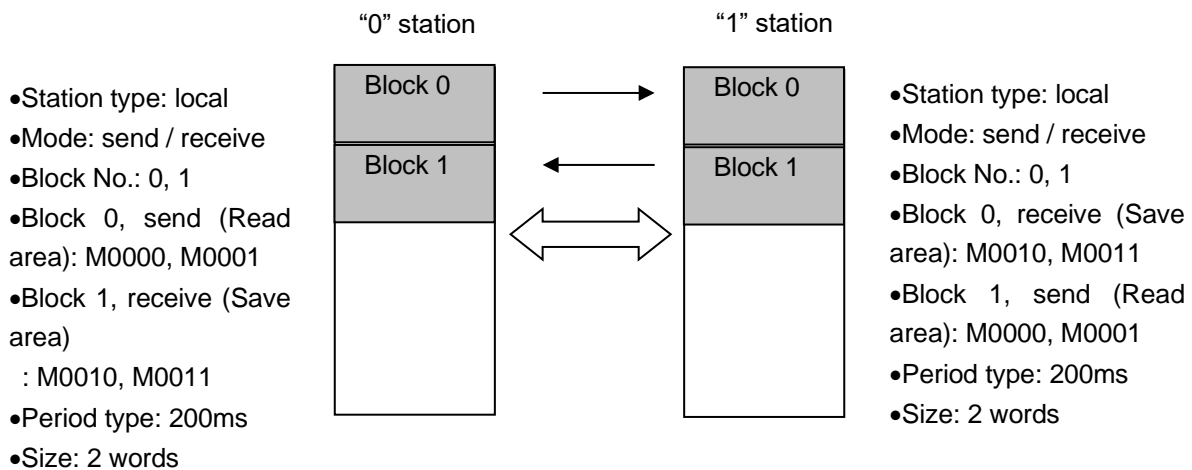

Program sequence: Connect to PLC system 1, 2 CPU and set in the following order. Set system 1 as station number 0 and system 2 as station number 1.

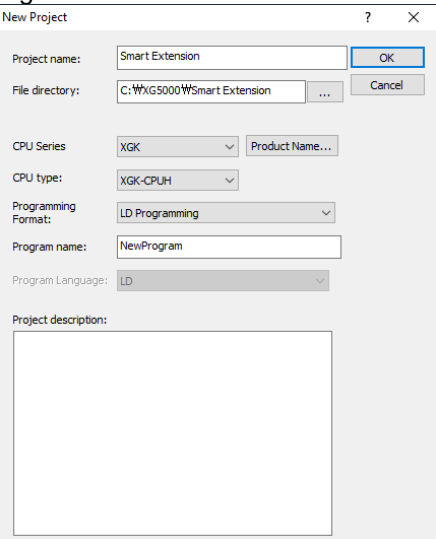
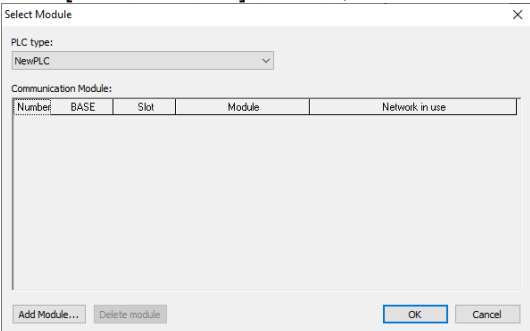
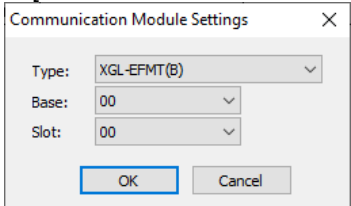
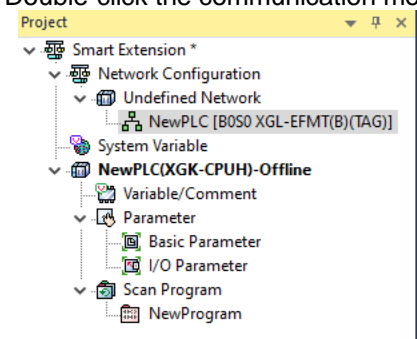
Sequence	Setting process	Setting method
1	Create new project	<p>1) [Project]→Open [New Project] and enter the project name, CPU series, CPU type, programming type, and program name.</p> 
2	Undefined Network Add	<p>1) Select [Undefined Network]→[Add item]→ [Communication module].                  2) In the [Select Module] window, click "Add module".</p>  <p>1) Set Type, Base and Slot in Communication module settings. After that, select OK button in [Communication module selection] and module setting is completed.</p> 
3	Standard settings	<p>Double-click the communication module in the [Project] window.</p> 

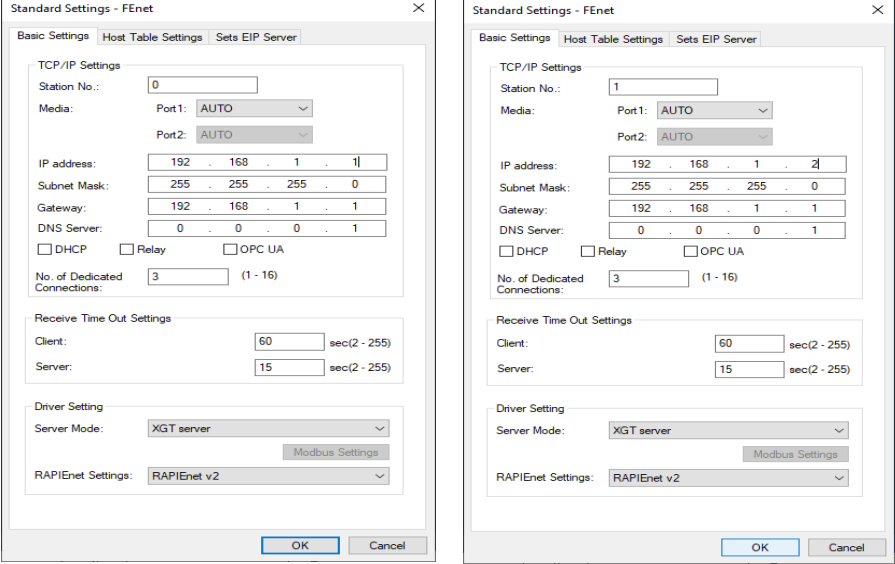
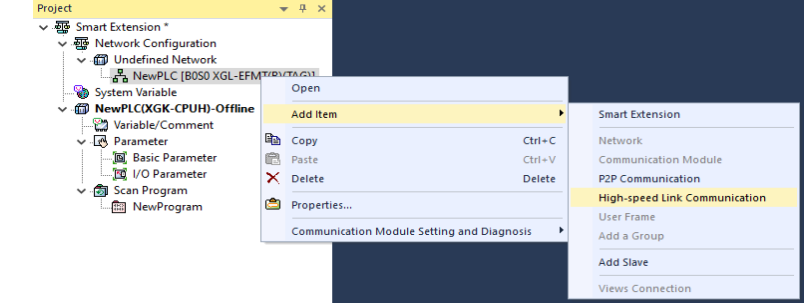
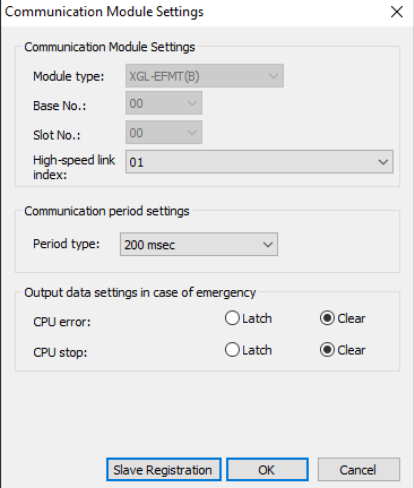
Sequence	Setting process	Setting method
3	Standard settings	<p>Set TCP / IP Settings, Receive time out Settings, and Driver settings on the [Basic Settings] tab.</p> <p>1) Station No.0: set station number 0 and IP address                      2) Station No.1: set station number 1 and IP address to a station number different from station number 0.</p> 
4	HS link setting	<p>Click [Project]→[Add item]→[High speed link communication].</p>  <p>From the Communication module settings window, select the high speed link index, communication period and output data settings in case of emergency, and then click the [OK] button.</p> 

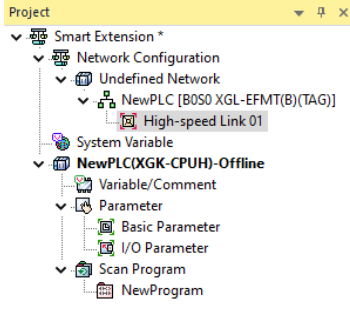
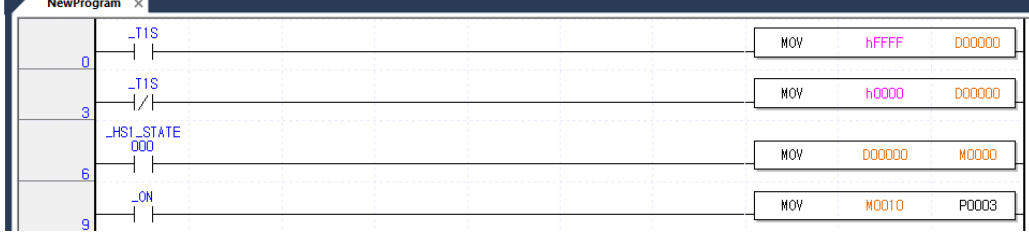
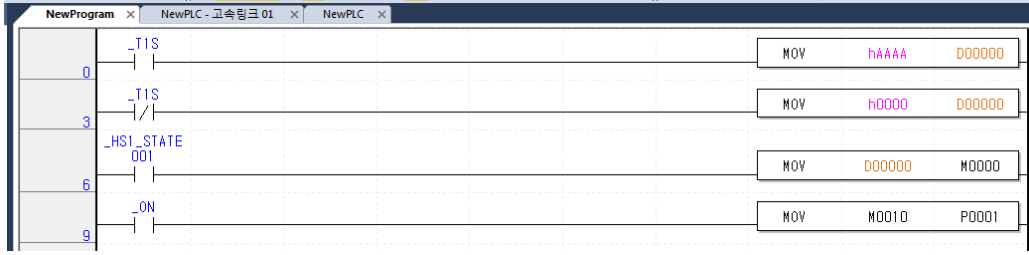
Sequence	Setting process	Setting method																																																																																																																																																																																																					
4	HS link setting	<div data-bbox="480 402 1500 715">  <table border="1" data-bbox="839 425 1500 715"> <thead> <tr> <th>Index</th> <th>Station type</th> <th>Mode</th> <th>Station number</th> <th>Block number</th> <th>Module type</th> <th>Read area</th> </tr> </thead> <tbody> <tr><td>0</td><td></td><td></td><td></td><td></td><td></td><td></td></tr> <tr><td>1</td><td></td><td></td><td></td><td></td><td></td><td></td></tr> <tr><td>2</td><td></td><td></td><td></td><td></td><td></td><td></td></tr> <tr><td>3</td><td></td><td></td><td></td><td></td><td></td><td></td></tr> <tr><td>4</td><td></td><td></td><td></td><td></td><td></td><td></td></tr> <tr><td>5</td><td></td><td></td><td></td><td></td><td></td><td></td></tr> <tr><td>6</td><td></td><td></td><td></td><td></td><td></td><td></td></tr> <tr><td>7</td><td></td><td></td><td></td><td></td><td></td><td></td></tr> <tr><td>8</td><td></td><td></td><td></td><td></td><td></td><td></td></tr> <tr><td>9</td><td></td><td></td><td></td><td></td><td></td><td></td></tr> </tbody> </table> </div> <p data-bbox="508 722 1053 752">Double-click HS link 01 in the [Project] window.</p> <p data-bbox="480 759 1500 792">1)Block 0 send and block 1 receive of Station No. 0(Block 1 send data of station No. 1)</p> <div data-bbox="508 799 1500 892"> <table border="1"> <thead> <tr> <th>Index</th> <th>Station type</th> <th>Mode</th> <th>Station number</th> <th>Block number</th> <th>Module type</th> <th>Read area</th> <th>Variable name</th> <th>Variable name comment</th> <th>Read area Word size</th> <th>Save area</th> <th>Variable name</th> <th>Variable name comment</th> <th>Save area Word size</th> <th>Diagnostic information device</th> </tr> </thead> <tbody> <tr><td>0</td><td>FNet</td><td>1. Send</td><td>0</td><td>0</td><td></td><td>M0000</td><td></td><td></td><td>2</td><td></td><td></td><td></td><td></td><td></td></tr> <tr><td>1</td><td>FNet</td><td>2. Receive</td><td>1</td><td>1</td><td></td><td></td><td></td><td></td><td></td><td>M0010</td><td></td><td></td><td>2</td><td></td></tr> <tr><td>2</td><td></td><td></td><td></td><td></td><td></td><td></td><td></td><td></td><td></td><td></td><td></td><td></td><td></td><td></td></tr> </tbody> </table> </div> <p data-bbox="480 908 1500 941">2)Block 0 receive(Block 0 send data of station No.0) and block 1 send of Station No. 1</p> <div data-bbox="508 948 1500 1041"> <table border="1"> <thead> <tr> <th>Index</th> <th>Station type</th> <th>Mode</th> <th>Station number</th> <th>Block number</th> <th>Module type</th> <th>Read area</th> <th>Variable name</th> <th>Variable name comment</th> <th>Read area Word size</th> <th>Save area</th> <th>Variable name</th> <th>Variable name comment</th> <th>Save area Word size</th> <th>Diagnostic information device</th> </tr> </thead> <tbody> <tr><td>0</td><td>FNet</td><td>1. Send</td><td>1</td><td>1</td><td></td><td>M0000</td><td></td><td></td><td>2</td><td></td><td></td><td></td><td></td><td></td></tr> <tr><td>1</td><td>FNet</td><td>2. Receive</td><td>0</td><td>0</td><td></td><td></td><td></td><td></td><td></td><td>M0010</td><td></td><td></td><td>2</td><td></td></tr> <tr><td>2</td><td></td><td></td><td></td><td></td><td></td><td></td><td></td><td></td><td></td><td></td><td></td><td></td><td></td><td></td></tr> </tbody> </table> </div>	Index	Station type	Mode	Station number	Block number	Module type	Read area	0							1							2							3							4							5							6							7							8							9							Index	Station type	Mode	Station number	Block number	Module type	Read area	Variable name	Variable name comment	Read area Word size	Save area	Variable name	Variable name comment	Save area Word size	Diagnostic information device	0	FNet	1. Send	0	0		M0000			2						1	FNet	2. Receive	1	1						M0010			2		2															Index	Station type	Mode	Station number	Block number	Module type	Read area	Variable name	Variable name comment	Read area Word size	Save area	Variable name	Variable name comment	Save area Word size	Diagnostic information device	0	FNet	1. Send	1	1		M0000			2						1	FNet	2. Receive	0	0						M0010			2		2														
Index	Station type	Mode	Station number	Block number	Module type	Read area																																																																																																																																																																																																	
0																																																																																																																																																																																																							
1																																																																																																																																																																																																							
2																																																																																																																																																																																																							
3																																																																																																																																																																																																							
4																																																																																																																																																																																																							
5																																																																																																																																																																																																							
6																																																																																																																																																																																																							
7																																																																																																																																																																																																							
8																																																																																																																																																																																																							
9																																																																																																																																																																																																							
Index	Station type	Mode	Station number	Block number	Module type	Read area	Variable name	Variable name comment	Read area Word size	Save area	Variable name	Variable name comment	Save area Word size	Diagnostic information device																																																																																																																																																																																									
0	FNet	1. Send	0	0		M0000			2																																																																																																																																																																																														
1	FNet	2. Receive	1	1						M0010			2																																																																																																																																																																																										
2																																																																																																																																																																																																							
Index	Station type	Mode	Station number	Block number	Module type	Read area	Variable name	Variable name comment	Read area Word size	Save area	Variable name	Variable name comment	Save area Word size	Diagnostic information device																																																																																																																																																																																									
0	FNet	1. Send	1	1		M0000			2																																																																																																																																																																																														
1	FNet	2. Receive	0	0						M0010			2																																																																																																																																																																																										
2																																																																																																																																																																																																							
5	programming	<p data-bbox="480 1078 1500 1199">1) Station No. 0 program: Sends M0000 (hFFFF and h0000 values changed every 500ms) and M0001 value 2 word data to high speed link 01 as block 0, and outputs M0010 to P0003 of M0010 and M0011 data received as block 1 of station number 1 to high speed link 01.</p> <div data-bbox="480 1206 1500 1438">  </div> <p data-bbox="480 1471 1500 1591">1) Station No. 1 program: Sends M0000 (hAAAA and h0000 values changed every 500ms) and M0001 value 2 word data to high speed link 01 as block 1, and outputs M0010 to P0001 of M0010 and M0011 data received as block 0 of station number 0 to high speed link 01.</p> <div data-bbox="480 1622 1500 1877">  </div>																																																																																																																																																																																																					

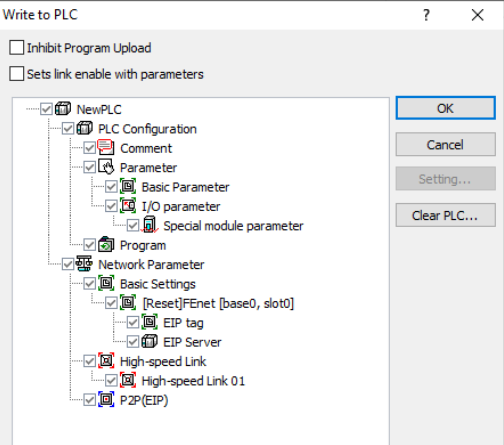
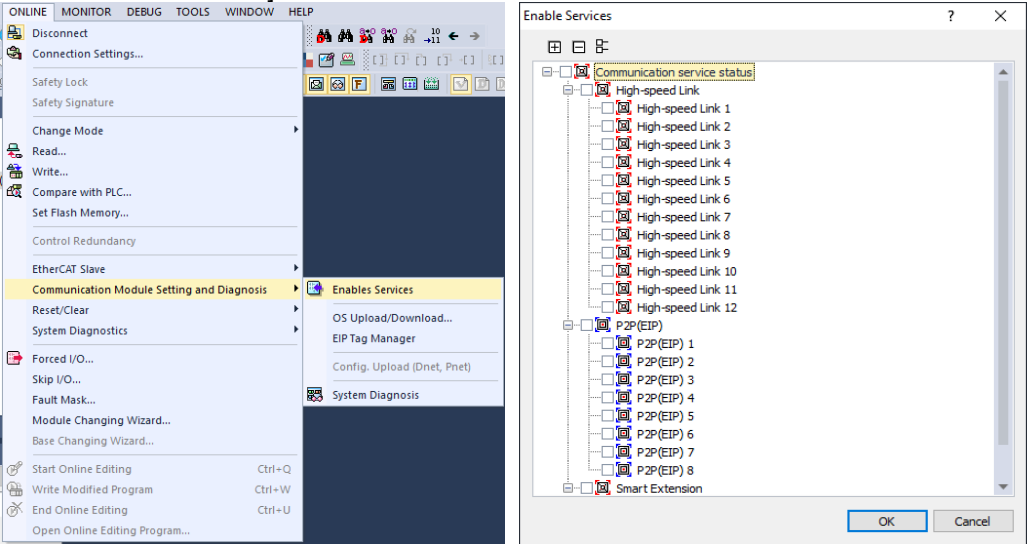
Sequence	Setting process	Setting method
6	Program Download	<p>In the [Online]→[Write] window ,Click ok.</p> 
7	Set link enable	<p>[Online]→[Communication module setting and diagnosis]→check link 1 in [Service Enable].</p> 

## 5.5 HS Link Information

### 5.5.1 High speed link flag

As HS link service exchanges data between two or more communication modules, it is necessary to check the reliability of data read from the other station. User can check the service status by using HS link flag information for reliable communication. In other words, according to the parameters set by the user, the high-speed link flag information is provided by synthesizing the data received up to that point every time a high-speed link is operated. HS link flag information includes run-link (\_HSxRLINK), link-trouble (\_HSxLTRBL) for information of the whole communication network, and \_HSxSTATE, \_HSxTRX, \_HSxMOD, and \_HSxERR for communication status for 128 blocks. When write a program, use high speed link information in the form of keywords and monitor the high speed link status using the high speed link flag information monitor function. It shows the function and definition of HS link information.

Classification	Run-Link	Link-Trouble	Normal communication status	Operation mode	Error operation mode	High-speed link state	Block setting status
Type of information	Complete information	Complete information	Individual information	Individual information	Individual information	Individual information	Individual information
Name of keyword (X: High speed link No = 1~12)	_HSxRLINK	_HSxLTRBL	_HSxTRX[n] (n=0..127)	_HSxMOD[n] (n=0..127)	_HSxERR[n] (n=0..127)	_HSxSTATE [n](n=0..127)	_HSxSETBLOCK[n](n=0..127)
Data type	Bit	Bit	Bit-Array	Bit-Array	Bit-Array	Bit-Array	Bit-Array
Monitoring	Possible	Possible	Possible	Possible	Possible	Possible	Possible
Use of program	Possible	Possible	Possible	Possible	Possible	Possible	Possible

If you select [Variable / Comment] in the project screen of XG5000, [View Flag] screen is displayed. It is displayed when the flag type is "high speed link" in this screen.

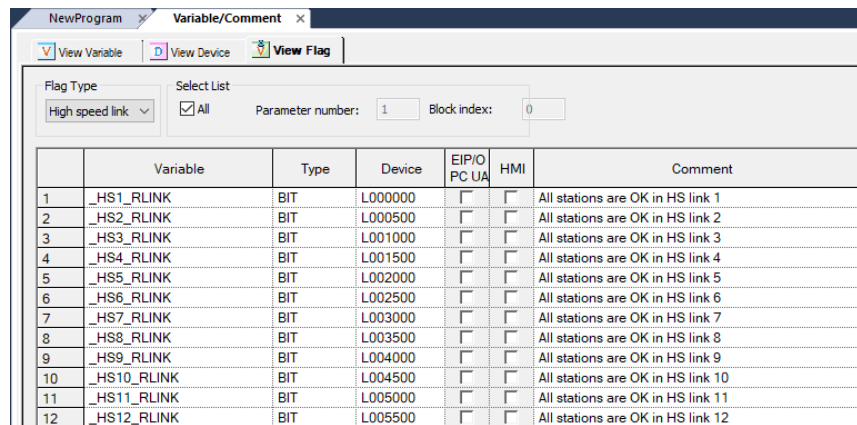

(1) Run-link (\_HSxRLINK, x=High speed link No.(1~12))

This is the entire information that indicates whether the high speed link is normally executed with the set parameters. If it is 'On' once, it is 'On' when the following conditions are met.

- 1) When 'On' is set for Enable Link
- 2) When all parameter registration lists are set normally
- 3) When all the data corresponding to the parameter registration list are transmitted and received to the set cycle
- 4) When the status of all destination stations set for the parameter are in RUN status and there is no error at that time

(2) Link-trouble(\_HSxLTRBL, x=High speed link No.(1~12))

Total Information that indicates whether the High Speed Link is normal with the set parameters. It is Off when Run Link is On and it is on Run Link is Off.

(3) Normal communication status(`_HSxTRX[0..127]`, x=High speed link No.(1~12))

Up to 128 send / receive information as individual information representing the send / receive status of block link parameter. If registered sending / receiving operation is done according to period time, corresponding bit is On and if not, it is Off.

(4) Operation mode(`_HSxMODE[0..127]`, x=High speed link No.(1~12))

This is the individual information that shows the block operation status of HS link parameter and shows 128 operation mode information which is the maximum number of registered. If the station set for the Block item is in Run mode, the relevant bit will become On. If it is in Stop/Pause/Debug mode, the relevant bit will become Off.

(5) Error operation mode(`_HSxERR[0..127]`, x=High speed link No.(1~12))

Individual information indicating the operation status of each high-speed link parameter for each block. Up to 128 blocks of error information are displayed. When the user program cannot be executed, it indicates that the other station PLC is operating normally when it is Off, and when it is On, the other station is in abnormal status.

(6) High-speed link state(`_HSxSTATE[0..127]`, x=High speed link No.(1~12))

As individual information that shows the operation status of each HS block parameter, it displays up to 128 HS link states and displays the information for each item by block. That is, if the sending / receiving status of each list is normal, the operation mode is Run, if there is no error, it is On and if it is not satisfied, the item is Off.

(7) Block setting status(`_HSxSETBLOCK[0..127]`, x=High speed link No.(1~12))

As individual information that shows the operation status of each HS block parameter, it displays up to 128 block setting states and displays the information for each item by block. That is, if the sending / receiving status of each block is normal, the operation mode is Run, if there is no error, it is On and if it is not satisfied, the item is Off.

(8) Receiving area clear setting status when reception timeout occurs (`_HSx_INPUT_CLR`, x=High speed link No.(1~12))

Among the high speed link parameters, it is On when the "Input Data Set in an Emergency: Receive Area Data in Receive Timeout" setting is Latch.

5.5.2 HS Link Information Monitor

High speed link information can be checked by using variable /comment monitor or communication module setting after connecting XG5000 online.

(1) Variable monitor

Variable monitor is a function to monitor only necessary items by using view flag monitor function of XG5000. Select [Variable Monitoring Window] in [View] to display the following variable registration screen. Select the flag to register by selecting the high speed link information flags one by one in the variable flag list list screen. At this time, since \_HSxSTATE [n], \_HSxERR [n], \_HSxMOD [n], and \_HSxTRX [n] are Array type flags, the user must select the array number manually and the array number means the block number in the parameter.

(2) High speed link monitor in XG5000 diagnostic service

Select [Connet] → [Online] → [Communication module setting and Diagnosis] → [System Diagnosis] from XG5000.

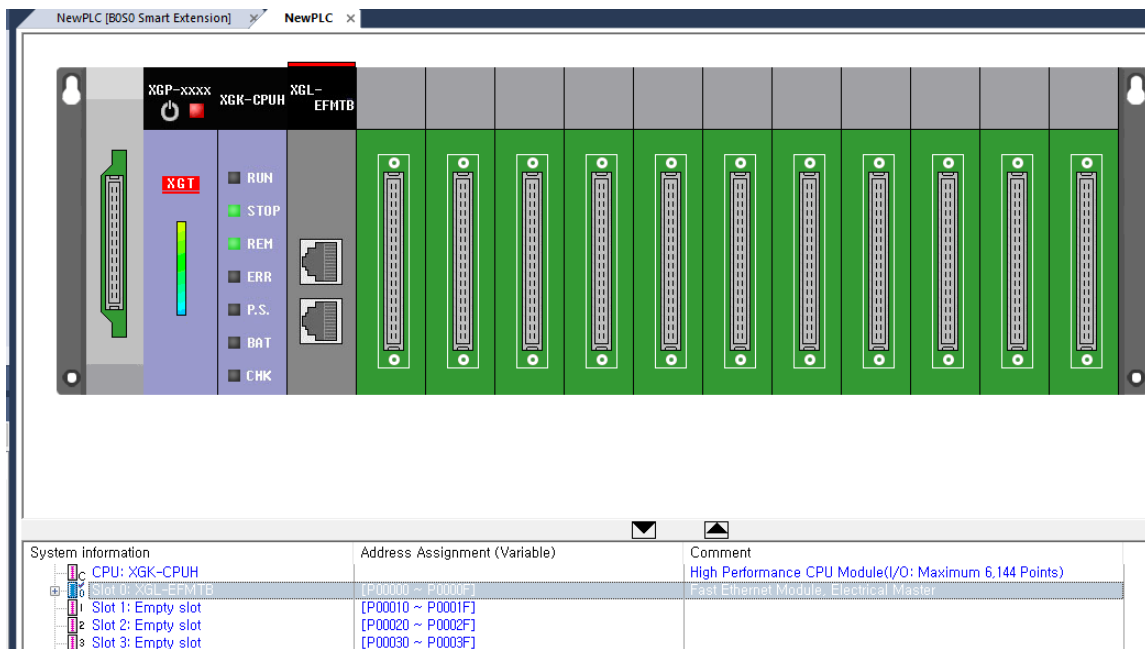

(3) HS Link Service selection

Place the mouse cursor on XGL-EFMTB and right-click and click [Status by Service] to open the following screen. Select HS link service.

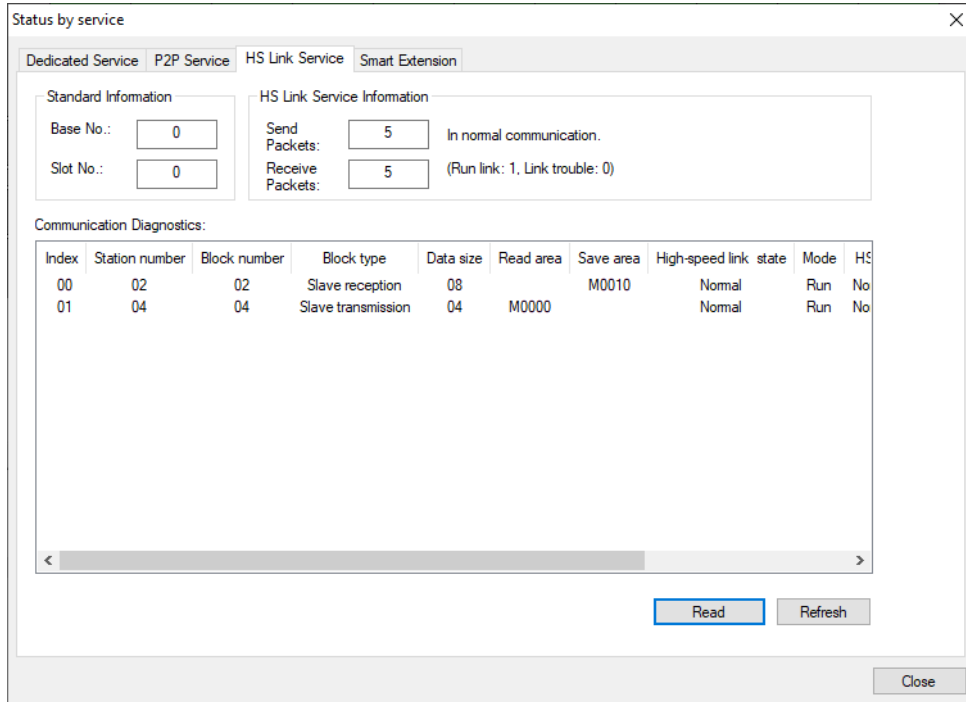

## 5.6 XGR Redundancy Program Method

This section explains how to use High Speed Link in XGR.

### 5.6.1 When configuring an XGR redundant network

When configuring a redundant network in XGR, you can freely set the A-side and B-side station numbers and IP addresses. In other words, The same station number (IP address) or different station number (IP address) can be used. If you use other station number, network operates separately.

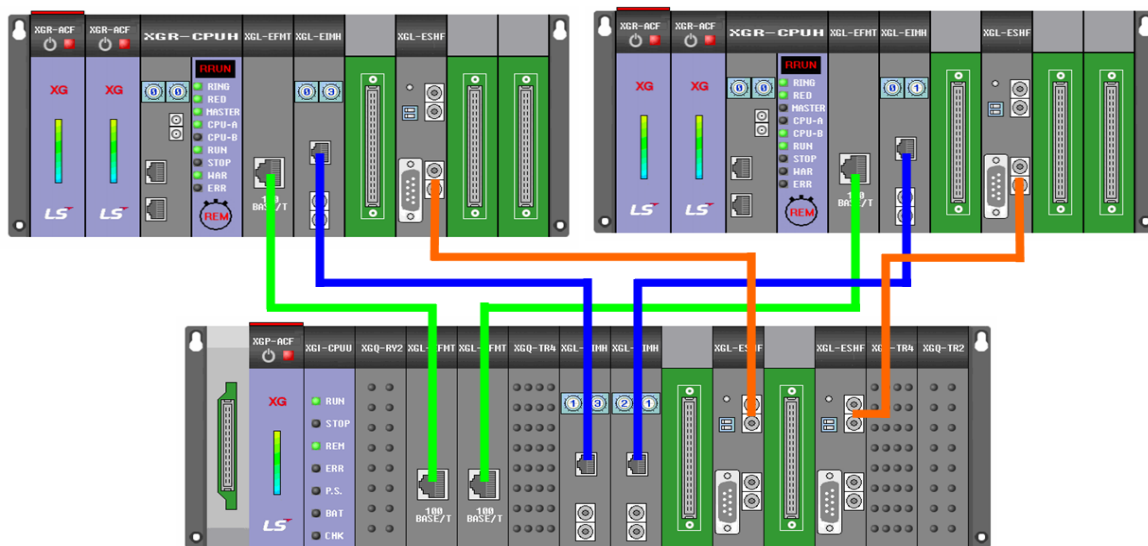

#### (1) When XGR sends - XGK (I) receives

##### 1) Issue of sequence number

When sending from XGR, the highest 1 word must be issued in the ladder program as the sequence number (SEQ\_NO). The sequence number is incremented by 1 for each scan.

##### 2) User data

The data sent by the user is set in the remaining part except the top 1 word. In XGR system, master (communication module of Main base) and standby (communication module of Main base) always provide the same service, so the receiver must decide which data to receive. In addition, if one cable is disconnected due to a network failure, programming is required to receive data from the other side and not receive data from the disconnected side. Based on the issued sequence number, the receiving side can receive and use the updated data whenever the sequence number is updated.

##### 3) Receive side input data setting

When the sequence number is updated as in the case above, the receive-side receives the updated data of A-side or B-side as input data and updates the sequence number at that time. In general, since the standby communication module is serviced 1 scan later than the master communication module, it always receives the communication data sent from the master communication module as input data. Even if data is input from standby after saving the master side sequence number, the data is ignored because it is the same sequence number. In addition, if communication of one side becomes impossible due to network line failure, sequence number is not updated and communication data is not received as input data, thus communication duplication is possible.

### 4) High speed link function block

In XGR and XGI, function block is used for receiving data processing. In XGK, there is no function block, so you can use the program written in the below letter.

#### Notes

Send/ receive using sequence number is a basic data send / receive algorithm method. Depending on your application service, you do not need to use it if you have a specific data pattern.

### (2) When XGK(I) sends - XGR receives

#### 1) Set data send and receive

The XGK (I) side to be transmitted should use two communication modules to service the same data with the same setting. At this time, sequence number is not necessary and the receiving side receives communication data coming into the master as input data. If STATE FLAG is turned off with STATE FLAG as a contact in the condition of receiving input data in consideration of network failure, copy the standby data to the master by SYNC command and receive the data.

#### Notes

Since the block setting is the same for A-side and B-side, if the station number of the sending side is different, the receiving block should be Setting Value to twice the desired block.

5.6.2 When configuring an XGR Single network

In case of a single net in XGR, A-Side and B-Side are grouped in the same network. So, station number and IP should be set differently.

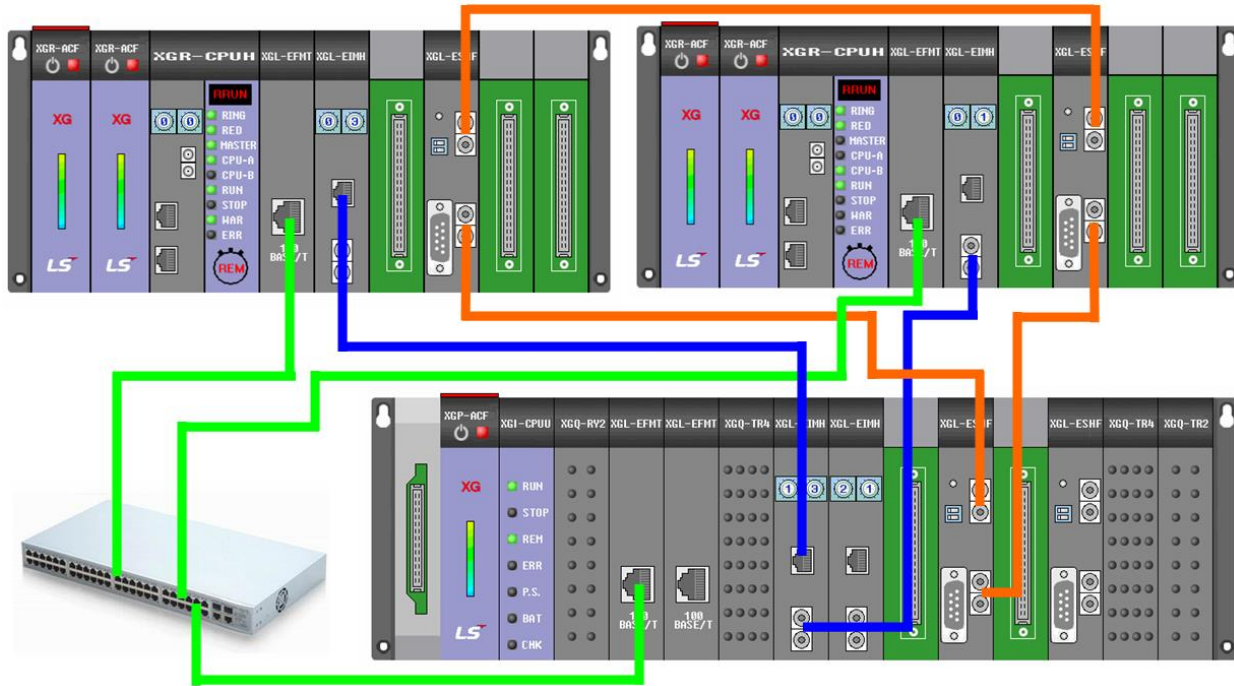

(1) When XGR sends - XGK (I) receives

1) Data send and receive

When sending, block setting is one station number to receive, so communication service is made same as communication setting between XGK (I) and XGK (I). On the receiving side, if the data received from A (B) - Side is the reference or STATE FLAG of the input block of the station is OFF, the data of B (A) -Side station no. must be treated as input data.

(4) When XGK(I) sends - XGR receives

1) Data send and receive

When sending from XGK (I), set data to be sent equally to two communication modules connected to XGR system. In XGR, the receiving side, data coming into the master is treated as input data. If STATE FLAG is set at the contact point of input data and STATE FLAG of the master is turned off, input data of the communication module of the standby main base must be imported to the master using the SYNC command. This series of steps can be set up in the same way as the XGR receiving side when configuring redundant network.

## 5.7 XGR Redundant High Speed Link Setting Program

This section explains how to use High Speed Link in XGR.

### 5.7.1 When configuring an XGR redundant network

(1) When XGR sends - XGK (I) receives

1) Communication settings(XGR send-side)

Standard settings (When using the same high speed link station no. By applying One IP Solution)

High speed link block setting (When the sequence number is set in block 0)

Index	Station type	Mode	Station number	Block number	Module type	Read area	Variable name	Variable name comment	Read area Word size
0	FENet	1. Send	A-side:0, B-side:1	0		%Mw0			1
1	FENet	1. Send	A-side:0, B-side:1	1		%Mw100			2

High speed link block setting (When setting sequence number (first 1 word) and data to be sent by user in block 0)

Index	Station type	Mode	Station number	Block number	Module type	Read area	Variable name	Variable name comment	Read area Word size
0	FENet	1. Send	A-side:0, B-side:1	0		%Mw100			3

2) Ladder program(XGR send- side)

In the HS link block setting, increase the sequence number in the first block and set the send data to be sent by the user in the second block.

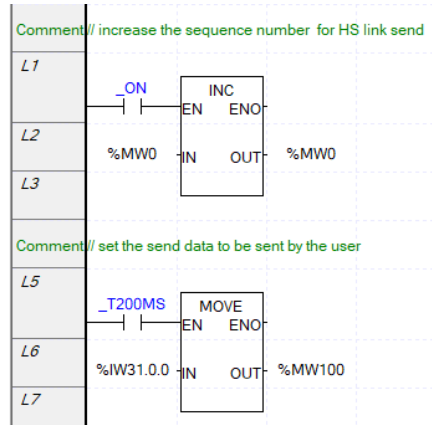

3) Communication settings(XGK(I) receive-side)

Standard settings

## High speed link block setting (Communication module connected to XGR A-Side)

Index	Station type	Mode	Station number	Block number	Module type	Read area	Variable name	Variable name comment	Read area Word size	Save area	Variable name	Variable name comment	Save area Word size
0	FEnet	2.Receive	0	0						%MW10			1
1	FEnet	2.Receive	0	1						%MW100			2

The sequence number and user data can be set in one block as shown below.

Index	Station type	Mode	Station number	Block number	Module type	Read area	Variable name	Variable name comment	Read area Word size	Save area	Variable name	Variable name comment	Save area Word size
0	FEnet	2.Receive	0	0						%MW109			3

## High speed link block setting (Communication module connected to XGR B-Side)

Index	Station type	Mode	Station number	Block number	Module type	Read area	Variable name	Variable name comment	Read area Word size	Save area	Variable name	Variable name comment	Save area Word size
0	FEnet	2.Receive	0	0						%MW20			1
1	FEnet	2.Receive	0	1						%MW120			2

The sequence number and user data can be set in one block as shown below.

Index	Station type	Mode	Station number	Block number	Module type	Read area	Variable name	Variable name comment	Read area Word size	Save area	Variable name	Variable name comment	Save area Word size
0	FEnet	2.Receive	0	0						%MW119			3

### 4) ladder program(XGK(I) receive-side)

Input data setting using HS\_FB function block.

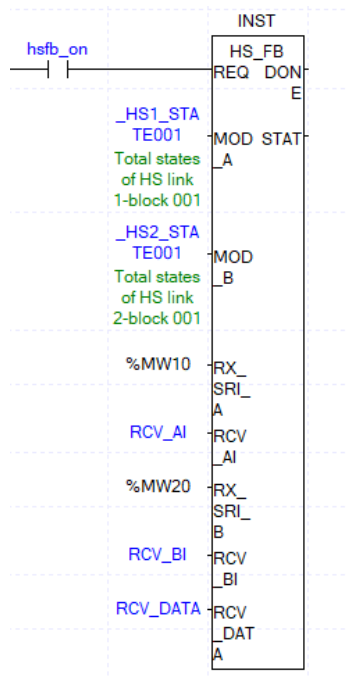

Classification	Contents
MOD_A	STATE FLAG for A-Side High Speed Link Input Block
MOD_B	STATE FLAG for B-Side High Speed Link Input Block
RX_SRI_A	SEQ number of A-Side(Device setting (word) of HS link first input block)
RCV_A1	Receive data of A-Side(Variable Array)
RX_SRI_B	SEQ number of B-Side(Device setting (word) of HS link first input block)
RCV_B1	Receive data of B-Side(Variable Array)
RCV_DATA	Input data to be processed by user by judging SEQ number of A-Side, SEQ number of B-Side and STATE

5) HS link receiving ladder program in XGK

In XGK, there is no function block, so you can use the program written in the below letter. Input the sequence number of A-Side / B-Side input to RX\_SRI\_A / B and the device of data to be input to RCV\_A1 / B1. The MOV instruction has a size of 10 in the bottom item. Consider the size to be entered. For the remaining items, refer to the function block used in XGR (I) of the same title.

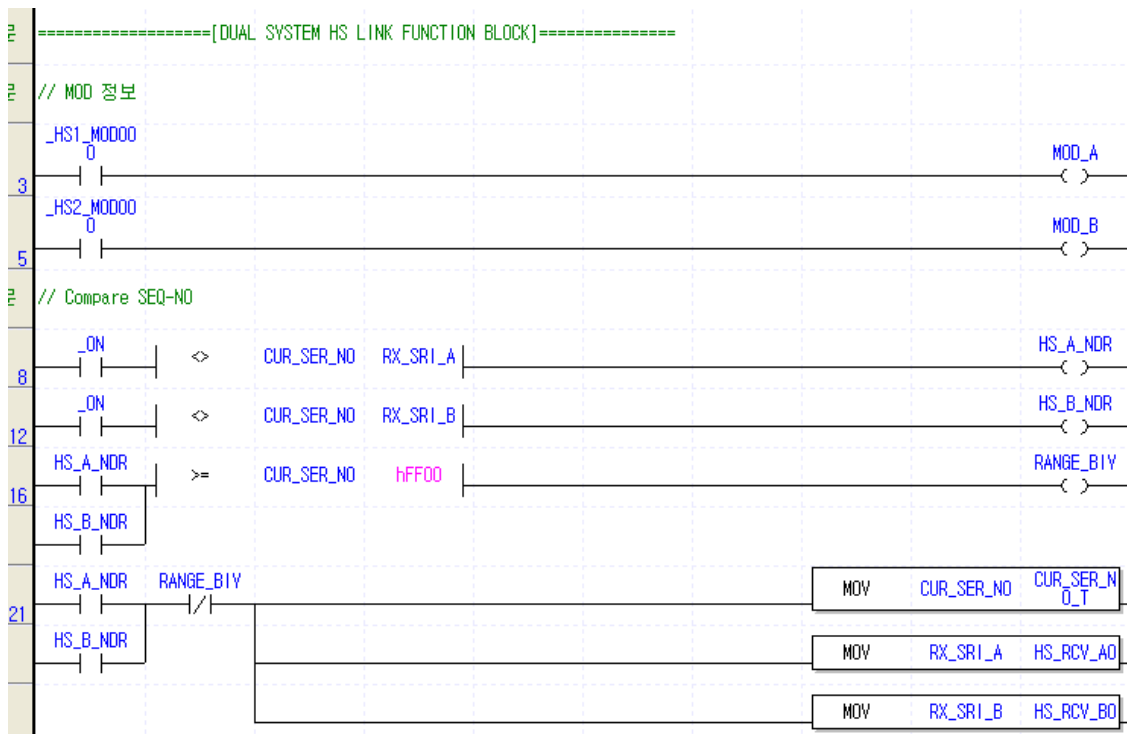

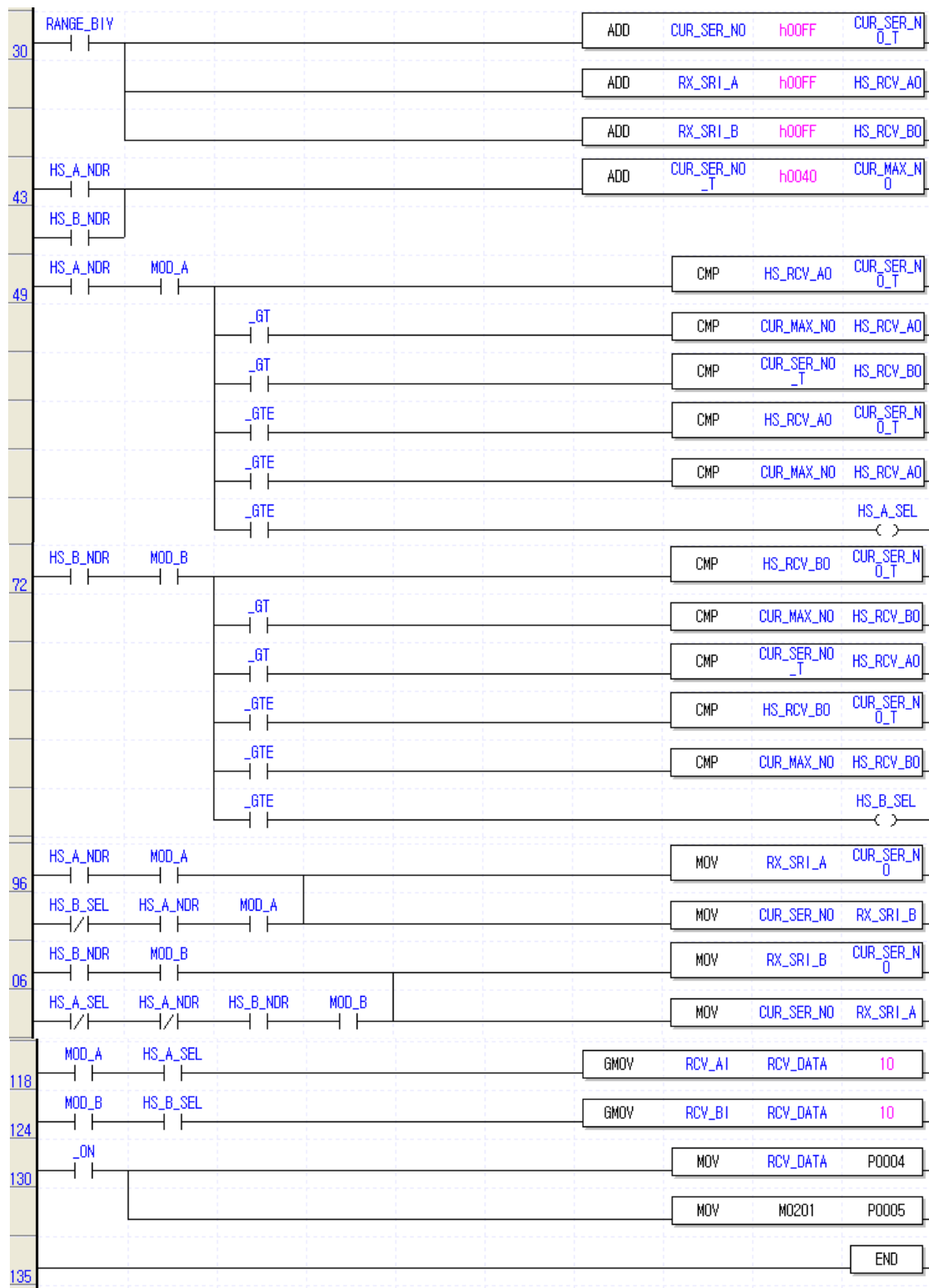

- (2) When XGK(I) sends - XGR receives
  - 1) Communication settings(XGK(I) send- side)

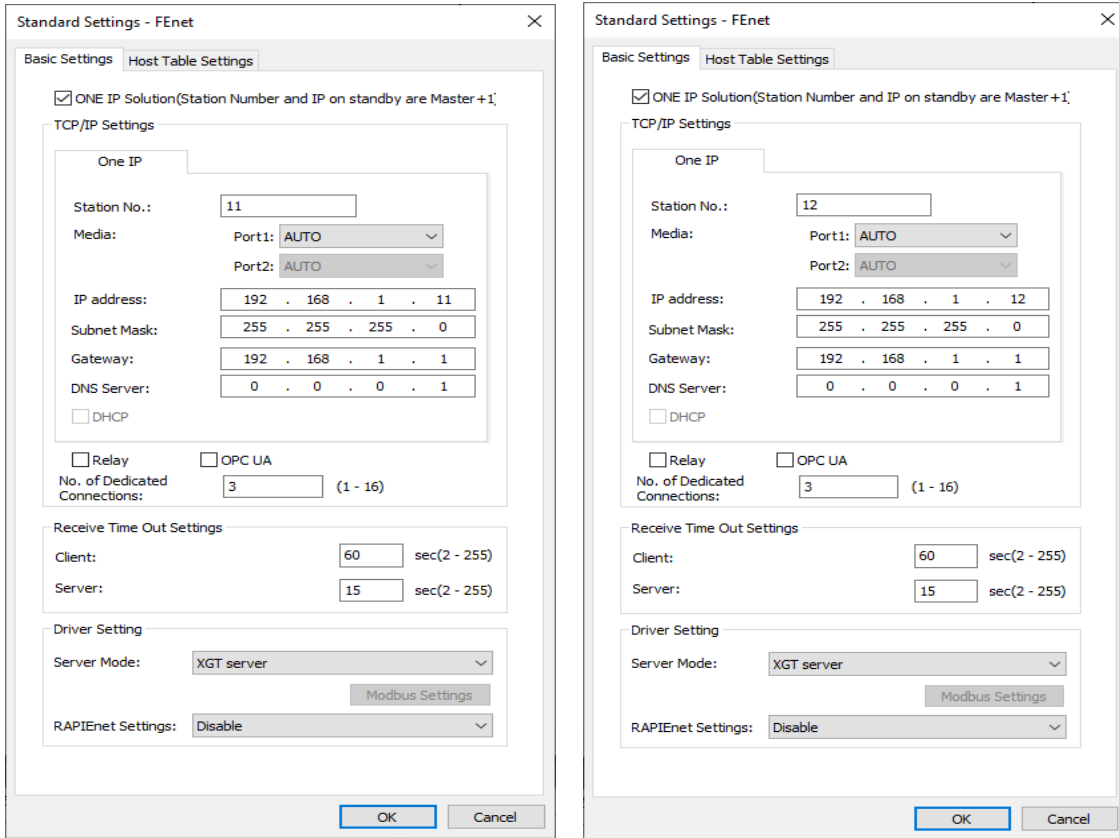

High speed link block setting (Communication module connected to XGR A-Side)

Index	Station type	Mode	Station number	Block number	Module type	Read area	Variable name	Variable name comment	Read area Word size
0	FENet	1. Send	11	0		%MW100			200
1	FENet	1. Send	11	1		%MW500			200

High speed link block setting (Communication module connected to XGR B-Side)

Index	Station type	Mode	Station number	Block number	Module type	Read area	Variable name	Variable name comment	Read area Word size
0	FENet	1. Send	11	0		%MW100			200
1	FENet	1. Send	11	1		%MW500			200

- 2) ladder program(XGK(I) receive-side) : No ladder program required

3) Communication settings(XGR receive- side)

Standard settings

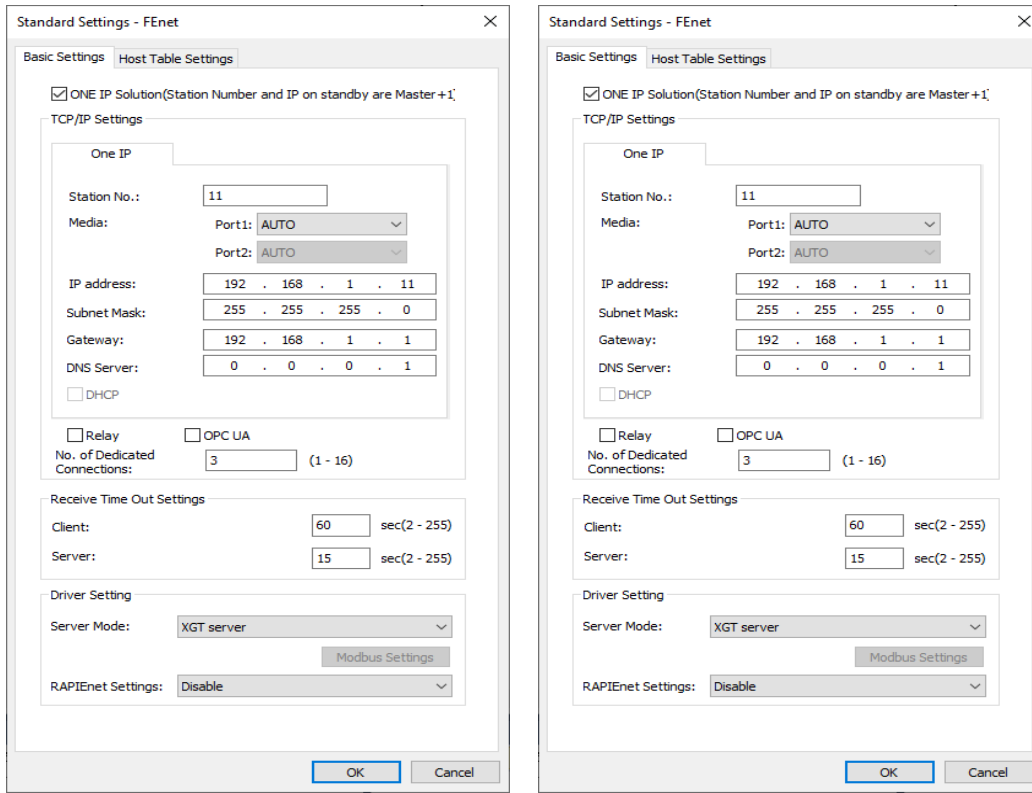

Block setting

Index	Station type	Mode	Station number	Block number	Module type	Read area	Variable name	Variable name comment	Read area Word size	Save area	Variable name	Variable name comment	Save area Word size
0	FENet	2. Receive	11	0						%Mw100			200
1	FENet	2. Receive	11	1						%Mw500			200
2	FENet	2. Receive	12	0						%Mw100			200
3	FENet	2. Receive	12	1						%Mw500			200

4) Ladder program(XGR receive- side)

If the network is normal, you can process data on the master side. However, if a network error occurs, you should copy the data on the standby side to the master and process it as data using the SYNC command using STATE FLAG. At this time, since receiving block of master and standby should be set, use STATE FLAG for each block instead of link trouble (\_HSx\_LTRBL) to determine network failure.

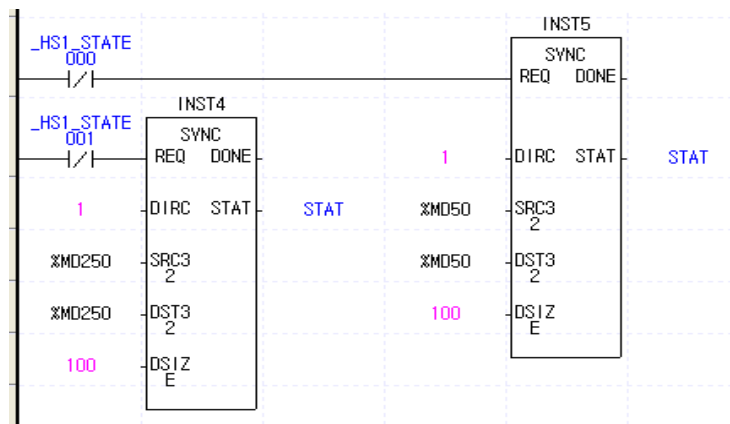

5.7.2 When configuring an XGR Single network

(1) When XGR sends - XGK (I) receives

1) communication setting(XGR send- side)

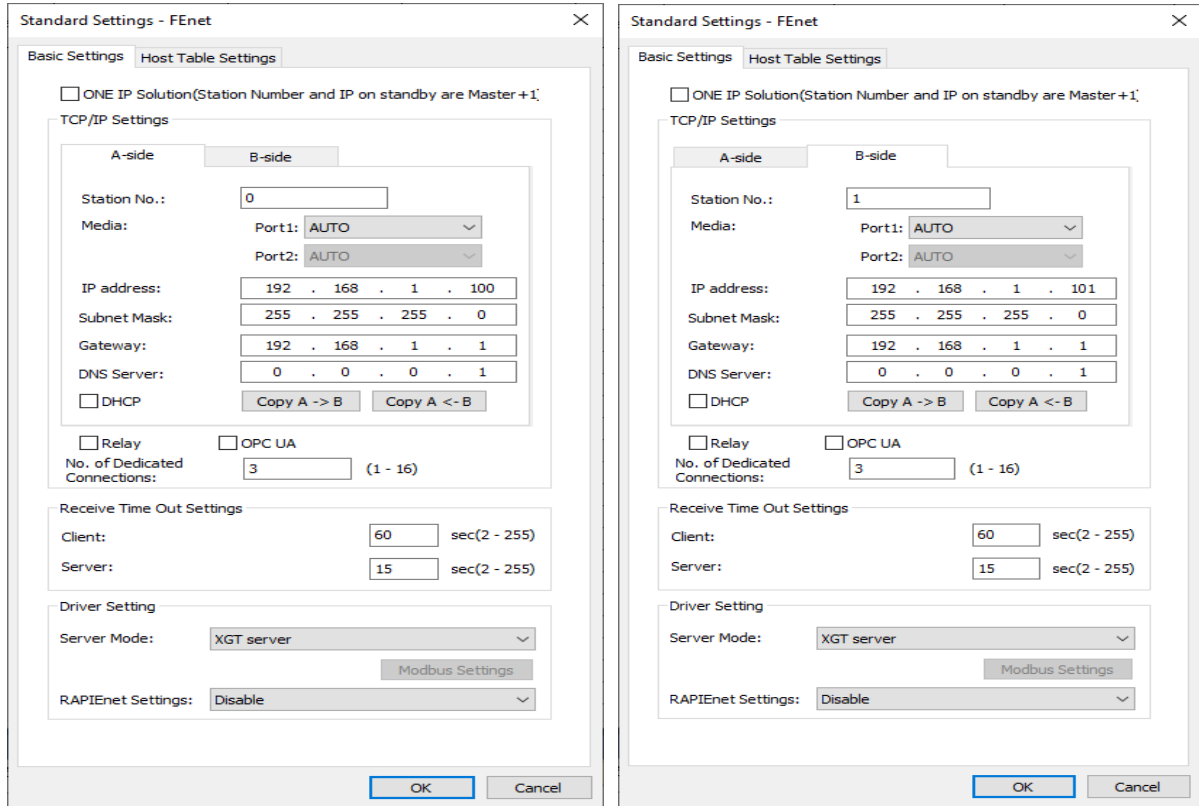

2) High-speed link parameters setting

Index	Station type	Mode	Station number	Block number	Module type	Read area	Variable name	Variable name comment	Read area Word size
0	FEnet	1. Send	A-side:0, B-side:1	0		%MW0			1
1	FEnet	1. Send	A-side:0, B-side:1	1		%MW100			2

3) Ladder program(XGR send- side)

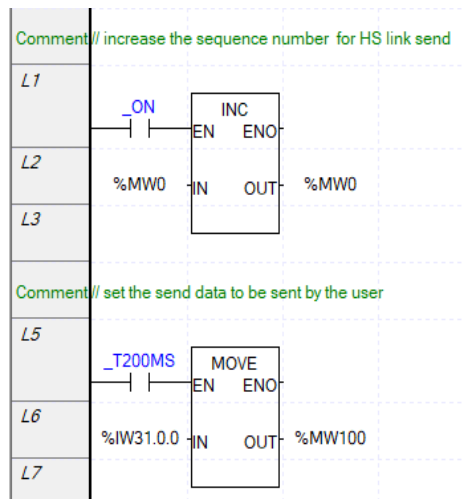

4) Communication settings(XGK(I) receive- side)

High speed link parameter setting at receiving side including sequence number

Index	Station type	Mode	Station number	Block number	Module type	Read area	Variable name	Variable name comment	Read area Word size	Save area	Variable name	Variable name comment	Save area Word size
0	FEnet	2.Receive	0	0						%Mw10			1
1	FEnet	2.Receive	0	1						%Mw100			2
2	FEnet	2.Receive	1	0						%Mw20			1
3	FEnet	2.Receive	1	1						%Mw120			2

5) Ladder program(XGK (I) receive- side)

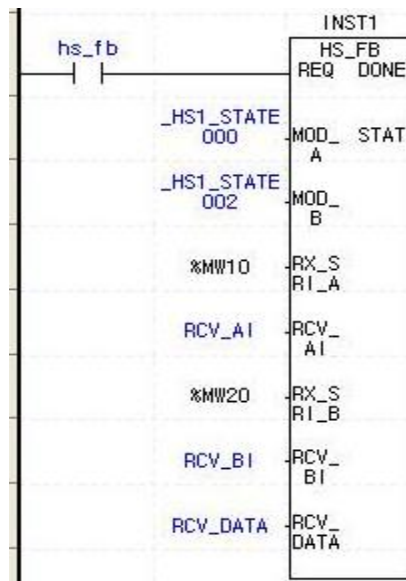

(2) When XGK(I) sends– XGR receives

1) Communication settings(XGK(I) send- side)

High-speed link parameters setting

Index	Station type	Mode	Station number	Block number	Module type	Read area	Variable name	Variable name comment	Read area Word size
0	FEnet	1. Send	11	0		%Mw0			200
1	FEnet	1. Send	11	1		%Mw1000			200

2) ladder program(XGK(I) send- side side) : No ladder program required

3) Communication settings(XGR receive- side)

4) Redundant receive high speed link parameter setting

Index	Station type	Mode	Station number	Block number	Module type	Read area	Variable name	Variable name comment	Read area Word size	Save area	Variable name	Variable name comment	Save area Word size
0	FEnet	2. Receive	11	0						%Mw10			200
1	FEnet	2. Receive	11	1						%Mw1000			200

5) Ladder program(XGR receive- side)

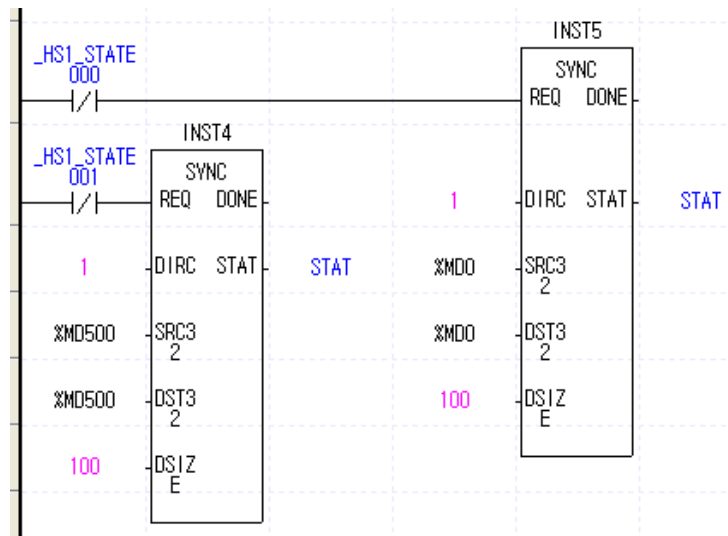

### 5.8 Ethernet System Configuration

Ethernet systems can connect to the Internet public network using the open protocol TCP / IP. Therefore, on-site PLC system access is possible by using GLOFA VIEW (latest: InfoU, XP, iXP) of wide area monitoring system [1,2]. In addition, a local monitoring system directly connected to the site network allows access to on-site PLC systems.

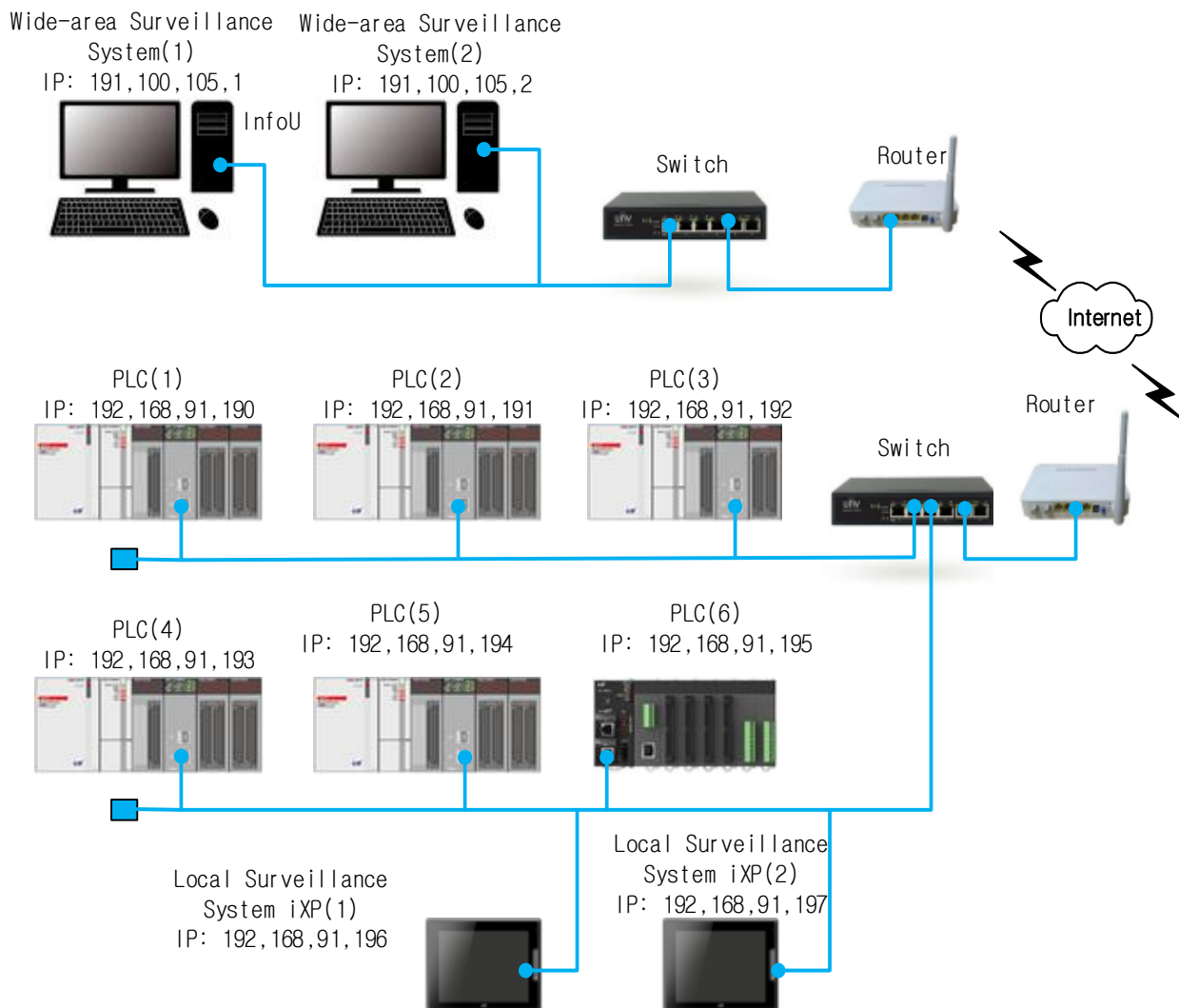

5.8.1 Configuration of Ethernet System Using Dedicated Network

The Ethernet system can be configured using a dedicated network that is not connected to the Internet. Shows an example of an Ethernet system configuration using a dedicated network. PLC system connected to dedicated Ethernet network using XGT Ethernet module can send or receive data using High Speed Link, P2P, dedicated service.

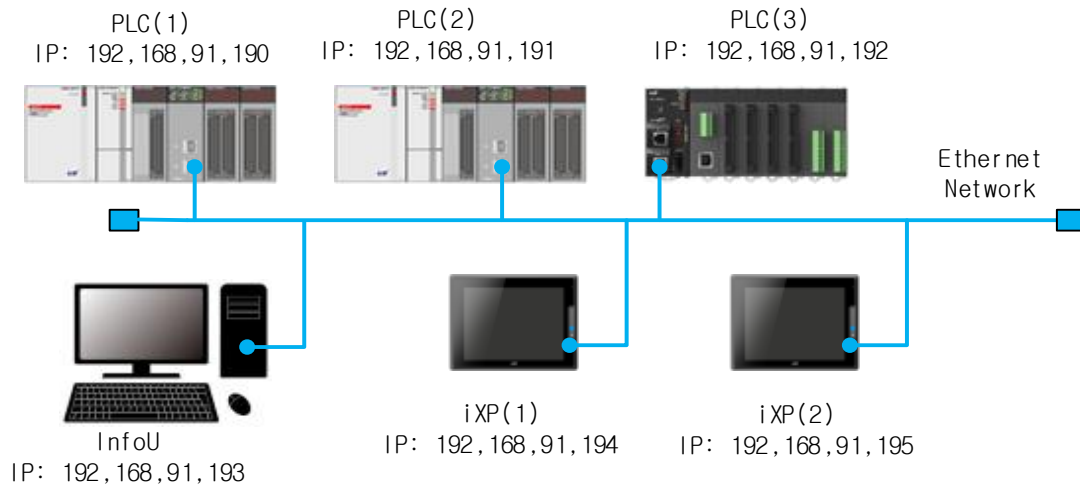

5.8.2 Mix of Dedicated Networks and Third-Party Ethernet Systems

Shows an example where a PLC system and a third-party PLC system are configured using a dedicated network Ethernet system. Our Ethernet module allows for User frame definition Communication. Therefore, knowing the frame structure of other company's PLC Ethernet module, it is possible to send / receive data to / from the company's PLC and other company's PLC by using user defined communication.

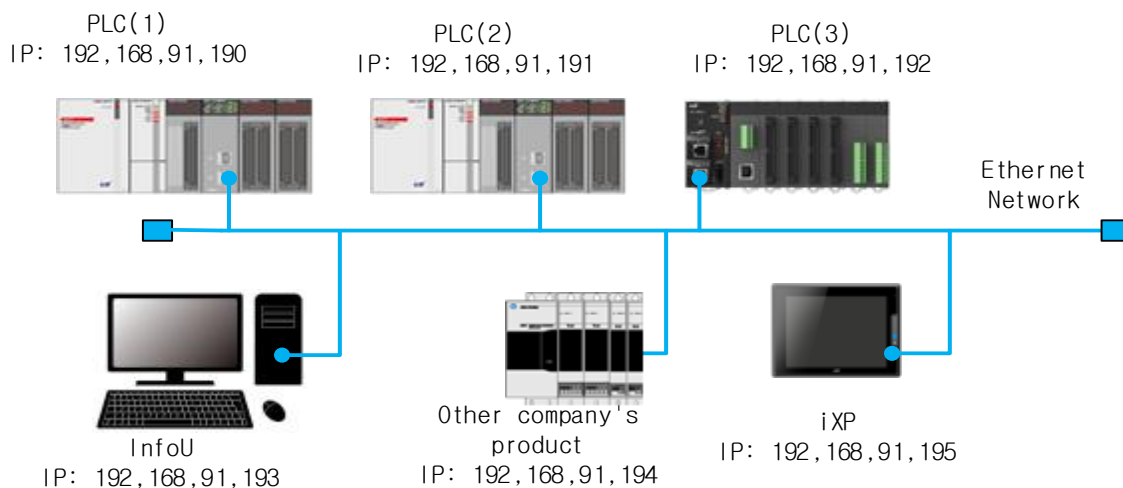

5.8.3 Mix of public, dedicated and third party Ethernet systems

This shows a mixed Ethernet network system in which a PLC system and a third party PLC system are configured as one system using the Internet, that is, a public network and a dedicated network. Wide area monitoring system [1,2] can access remote Ethernet network using public network. The wide area monitoring system [1,2] accessing the remote Ethernet network can access other companies and its own PLC system and send or receive the necessary data. In addition, a local monitoring system directly connected to the site network allows access to on-site PLC systems.

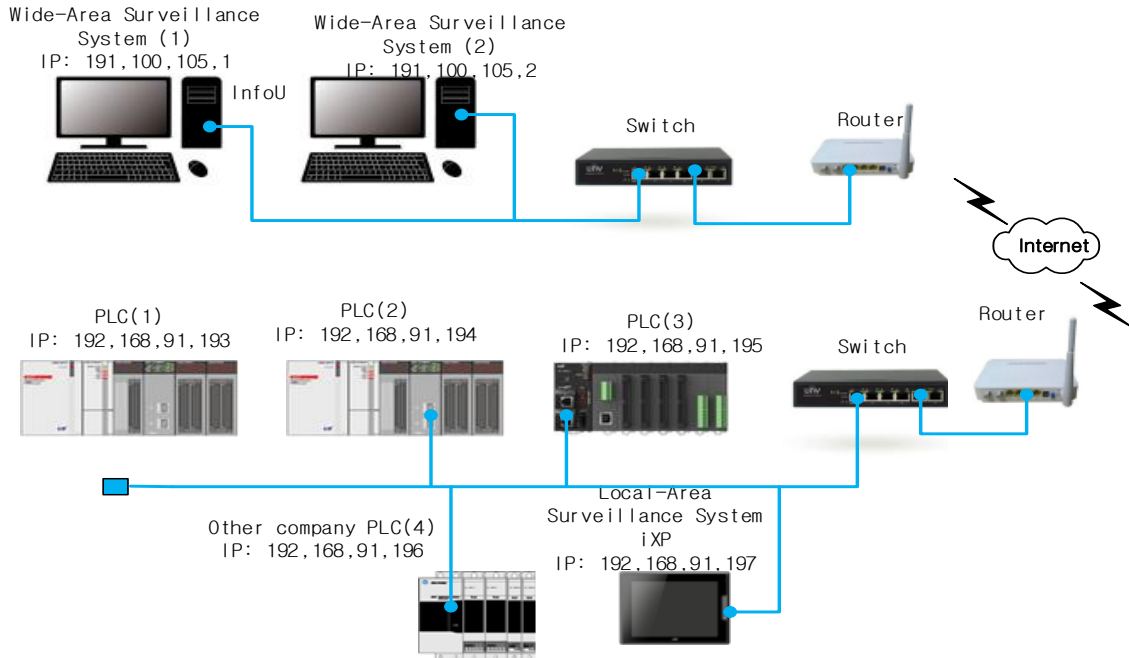

5.8.4 System configuration using InfoU, PLC-to-PLC Dedicated Ethernet in XGR system

In XGR system, the Ethernet module can only be mounted on the main base and must be mounted on the same slot on both bases of A / B. The Ethernet module mounted on the base running as the master CPU performs normal send / receive service, but the Ethernet module mounted on the base running as the standby CPU does not send / receive.

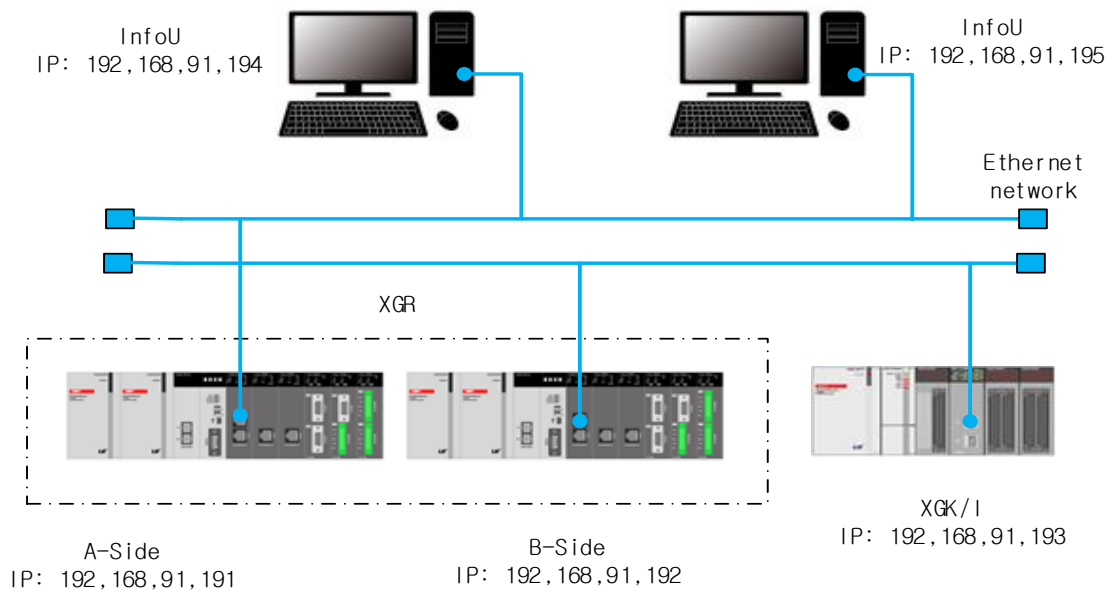

5.8.5 System configuration using single network Ethernet in XGR system

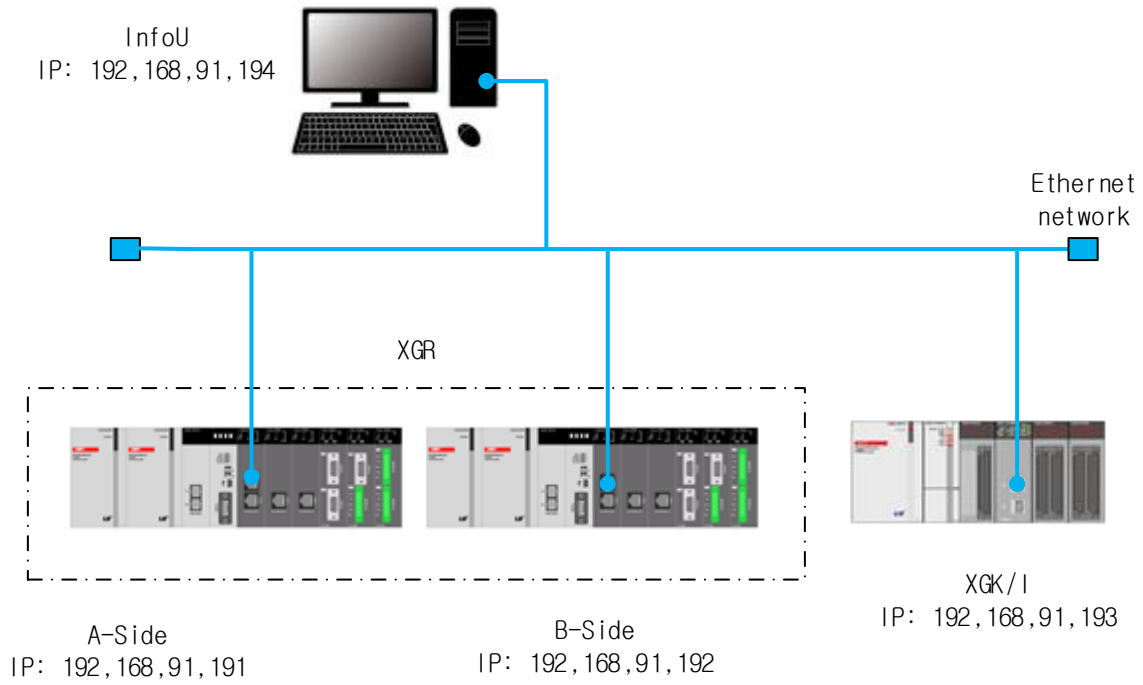

## Chapter 6 P2P service

### 6.1 Overview

#### 6.1.1 Overview of P2P service

P2P service is the master operation of communication module. It is the function implemented by function, block (command) by parameter setting. There are seven P2P commands available in the Ethernet module: Read, Write, Write\_NC, Send, Send\_NC, Receive, and ESend.

For P2P service registration and editing, up to 8 P2P parameters can be set in XG5000. Each P2P parameter consists of up to 64 P2P blocks.

##### (1) P2P parameter registration

- Up to eight P2P parameters can be set per CPU.
- Multiple P2P parameters can be set for the same communication module.  
However, Enable only one of many P2P parameters for the same communication module.
- The each P2P parameter consists of P2P channel, P2P block, user frame definition and email.

##### (2) P2P editing

- Up to 64 P2P blocks that can be registered for each P2P parameter.
- A frame can be registered separately for each driver.

#### 6.1.2 P2P parameter configuration

In order to use P2P service, user carry should set it for desired operation in P2P parameter window. P2P parameter configuration consists of 4 pieces of information.

##### (1) P2P channel

- Set the logical channels (IP, PORT, dedicated driver) of the carry P2P service
- Configurable P2P Driver
  - 1) User frame definition
  - 2) XGT client
  - 3) Modbus TCP client
  - 4) Modbus RTU client( V6.0 or higher)
  - 5) Modbus ASCII client( V6.0 or higher)
  - 6) XGT Cnet client( V6.0 or higher)
  - 7) RAPIEnet client (V6.0 or higher)

##### (2) P2P block

- Set 64 P2P blocks that operate independently

##### (3) User frame definition

- Register of a user frame definition

##### (4) E-mail

Register a frame for transmitting and receiving an- E-mail frame

## 6.2 Type of P2P service

### 6.2.1 Type of P2P command

P2P used by the user for writing a program can be classified into seven commands.

The usage of commands varies according to the service method. Apply each command by referring to the following table.

Classification	Command	Usage
XGT client	Read	Reads the specified area of the destination station
	Write	Sends the area data of its own station to the destination station
	Write_NC	Sends the area data of its own station to the destination station (No confirmation)
User defined frame	Send	Sends the area data of its own station to the destination station
	Send_NC	Sends the area data of its own station to the destination station (No confirmation)
	Receive	Receives and saves data transmitted from the destination station
Modbus client	Read	Reads the specified area of the destination station
	Write	Sends the area data of its own station to the destination station
	Write_NC	Sends the area data of its own station to the destination station (No confirmation)
E-mail	ESend	Transmits a message when an event occurs

#### Notes

1) Difference between Write (Send) and Write\_NC (Send\_NC)

In general P2P communication, request data is sent to the start condition, and after receiving a response, the request data is sent again to the next start condition. If you use Write\_NC (Send\_NC) command, data is sent in the next start condition without receiving a response. Therefore, 3) fast data transmission is possible. Read (Receive) service that requires the other party's response does not provide the corresponding optional function.

※ The transmission data must be set not to exceed 3 KB for the simultaneous start condition.

If more than 3KB of data is used simultaneously, communication module error may occur.

2) In order to use Write\_NC, Send\_NC instruction, XG5000 and CPU O / S as below are required.

Classification	Version
XG5000	V3.61 or higher
XGR CPU	V1.91 or higher

3) Multiple P2P parameters can be set for communication module. However, only one P2P parameter can be enabled.

### 6.2.2 Type of P2P service

(1) XGT Enet client/XGT Cnet client( V6.0 or higher)

The XGT client service is used for data send and receive of the between Ethernet. With the built-in self protocol, the user sets communication by specifying only standard settings such as channel, data type (BIT, BYTE, WORD, etc.) and memory area. Normal Port No. 2004 is used for TCP and Port No. 2005 is used for UDP.

(2) User defined frame

For communication between Ethernet modules or other devices, this service allows users to define third-party protocols in Ethernet modules. Communication protocols for Ethernet-based devices are defined

differently by the manufacturer, which can be edited to suit the characteristics of each communication module. The user frame definition has basic structure of HEAD, BODY and TAIL.

(3) Modbus TCP / Modbus RTU( V6.0 or higher)/Modbus ASCII( V6.0 or higher) Client

Ethernet module supports various Modbus protocol in addition to user frame definition protocol.

(4) RAPIEnet client (V6.0 or higher)

in which If RAPIEnet is set in the standard settings, the RAPIEnet client service is available.

(5) E-mail

E-mail service is a service to notify the remote administrator of the status by using the system when a problem occurs in the system. If the status of the CPU has changed or an event occurred during operation, you can deliver the status information using the mail server.

## 6.3 P2P service setting

### 6.3.1 Ethernet (server) driver

#### (1) Driver setting

Ethernet (server) driver is XGT Ethernet built-in server protocol. The built-in protocol includes the XGT server and the Modbus server. Ethernet (server) driver is used to read or write data of Ethernet module from other station using Modbus or XGT protocol. MMI (HMI) is often used for the correspondent station. Communication with an external device is possible only by setting parameters without the user writing a communication program.

#### (2) Types of Ethernet (server) driver

The types of Ethernet driver that are supported are as follows.

Type	Description	P2P driver
XGT server	XGT dedicated protocol for LS ELECTRIC	XGT client XGT Cnet client
Modbus Server	Modicon's open protocol	Modbus TCP client Modbus RTU client Modbus ASCII client
Smart server	When using XGT dedicated protocol Modbus protocol simultaneously	XGT client XGT Cnet client Modbus TCP client Modbus RTU client Modbus ASCII client
RAPIenet server	RAPIenet protocol of LS ELECTRIC	RAPIenet client

#### Notes

- (1) For 6.0 and below, the number of drivers is reduced by the number of available drivers by the number of Ethernet channels set. Please note when using
- (2) Ethernet (server) driver enables the 1:N communication. Therefore, connected data can be taken to one port set by multiple client devices.
- (3) V6.0 and higher, up to 64 clients can be connected to each server port.

### 6.3.2 P2P channel

The Ethernet P2P channel is used when the XGT FEnet should operate as the master using the built-in protocol or carries out communication using the use defined protocol.

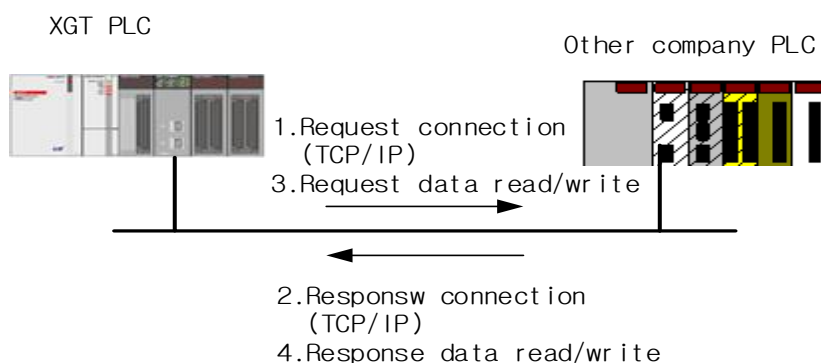

(1) P2P channel setting

The Ethernet module can send and receive data in up to 16 channels. The channel consists of the IP address and port number of the communication device. The number of channels that can be used in the P2P is the total number of channels (16) subtracted by the number of dedicated connections in the basic parameter. The number of P2P channel = 16 - The number of dedicated communication connections) In V6.0 and above, the number of P2P channels of the module is 32 regardless of the number of dedicated connections.

P2P can communicate with simple parameter setting for communication with device using XGT, MODBUS TCP protocol for user's convenience. For communication with other devices, the user can define the frame directly and communicate.

Also, the user can register a message and mail address in order to transmit or receive an email frame. (ASCII support)

However, it is not necessary to set a channel for email communication.

When you select the P2P channel from the P2P Setting window, the P2P Channel Setting window will be displayed as follows.

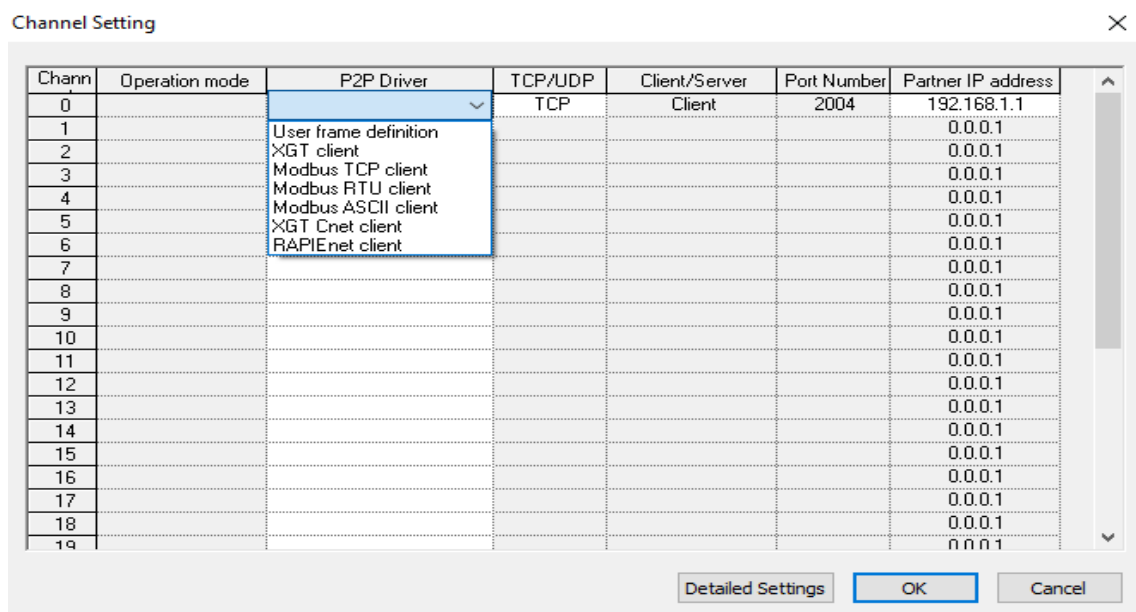

Classification		Content
P2P driver	User frame definition	A protocol used to communicate with an external device. It is a user frame definition protocol (frame definition).
	XGT Enet client	This is the XGT dedicated protocol. (The frame is not defined.)
	XGT Cnet client	It is XGT Cnet client protocol Communicate with LS ELECTRIC Cnet module connected to LTE modem.
	Modbus TCP Client	Defines the operation with the MODBUS TCP protocol of Modicon.
	Modbus ASCII client	Defines the operation with the MODBUS ASCII protocol of Modicon.
	Modbus RTU client	Defines the operation with the MODBUS RTU protocol of Modicon.
	RAPIEnet client	It is RAPIEnet client. However, RAPIEnet must be enabled in Standard settings.
TCP/UDP		Choose between TCP and UDP. When the Modbus TCP is selected, it will be fixed to TCP.
Client/Server		Act as client (master) among client and server.
Port number		Enter the port number of the destination station. Specify a random port for user frame definition.
IP address of destination station		Input IP address of destination station to communicate with XGT Ethernet module module through designated channel.
Details		It is the function to specify the port number of the client

#### Notes

- 1) If XGT Ethernet is client, destination station's IP address must set server device address. If the server is assigned an IP dynamically using DHCP, the IP address will be changed and it will be different from the configured IP. Therefore, communication will not be possible. Therefore, the server must be assigned a fixed IP address and cannot communicate using DHCP.
- 2) The port number can be assigned within the range of 2 bytes. However, note the use of predefined ports. In addition, the port that is used dedicatedly by the Ethernet module cannot be set. XGT Cnet client, RAPIEnet client, Modbus RTU, Modbus ASCII driver are supported in V6.0 or higher.

#### (2) How to use Modbus driver

The table below shows the commands and addresses of Modbus devices.

Code	Function code name	Modicon PLC Data address	Note
01	Read Coil Status	0XXXX (bit-output)	Read bit
02	Read Input Status	1XXXX(bit-input)	Read bit
03	Read Holding Registers	4XXXX (word-output)	Read word
04	Read Input Registers	3XXXX (word-input)	Read word
05	Force Single Coil	0XXXX (bit-output)	Write bit
06	Write output register 1 word (Preset Single Register)	4XXXX (word-output)	Write word
15	Force Multiple Coils	0XXXX (bit-output)	Write bit
16	Preset Multiple Register	4XXXX (word-output)	Write word

6.3.3 P2P block

Select P2P block of the parameter in P2P menu, then P2P parameter setting screen appears.

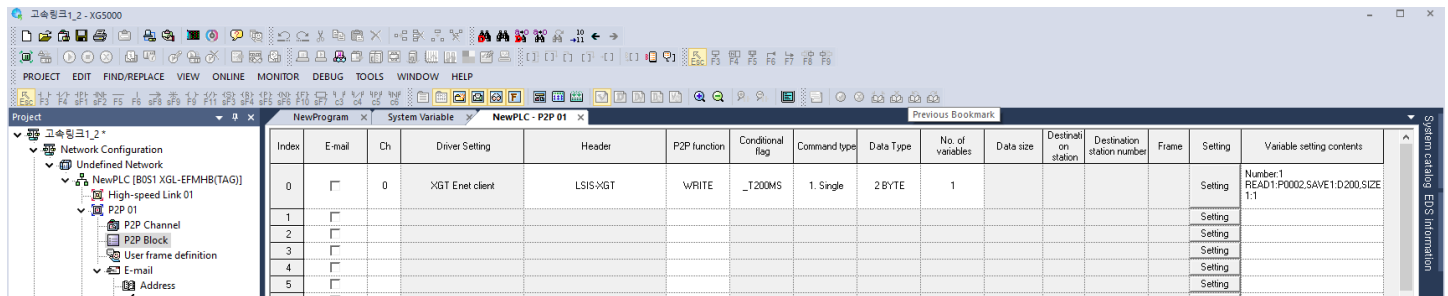

Up to 64 separate blocks can be set. Select any block in XG5000 and set the action of the block as follows.

Index	E-mail	Ch	Driver Setting	Header	P2P function	Conditional flag	Command type	Data Type	No. of variables	Data size	Destination station	Destination station number	Frame	Setting
0	<input type="checkbox"/>	0	XGT Enet client	LSIS-XGT	WRITE	_T200MS	1. Single	2 BYTE	1					Setting
1	<input type="checkbox"/>	1	Modbus TCP client		READ	_T200MS	2. Continuous	BIT	1		<input checked="" type="checkbox"/>	0		Setting
2	<input type="checkbox"/>													Setting
3	<input type="checkbox"/>													Setting
4	<input type="checkbox"/>													Setting

The setting items for each and their meaning are as follows.

Classification	Content
E-mail	Used to set up email service.
Channel	Select the communicate port No. that will be used by the relevant block. The communication port of each block is decided when the parameter is set, and it cannot be changed during Run. The maximum number of channels that can be set is as follows. V6.0 or less: 16 - The number of dedicated communication connections V6.0 or higher : 32
Driver setting	It indicates a communication driver specified in the P2P channel setting. When you specify a channel, the driver will be loaded automatic according to the set channel, and when any channel is deleted in the P2P channel setting, the set driver also will be deleted. See Section 6.3.2 P2P Channel for details.
Header	When setting XGT Enet client driver, you can select either LSIS-XGT or LSIS-GLOFA.
P2P function	This function carries out Read/Write Data from the destination station using the set drivers. The detailed command functions are shown in the table below.
Start condition	It defines the time for the P2P block to operate, and the constant period and memory set trigger condition can be selected.
Command type	Select individual read / write and continuous read / write by determining the detailed operation of read / write. Individual read / write to write / write up to 4 memory areas, and continuous read / write read / write to the size defined at the designated location.
Data type	It defines the data type to be processed by the block, and in case of XGT bit, byte, 2 bytes (word), 4 bytes (double word), 8 bytes (long word) data can be processed.
No. of variables	This item can be defined when Read Individually is selected. The number of areas to be read individually is decided; up to 4 can be selected.
Data size	If you select continuous reading, it defines the size of data to read and its size depends on the data type.
Frame	Select the appropriate frame (group) setting for custom frame communication.
Setting	Designate the area of memory to send / receive. Specify the area to be sent and the area to save the received data of the destination station.

## Command

Please refer to the table below for the usage of commands used when users write programs.

Classification	Command	Usage
XGT/ Modbus client	Read	This command is used to read / save arbitrary area of destination station and it is used the same in XGT / Modbus client driver. Available memory areas: P, M, K, F, T, C, U, Z, L, N, D, R, ZR,% Q,% I,% M, etc.
	Write/Write_NC	This command is used to send the area data of own station to destination station and write data in the desired area of destination station. It is used in the same way in XGT / Modbus client driver. It supports continuous writing and individual writing and can write data in up to four separate areas. Available memory areas: P, M, K, F, T, C, U, Z, L, N, D, R, ZR,% Q,% I,% M, etc.
User frame definition	Send/Send_NC	This command is used to send an arbitrary frame to the external device to be connected by unspecified communication method, not XGT / Modbus client protocol. Only one frame per the Frame Send function should be selected and used, and the memory setting a fixed-sized/variable-sized variable in the relevant frame should be specified in this function. You must define a frame you wish to transmit before using this function.
	Receive	This command is used to receive some frames among the frames sent from the destination station. The same frame cannot be selected for each P2P Frame Receive function block. Receive frame can determine only one receive function block.

6.4 P2P service operation

P2P service operation describes how to read / write data between Ethernet modules as an example.

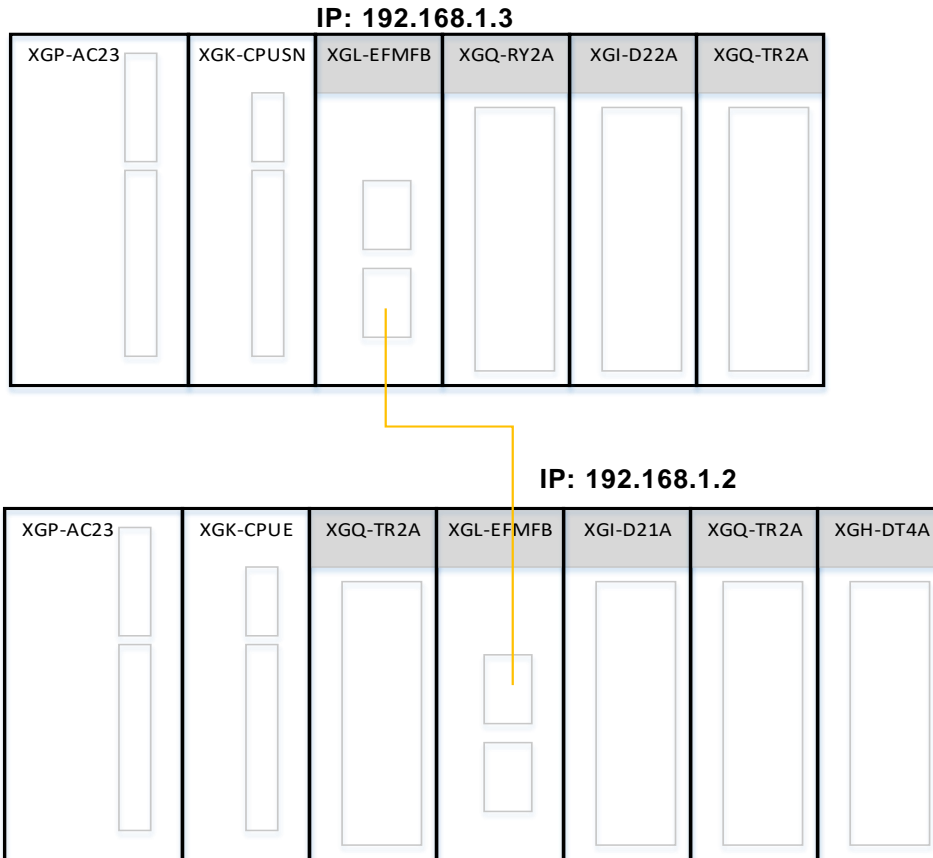

Write / Read data to Ethernet side of IP '192, 168.1.2' to XGT Enet / Modbus TCP client from Ethernet side with IP address 192.168.1.3'. In addition, write word data to Ethernet with IP address '192.168.1.3' to XGT Enet client from Ethernet side with IP address '192.168.1.2'.

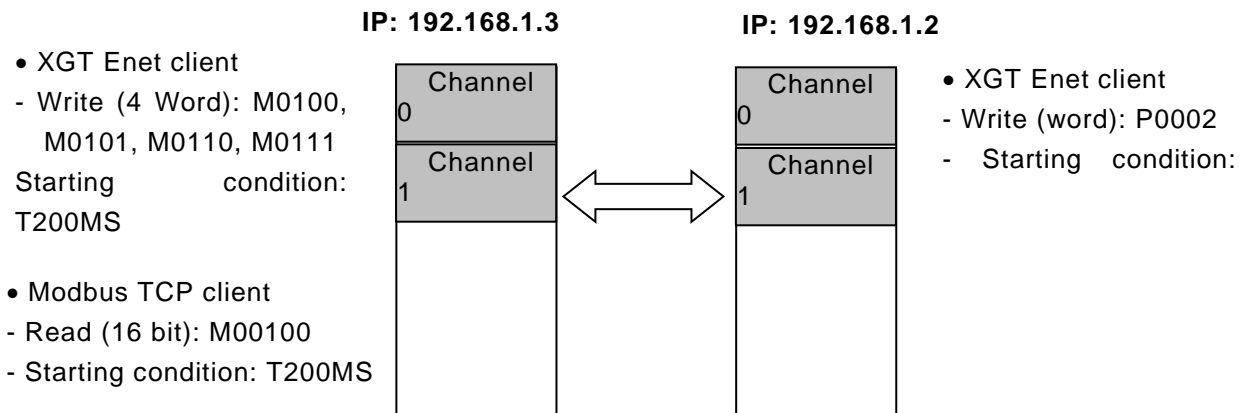

(1) P2P service setting(PLC1)

Program sequence: Connect to PLC system 1, 2 CPU and set in the following order. At this time, PLC1 sets the IP address as "192.168.1.3".

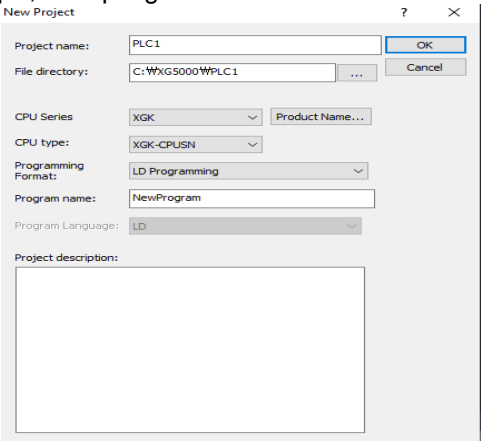
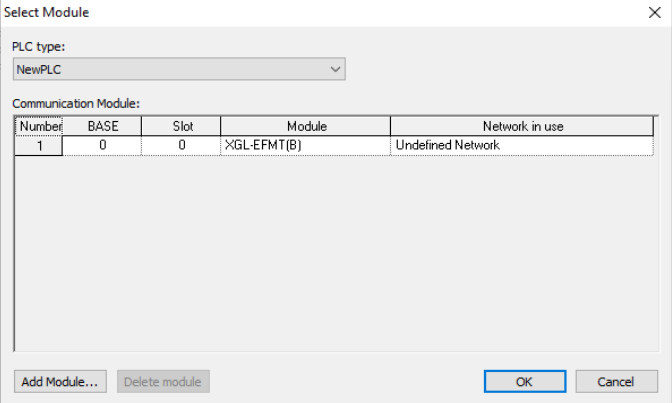
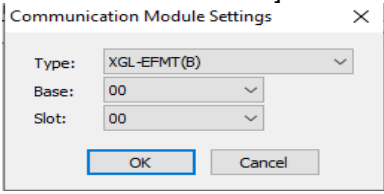
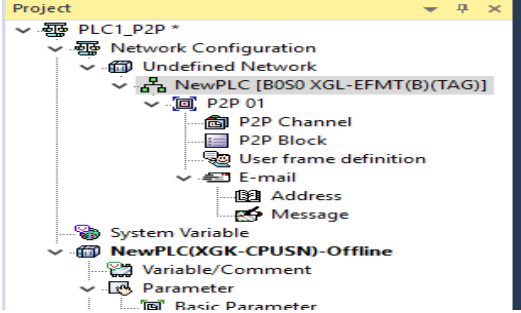
Sequence	Setting process	Setting method
1	Create new project	<p>1) [Project]→Open [New Project] and enter the project name, CPU series, CPU type, programming type, and program name.</p> 
2	Standard network adding	<p>1) Select [Undefined Network]→[Add item]→ [Communication module].                  2) In the [Select Module] window, click "Add module".</p>  <p>1) Set Type, Base and Slot in Communication module settings. After that, select OK button in [Communication module selection] and module setting is completed.</p> 
3	Undefined Network setting	<p>Double-click the communication module in the [Project] window.</p> 

[continue]

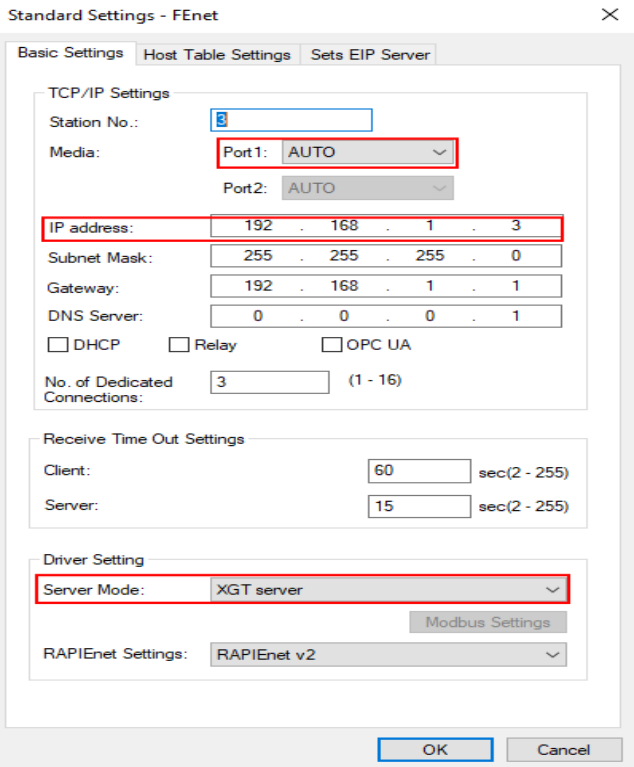
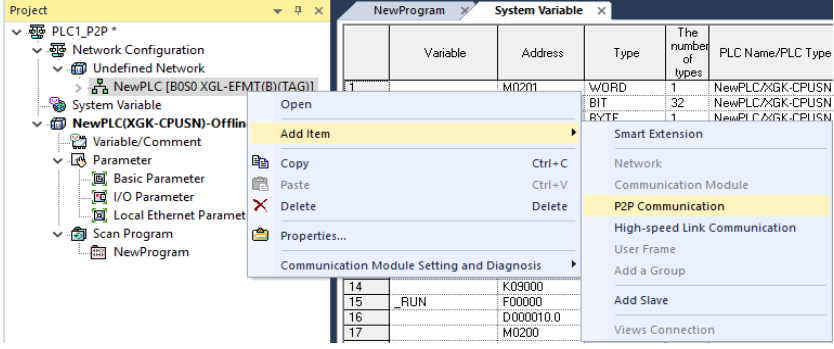
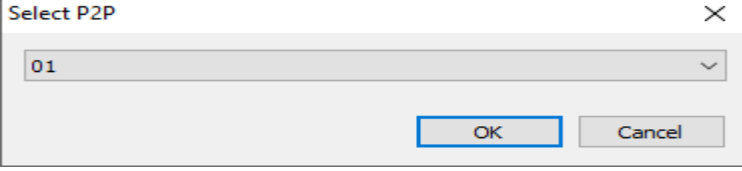
Sequence	Setting process	Setting method
4	Undefined Network setting	<p>1) Set the media, IP address, etc. in the [Standard settings] window.                      Enter own's IP address.                      Select server mode among XGT server / Modbus server / Smart server. If you use XGT server and Modbus server at the same time, select smart server. PLC1 selects XGT server as server operation of XGT Enet client.</p> 
5	P2P parameter setting	<p>1) Select [Ethernet module]→[Add item]→ P2P communication].</p>  <p>2) Select 01 parameter window in P2P selection.</p> 

[continue]

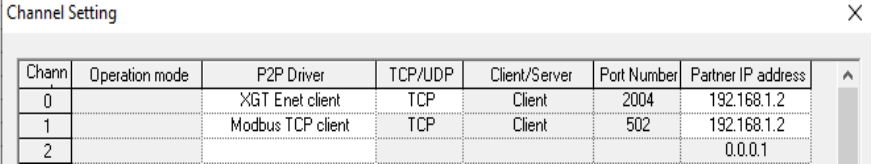
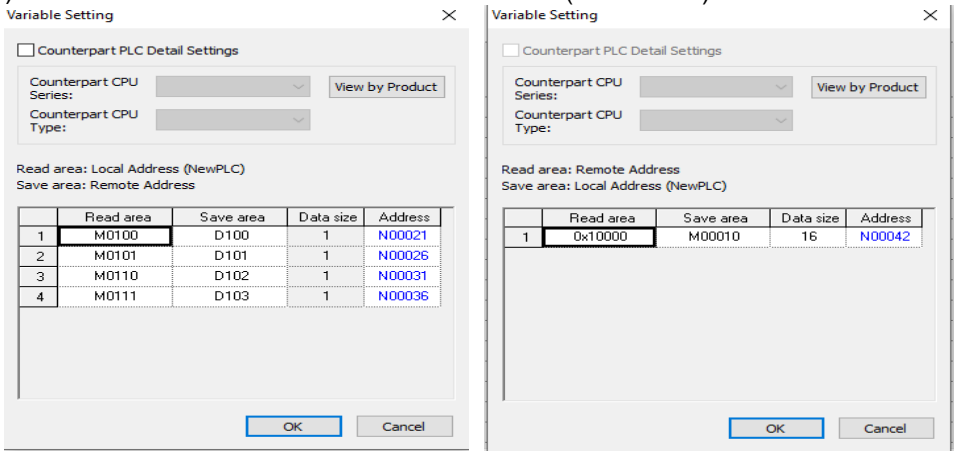
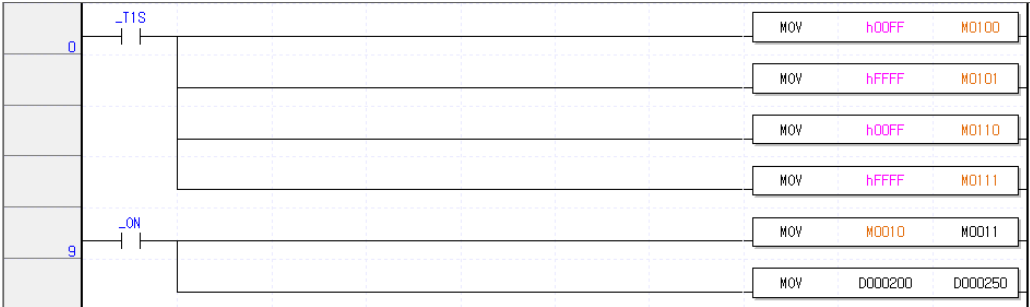
Sequence	Setting process	Setting method																																													
6	P2P parameter setting	<p>1) Click P2P channel item of P2P01 parameter to set channel.                      - Set channel 0 as XGT Enet client and, channel 1 as Modbus TCP client and input the destination station's IP.</p> 																																													
7	P2P parameter setting	<p>1) Set the setting items for each P2P block channel of P2P 01 parameter as follows.                      - Channel 0 writes 4 Word data to the server with XGT Enet client.                      - Channel 1 writes 16 BIT data to the server with Modbus TCP client.</p> <table border="1" data-bbox="508 785 1473 936"> <thead> <tr> <th>Index</th> <th>E-mail</th> <th>Ch</th> <th>Driver Setting</th> <th>Header</th> <th>P2P function</th> <th>Conditional flag</th> <th>Command type</th> <th>Data Type</th> <th>No. of variables</th> <th>Data size</th> <th>Destination station</th> <th>Destination station number</th> <th>Frame</th> <th>Setting</th> </tr> </thead> <tbody> <tr> <td>0</td> <td><input type="checkbox"/></td> <td>0</td> <td>XGT Enet client</td> <td>LSIS:XGT</td> <td>WRITE</td> <td>F00092</td> <td>1. Single</td> <td>2 BYTE</td> <td>4</td> <td></td> <td></td> <td></td> <td></td> <td>Setting</td> </tr> <tr> <td>1</td> <td><input type="checkbox"/></td> <td>1</td> <td>Modbus TCP client</td> <td></td> <td>READ</td> <td>F00092</td> <td>2. Continuous</td> <td>BIT</td> <td>1</td> <td></td> <td><input checked="" type="checkbox"/></td> <td>0</td> <td></td> <td>(Setting)</td> </tr> </tbody> </table> <p>2) Channel 0 writes 4 words from M0100 to server D100.                      3) Channel 1 reads 16 bit data from M00100 (Bit device).</p> 	Index	E-mail	Ch	Driver Setting	Header	P2P function	Conditional flag	Command type	Data Type	No. of variables	Data size	Destination station	Destination station number	Frame	Setting	0	<input type="checkbox"/>	0	XGT Enet client	LSIS:XGT	WRITE	F00092	1. Single	2 BYTE	4					Setting	1	<input type="checkbox"/>	1	Modbus TCP client		READ	F00092	2. Continuous	BIT	1		<input checked="" type="checkbox"/>	0		(Setting)
Index	E-mail	Ch	Driver Setting	Header	P2P function	Conditional flag	Command type	Data Type	No. of variables	Data size	Destination station	Destination station number	Frame	Setting																																	
0	<input type="checkbox"/>	0	XGT Enet client	LSIS:XGT	WRITE	F00092	1. Single	2 BYTE	4					Setting																																	
1	<input type="checkbox"/>	1	Modbus TCP client		READ	F00092	2. Continuous	BIT	1		<input checked="" type="checkbox"/>	0		(Setting)																																	
8	Programming	<p>1) Move the 4 word data to be written to D100 ~ D103 in channel 0 to M0100, M0101, M0110, M0111.                      2) Channel 1 reads 16 bits from the input contact status (0x10000) from the server's input module (PLC2 slot 2) and stores it in the bit address of M00100. In addition, it reads from Word address M0010 and moves to M0011.                      3) Move the value that 1 word data of input module (PLC2 slot 2) is written to D00200 in PLC2 to D00250.</p> 																																													

[continue]

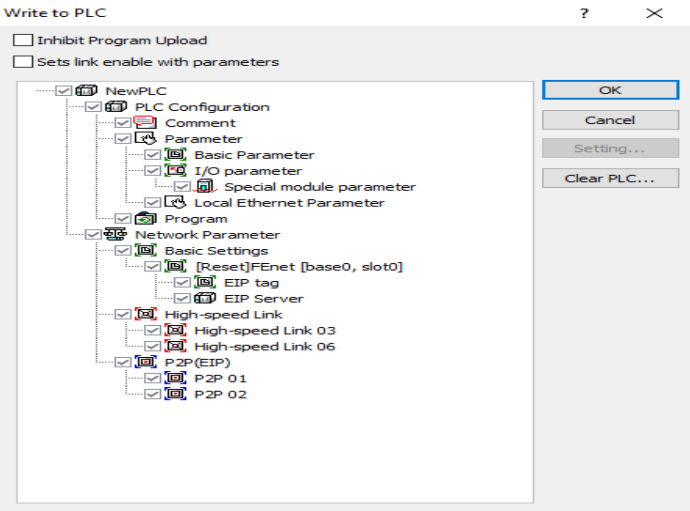
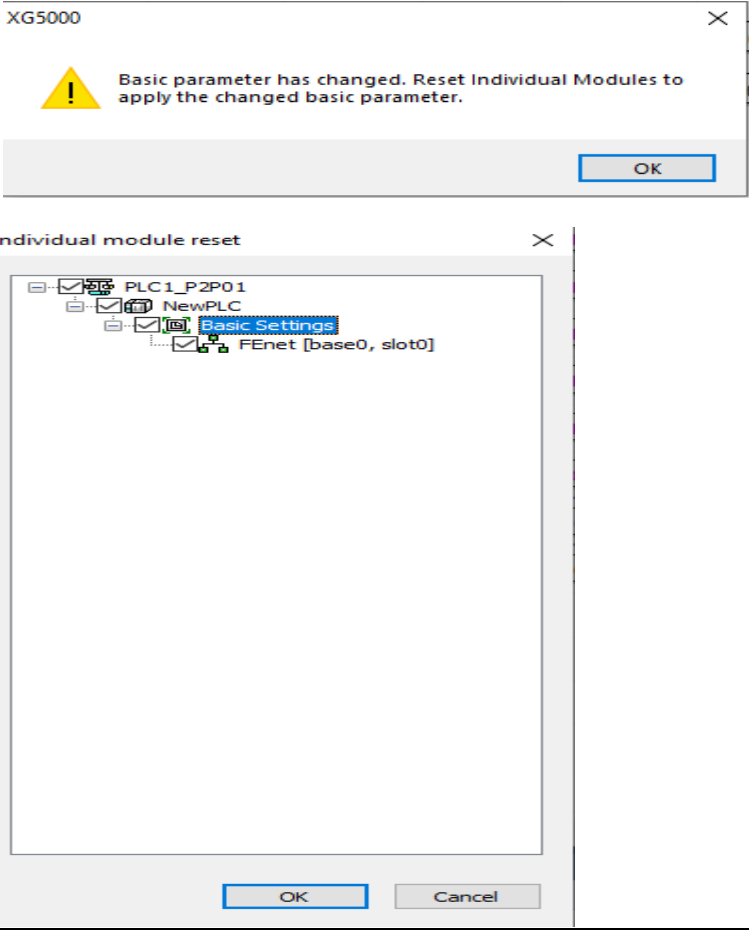
Sequence	Setting process	Setting method
9	Project download	<p>1) After selecting [Online]→[Connect] and [Online]→[Write], download the following items.</p> 
10	Communication module reset	<p>1) Select [On-line]→[Reset/Clear]→ [Reset individual module]                  2) Select the relevant module in the reset window of individual module reset and select OK.</p> 
11	Service enable and run.	<p>Select [Online] →[Communication Module setting]→[Enable Services]. Then select [Online] →[Change Mode]→to run.</p>

(2) P2P service setting(PLC2)

Program sequence: Connect to PLC system 1, 2 CPU and set in the following order. At this time, PLC2 sets the IP address as "192.168.1.2".

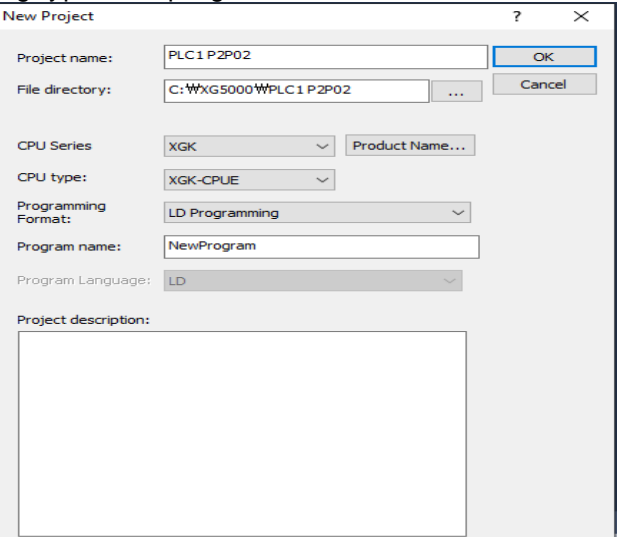
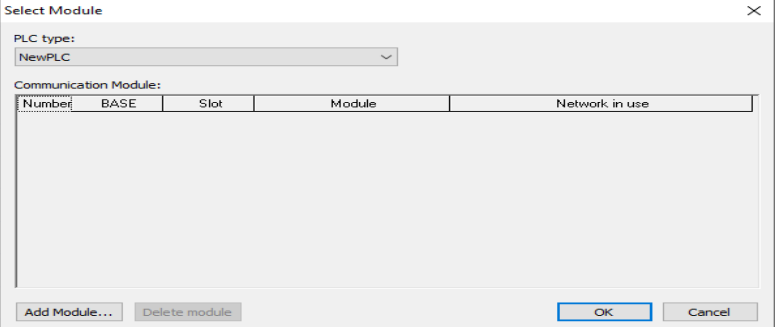
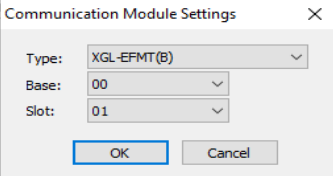
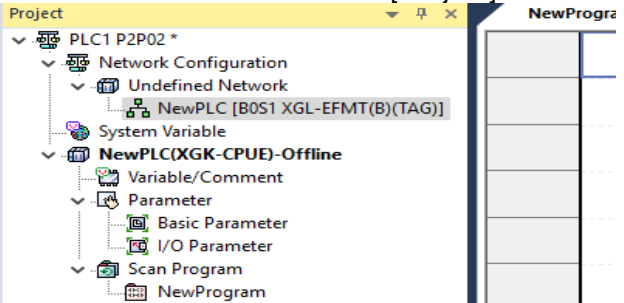
Sequence	Setting process	Setting method
1	Create new project	<p>1) [Project]→Open [New Project] and enter the project name, CPU series, CPU type, programming type, and program name.</p> 
2	Undefined Network Add	<p>1) Select [Undefined Network]→[Add item]→ [Communication module].                  2) In the [Select Module] window, click "Add module".</p>  <p>1) Set Type, Base and Slot in Communication module settings. After that, select OK button in [Communication module selection] and module setting is completed.</p> 
3	Undefined Network setting	<p>Double-click the communication module in the [Project] window.</p> 

[continue]

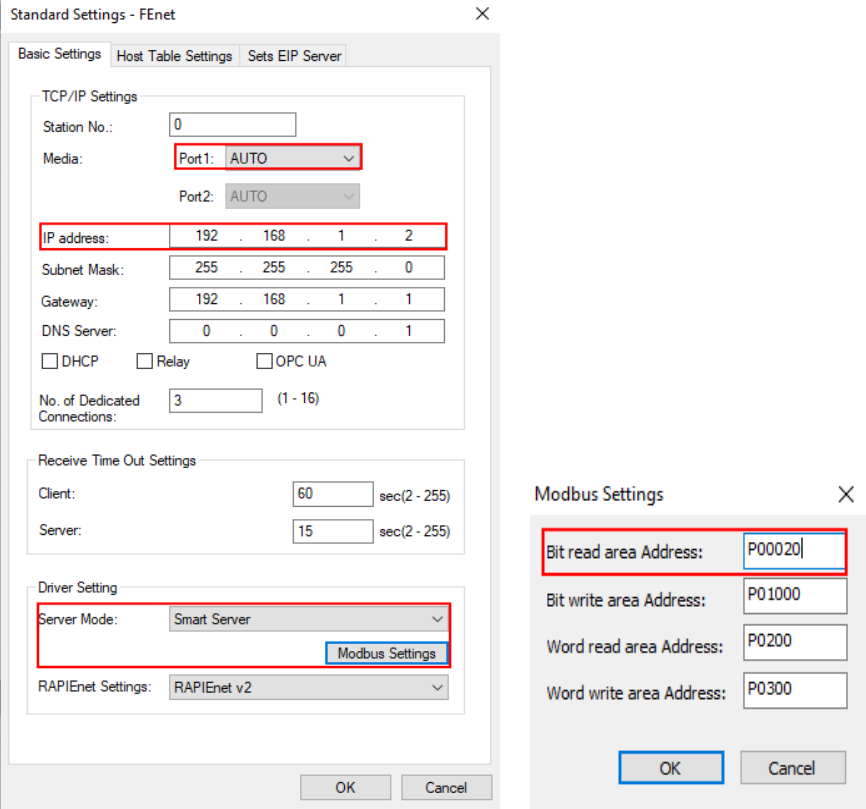
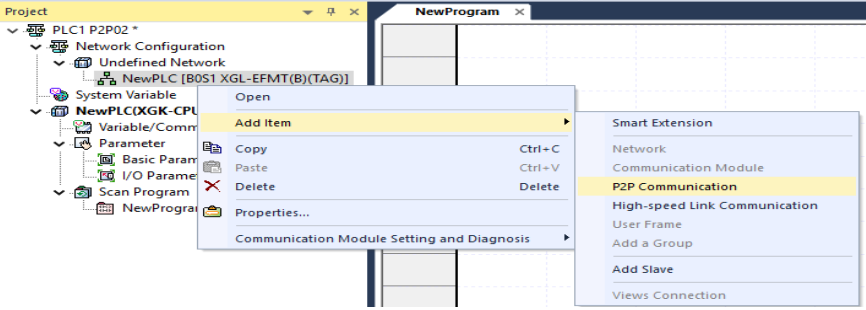
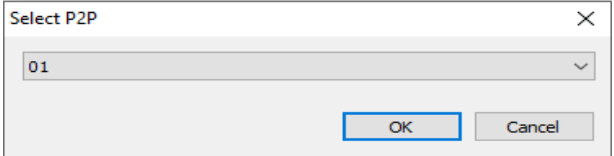
Sequence	Setting process	Setting method
4	Undefined network setting	<p>1) Set the media, IP address, etc. in the [Standard settings] window.                      Enter own's IP address.                      Select server mode among XGT server / Modbus server / Smart server. If you use XGT server and Modbus server at the same time, select smart server. Select Smart Server as the server operation of XGT Enet and Modbus TCP client of PLC1.</p> <p>2) Set the start address of the bit read area of the server side (PLC2) for Bit Read in the Modbus TCP client of PLC1 to P00020.</p> 
5	P2P parameter setting	<p>1) Select [Ethernet module]→[Add item]→ P2P communication].</p>  <p>2) Select 01 parameter window in P2P selection.</p> 

[continue]

Sequence	Setting process	Setting method																																										
6	P2P parameter setting	<p>1) Click P2P channel item of P2P01 parameter to set channel.                      - Set channel 0 as XGT Enet client and input the destination station's IP.</p> <p>Channel Setting</p> <table border="1"> <thead> <tr> <th>Chann</th> <th>Operation mode</th> <th>P2P Driver</th> <th>TCP/UDP</th> <th>Client/Server</th> <th>Port Number</th> <th>Partner IP address</th> </tr> </thead> <tbody> <tr> <td>0</td> <td></td> <td>XGT client</td> <td>TCP</td> <td>Client</td> <td>2004</td> <td>192.168.1.3</td> </tr> <tr> <td>1</td> <td></td> <td></td> <td></td> <td></td> <td></td> <td>0.0.0.1</td> </tr> <tr> <td>2</td> <td></td> <td></td> <td></td> <td></td> <td></td> <td>0.0.0.1</td> </tr> <tr> <td>3</td> <td></td> <td></td> <td></td> <td></td> <td></td> <td>0.0.0.1</td> </tr> <tr> <td>4</td> <td></td> <td></td> <td></td> <td></td> <td></td> <td>0.0.0.1</td> </tr> </tbody> </table>	Chann	Operation mode	P2P Driver	TCP/UDP	Client/Server	Port Number	Partner IP address	0		XGT client	TCP	Client	2004	192.168.1.3	1						0.0.0.1	2						0.0.0.1	3						0.0.0.1	4						0.0.0.1
Chann	Operation mode	P2P Driver	TCP/UDP	Client/Server	Port Number	Partner IP address																																						
0		XGT client	TCP	Client	2004	192.168.1.3																																						
1						0.0.0.1																																						
2						0.0.0.1																																						
3						0.0.0.1																																						
4						0.0.0.1																																						
7	P2P parameter setting	<p>1) Set the setting items for each P2P block channel of P2P 01 parameter as follows.                      - Channel 0 writes 1 word for data to the server (PLC1) with XGT Enet client.</p> <table border="1"> <thead> <tr> <th>Index</th> <th>E-mail</th> <th>Ch</th> <th>Driver Setting</th> <th>Header</th> <th>P2P function</th> <th>Conditional flag</th> <th>Command type</th> <th>Data Type</th> <th>No. of variables</th> <th>Data size</th> <th>Destination station</th> <th>Destination station number</th> <th>Frame</th> <th>Setting</th> <th>Variable setting contents</th> </tr> </thead> <tbody> <tr> <td>0</td> <td></td> <td>0</td> <td>XGT Enet client</td> <td>LSIS&gt;XGT</td> <td>WRITE</td> <td>F00002</td> <td>1 Single</td> <td>2 BYTE</td> <td>1</td> <td></td> <td></td> <td></td> <td></td> <td>Setting</td> <td>Number1 READ1:P0002.SAVE1:D200.SIZ ET.1</td> </tr> </tbody> </table> <p>2) Write 1 word from input module (slot 2, address P0002) to address D200 of server (PLC1).</p> <p>Variable Setting</p> <p><input type="checkbox"/> Counterpart PLC Detail Settings</p> <p>Counterpart CPU Series: <input type="text"/> View by Product</p> <p>Counterpart CPU Type: <input type="text"/></p> <p>Read area: Local Address (NewPLC)          Save area: Remote Address</p> <table border="1"> <thead> <tr> <th></th> <th>Read area</th> <th>Save area</th> <th>Data size</th> <th>Address</th> </tr> </thead> <tbody> <tr> <td>1</td> <td>P0002</td> <td>D200</td> <td>1</td> <td>N00021</td> </tr> </tbody> </table> <p>OK Cancel</p>	Index	E-mail	Ch	Driver Setting	Header	P2P function	Conditional flag	Command type	Data Type	No. of variables	Data size	Destination station	Destination station number	Frame	Setting	Variable setting contents	0		0	XGT Enet client	LSIS>XGT	WRITE	F00002	1 Single	2 BYTE	1					Setting	Number1 READ1:P0002.SAVE1:D200.SIZ ET.1		Read area	Save area	Data size	Address	1	P0002	D200	1	N00021
Index	E-mail	Ch	Driver Setting	Header	P2P function	Conditional flag	Command type	Data Type	No. of variables	Data size	Destination station	Destination station number	Frame	Setting	Variable setting contents																													
0		0	XGT Enet client	LSIS>XGT	WRITE	F00002	1 Single	2 BYTE	1					Setting	Number1 READ1:P0002.SAVE1:D200.SIZ ET.1																													
	Read area	Save area	Data size	Address																																								
1	P0002	D200	1	N00021																																								
8	programming	<p>1) Save data sent from M0100, M0101, M0110, M0111 of PLC1 to D00100 ~ D00103 and move it to D00200 ~ D00203.</p>																																										

[continue]

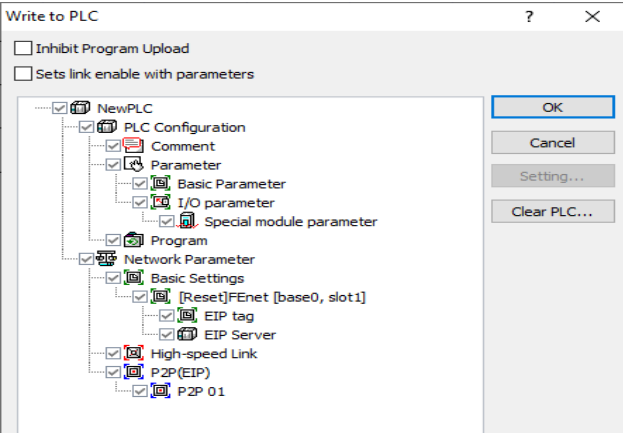
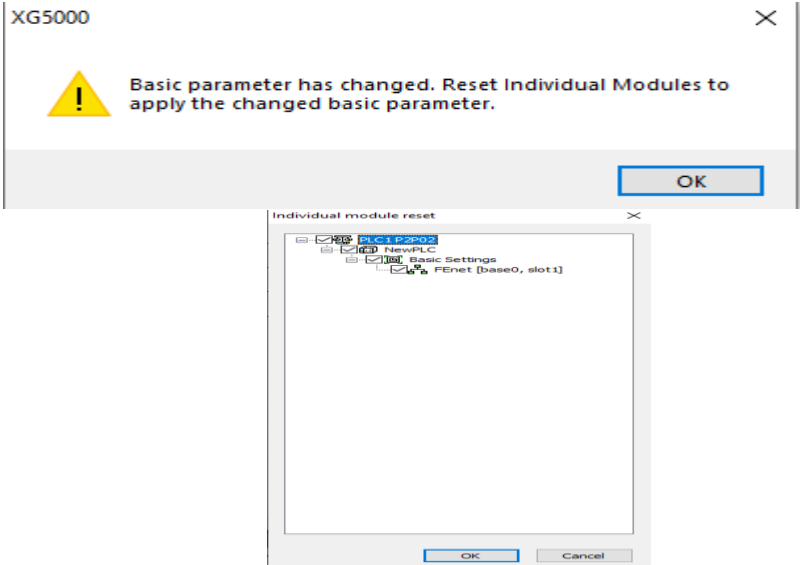
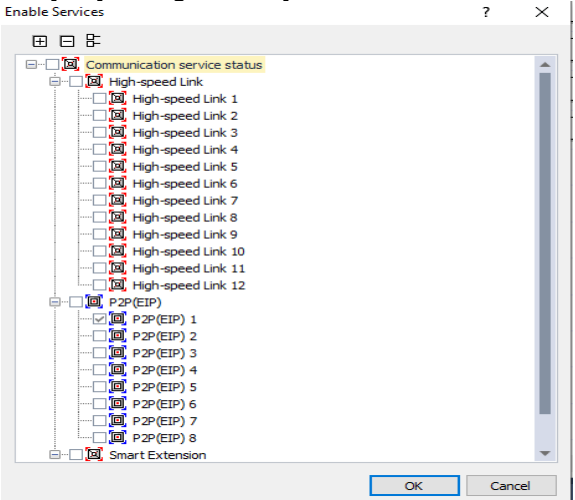
Sequence	Setting process	Setting method
9	Project download	<p>1) After selecting [Online]→[Connect] and [Online]→[Write], download the following items.</p> 
10	Communication module reset	<p>1) Select [On-line]→[Reset/Clear]→ [Reset individual module]                  2) Select the relevant module in the reset window of individual module reset and select OK.</p> 
11	Service enable and run.	<p>Select [Online] →[Communication Module setting]→[Enable Services]. Then select [Online] →[Change Mode].</p> 

## 6.5 User frame definition

### 6.5.1 Overview of a user frame definition

When the user needs to send a frame desired by the user or receives a frame among the frames on the network, the frame to be sent or received should be defined. The user frame definition can be used only in the P2P service. All frames consist of Head, Body and Tail, each of which can be omitted.

The user frame definition is expressed as the group name and the frame name, and the meaning of each item is as follows.

Classification	Usage
Group	It is the group of frames that have the same Header and Tail. Group registration is required for frame registration.
Frame	It consists of Head, Body, Tail. Define the sending and receiving frames. A fixed-sized or a variable-sized variable can be added in Body. The frame is composed of multiple segments and registered in the frame edit window.



Device using protocol not supported by XGT Ethernet module

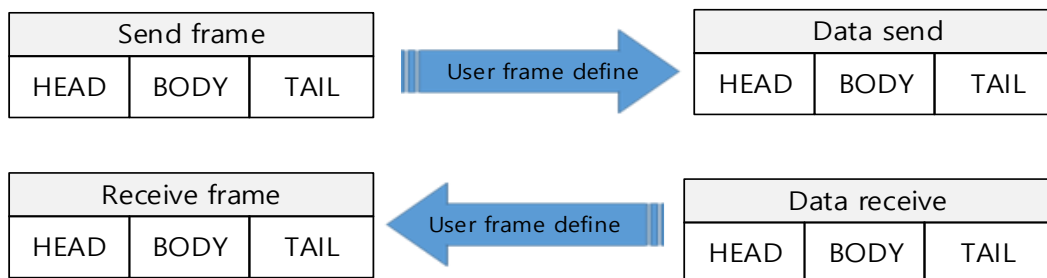

### 6.5.2 User frame definition setting

#### (1) Adds Group

A group is a set of frames. Group registration is required for frame registration.

##### 1) Adding a user frame definition group

Select User frame definition and click the right mouse button as shown. From the Add Group pop-up menu, select [Add Item] → [Add a group].

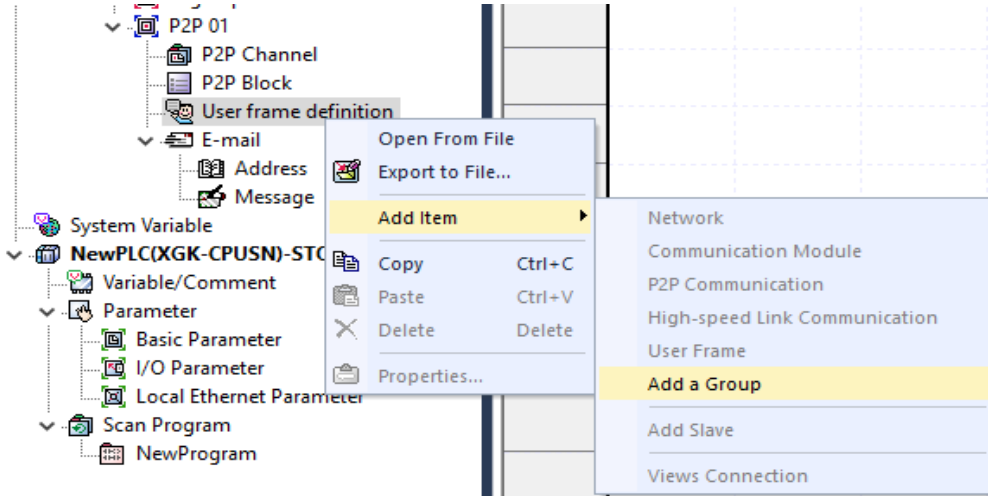

2) Select the name of user frame definition Group name and frame type

In the Edit Group window, enter the group name and select the frame type. Group name can be entered arbitrarily.

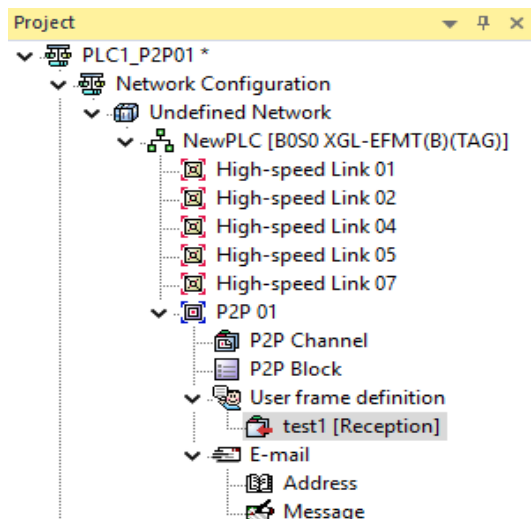

3) When the group name “SEND” and frame type are selected as sending, the results entered in the project window are shown.

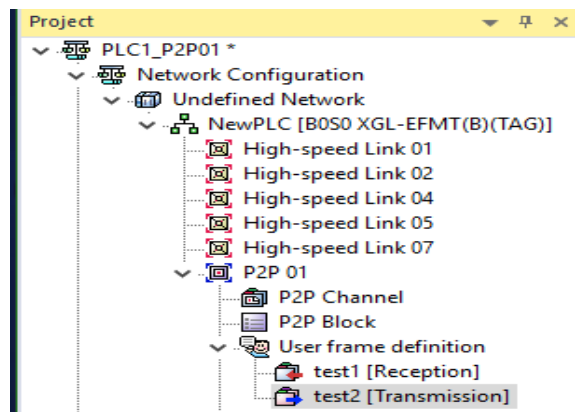

(2) Add frame

If you click the right mouse button on the added d group as below, the pop up menu appears. Click Add frame and select the type of frame you wish to create. When HEAD, TAIL and BODY are selected, the frame is added to the group.

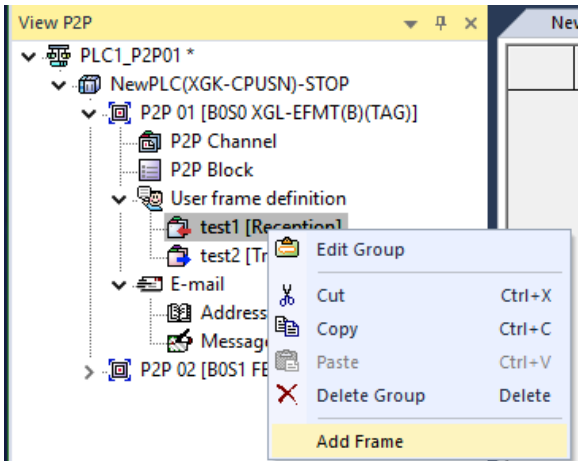

1) Adding HEAD of a user frame definition

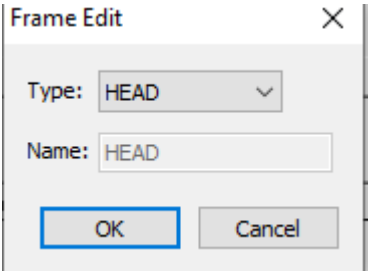

2) Adding TAIL of a user frame definition

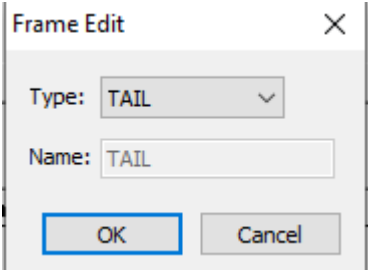

3) Create and add a BODY name of a user frame definition.

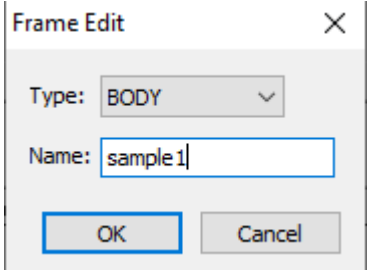

(3) Type of segments

Frame is composed of a number of segments consisting of Head, Body, Tail, and registered in the frame edit window below.

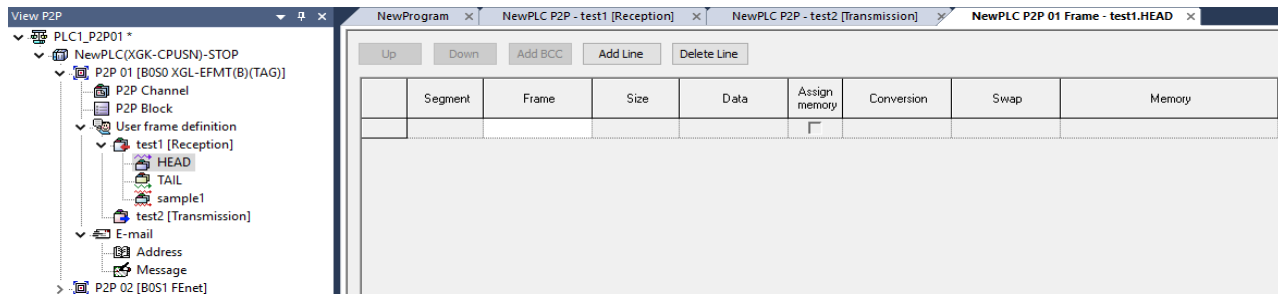

1) Frame configuration

Classification	Command	Usage
Type	Numerical constant	Defines the part of the frame that is fixed as a constant and specifies the data value as Hex.
	String constant	Registers string constant among frames and specifies data as ASCII.
	Fix sized variable	Only available in the body area of the receiving frame. It is used when processing the data (size is Byte unit) of defined frame among received frames. If you check the memory designation, it can be saved in PLC memory. At this time, saved data value can be swapped.
	Variable-sized variable	Only available in the body area. (1) Send frame: When varying the frame length, check the memory designation to configure the send frame with the data read from the PLC memory. (2) Receive frame 1) It is used when processing variable size data among received frames. 2) Registration can be done on only the last segment among the areas of Body frame. Selecting memory designation saves the data of the corresponding segment among the received frames in the memory area. The data is also swappable.
	Size	The data size is displayed in bytes.
	Data	Input data to send and receive.
	Assign memory	Specify the memory area to save and read the data sent and received.
Conversion	Hex To ASCII	Send: Converts data read from the PLC memory into ASCII and configures a frame to be transmitted. Receive: Saves received data after converting it into ASCII. When using 2 words of PLC memory MW100 to convert the frame to Hex to ASCII, when h34353637 is stored in MW100, the corresponding segment of the transmission frame becomes "4567". And if you save a part received frames after converting it into Hex and the value of the relevant area is "4567", h34353637 will be saved to the PLC memory
	ASCII To Hex	Send: Converts data read from the PLC memory into Hex and configures a frame to be transmitted. Receive: Saves received data after converting it into Hex.

Swap	Swap data in 2,4,8 byte unit. The result of swapping h1234567811223344 according to each method is as follows. -2 Bytes Swap: h3412785622114433 -4 Bytes Swap: h7856341244332211 -8 Bytes Swap: h4433221178563412
------	---

2) The specification of transmission and reception frame supported in the user frame definition communication is as follows.

Group	Frame	Segment	Contents
Send frame	HEAD	Numerical constant	Up to 10 bytes
		String constant	Up to 10 bytes
	TAIL	Numerical constant	Up to 10 bytes
		String constant	Up to 10 bytes
		BCC	Only one BCC can be applied.
	BODY	Numerical constant	Up to 10 bytes
		String constant	Up to 10 bytes
		Variable-sized variable	Up to 4 variables are available.
Receive frame	HEAD	Numerical constant	Up to 10 bytes
		String constant	Up to 10 bytes
	TAIL	Numerical constant	Up to 10 bytes
		String constant	Up to 10 bytes
		BCC	Only one BCC can be applied.
	BODY	Numerical constant	Up to 10 bytes
		String constant	Up to 10 bytes
		Fix sized variable	Up to 4 can be set. Fixed size3, variable size1 available
		Variable-sized variable	Only one variable-sized variable can be set. A segment cannot be added at the back of the variable-sized variable.

### 6.5.3 Operation of a user frame definition

Read current value and set temperature value of the temperature controller at intervals of 1 second, save the current value at address M200, and save the temperature set value at address M210.

The frame structure of PC Link which is the communication protocol of Han Young temperature controller used in this example is as follows.

- The frame of the temperature controller is configured with ASCII string and you can read and write the contents of the defined D and I registers. There are two types of protocol: STD standard protocol and SUM protocol with checksum added to the standard type. The protocol type selection is selected by the parameters of the temperature controller. The standard protocol is "STD", and it has the structure that begins with the start character STX (0x02) and ends with the end character CR(0x0D) LF(0x0A).

The following table shows the frame structure of the standard protocol and Check Sum protocol. For the command and data structure, refer to the PLC communication example of Hanyoung Nux Co., Ltd. (<http://hynux.com>).

STX	Station No.	Command	Data	CR	LF
0x02	1~99			0x0D	0x0A

STX	Station No.	Command	Data	Error code	CR	LF
0x02	1~99			Check sum	0x0D	0x0A

#### (1) Writing an example frame

This example is the case of saving the current value and set value of the temperature controller on the M device area of the PLC.

It is a frame that requests reading of data in consecutive area and response frame according to request of reading data.

Frame	STX	Station No.	DRS	,	Data number	D register start address	CR	LF
Size (Byte)	1	2	3	1	4	4	1	1

- DRS: It is a command to read the consecutive values of D register, and the number of data to be read on the frame and the start address of D register should be set.
- In the example, enter 2 for the number of data and 01 for the start address of the current value.

Frame	STX	Station No.	DRS	,	OK	,	Data 1	,	Data N	CR	LF
Size (Byte)	1	2	3	1	2	1	4	1	4	1	1

Send = STX + "01DRS,02,0001" + CR + LF  
 Receive = STX + "01DRS,OK,04D2,0929" + CR + LF

(2) Standard settings

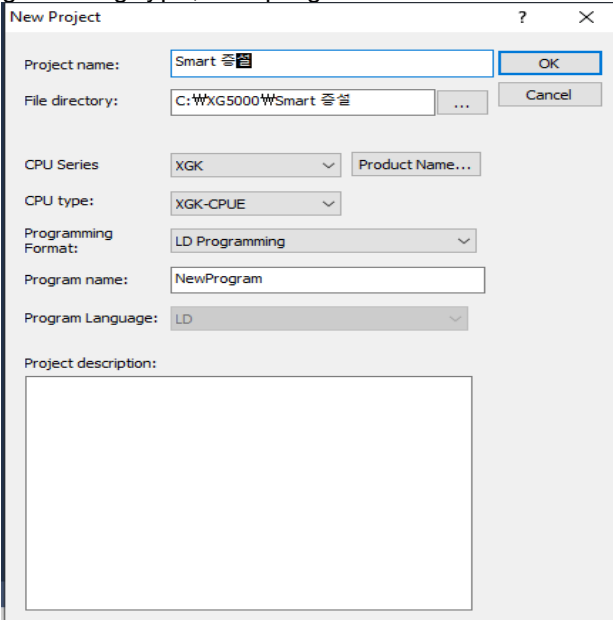
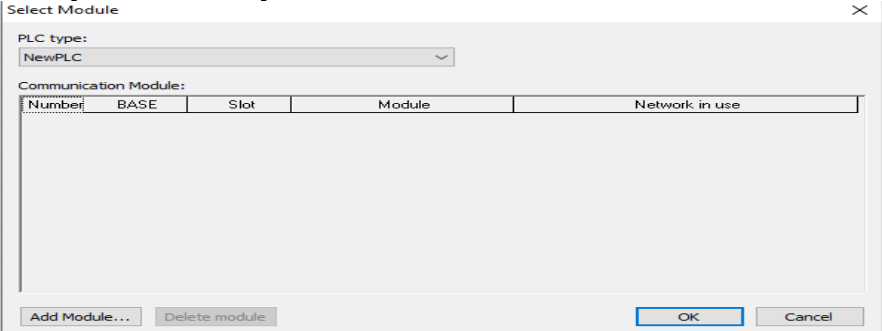
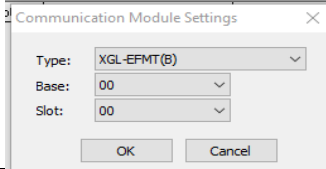
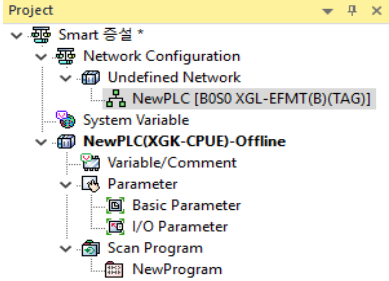
Sequence	Setting process	Setting method
1	Create new project	<p>1) [Project]→Open [New Project] and enter the project name, CPU series, CPU type, programming type, and program name.</p> 
2	Standard network adding	<p>1) Select [Undefined Network]→[Add item]→ [Communication module].                  2) In the [Select Module] window, click “Add module”.</p>  <p>1) Set Type, Base and Slot in Communication module settings. After that, select OK button in [Communication module selection] and module setting is completed.</p> 
3	Undefined Network setting	<p>Double-click the communication module in the [Project] window.</p> 

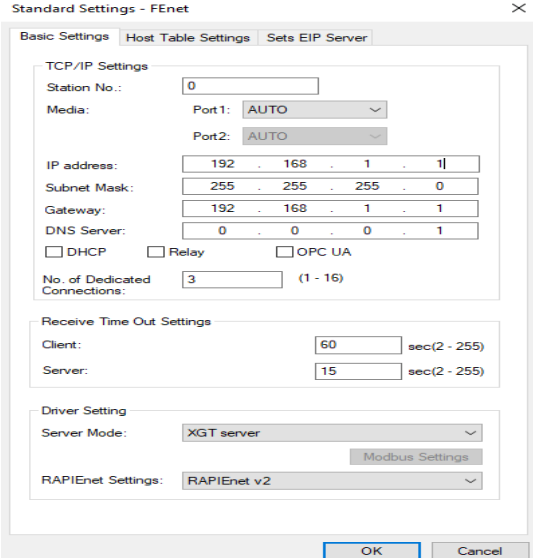
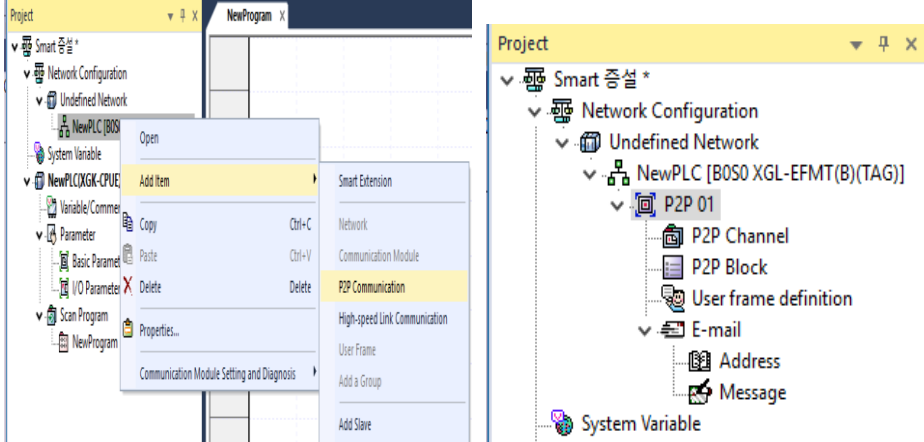
Sequence	Setting process	Setting method
3	Undefined Network setting	<p>Set TCP / IP Settings, Receive time out Settings, and Driver settings on the [Standard Settings] tab.                      1) Set Station No.: 0 and IP address</p> 
4	Adds P2P communication	<p>Select [Add item]→[P2P communication].                      2) The user frame definition is displayed in P2P 01 of the project window.</p> 

(3) Writing send frame

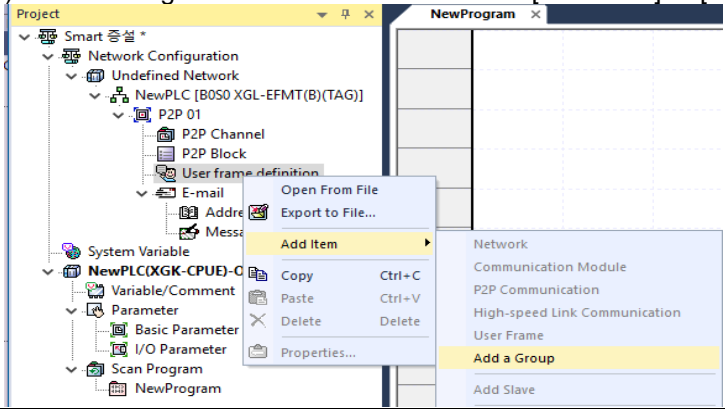
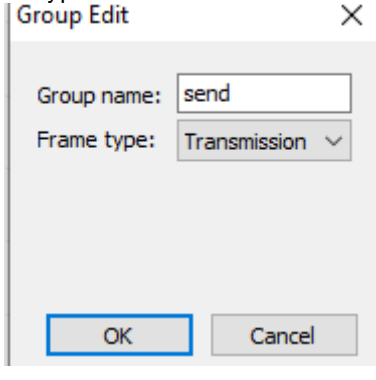
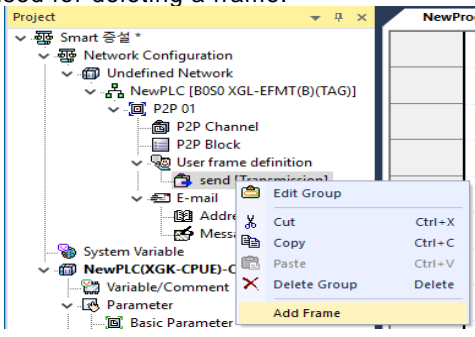
Sequence	Setting process	Setting method
1	Create a user frame	<p>1) Select User frame definition.                      2) Click the right mouse button and select [Add item] → [Add a group].</p> 
2	Edit group	<p>1) The group name indicates the name of a frame that will be created by the user.                      2) Select send for the frame type since the send frame is created currently.</p> 
3	Add frame	<p>1) Select the frame name, right-click and select [Add Frame].                      - Edit group: It is used for changing the frame name.                      - Delete group: It is used for deleting a frame.</p> 

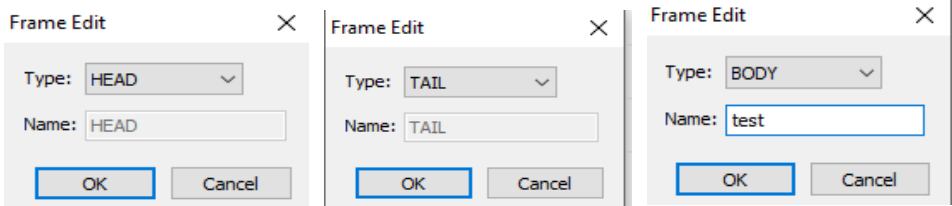
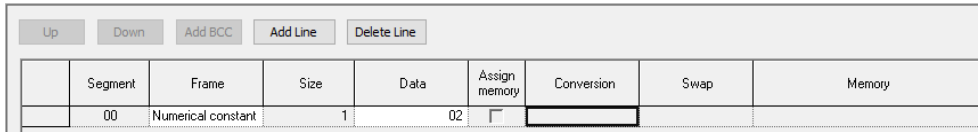
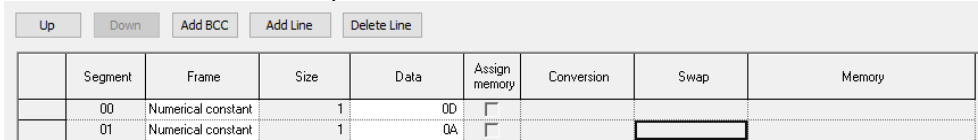
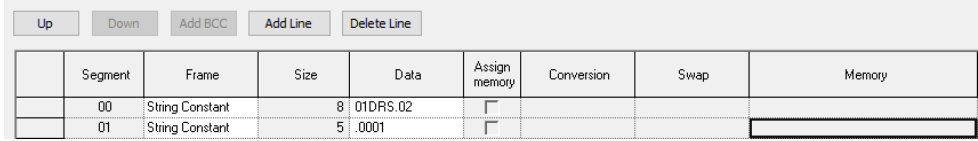
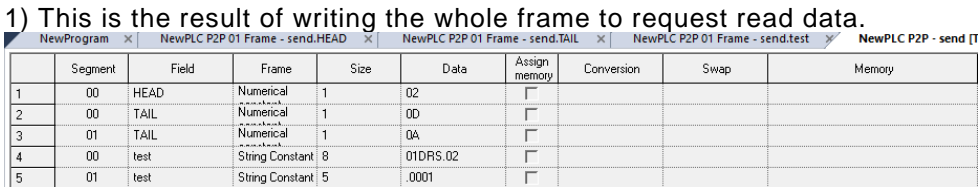
Sequence	Setting process	Setting method
4	register HEAD, TAIL, BODY	<p>1) Click Add Frame and select the frame type HEAD, TAIL, BODY to create.                      2) The name of the frame edit window becomes active only if the type is BODY.                      3) A number of BODY's can be created by using a different name.</p> 
5	Add segment( HEAD)	<p>1) Double click the HEAD item in the project tree to create the segment setting screen.                      2) In addition to the segment, the type is a Numerical constant constant that represents the Hex value in ASCII code, and the data is the Hex value of 2, which means STX.</p> 
6	Add segment( TAIL)	<p>1) In DRS.TAIL, type is Numerical constant constant represented by Hex ASCII code and data is input Hex value D, A which means CR and LF.</p> 
7	Add segment( BODY)	<p>1) Double click the test item to edit the segment as shown below.                      2) Write a frame that requests read data value on two continuous areas with No. 1 of D register in No. 1 station address as the starting address.                      3) When writing a frame through the segment edit on editor screen, the size of each segment is 10 or less.</p> 
8	Send frame	<p>1) This is the result of writing the whole frame to request read data.</p> 

(4) Writing receive frame

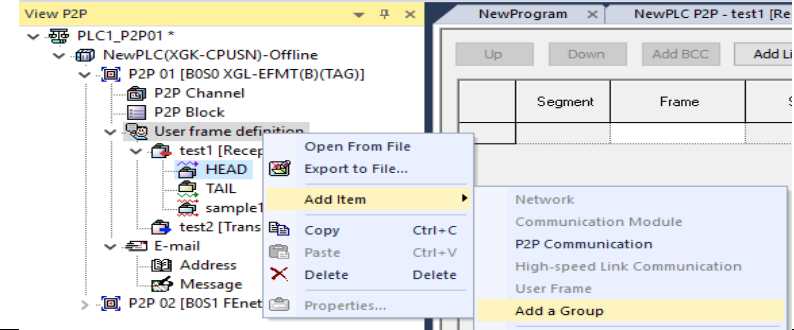
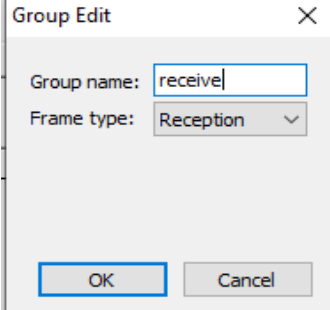
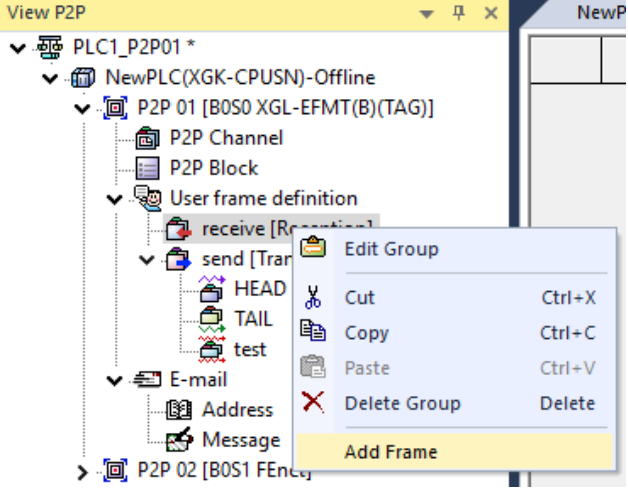
Sequence	Setting process	Setting method
1	Create a user frame	<p>1) Select User frame definition.                      2) Click the right mouse button and select [Add item] → [Add a group].</p> 
2	Edit group	<p>1) The group name indicates the name of a frame that will be created by the user.                      2) Select Reception for the frame type since the reception frame is created currently</p> 
3	Add frame	<p>1) Select the frame name, right-click and select [Add Frame].</p> 

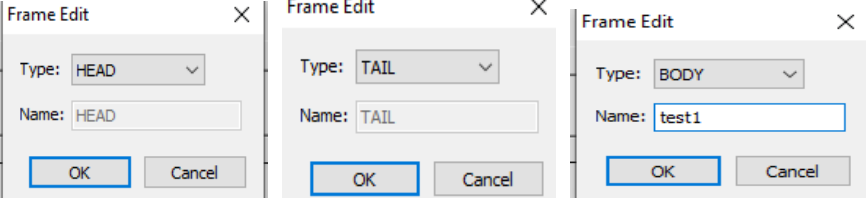
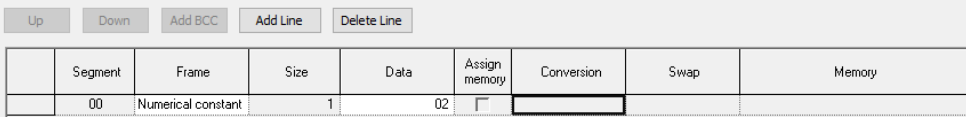
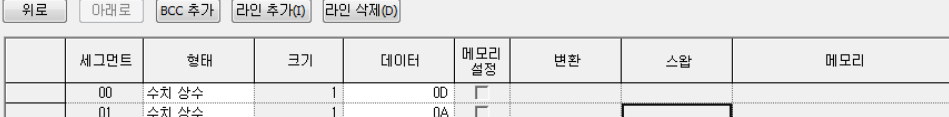
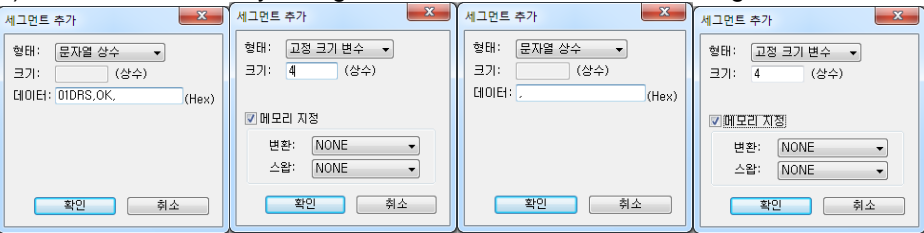
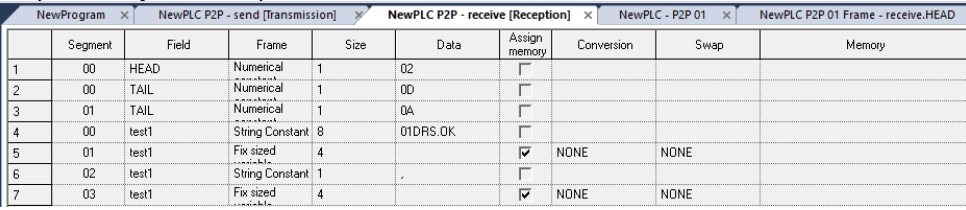
Sequenc e	Setting process	Setting method
4	register HEAD, TAIL, BODY	<p>1) Click Add Frame and select the frame type HEAD, TAIL, BODY to create.                      2) The name of the frame edit window becomes active only if the type is BODY.                      3) A number of BODY's can be created by using a different name.</p> 
5	Add segment( HEAD)	<p>1) Double click the HEAD item in the project tree to create the segment setting screen.                      2) In addition to the segment, the type is a Numerical constant that represents the Hex value in ASCII code, and the data is the Hex value of 2, which means STX.</p> 
6	Add segment( TAIL)	<p>1) In DRS.TAIL, type is Numerical constant constant represented by Hex ASCII code and data is input Hex value D, A which means CR and LF.</p> 
7	Add segment( BODY)	<p>1) Since the present value is saved in MB200 and the set value in MB210, set the and save area area of the 1st and 2nd data.                      2) Since the data size of 1,2 is 4 bytes, set the size as 4 as a fixed sized variable when entering into the segment.                      3) Check the memory assignment to select the data storage area.</p> 
8	Receive total frame	<p>This is the result of writing the whole frame of response that receives data response by the temperature controller.</p> 

(5) Create P2P send / receive block

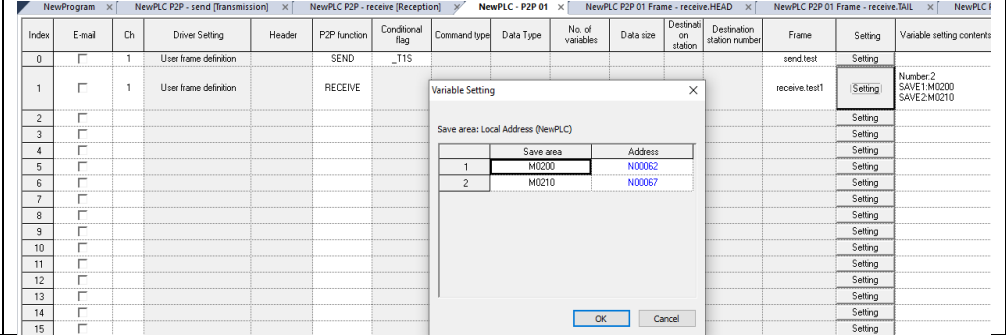
Sequence	Setting process	Setting method
1	Create send / receive block	<p>1) Double click P2P block in P2P 01.                      2) Enter the channel (user frame definition) selected in P2P channel.                      3) In the P2P function, select Send as SEND and Receive as RECEIVE.                      4) The starting condition will be enabled only when the P2P function is SEND.                      5) Use F93 which indicates 1 second for the starting condition since data is read once a second.                      6) Click the setting of the receive frame to set the current temperature value and the and save area area of the set value.</p> 
2	Write parameter	<p>Write [Online]→[Write].                      2) Select [Online]→[Communication Module setting]→[Enable Services].</p>

## 6.6 E-mail Service

E-mail service is a service to notify the remote administrator of the status by using the system when a problem occurs in the system. If the status of the CPU has changed or an event occurred during operation, you can deliver the status using the mail server.

### 6.6.1 Email setting

(1) Click the 'Email' item from the P2P window of XG5000 to activate the 'E-Mail setting screen.

If you check Use E-Mail, the following settings are possible.

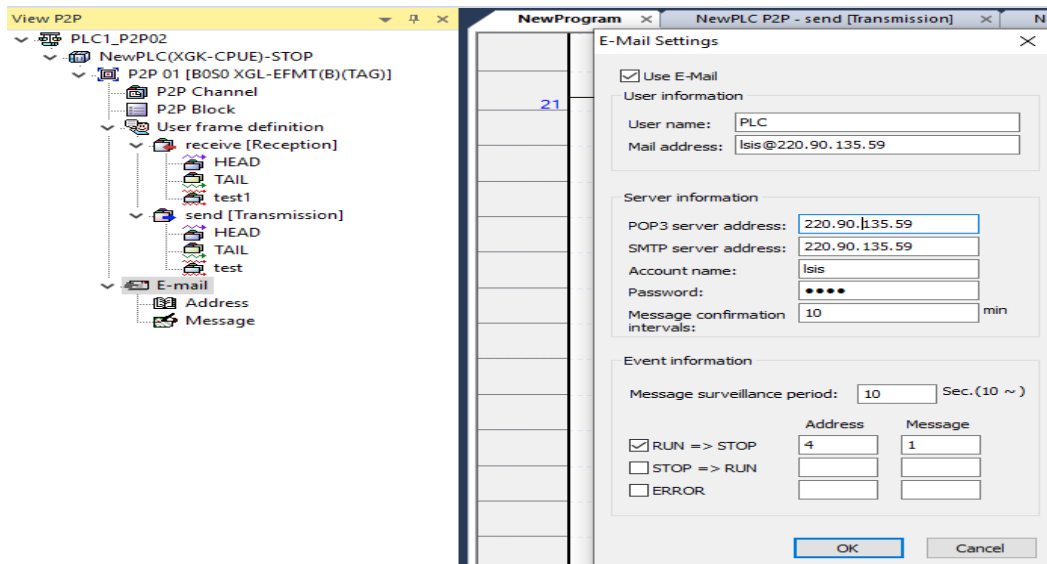

Classification	Item	Usage
	using E-mail	Selects whether or not to use email service. This item must be checked before the email can be used.
User information	User name	Set the user name displayed when the other person receives the mail. When set to PLC, the sender name appears as PLC when receiving mail.
	Mail address	The recipient e-mail address when you clicked Reply. Refers to the sender's mail server consisting of the user name and mail server, and the PLC can send data and the reply can Setting high speed to be received by the PC.
Server information	POP3 server address	Set the IP address to the server address that receives mail from other devices. It can be set as a mail server that supports POP3.
	SMTP server address	The IP address must be set as the server address for the PLC to send data. Can be set to a server that supports SMTP.
	Account name	Set the same account name as the email address in POP3.
	Password	Set a password to access the POP3 account.
	Message confirmation intervals	Set the time to check if a message arrived.
Event information	Message surveillance period	This is the period to check whether the PLC mode has been changed or not.
	RUN -> STOP	When the PLC mode has changed from RUN to STOP, the Ethernet automatically sends an email.
	STOP -> RUN	When the PLC mode has changed from STOP to RUN, the Ethernet automatically sends an email.
	ERROR	When an error occurs during PLC run, the Ethernet automatically sends an email. Sent when an error occurs in RUN, STOP, etc.

The event information determines status information by monitoring the status of the CPU periodically. If the PLC mode is STOP or an error has occurred, the communication parameters will not operate, so this service is provided as an option in preparation for such a case.

6.6.2 Writing address

Double-clicking an address in the E-mail setup section of the P2P screen displays the screen for editing the address book.

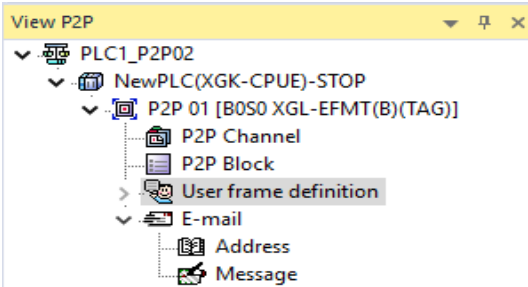

In the screen below, register an address to send a mail.

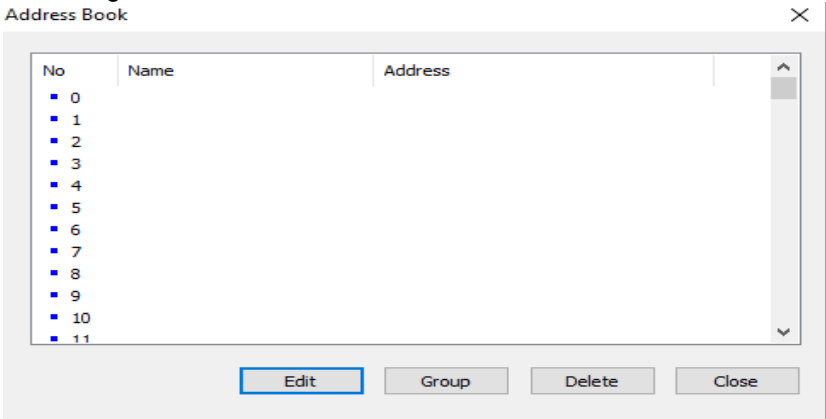

(1) Address Edit

Select Edit to display the Edit Address screen, enter your name and e-mail address, and select OK.

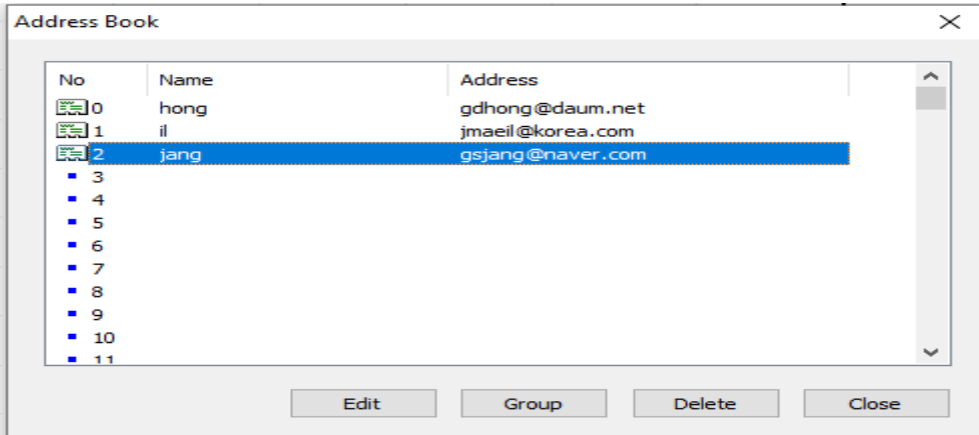
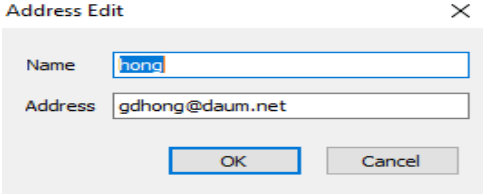

(2) Specified group

Select Group if you want to send the mail to a group instead of individual users at once.

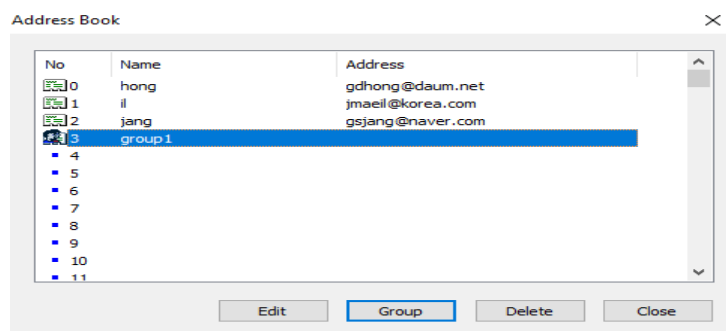
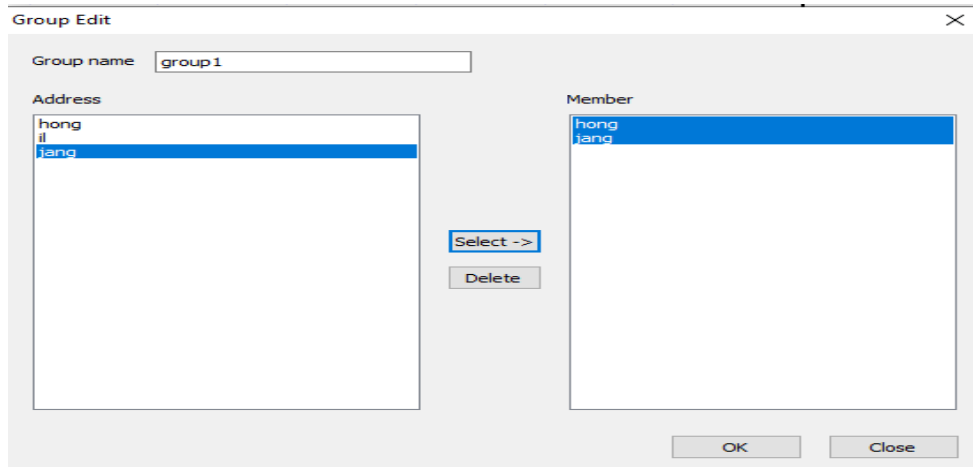

- If you select a group, the personal address book registered so far is displayed on the left screen.
- Select the address of each person who will be a member of the group and click OK to create the group address book.
- If you send to Group 1, the mail will be sent to 'jmaeil' and 'gsjang' at the same time.

(3) Writing a message

If you select a message in the E-mail setup section of the P2P screen, the message edit screen appears.

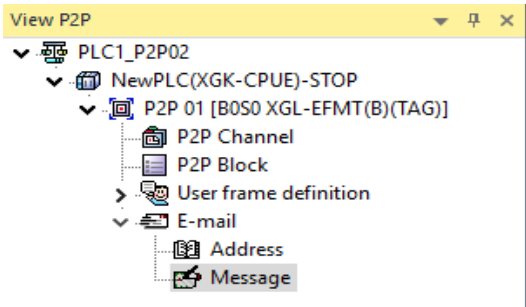

1) Double click message the mail message you want to send.

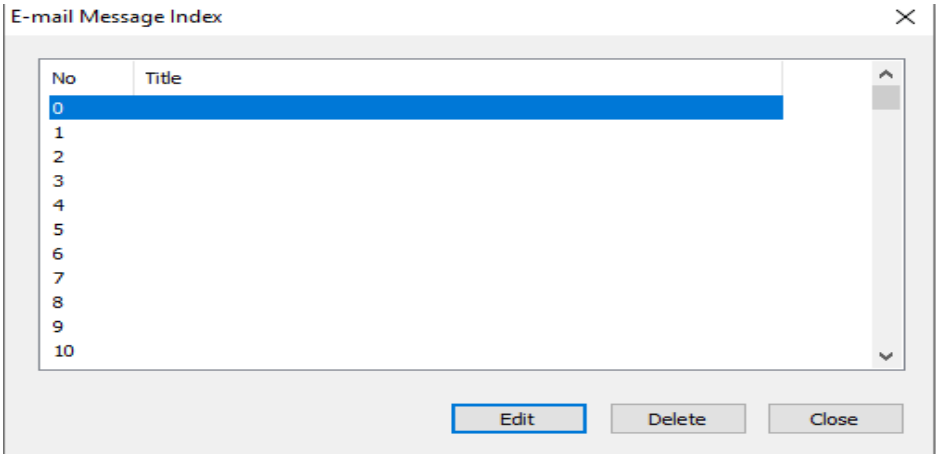

2) Double click the 0 on the above window to display the [E-mail Message] window.

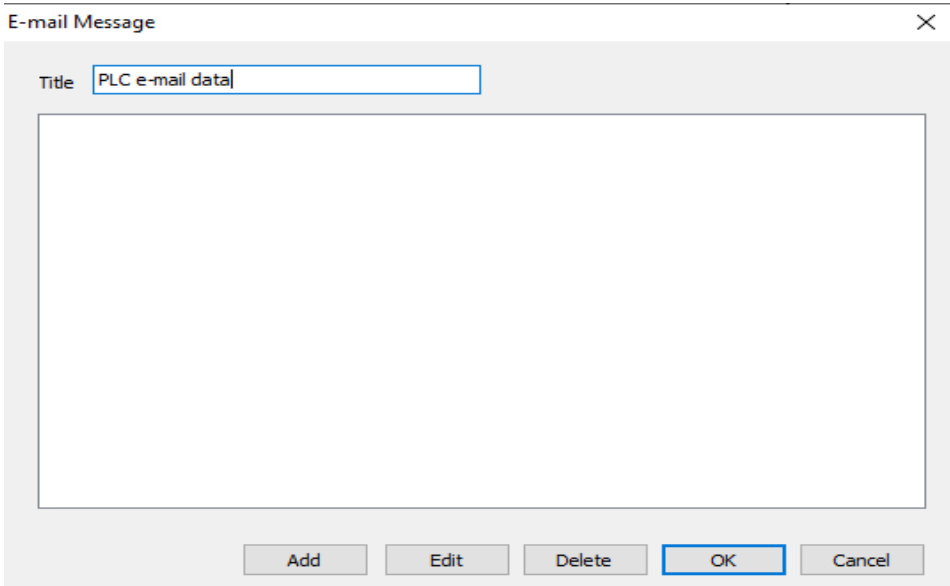

3) Click "Add" to open the [E- mail edit] window.

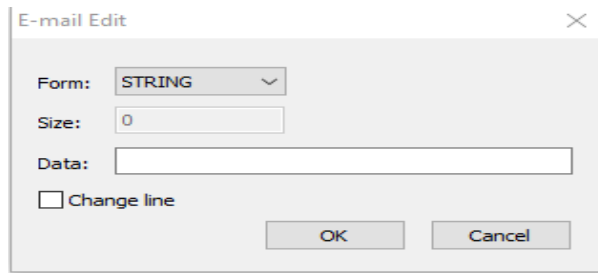

Item	Usage
Form	STRING: It is used to send the message data of P2P ESend parameter to the contents set in the following data. Mb:it is used to send the message data of P2P ESend parameter by the number of bytes set in size.
Size	Specifies the size of the message data. Up to 80 available range be set.
Data	It is activated when STRING is specified in the form and inputs, data.
Change line	Change line means that a command to change the line to the next line is included when the received contents are displayed on the screen.

4) Click "Add" to open the [E- mail edit] window.

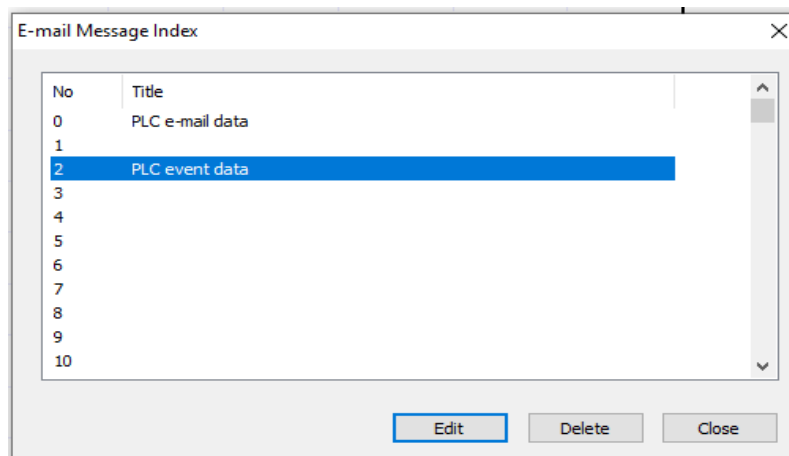
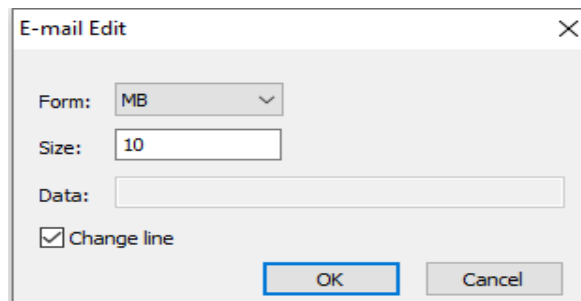

6.6.3 Create block

Parameter setting of P2P block is to send / receive the message of E-mail setting. Click the P2P block and set the E-mail button to select the corresponding P2P command.

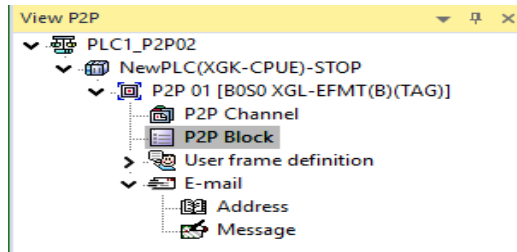

Index	E-mail	Ch	Driver Setting	Header	P2P function	Conditional flag	Command type	Data Type	No. of variables	Data size	Destination station	Destination station number	Frame	Setting	Variable setting contents
0	<input checked="" type="checkbox"/>				ESEND	M00000								Setting	Line:3 Mail Message Number:0 Mail Address Number:0 Mail data:D00000
1	<input checked="" type="checkbox"/>				ERECEIVE	M00001								Setting	Line:2 Mail information:M0010 Mail message:M0100

Classification	Contents
E-mail	Enable your email service.
P2P function	ESEND: Sends an email. ERECEIVE: receives an email. Only one can be registered. .
Start condition	Enter the area to be used as the start condition. Memory areas and flags are available.

(1) Click to enter the settings.

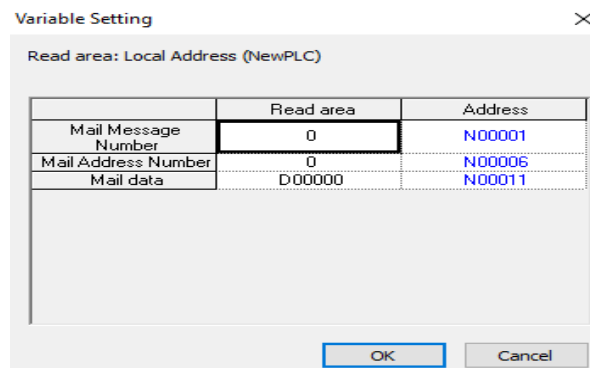

Send	Mail Message Number	Enter the index number from the Message Index among the Email Setting of P2P. Decide the title and data of the mail.
	Mail Address Number	Set the registration number set in the address book. Decide to whom you wish to send mail. * If you want to send it to multiple people, you can set it using a group. However, the mail addresses of the recipient group should have been entered in advance before specifying the group. The number of groups that can be specified is limited to 10 groups.
	Mail data	Indicates the start address of the data to be sent. The size of data to be transmitted is the number of arrays (10 bytes) starting from the first array corresponding to MB [10] within the email message setting.
Receive	Mail information	This is the area where mail information is saved.
	Mail message	Saves a received mail message to the PLC memory.

## 6.7 Downloading and diagnosis of P2P parameter

### 6.7.1 Downloading a P2P parameter

When the P2P parameter setting is completed, you need to download the parameters to the PLC CPU and start the P2P service. To download P2P parameters, select [Online] → [Write] in the XG5000 menu window and the parameter download window will appear. In this window, basic setting, P2P parameter, high speed link parameter registered by user can be selected.

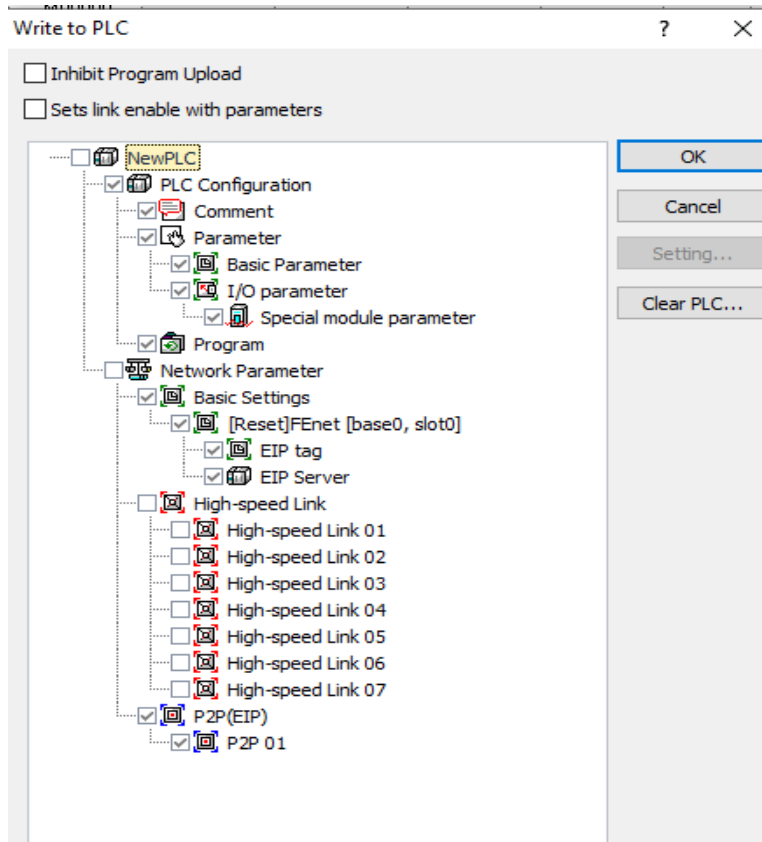

Select only P2P parameters created during P2P 0 ~ 7 and select OK. If confirmed, the P2P parameter is downloaded to the CPU module.

## 6.7.2 P2P service operation

In order to download P2P parameters and start P2P service, P2P operation must be performed. To do this, select [Online] → [Communication module setting and Diagnosis] → [Enable Services (high speed link, P2P)] from the menu.

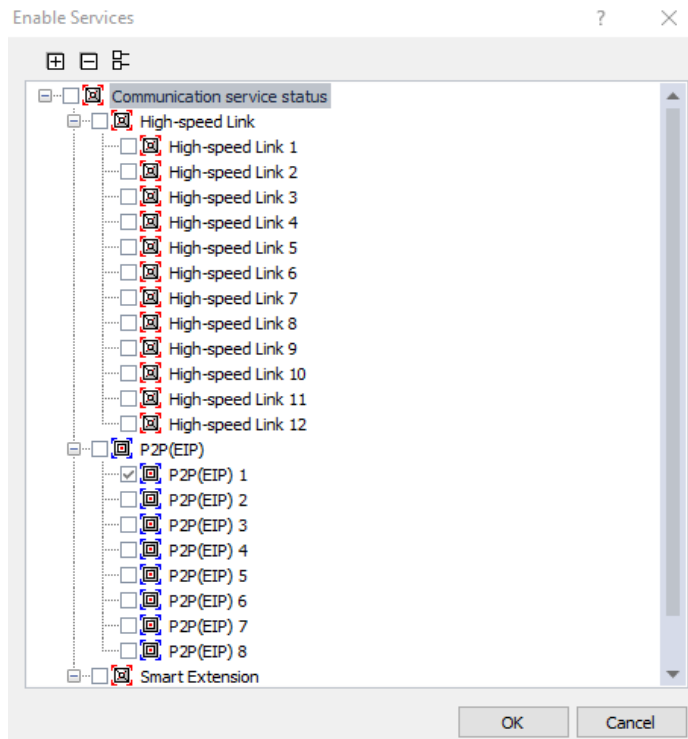

Select a P2P parameter you wish to start from the [Link enable (HS Link, P2P)] window. A P2P parameter which is already checked has started, and if it is canceled, the relevant P2P service will stop. After downloading, check the operation status of P2P service in [System Diagnosis] menu.

6.7.3 P2P service diagnosis

P2P system diagnosis shows the service status and information of communication program after driver setting of communication module. The user can check whether the P2P service is operating normally with the system diagnosis Please refer to the Chapter 3.4 XG5000 program for details.

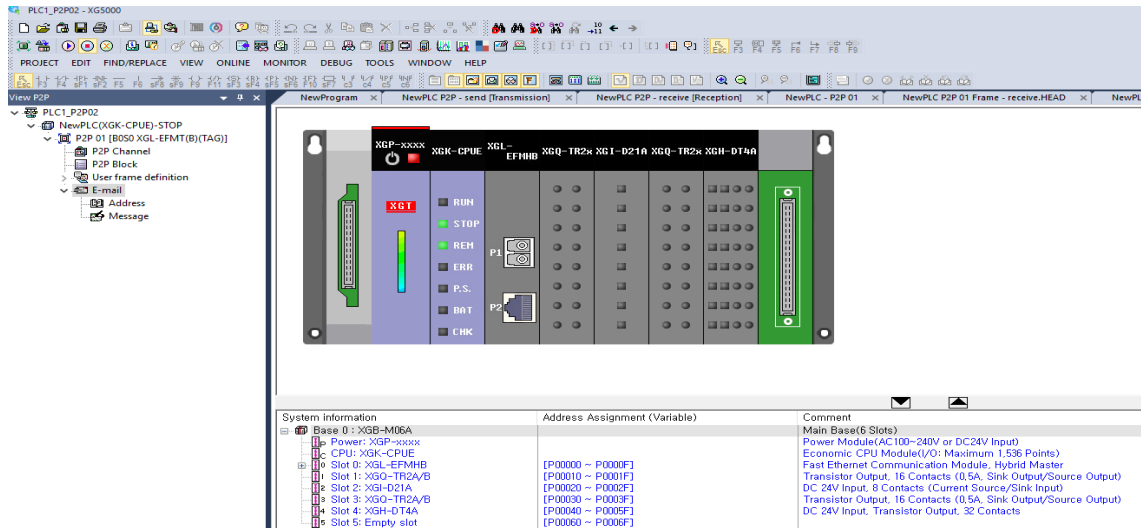

(1) P2P service

Check the status of the user define service in detail. When P2P parameter is set and enabled, it indicates whether the service is normal or not. Real-time monitoring is available by specifying read continuously and refresh on menu.

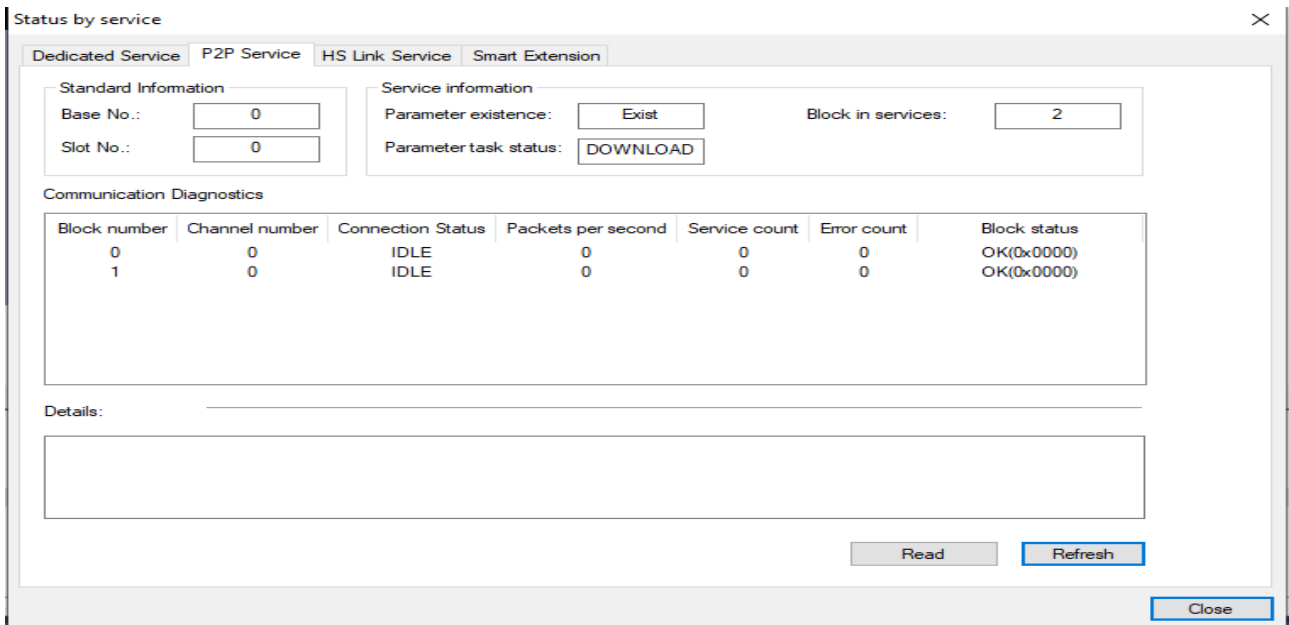

### 6.8XGR Redundancy Program Method

In case of P2P service, in order to read the data of the redundant system, P2P write should be done on the XGK (I) side without using P2P write on the XGR side and use the flag of P2P service. Save normal service count of P2P service connected to A-Side and B-Side and read STATUS of the block to check if it is 0 After that, it checks that STATUS is 0 and normal service count is increased and read the data on either side.

(1) XGR and XGK (I) are redundant with different IP addresses on a single network

In such a case, since the P2P service must be composed of different blocks in one block, the ladder program can be written as follows.

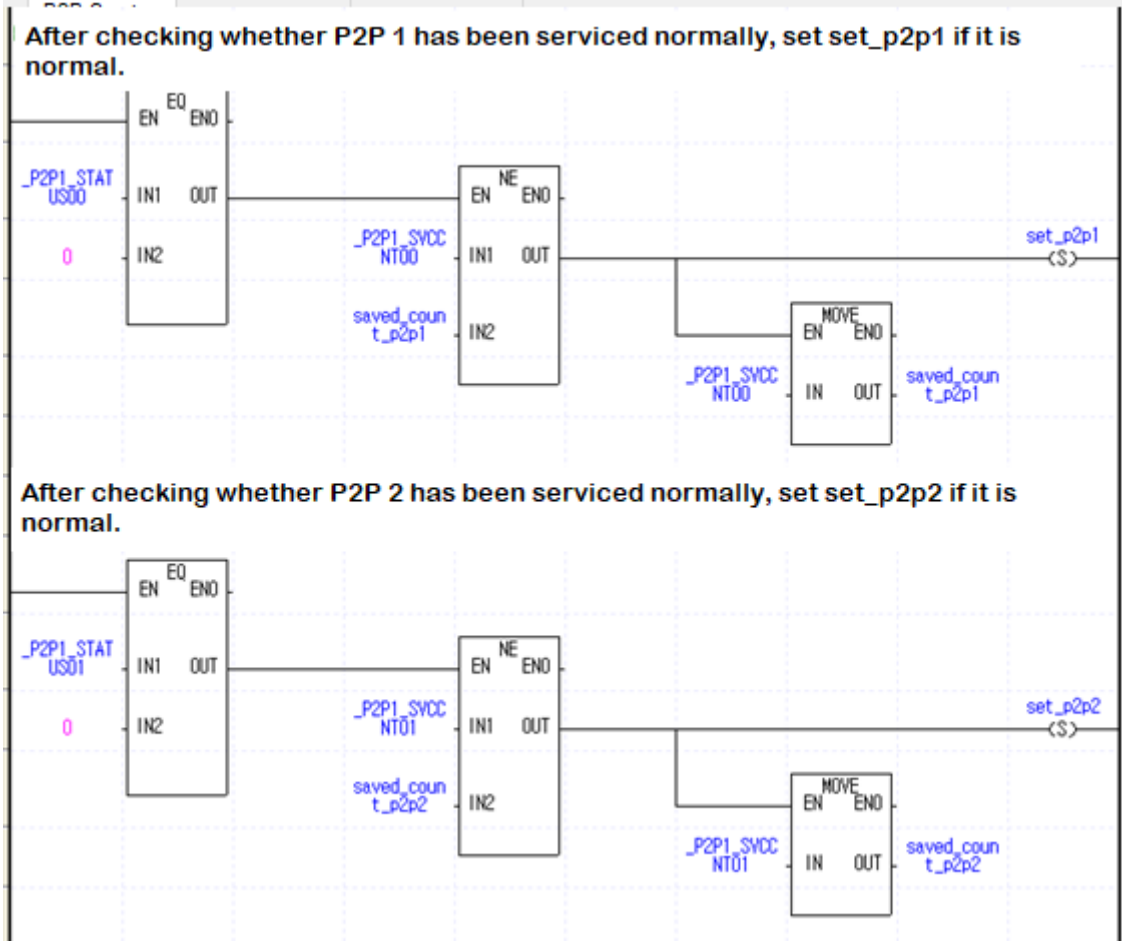

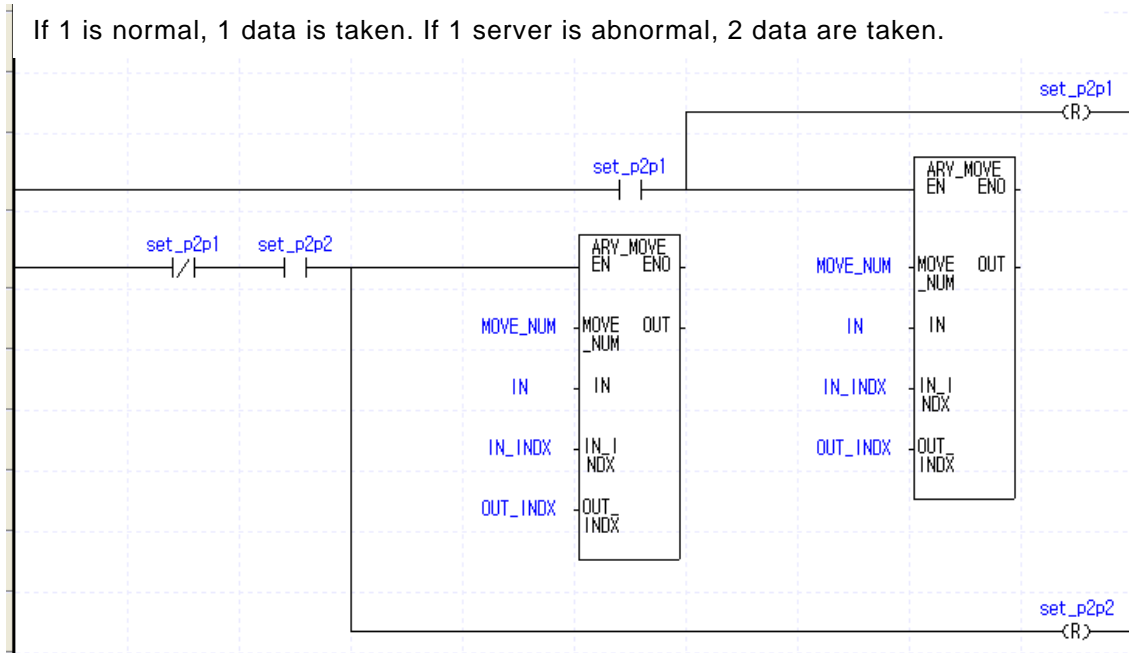

(2) XGR and XGK (I) are redundant with different IP addresses on other (separate) networks.

If you create a ladder in P2P service 1 connected to the master (standby) side, P2P service 2 connected to the standby (master) side and 0 in P2P block 0, you can write as follows.

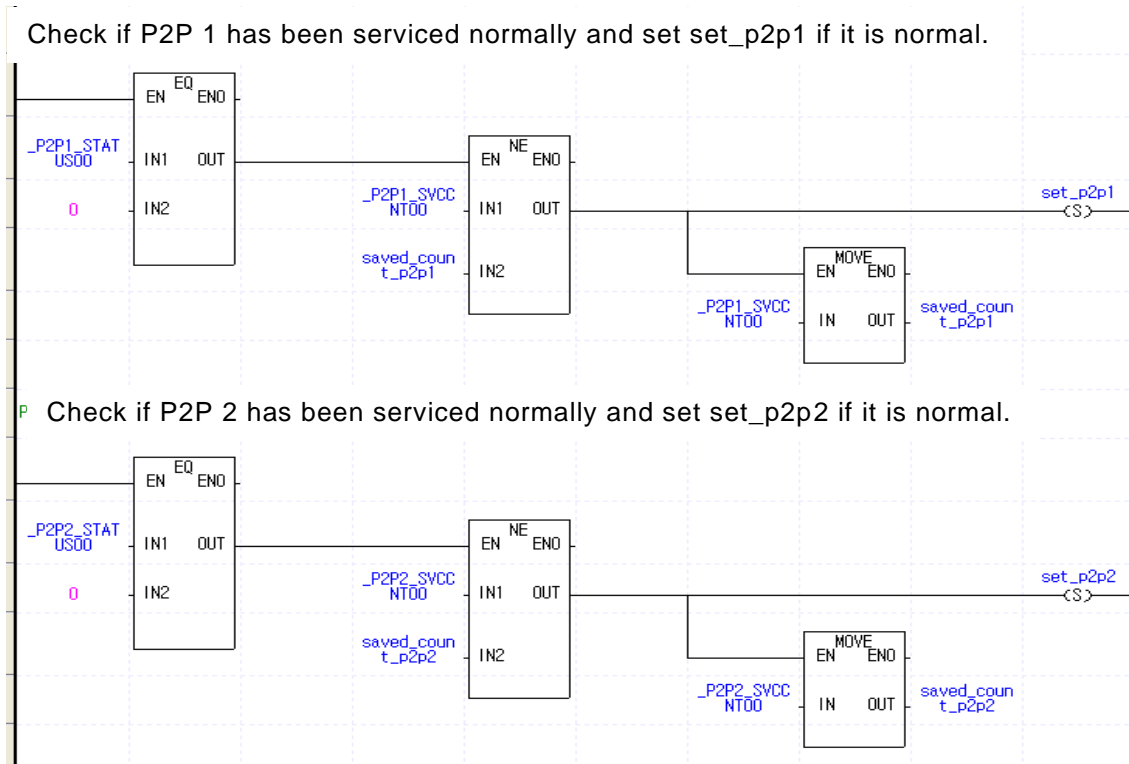

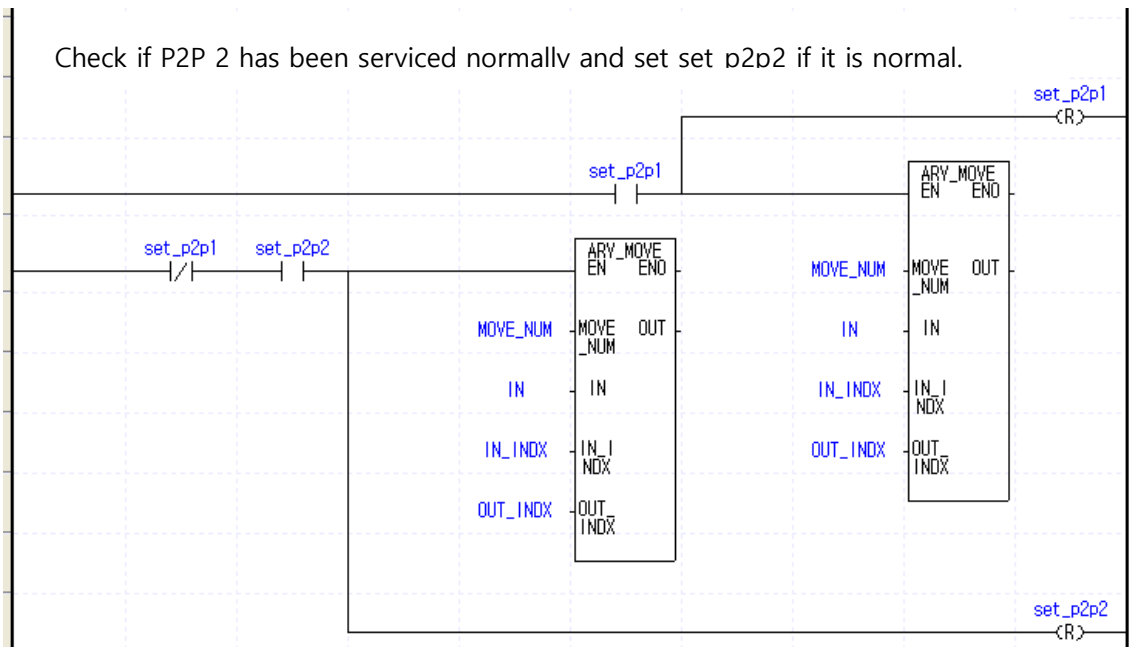

If XGR and XGK (I) are redundantly configured with the same IP address in different (separate) networks, duplicated services can be implemented by writing the same ladder program (2) and the basic part is different. .

## Chapter 7 Server service

Server service is explained by XGT server, Modbus server, EtherNet / IP server, OPC UA server function.

### 7.1 XGT server

#### 7.1.1 Overview

##### (1) Overview of the protocol

XGT dedicated protocol is communication protocol between LS ELECTRIC Ethernet modules. Read / write is available by using command and communication is available by using XGT dedicated protocol from PC and HMI. XGT Dedicated communication can be used in the TCP and UDP communication method.

Protocol	Communication method	Port number
XGT Dedicated	TCP/IP	2004
	UDP/IP	2005

##### (2) Frame structure

###### 1) Structure of XGT dedicated frame

XGT dedicated protocol includes MAC, IP header, TCP header between LS ELECTRIC frame (including data) required for Ethernet communication. The structure of the Ethernet communication frame is shown below.

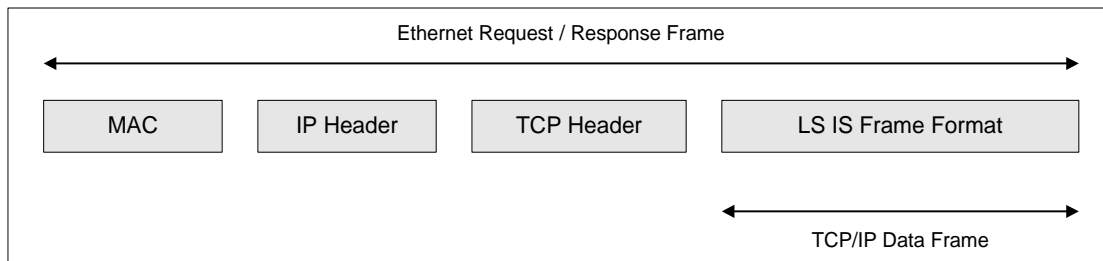

###### 2) Structure of XGT dedicated frame

The LSIS frame for data communication includes LS ELECTRIC's unique data (Company ID), command, data type and data. The frame shape is shown below.

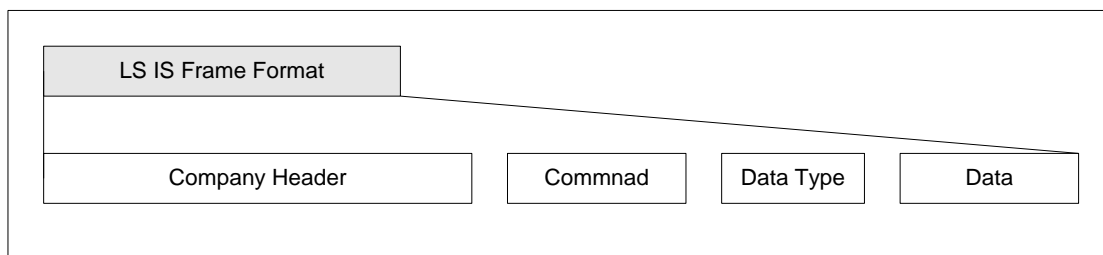

## 3) Header structure of XGT dedicated protocol

Item	Size (Byte)	Contents
Company ID 1	10	-“LSIS-XGT” + “NULL NULL(Reserved)” (ASCII CODE : 4C 53 49 53 2D 58 47 54 00 00)  -“LGIS-GLOFA” (ASCII CODE : 4C 47 49 53 2D 47 4C 4F 46 41)
PLC Info	2	* Client → server: Don't care (0x00) * Server → client: Bit00~05: CPU type (XGK/I/R-CPUH: 0x01, XGK/I-CPUS: 0x02, XGK-CPUA: 0x03, XGK/I-CPUE: 0x04, XGK/I-CPUU: 0x05, XGK-CPUHN: 0x11, XGK-CPUSN: 0x12, XGI-CPUUN: 0x15) Bit06: 0 (Dual Master / single), 1 (Dual Slave) Bit07: 0 (CPU normal operation), 1 (CPU Error operation) Bit08~12: system status (RUN :0x01, STOP: 0x02, ERROR :0x04, DEBUG :0x08) Bit13~15: Reserved
CPU Info	1	It is determined that it is XGK / XGI / XGR series. - XGK: 0xA0                      - XGB(MK): 0xB0 - XGI: 0xA4                      - XGB(IEC): 0xB4 - XGR: 0xA8
Source of Frame	1	* Client(HMI) → Server(PLC) : 0x33 * Server(PLC) → Client(HMI) : 0x11
Invoke ID	2	ID to distinguish order between frames (Send this number to the response frame)
Length	2	Byte size instruction structure
Ethernet location	1	Bit0~ 3: Slot no. of Ethernet module Bit4~ 7: Base no. of Ethernet module
Reserved 2 (BCC)	1	0x00: Reserved area (Byte sum of Header)

## Notes

- (1) Length means the sum of the size of (command frame) bytes from command to data number or data.
- (2) Reserve 2 (BCC) is a 1 byte value from the sum of the frame contents from Company ID to Ethernet position.  
(If the 4C+53+49+53 values are added together, it is 13B and only the lower byte, 3B, is displayed.)

4) Frame structure of XGT dedicated protocol

- Command request frame(External communication device → Ethernet I/F module)

Header	Command	Data type	Reserved area (2 Byte)	Structured data area
--------	---------	-----------	---------------------------	----------------------

- ACK response frame (Ethernet module → external communication device, when data is received normally)

Header	Command	Data type	Reserved area (2 Byte)	Error status (2 Byte: h'0000)	Structured data area
--------	---------	-----------	---------------------------	----------------------------------	----------------------

- NAK response frame (Ethernet module → external communication device, when data is not received normally)

Header	Command	Data type	Reserved area (2 Byte)	Error status (2 Byte value is not h'0000)	Error code (2 Byte)
--------	---------	-----------	---------------------------	--	------------------------

4 types of command are used in the XGT dedicated protocol and each command processes read/write and request/response.

Available data type of each instruction is bit, byte, word, double word, long word or is individual and data type is only byte if it is consecutive.

Command	Command code	Data type			Contents
Read	Request: h'0054	Individual	h' 0000	BIT	Request to read data according to each data
			h' 0001	BYTE	
			h' 0002	WORD	
			h' 0003	DWORD	
			h' 0004	LWORD	
	Continuous	h' 0014	BYTE	Request to read byte variable in blocks	
	Reponse: h'0055	Individual	h' 0000	BIT	Response to the request for Read Data
			h' 0001	BYTE	
			h' 0002	WORD	
			h' 0003	DWORD	
h' 0004			LWORD		
Continuous	h' 0014	BYTE	Response to the request for block unit Read		
Write	Request: h'0058	Individual	h' 0000	BIT	Request to Write Data according to each data
			h' 0001	BYTE	
			h' 0002	WORD	
			h' 0003	DWORD	
			h' 0004	LWORD	
	Continuous	h' 0014	BYTE	Request to write byte variable in blocks	
	Reponse: h'0059	Individual	h' 0000	BIT	Response to the request for Write Data
			h' 0001	BYTE	
			h' 0002	WORD	
			h' 0003	DWORD	
h' 0004			LWORD		
Continuous	h' 0014	BYTE	Response to the request for block unit read		

- Expression of data type: Device Type of XGT PLC: Data types for variables such as P, I, Q, M, L, F, K, C, D, T, N, and R are displayed after the variable display character '%' (H25).

Data type	Example
Bit	%PX0,%LX0,%FX0
Byte	%MB0, %PB0, %DB0
Word	%PW0,%LW0,%FW0,%DW0
DWord	%PD0,%LD0,%FD0,%DD0
LWord	%PL0,%LL0,%FL0,%DL0

#### Notes

- (1) In Timer/Counter, the Bit specification means the contact value and the Byte and Word value specification means the current value.
- (3) Only Byte and Word can be specified for the data register (D).
- (4) In case of a byte type command, the address value will be doubled in comparison to specifying Word. In other words, in case of D1234, %DW1234 is used when Word is specified, but in case the form of Byte is specified, %DB2468 should be used.
- (5) When accessing the bit area, it should be expressed in the order of data type unit of memory device. in order to write the C th bit of M172, M should be calculated as bit type as below because it is word device.  
\* %MX2764 = 172 x 16(Word) + 12(Bit)
- (6) In the case of hexadecimal data before the number in the frame, it indicates that the data is in hexadecimal type by 'h' or '0x', such as h'12345, h'34, 0x12, 0x89AB.
- (7) When creating a frame, when expressing hexadecimal word data in the above frame, subtract h before the number and change the position of two bytes.  
ex) h'0054 ⇒ h'5400.

7.1.2 XGT dedicated protocol commands

(1) Read variable individually

This is the function to specify the PLC device memory to read according to the memory data type. 16 independent device memories can be read at a time.

1) Request frame

Item	Size (Byte)	Contents
Command	2	0x0054: read request
Data type	2	Refer to the data type table(X, B, W, D, L)
Reserved area	2	0x0000: Don't Care
Number of blocks	2	The number of variables to be read is up to 16.
Length of variable name	2	The length of direct variable is up to 16 characters.
Variable name	Length of variable name	Only direct variables are available
...	...	(Repeat as many as the number of variables/max. 16)
Length of variable name	2	The length of direct variable is up to 16 characters.
Variable name	Length of variable name	Only direct variables are available

Name of frame	Header	Command	Data type	Reserved area	Number of block	Length of variable name	Variable name	...
Code(ex)	...	h'0054	h'0002	h'0000	h'0001	h'0006	%MW100	

1 block (Up to 16 blocks can be set repeatedly)

- Blocks number: By specifying how many blocks composed of [variable names] and [length of variable] are in the request frame, up to 16 blocks can be set. Therefore, the value of [Number of blocks] should be h'0001 ~ h'0010.
- Length of variable name: It indicates the number of letters of a name that means a variable, and a maximum of 16 characters is allowed. Therefore, the value of [length of variable name] should be h'0001 ~ h'0010.
- Variable name: The variable address to be read is entered. It must be an ASCII value within 16 characters, and other than numbers, upper/lower case, '%' and '.' are not allowed in this variable name.

2) Response frame(ACK response)

Item	Size (Byte)	Contents
Command	2	0x0055: Read response
Data type	2	Refer to the data type table
Reserved area	2	0x0000 : Don't Care
Error status	2	If it is 0, it is normal, if it is not 0, it is an error.
Error information	2	In case of error, the lower byte is the error number

Number of blocks		Number of variables to read when the error status is normal
Data size	2	Byte size of data
Data	Data size	Data to read
...	...	(Repeat as many as the number of variables/max. 16)
Data size	2	Byte size of data
Data	Data size	Data to read

Name of frame	Header	Command	Data type	Reserved area	Error status	Number of blocks	Data size	Data	.....
Code(ex)	...	h'0055	h'0002	h'0000	h'0000	h'0001	h'0002	h'1234	

1 block(Max. 16 blocks)

- Blocks Number: By specifying how many blocks composed of [variable length] and [data] are in the response frame, up to 16 EA can be set. Therefore, the value of [Number of blocks] should be h'0001 ~ h'0010.
- Data size: It means the number of bytes of HEX type. This number is determined by the memory type (X, B, W, D, L) contained in the variable name of the computer request frame.

3) Response frame(NAK response)

Name of frame	Header	Command	Data type	Reserved area	Error status	Error code (Hex 2 Byte)
Code(ex)	...	h'0055	h'0002	h'0000	h'FFFF or h'00FF (Non-zero value)	h'0021

**Notes**

- (1) The error code is a hexadecimal 2 byte and indicates the type of error. For details, refer to the 'Error Code Table.'

(2) Variable continuous read

This is a function that directly designates the PLC device memory and continuously reads data as much as the specified amount from the specified address.

1) Request frame

Item	Size (Byte)	Contents
Command	2	0x0054: read request
Data type	2	0x0014: continuous
Reserved area	2	0x0000: Don't Care.
Number of blocks	2	The number of variables to be read is up to 16.
Length of variable name	2	The length of variable name is up to 16 characters.
Variable name	Length of variable name	Only direct variables can be used and indicate the first address of the block.
The number of data	2	Byte size of data, Max. 1400Byte

Name of frame	Header	Command	Data type	Reserved area	Number of blocks	Length of variable name	Variable name	The number of data
Code(ex)	...	h'0054	h'0014	h'0000	h'0001	h'0006	%MB000	h'0006

- Data type: Data type can only be used as h'0014.
- Blocks Number: The number of blocks can only be used as h'0001.
- Length of variable name: It indicates the number of letters of a name that means a variable, and a maximum of 16 characters is allowed. Therefore, the value of [length of variable name] should be h'0001 ~ h'0010.
- Variable name: The variable address to be read is entered. It must be an ASCII value within 16 characters, and other than numbers, upper/lower case, '%' and '.' are not allowed in this variable name.

2) Response frame(ACK response)

Item	Size (Byte)	Contents
Command	2	0x0055: READ response
Data type	2	0x0014: continuous
Reserved area	2	0x0000: Don't Care
Error status	2	If it is 0, it is normal, if it is not 0, it is an error.
Error information	2	In case of error, the lower byte is the error number
No. of variables		0X0001: Normal operation
Data size	2	Byte size of data
Data	Data size	Data to read, max. 1400 Byte

Name of frame	Header	Command	Data type	Reserved area	Error status	Number of blocks	The number of data	Data
Code(ex)	...	h'0055	h'0014	h'0000	h'0000	h'0001	h'0006	h'0123456789AB

3) Response frame(NAK response)

Name of frame	Header	Command	Data type	Reserved area	Error status	Error code (Hex 2 Byte)
Code(ex)	...	h'0055	h'0014	h'0000	h'FFFF or h'00FF (Non-zero value)	h'0021

(3) Write variable individually

This is the function to specify the PLC device memory to write according to the memory data type. Data can be written to 16 independent device memories at once.

1) Request frame

Item	Size (Byte)	Contents
Command	2	0x0058: Write request
Data type	2	Refer to the data type table
Reserved area	2	0x0000: Don't Care
Number of blocks	2	The number of variables to be write is up to 16.
Length of variable name	2	The length of direct variable is up to 16 characters.
Variable name	Length of variable name	Only direct variables are available
...	...	(Repeat as many as the number of variables/max. 16)
Length of variable name	2	The length of direct variable is up to 16 characters.
Variable name	Length of variable name	Only direct variables are available
Data size	2	Byte size of data
Data	Data size	Data to write
...	...	(Repeat as many as the number of variables/max. 16)
Data size	2	Byte size of data
Data	Data size	Data to write

Name of frame	Header	Command	Data type	Reserved area	Number of blocks	Length of variable name	Variable name	..	Data Size	Data	..
Code(ex)	..	h'0058	h'0002	h'0000	h'0002	h'0006	%MW100	..	h'0002	h'1234	..

1 block (Up to 16 blocks can be set repeatedly)

- Blocks Number: By designating the number of blocks composed of '[variable name length][variable name][data size][data]' in the request frame, up to 16 blocks can be set. Therefore, the value of [Number of blocks] should be h'0001 ~ h'0010.
- Length of variable name: It indicates the number of letters of a name that means a variable, and a maximum of 16 characters is allowed. Therefore, the value of [length of variable name] should be h'0001 ~ h'0010.
- Variable name: The variable address to be read is entered. It must be an ASCII value within 16 characters, and other than numbers, upper/lower case, '%' and '.' are not allowed in this , variable name.

**Notes**

(1) The device data type of each block should be same. If the data type of the first block is Word and the data type of the second block is Double Word, an error occurred.  
 If the data type is Bool, the read data is displayed in HEX as one byte. In other words, if the bit value is 0, h00 will be displayed, and if the bit value is 1, h'01 will be displayed.

2) Response frame(ACK response)

Name of frame	Header	Command	Data type	Reserved area	Error status	Number of blocks
Code(ex)	...	h'0059	h'0002	h'0000	h'0000	h'0001

- Blocks number: Displays the number of blocks to be written normally.

3) Response frame(NAK response)

Name of frame	Header	Command	Data type	Reserved area	Error status	Error code (Hex 2 Byte)
Code(ex)	...	h'0059	h'0002	h'0000	h'FFFF or h'00FF (Non-zero value)	h'0021

(4) Write variable continuously

This is the function to specify the PLC device memory to write the data. This is the function to write continuously as much data as the specified quantity, starting from the specified address. However, only byte type variables can be used.

1) Request frame

Item	Size (Byte)	Contents
Command	2	0x0058: Write request
Data type	2	0x0014: continuous
Reserved area	2	0x0000: Don't Care.
Number of blocks	2	The number of variables to be write is 0x0001.
Length of variable name	2	The length of variable name is up to 16 characters.
Variable name	Length of variable name	Only direct variables can be used and indicate the first address of the block(% MB0,% PB0)
Data size	Data size	Byte size of data
Data	Data size	The number of data to write is up to 1400byte.

Name of frame	Header	Command	Data type	Reserved area	Number of blocks	Length of variable name	Variable name	Data size	Data
Code(ex)	...	h'0058	h'0014	h'0000	h'0001	h'0006	%MB100	h'0002	h'1234

- Data type: Data type can only be used as h'0014.
- Blocks Number: The number of blocks can only be used as h'0001.
- Length of variable name: It indicates the number of letters of a name that means a variable, and a maximum of 16 characters is allowed. Therefore, the value of [length of variable name] should be h'0001 ~ h'0010.
- Variable name: The address of the variable to write must be an ASCII value within 16 characters, and other than numbers, upper and lower case letters, '%' and '.' are not allowed in the variable name.
- Data size: It indicates the number of bytes of data (max. 1,400 bytes).

2) Response frame(ACK response)

Item	Size (Byte)	Contents
Command	2	0x0059: Write response
Data type	2	0x0014: continuous
Reserved area	2	0x0000: Don't Care
Error status	2	If it is 0, it is normal, if it is not 0, it is an error.
Error information	2	In case of error, the lower byte is the error number
No. of variables		0X0001: Normal operation

3) Response frame(NAK response)

Frame name	Header	Command	Data type	Reserved area	Error status	Error code (Hex 2 Byte)
Code(ex)	....	h'0059	h'0014	h'0000	h'FFFF or h'00FF (Non-zero value)	h'0021

(5) Request to read information and status(PC/HMI -> PLC)

It is a service that can use PLC information and status through communication.

1) Computer requirements frame

Item	Size (Byte)	Content
Command	2	0x00B0: Status Request
Data type	2	0x0000: Ignore
Reserved area	2	0x0000: Ignore

2) Response Frame(when the ACK response from PLC)

Item	Size (Byte)	Content
Command	2	0x00B1: Status request
Data type	2	0x0000: Ignore
Reserved area	2	0x0000: Ignore
Error status	2	If it is 0, it is normal, if it is not 0, it is an error code.
Reserved area	2	0x0000: Ignore
Data size	2	0x0018
Data	24	Status Data

3) XGT Status Data Structure

Item	Size (Byte)	Byte Position	Content
Slot Info	4	0	Slot info Bit00~ Bit03: Slot information remotely connected to another station Bit04~ Bit07: Base information remotely connected to another station Bit08~ Bit11: Slot information remotely connected to another station Bit12~ Bit15: Base information remotely connected to another station Bit16~ Bit19: Slot information on which Ethernet module is mounted Bit20~ Bit23: Base information on which Ethernet module is mounted Bit24~Bit31: Reserved area
_CPU_TYPE	2	4	System type: Flag
_PADT_CNF	2	6	XG5000 Connection status: flag
_SYS_STATE	4	8	PLC mode and operation states: flag
_CNF_ER	4	12	System error(Breakdown): Flag
_CNF_WAR	4	16	System Warning: Flag
_VER_NUM	2	20	OS version No.: Flag
Reserved	2	22	Reserved area

\* Refer to "4) Flag description" for detailed description of each item.

4) Flag description

\_CPU\_TYPE

Bit 15 (0) : XGI , Bit 15(1) : XGK

Bit 15(0) : Single, Dual master0) , Bit 15(1) : Dual slave

(ex, Single: 0x8000~0xffff, XGK-CPUH :0xA001, XGK-CPUS: 0xA002)

\_VER\_NUM

0xXXYY: xx.yy

\_SYS\_STATE

Displays the operation mode and operation status of the system. (DWORD, F00~F01)

Variable	Position	Device	Function	Description
_RUN	Bit0	F00000	RUN	CPU module operation status is RUN
_STOP	Bit1	F00001	STOP	CPU module operation status is STOP
_ERROR	Bit2	F00002	ERROR	CPU module operation status is ERROR
_DEBUG	Bit3	F00003	DEBUG	CPU module operation status is DEBUG
_LOCAL_CON	Bit4	F00004	Local control	Operation mode can be changed only by mode key
_MODBUS_CON	Bit5	F00005	Modbus mode on	Modbus slave in service
_REMOTE_CON	Bit6	F00006	Remote mode on	Remote mode run
-	Bit7	F00007	-	-
_RUN_EDIT_ST	Bit8	F00008	Editing during RUN (Downloading program)	Waiting for modified program when modifying during run
_RUN_EDIT_CHK	Bit9	F00009	Editing while running(Internal processing)	Internal processing when modifying during run
_RUN_EDIT_DONE	Bit10	F0000A	Edit done during RUN	Modification completed successfully during run
_RUN_EDIT_END	Bit11	F0000B	Internal flag to indicate when modification is complete during run	Modification completed successfully during run
_CMOD_KEY	Bit12	F0000C	Operation mode change	Change operation mode by key
_CMOD_LPADT	Bit13	F0000D	Operation mode change	Change run mode by local PADT
_CMOD_RPADT	Bit14	F0000E	Operation mode change	Operation mode change by remote PADT
_CMOD_RLINK	Bit15	F0000F	Operation mode change	Operation mode change by remote communication module
_FORCE_IN	Bit16	F00010	Forced input	Forced On / Off execution of input contact
_FORCE_OUT	Bit17	F00011	Forced output	Forced On / Off execution of output contact
_SKIP_ON	Bit18	F00012	Executing I/O skips	There is an input / output module specified to stop fault checking and data refresh.
_EMASK_ON	Bit19	F00013	Executing fault mask	There is an I / O module designated to continue operation even if a fault occurs
_MON_ON	Bit20	F00014	Monitoring	Running external monitor for program and variable
_USTOP_ON	Bit21	F00015	Stop by Stop function	Stop after scan completion by STOP function during RUN mode
_ESTOP_ON	Bit22	F00016	Stop by ESTOP function	Immediate stop by ESTOP function during RUN mode operation
_CONPILE_MODE	Bit23	F00017	Compiling	Compiling

Variable	Position	Device	Function	Description
_INIT_RUN	Bit24	F00018	Initializing	Performing initialization task.
-	Bit25	F00019	-	-
-	Bit26	F0001A	-	-
-	Bit27	F0001B	-	-
_PB1	Bit28	F0001C	Program code 1	Program code 1 is being executed
_PB2	Bit29	F0001D	Program code 2	Program code 2 is being executed
_CB1	Bit30	F0001E	Compile code 1	Compilation code 1 is being executed
_CB2	Bit31	F0001F	Compile code 2	Compilation code 2 is being executed

### \_CNF\_ER

Collective display of error flags related to operation stop failure.

Variable	Type	Device	Function	Description
_CPU_ER	Bit	F00020	CPU configuration error	If normal operation is not possible due to self-diagnosis error of CPU module
_IO_TYER	Bit	F00021	Module type mismatch error	If the configuration of the mounting module and I / O parameters of each slot are different
_IO_DEER	Bit	F00022	Module detachment error	Detects when the module configuration of each slot is changed during operation.
_FUSE_ER	Bit	F00023	Fuse cutoff error	Detect when the fuse of the module with the fuse of each slot is broken
_IO_RWER	Bit	F00024	I/O module read/write error	An error occurs when the I / O module among the modules in each slot cannot be read / written normally.
_IP_IFER	Bit	F00025	Special / communication module Interface error	Normal connection is not possible due to malfunction of special / communication module among modules in each slot.
_ANNUM_ER	Bit	F00026	Significant error detection in external device	Fault detection when a failure of external device is detected by user program and recorded in ANC_ERR [n]
-	Bit	F00027	-	-
_BPRM_ER	Bit	F00028	Basic parameter error	Check basic parameters to see if they are abnormal
_IOPRM_ER	Bit	F00029	I/O parameter error	Check the I / O parameter to see if it is abnormal
_SPPRM_ER	Bit	F0002A	Special module parameter error	Check special module parameter to see if they are abnormal
_CPPRM_ER	Bit	F0002B	Parameter error in communication module	Check communication module parameter to see if they are abnormal
_PGM_ER	Bit	F0002C	Program error	Check user program to see if there is any problem
_CODE_ER	Bit	F0002D	Program Code error	Occurs when an uninterpretable command is encountered while executing a user program
_SWDT_ER	Bit	F0002E	System watchdog error	Occurs when the system watchdog is exceeded
_BASE_POWER_ER	Bit	F0002F	Power error	Occurs when there is an error in the base power supply
_WDT_ER	Bit	F00030	Scan watchdog	Occurs when the scan time of the program exceeds the Scan Watchdog Time specified by the parameter.
-	-	F00031 F0003F	-	-

\_CNF\_WAR

Collectively displays warning flag related to continue operation(DWORD, F004~F005)

Variable	Type	Device	Function	Description
_RTC_ER	Bit	F00040	Abnormal RTC data	In case of abnormal data of RTC
_DBCK_ER	Bit	F00041	Data back-up error	Cold restart is performed because normal (hot or warm restart) program modification is impossible due to abnormal backup data memory. A flag indicating this can be used for the initialization program and will be reset automatically upon completion of the initialization program.
_HBCK_ER	Bit	F00042	Hot restart error	Indicates that hot restart is not possible
_ABSD_ER	Bit	F00043	Stop abnormal operation	It occurs when the program stops during operation for reasons such as power cut off during program execution, and continuous operation is not performed due to the preservation data synchronized in scan unit when power is turned on again. Available in the initialization program and will be reset automatically upon completion of the initialization program.
_TASK_ER	Bit	F00044	Task collision	When a user program runs, if the same task is requested repeatedly, the task shows a conflict.
_BAT_ER	Bit	F00045	Battery error	Detects and displays when the battery voltage required for user program and data memory backup is less than the standard.
_ANNUM_ER	Bit	F00046	Minor error detection in external device	When a warning message of an external device is detected by the user program and recorded in ANC_WB [n], fault detection is displayed.
_LOG_FULL	Bit	F00047	Warning: Log memory full	Indicates that there is no log memory save area of PLC.
_HS_WAR1	Bit	F00048	HS parameter 1 error	This flag is displayed when HS link operation is impossible by checking the error of each HS link parameter when HS link setting (Enable). Reset when HS link is disabled
_HS_WAR2	Bit	F00049	HS parameter 2 error	
_HS_WAR3	Bit	F0004A	HS parameter 3 error	
_HS_WAR4	Bit	F0004B	HS parameter 4 error	
_HS_WAR5	Bit	F0004C	HS parameter 5 error	
_HS_WAR6	Bit	F0004D	HS parameter 6 error	
_HS_WAR7	Bit	F0004E	HS parameter 7 error	
_HS_WAR8	Bit	F0004F	HS parameter 8 error	
_HS_WAR9	Bit	F00050	HS parameter 9 error	
_HS_WAR10	Bit	F00051	HS parameter 10 error	
_HS_WAR11	Bit	F00052	HS parameter 11 error	
_HS_WAR12	Bit	F00053	HS parameter 12 error	
_P2P_WAR1	Bit	F00054	P2P parameter 1 error	This flag is displayed when P2P operation is impossible by checking the error of each P2P parameter when P2P setting is enabled. Reset when HS P2P is disabled
_P2P_WAR2	Bit	F00055	P2P parameter 2 error	
_P2P_WAR3	Bit	F00056	P2P parameter 3 error	
_P2P_WAR4	Bit	F00057	P2P parameter 4 error	
_P2P_WAR5	Bit	F00058	P2P parameter 5 error	
_P2P_WAR6	Bit	F00059	P2P parameter 6 error	
_P2P_WAR7	-	F0005A	P2P parameter 7 error	
_P2P_WAR8	-	F0005B	P2P parameter 8 error	
_Constant_ER	-	F0005C	Fixed period error	If the scan time is longer than the fixed period, it will be 'ON'.
-	-	F0005D ~F0005F	-	-

7.1.3 Server operation

(1) System configuration

System where Ethernet module communicates with HMI as XGT server

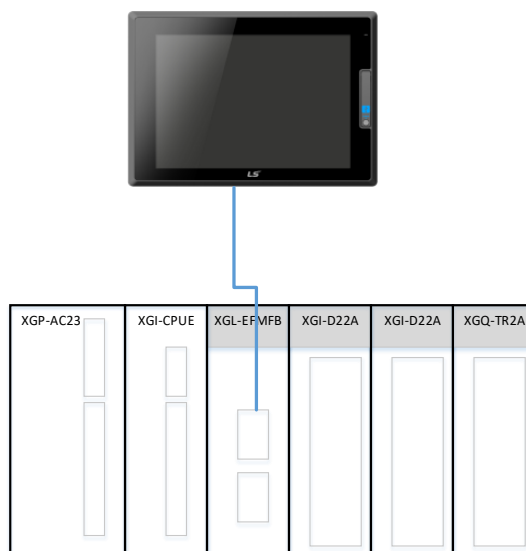

To communicate using server service, you must set server mode before downloading. (If not set, XGT server) Dedicated connection number in basic parameter means the number of channels (HMI connection) connected by XGT server. (However, up to 64 blocks per TCP server port is available in V6.0 and above. Therefore, the number of dedicated communication channels can be changed by changing the number of server connections in the frame editor.

(2) Program procedures

Connect to PLC and set as below.

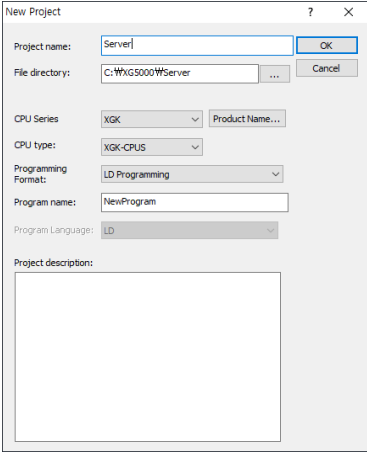
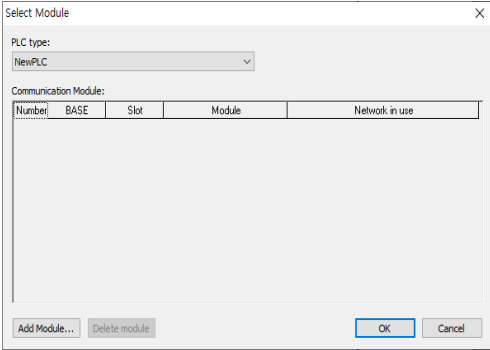
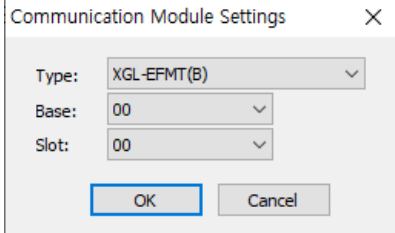
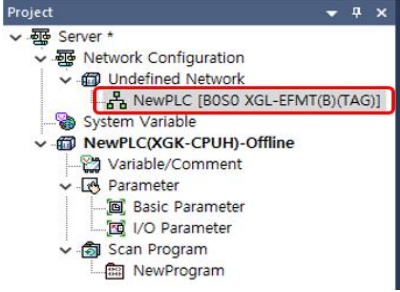
Sequence	Setting process	Setting method
1	Create new project	<p>1) [Project]→Open [New Project] and enter the project name, CPU series, CPU type, programming type, and program name.</p> 
2	Add Undefined network	<p>1) Select [Undefined Network]→[Add item]→ [Communication module].                  2) In the [Select Module] window, click "Add module".</p>  <p>1) Set Type, Base and Slot in Communication module settings. Then select the OK button in the [Communication module setting] window to complete the module setting.</p> 
3	Undefined Network setting	<p>Double-click the communication module in the [Project] window.</p> 

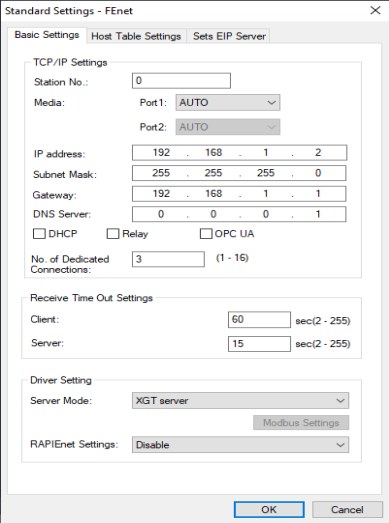
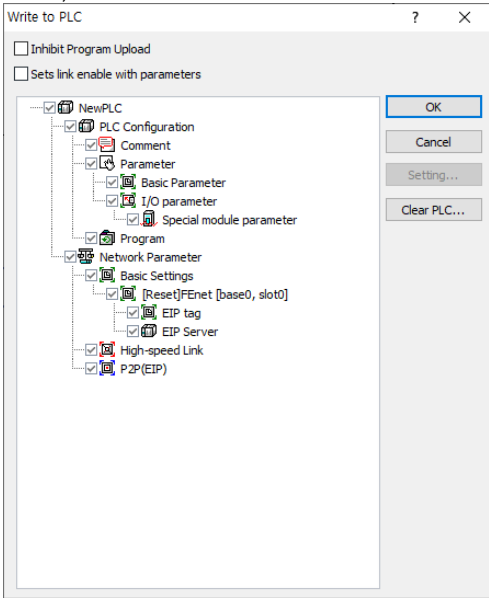
Sequence	Setting process	Setting method
3	Undefined Network setting	<p>Set TCP / IP Settings, Receive time out Settings, and Driver settings on the [Standard Settings] tab.</p> <p>1) Set Station No.: 0 and IP address</p> 
4	Program download	<p>In the [Online]→[Write] window ,Click ok.</p> 

## 7.2 Modbus Server

It is used when another device or upper PC (HMI) operates as Modbus master.

### 7.2.1 Overview

The Modbus TCP/IP protocol is the function to read and write data using the function code. The Modbus TCP/IP frame consists of MAC, Header, TCP Header and Modbus ADU for the Ethernet communication.

- ADU: Application data unit
- PDU: Protocol data unit
- MBAP: Modbus application protocol

#### (1) Frame structure

##### 1) Modbus TCP/ IP server frame structure using Ethernet

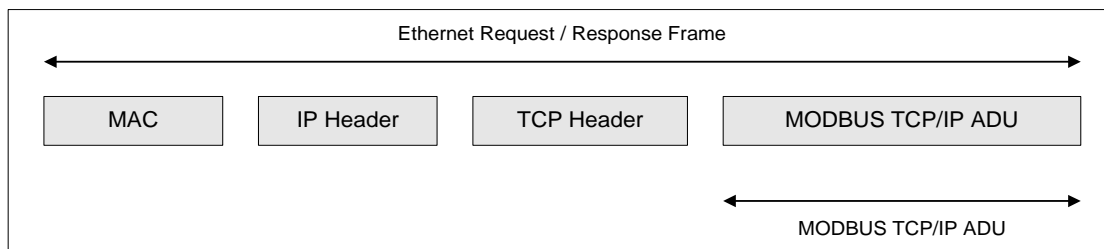

##### 2) Modbus TCP/IP server frame structure

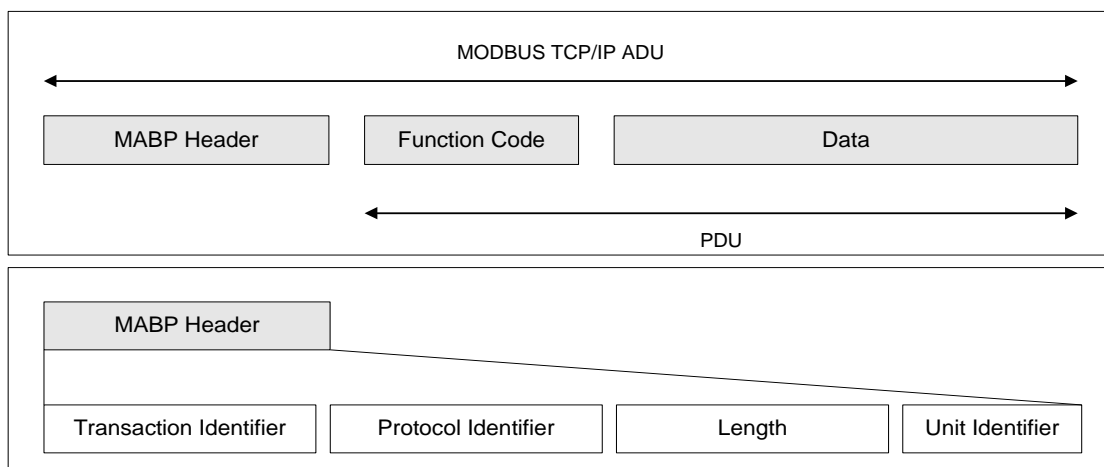

3) MBAP header structure

Classification	Size	Description	Client	Server
Transaction identifier (Transaction Identifier)	2 Byte	Classification of MODBUS request/response process	Initialize on client	Reply by copying in response from server
Protocol Identifier (Protocol Identifier)	2 Byte	0 = MODBUS protocol	Initialize on client	Copy from request frame in response from server
Length	2 Byte	Frame size from unit identifier to data	Create from client	Create from server (When responding)
Unit identifier (Unit Identifier)	1 Byte	Classification of units connected to the serial line	Initialize on client	Copy from request frame in response from server

4) Available function codes

Classification of function code	Function	Modbus function	Response size
Function Code 01 (h01)	Read output bit	Read Coils	2000 Coils
Function Code 02 (h02)	Read input bit	Read Discrete Inputs	2000 Coils
Function Code 03 (h03)	Read output word	Read Holding Registers	125 Registers
Function Code 04 (h04)	Read input word	Read Input Register	125 Registers
Function Code 05 (h05)	Write output bit	Write single Coil	1 Coil
Function Code 06 (h06)	Write output word	Write single Registers	1 Register
Function Code 15 (h0F)	Write output bit continuously	Write Multiple Coils	1968 Coils
Function Code 16 (h10)	Write output word continuously	Write Multiple Registers	123 Registers

7.2.2 Server operation

(1) Program procedures

Connect to PLC and set as below.

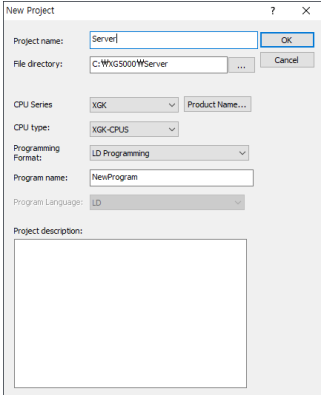
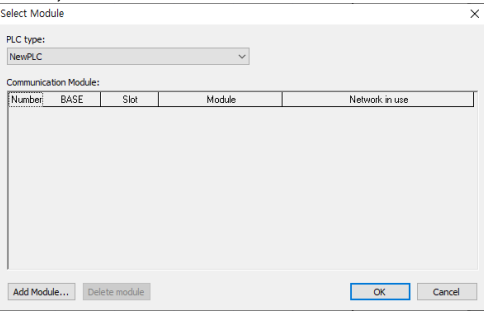
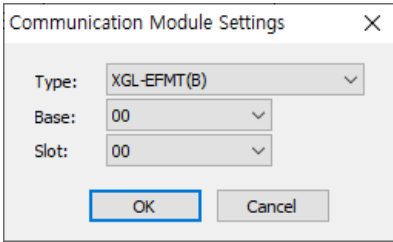
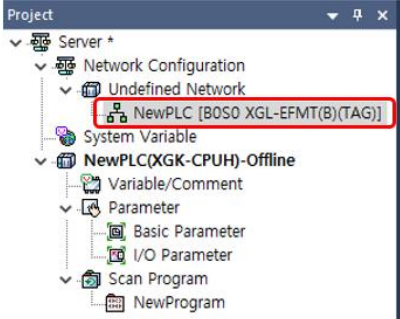
Sequence	Setting process	Setting method
1	Create new project	<p>1) [Project]→Open [New Project] and enter the project name, CPU series, CPU type, programming type, and program name.</p> 
2	Add Undefined network	<p>1) Select [Undefined Network]→[Add item]→ [Communication module].                  2) In the [Select Module] window, click “Add module”.</p>  <p>1) Set Type, Base and Slot in Communication module settings. After that, select OK button in [Communication module selection] and module setting is completed.</p> 
3	Standard settings	<p>Double-click the communication module in the [Project] window.</p> 

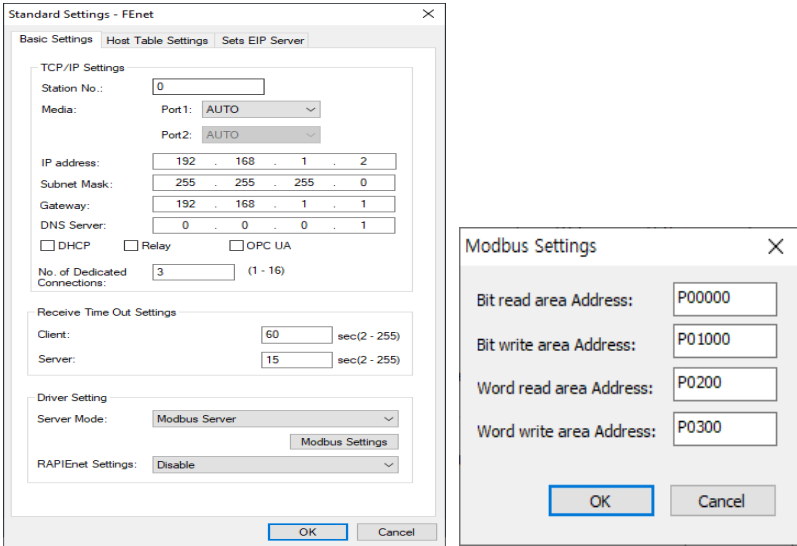
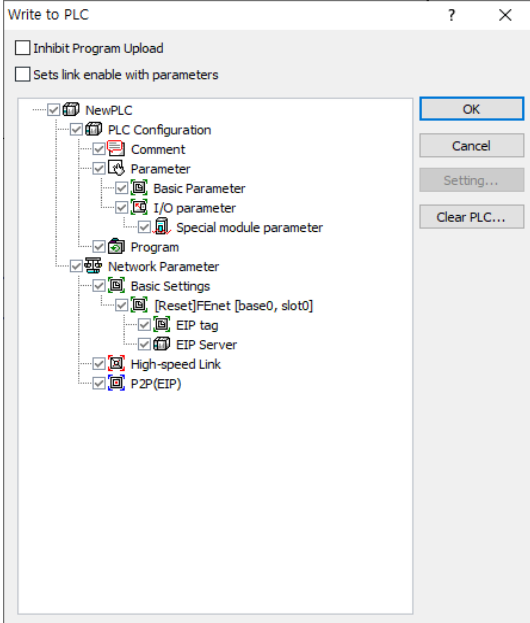
Sequence	Setting process	Setting method
4	Undefined Network setting	<p>Set TCP / IP Settings, Receive time out Settings, and Driver settings on the [Standard Settings] tab.</p> <ol style="list-style-type: none"> <li>1) Set Station No.: 0 and IP address</li> <li>2) Click Modbus setting and input each device</li> </ol> 
5	Program download	<p>In the [Online]→[Write] window ,Click ok.</p> 

### 7.3 EtherNet / IP server

#### 7.3.1 Overview

EtherNet/IP communication methods are divided into explicit messaging connections and implicit (I/O data) connections. An explicit messaging connection is established to execute request-response transactions between two nodes, distinguished by a client-server model. Unconnected Message Manager (UCMM) communication and Class 3 correspond to explicit messaging connections. An implicit connection is established to periodically exchange I/O data, and multicast transmission is possible with a producer-consumer model. Class 1 corresponds to implicit connection.

The producer is set to a periodic target, the consumer is set to a periodic connection, and the UCMM client is set to an acyclic connection mode. The UCMM server and Class 3 server must download the EIP tag, and there are no other communication parameter settings.

The periodic connection is similar to the high-speed link of the existing XGT communication service and is mainly used to transmit and receive data periodically. Non-periodic connection is a communication method mainly used when a specific event occurs.

EtherNet / IP communication function provided by Ethernet module (FEnet) is as follows.

(1) EtherNet / IP(EIP) target/server functions

It provides tag communication function of EIP periodic target function.

It provides tag communication function of EIP Non-periodic server function.

(2) EIP client function

1) EIP periodic connection

- provides EIP periodic connection functionality.
- EIP's periodic connection settings are integrated into the smart expansion service function.

2) EIP Non-periodic connection

- Provides EIP Non-periodic connection functionality.
- EIP's Non-periodic connection settings are integrated into the smart expansion service function.

(3) Smart extension service can connect up to 63 communication devices.

**Notes**

- (1) OS ver V8.0 or higher of XGL-EFMxB support EtherNet / IP communication.
- (2) In OS ver V8.1 of XGL-EFMxB, only one port can be received when setting multicast in the periodic client. Note) Refer to V8.1 Multicast support port guide)
- (3) In OS ver V8.3 higher of XGL-EFMxB, only all port can be received when setting multicast in the periodic connection.

Note) V8.1 Multicast Support Port Guide

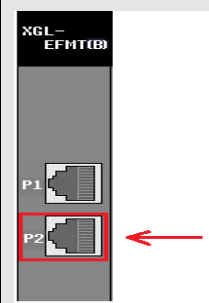
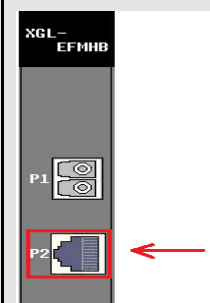
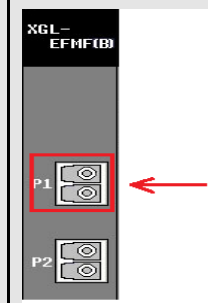
XGL-EFMTB Port 2(lower port)	XGL-EFMHB Port 2(lower port)	XGL-EFMFB Port 1(Upper port)
		

## (4) Periodic communication (Implicit) method

Implicit Message provided by periodic communication means implicit (implicit) message and contains minimum header information except the data on the frame. As a result, the frame itself is a message that does not know what the data means. This means less header information, which simplifies the process of interpreting frames, enabling faster data processing. In EtherNet / IP, a connection is established between the originator and target as parameters for data transfer. An originator is an object that receives and uses the data received after request a connection. The target receives a connection request and Transmission Cycle data desired by the originator in the requested packet interval (RPI) and the desired method (Unicast / Multicast). Therefore, the originator sets up the Consumed Tag and the target sets up the Produced Tag.

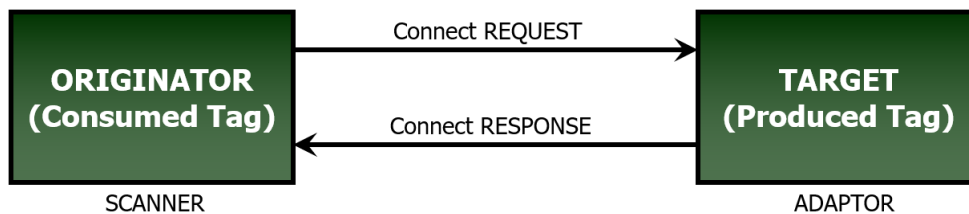
**Notes**

An Originator also generates data to target. Depending on the type, the target can set the timeout with the data cycle given by the originator and output to the target module with the data given by the originator.

## (5) Non-periodic communication (Explicit) method

Explicit Message, which is provided by non-periodic communication, is an explicit meaning that a message contains all the information that can be interpreted in the data frame. Therefore, again if it takes some time to analyze the frame, if the desired message is sent without parameter setting process, the server interprets the frame and sends the response. Mainly monitoring data is used as non-period data rather than control data.

7.3.2 Operation Sequence

(1) EIP periodic target operation sequence

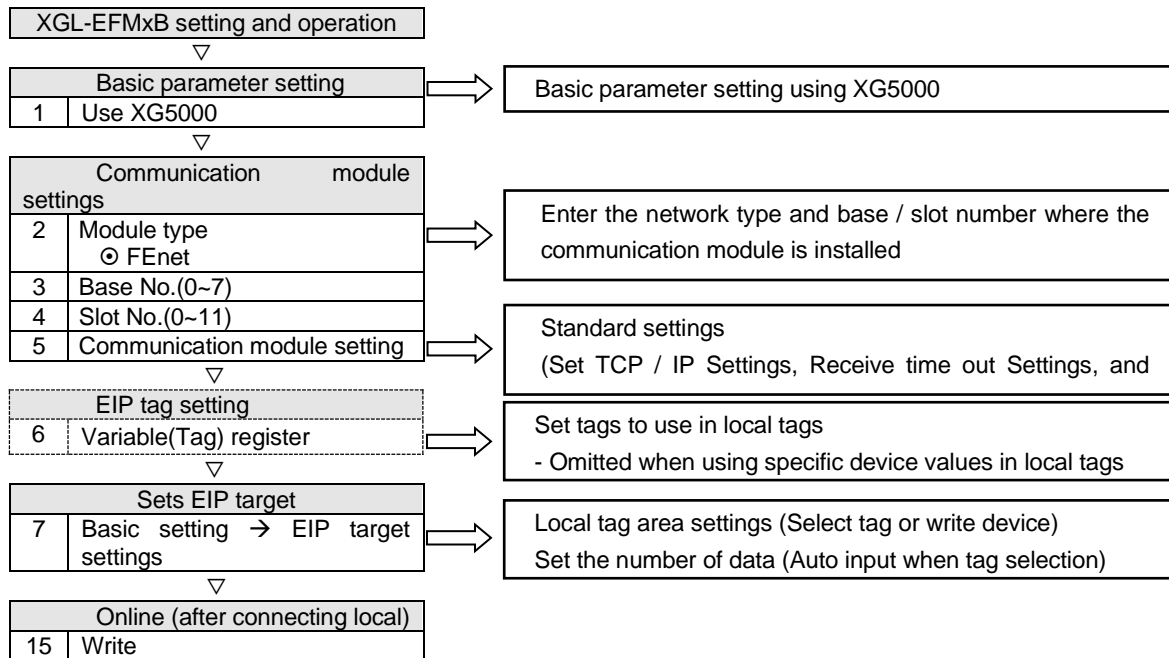

(2) EIP Non-periodic server operation sequence

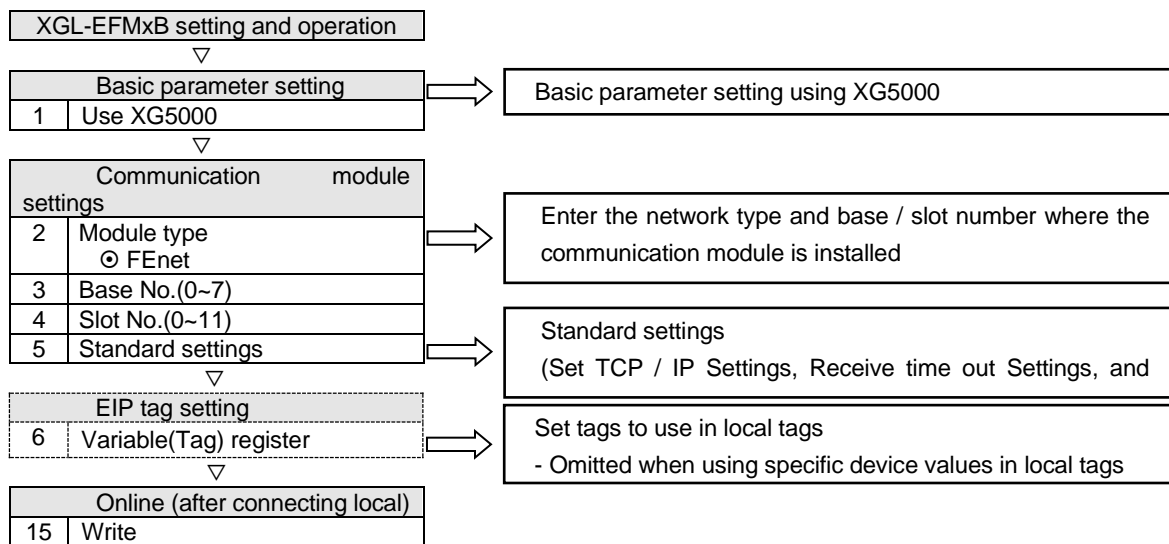

7.3.3Parameter setting

The Ethernet module is a Smart extension service that provides EtherNet/IP connection functions. Describes how to set parameters for EtherNet / IP connection.

(1) Basic settings

Smart Extension service operates according to the Basic Settings of Ethernet (FEnet). The following describes the Basic Settings parameters for the Smart extension service.

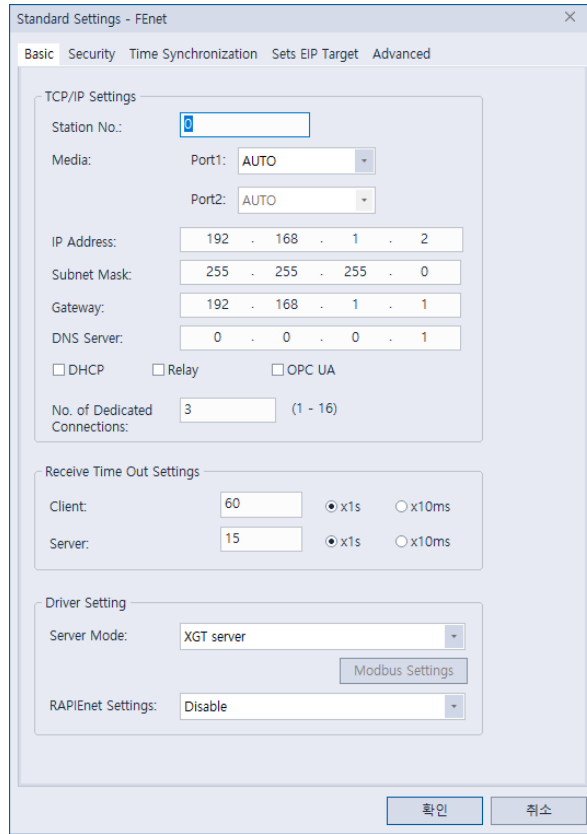

1) Station No

Station number is used as station number of Ethernet module when using RAPIEnet protocol communication with communication device. Station number is not used when setting EtherNet/IP.

2) RAPIEnet setting

The operation varies depending on the RAPIEnet setting in the driver setting item of the Standard Settings.

RAPIEnet setting	Smart extension service operation
Disable	Only the EtherNet / IP protocol can be used for the smart extension service.
RAPIEnet v1	Only RAPIEnet v1 protocol is available. (Smart extension service not available)
RAPIEnet v2	Only the RAPIEnet and EtherNet / IP protocol can be used for the Smart extension service.

7.3.4 Client setting

(1) Adding Smart Extension

- 1) Click the [Project] tab on the left project window and select by right clicking on the communication module item on the tree.

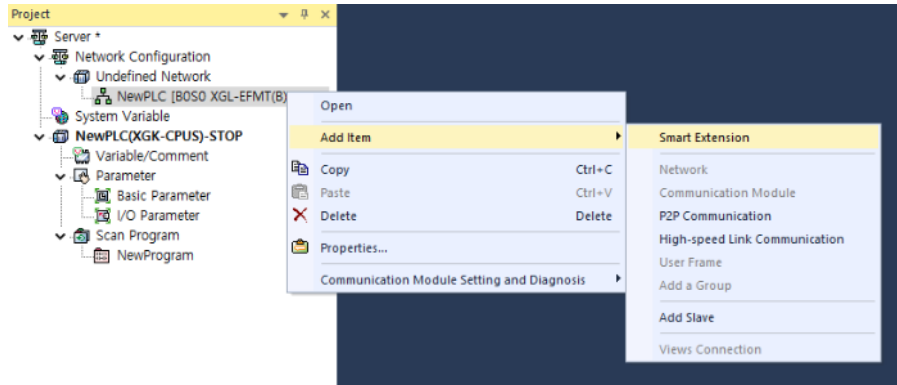

- 1) When using the Smart Extension window to set up the Smart Extension Service, select "Next" in the Smart Extension [Overview] window.

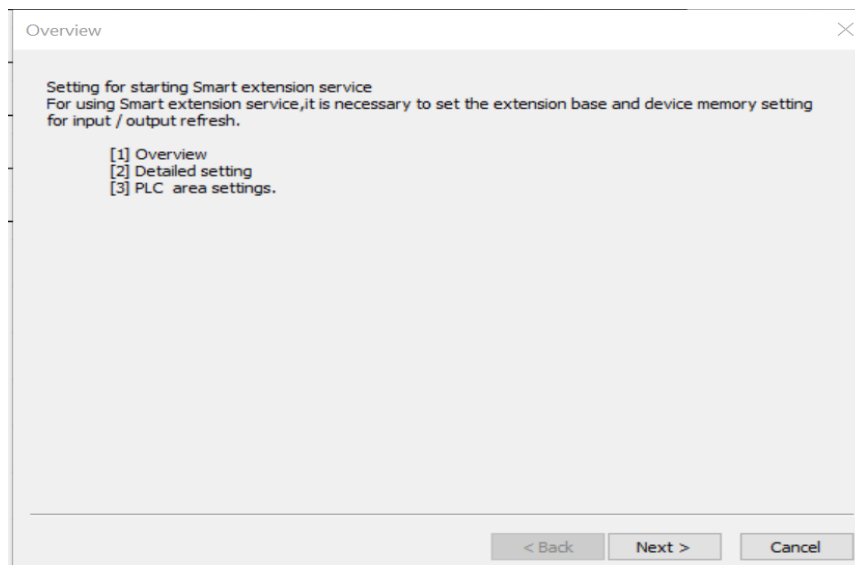

- 2) Smart extension service setting such as communication device adding and setting and PLC area setting can be performed. However, I / O parameter setting should be done separately during Communication device setting. If you select "Next" in the smart extension overview window, the [Details] window appears. If you do not want to add the Smart Extension service without using the Smart Extension window, simply select "Cancel" in the [Overview] window of the Smart Extension window to register the Smart Extension service.

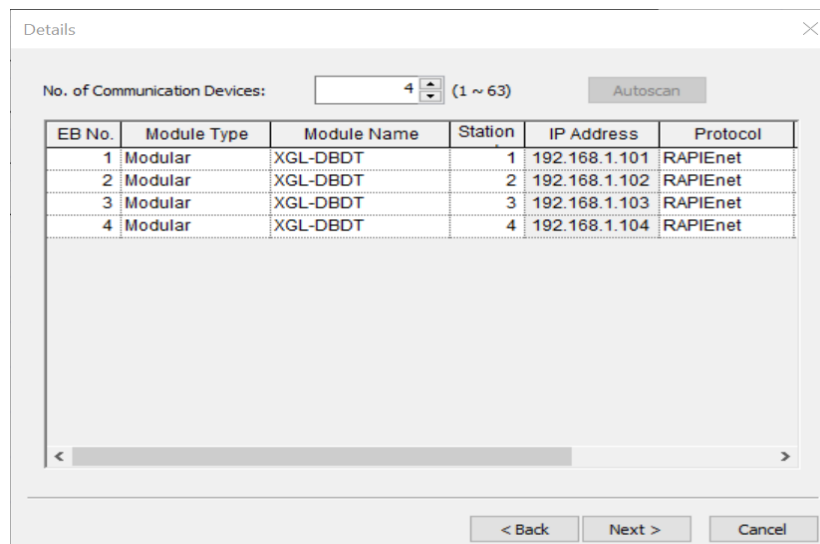

3) After setting each item in [Details] or performing "Autoscan", select the following. In order to proceed with "Auto Scan", it must be in [Online]→[Connect].

Item	Contents										
No. of Communication Devices	Set the number of Communication devices to be added to the Smart extension service.										
Auto scan	Add connected Communication devices and specify connection information automatically. - Only available online.										
EB No.	Specifies the EB number of the communication device to be added. The EB number is the communication device channel number connected to the Ethernet module (master) in the Smart extension service.										
Module type	Specifies the module type of the Communication device to be added. - For the module type, refer to the Communication Device User's Manual.										
Module name	Specifies the module name of the Communication device to be added. - For the module name, refer to the Communication device User's Manual.										
Station No	Specifies the station number of the Communication device to be added. - The station number range is 0 ~ 220. - Setting station number method, refer to the Communication device User's Manual.										
IP Address	Specifies the IP address of the communication device to be added. For the IP setting, refer to the Communication device User's Manual.										
Protocol	Specifies the connecting protocol of the communication device to be added. - The protocol information available between client and communication device between the according to RAPIEnet setting is as follows. <table border="1" style="margin-left: 20px;"> <thead> <tr> <th>RAPIEnet settings for Clients</th> <th>Communication device setting</th> </tr> </thead> <tbody> <tr> <td>Disable</td> <td>EtherNet/IP</td> </tr> <tr> <td rowspan="2">RAPIEnet v1</td> <td>Unavailable Smart Extension</td> </tr> <tr> <td>Unavailable Smart Extension</td> </tr> <tr> <td rowspan="2">RAPIEnet v2</td> <td>EtherNet/IP</td> </tr> <tr> <td>RAPIEnet</td> </tr> </tbody> </table>	RAPIEnet settings for Clients	Communication device setting	Disable	EtherNet/IP	RAPIEnet v1	Unavailable Smart Extension	Unavailable Smart Extension	RAPIEnet v2	EtherNet/IP	RAPIEnet
RAPIEnet settings for Clients	Communication device setting										
Disable	EtherNet/IP										
RAPIEnet v1	Unavailable Smart Extension										
	Unavailable Smart Extension										
RAPIEnet v2	EtherNet/IP										
	RAPIEnet										
Apply	Check the application box of the communication device that will store the connection information.										

4) In [PLC area setting] window, memory setting for 'Input / Output Variable' and 'Enables EB/Slot Diagnostic variable' is available. The address and size are automatically changed according to the communication device added in the advanced detailed settings. (However, the memory area setting counts Smart extension service as the highest priority. An area that overlaps with the memory area used by other services may occur.) When setting are finished, select 'Finish'.

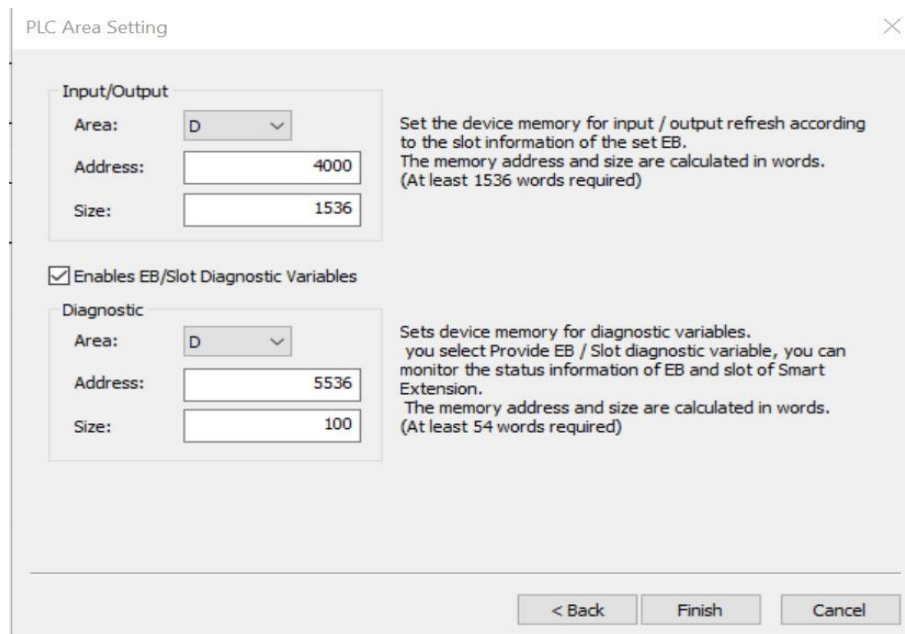

Item	Contents	
Input/Output Variables	Area	Set the memory area of the clients to map the input / output variables of the communication device. - Select between P / M / D areas.
	Address	Set the memory start address of the clients to map the input / output variables of the communication device.
	Size	Set the memory area's size of the clients to map the input / output variables of the communication device. - 384 words per 1 unit of communication device required.
Enables EB/Slot Diagnostic variables	Enable /Disable the use of EB/Slot Diagnostic variables.	
Diagnostic variables	Area	Set the memory area of the client to map the diagnostic variables of the communication device. - Select between P / M / D areas.
	Address	Set the memory start address of the client to map the Diagnostic variables of the Communication device.
	Size	Set the memory area's size of the client to map the Diagnostic variables of the communication device. - The basic diagnostic variable of Smart extension service requires 22 words. - 8 words per 1 unit of communication device are required.

(2) Communication device setting

1) If you double-click EtherNet / IP module among communication devices added under [Project]→[Smart Expansion], you can check [Communication device setting] and [Communication device information] tree.

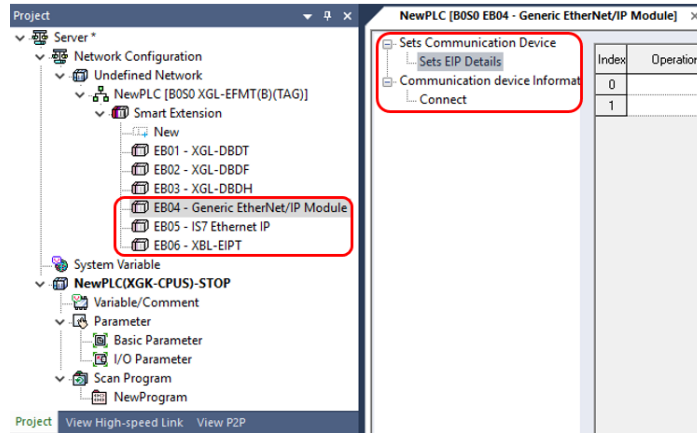

2) In the [Communication device setting] tree, set the connection parameter by setting the block in the [EIP detailed setting] window.



- EIP non-periodic connection setting example

Index	Operation mode	I/O type	Connection type	Function	Parameter	Parameter contents	Conditional flag	Transmission period(ms)	Timeout	Data Type	Local tag	Remote tag	Data count
0	Explicit Client			0. TAG READ			_T1S			WORD	TEST1/D00000	TEST2	1
1													

- EIP periodic connection setting example

Index	Operation mode	I/O type	Connection type	Function	Parameter	Parameter contents	Conditional flag	Transmission period(ms)	Timeout	Data Type	Local tag	Remote tag	Data count
0	Implicit Client	6.Input Only(Tag type)	Multicast		Parameter			20	0. RPI x4	WORD	TEST3/D00002	TEST4	1

Item	Contents
Operation mode	Set the operation mode of the EIP connection. - Select either periodic connection or non-periodic connection.
I/O type	Set I / O type of EIP Period connection. - A list of choices is displayed depending on what is defined in the target's EDS file.
Connection type	Set the connection type with the EIP target. - A list of choices is displayed depending on what is defined in the target 's EDS file.
Function	Sets the functionality of the EIP non-periodic connection. - Setting is not possible in EIP periodic connection.
Parameter	Sets EIP connection parameters Only enabled if the feature is 'read' or 'write' on non-periodic connection.
Parameter contents	The contents set in the parameter are displayed.
Start condition	Sets the start condition of the EIP non-periodic connection. - Setting is not possible in EIP periodic connection
Send cycle	Sets the send cycle of the EIP periodic connection. The minimum value is '20ms'. - Setting is not possible in EIP non-periodic connection
Timeout	Sets the Time-outs of the EIP periodic connection. - Setting is not possible in EIP non-periodic connection
Data type	Sets data type. In EIP periodic connection, they are automatically represented by local tag values.
Local tag	Set the local tag of the EIP connection. - Double-click to select tag or to directly write variable of specific device.
Remote tag	Set the tag of the destination station(EIP target/server) - In addition to the tags, you can write direct variables of a specific device.
The number of data	Set the data number of the EIP tag. - One is a tag (device) written to a Local tag entry. - The size of the tag (device) written in the local tag entry does not matter. - The data size is the number of tags (devices) * data number in 'local tag'.

3) Selecting [Connect] in the [Sets Communication Devices] tree displays the following screen. If the communication device is an EtherNet / IP dedicated module (if it does not have the Smart extension service function), there is only a 'Connection' item in the Communication device information tree.

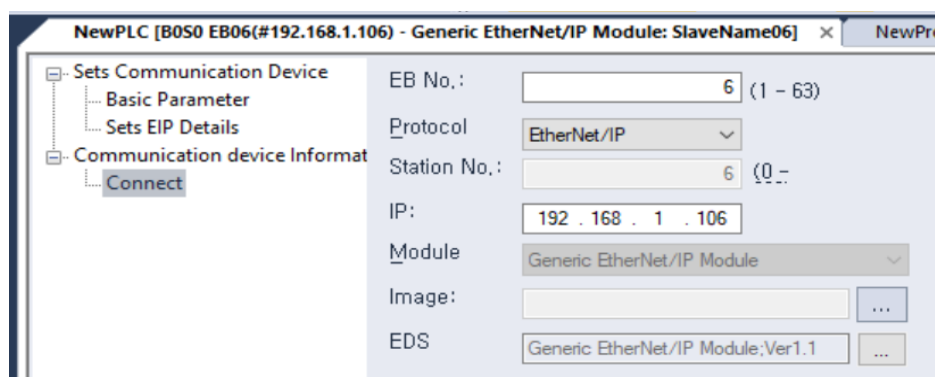

Item	Contents
EB No.	Specify the EB number to be assigned to the communication device.
Protocol type	Specify the protocol type to be used for communication with the communication device. - Only EtherNet / IP can be selected because it is an EtherNet / IP dedicated module.
Station No	Specify Station number set to the Communication device. - Station number setting is impossible because it is an EtherNet / IP dedicated module.
IP	Specify IP address number set to the communication device. Refer to the Communication device user's manual for how to set the communication device's IP address.
Module type	Specifies the module type of the communication device. - Module type is automatically assigned when adding a communication device and cannot be modified.
image	Assigns the image of the communication device. - Use the desired photo file as the image of the communication device. - This image is only used in the 'Configure Communication Device Connection' function.
EDS information	Assigns the EDS information of the communication device. - EDS information is automatically assigned when adding a communication device and cannot be modified.

7.3.5 Server setting

(1) In case of operating as periodic target

1) In the [Project] window, right-click the communication module added under the undefined network and select Open.

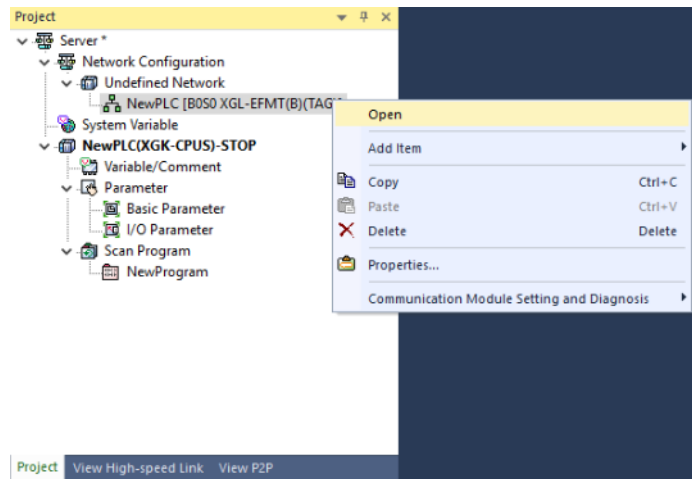

2) Set each item in [Standard settings].

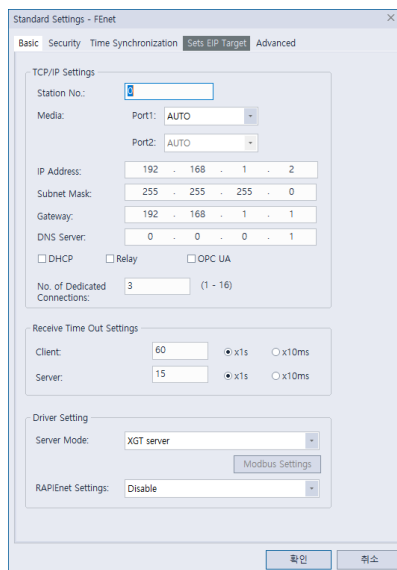

3) In the [Standard settings] window, select the parent Sets EIP Server tab.

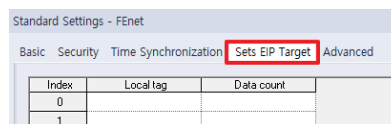

4) In the [Sets EIP Server] window, double-click the area of the local tag. Use device values rather than tags. If you want to use the device value, select the local tag area with the left mouse button once and enter the device value you want to use. In this case, please skip '4).

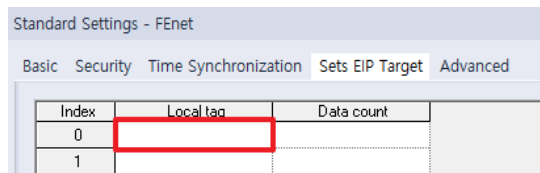

5) In the [Select EtherNet / IP Tag] window, select the tag you want to use as the local tag for the EIP periodic target, then select OK.

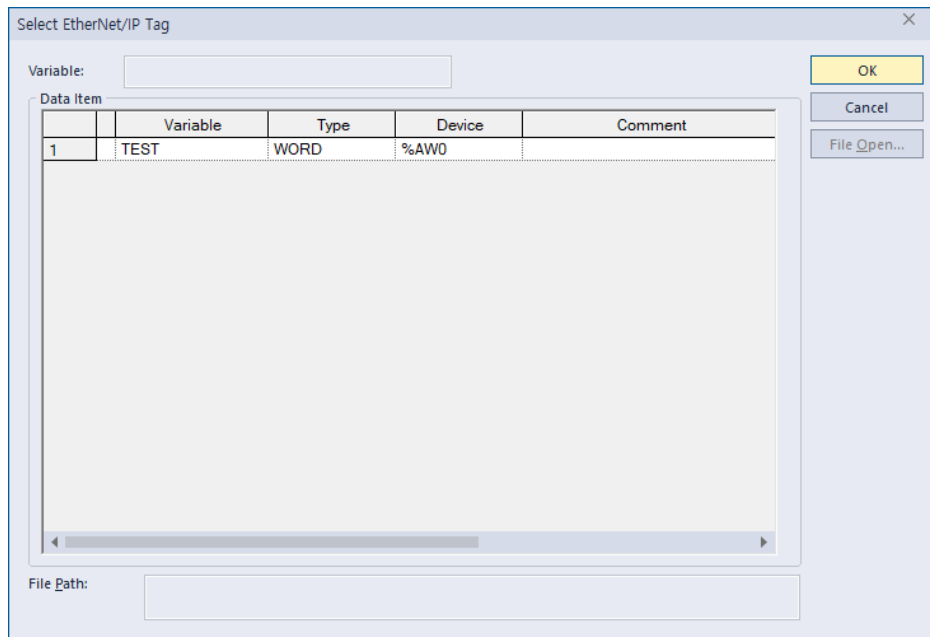

6) If the tag has been added to a local tag in the [Sets EIP target] window, select OK.

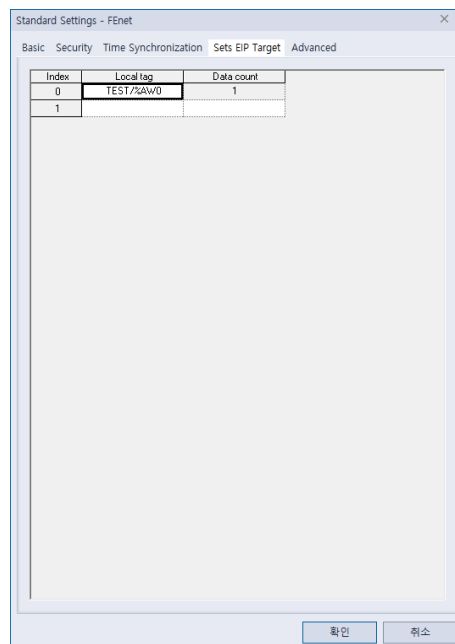

(2) In case of operating as Non-periodic server

When the Ethernet module operates as Non-periodic server, there is no additional parameter setting other than tag registration.

### 7.3.6 Tag register

If an EIP connection uses a tag other than a device for a local tag, the tag must be registered first. The Tag register method is as follows.

(1) Tag setting when using XGK CPU

1) Set tag for EIP communication. Select [Project]→[Setting EtherNet / IP (OPC UA) Variable].

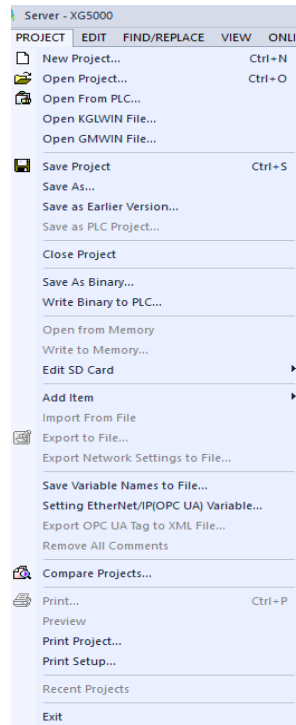

2) In the [Setting EtherNet / IP (OPC UA) Variable] window, select New Variable.

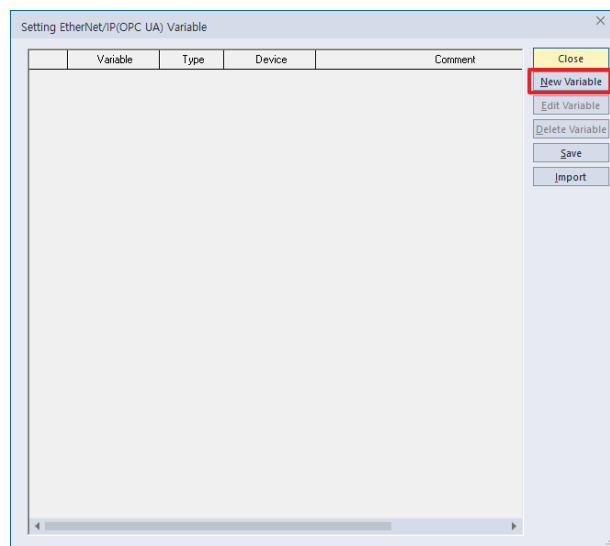

3) "Select 'New Variable', enter and select the variable, data type, device, etc. and select OK.

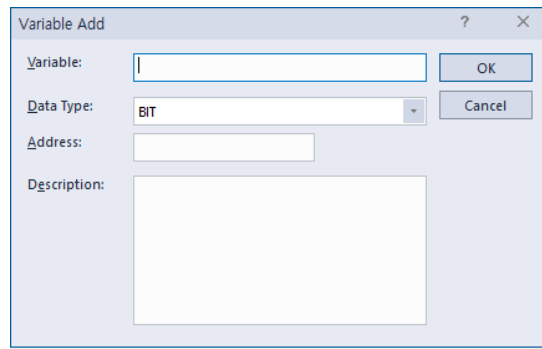

Item	Contents
Variable	Enter the name of the variable (tag) to use
Data type	Select the data type of variable (tag) to use.
Device	Enter the device address with the variable (tag).
Description	Enter a description of the variable (tag). (Enter it if necessary)

4) After confirming that the variable added in the Setting EtherNet / IP (OPC UA) variable window appears normally, select Close.

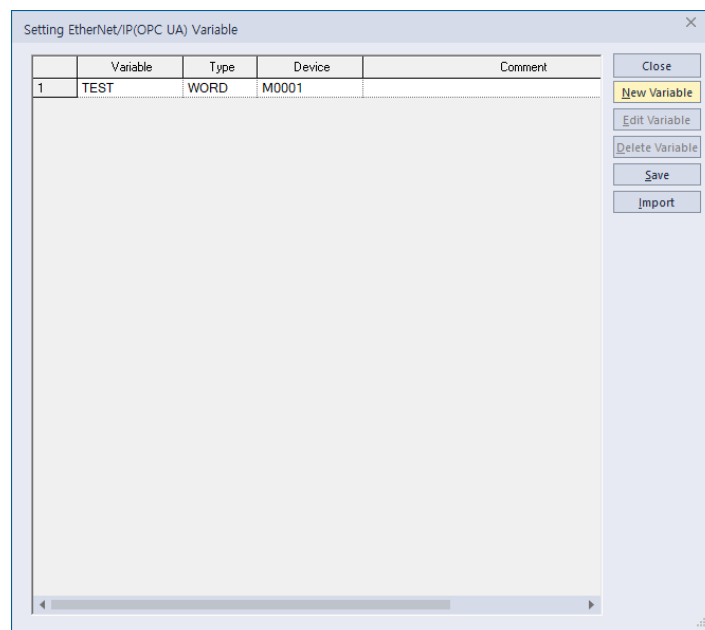

(2) Tag setting when using XGI, XGR CPU

1) Right-click on [Global / Direct Variable] or [Local Variable] in the [Project] window and select Open.

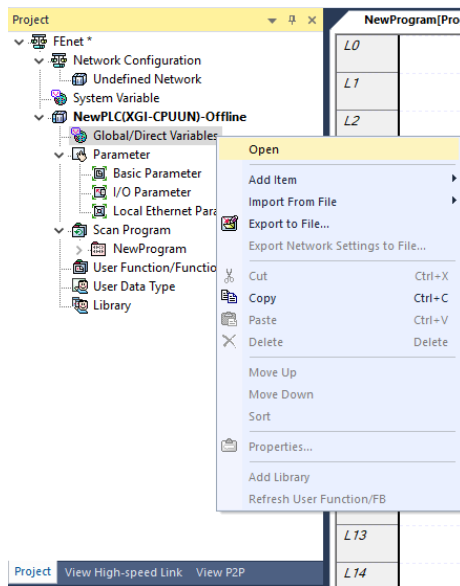

2) Fill in the information of the variable (tag) to be used and check “EIP / OPC UA”.

(For details of global / direct variable and local variable setting, please refer to XGI, XGR CPU manual.)

	Variable Kind	Variable	Type	Address	Initial Value	Retain	Used	EIP/OPC UA	HMI	Motion	Comment
1	VAR_GLOBAL	TEST	WORD			<input type="checkbox"/>	<input checked="" type="checkbox"/>	<input checked="" type="checkbox"/>	<input type="checkbox"/>	<input type="checkbox"/>	

### 7.3.7 Setting Download

Downloading the EIP connection configuration will download it to the CPU module. The download method is as follows.

- (1) On the [Online] tab, select Write

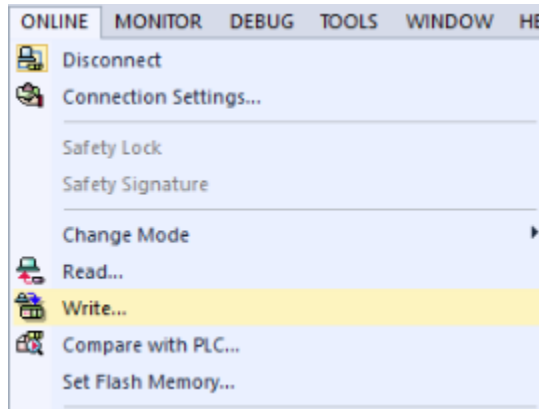

- (2) In the [Write] window, check the check boxes of [Smart Extension Service], [EIP Tag], and [EIP target], and select OK. When downloading the Smart extension service, EIP tag, and EIP target, the module does not need to be reset and the settings are immediately reflected.
- (3) When the module is exchanged using the Module Changing Wizard, the EIP tag and EIP target parameter is not set automatically. Redownload EIP tag and EIP target parameter by using [Online] → [Write] of XG5000.

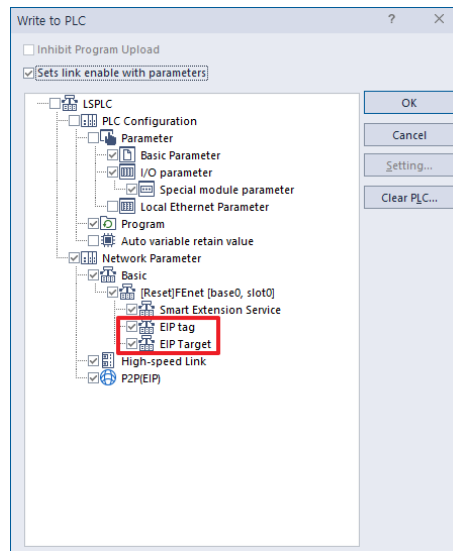

- (4) EIP Service enable

Start EtherNet/IP client operation when Smart Extension Service is enabled on [Online] → [Communication module setting and Diagnosis] → [Service Enable] window. There is no separate service enable process for EIP target. Download EIP settings and start working

7.3.8 EtherNet/IP periodic communication operation example

(1) Operation of EtherNet/IP module (scanner) and Ethernet module (adapter)

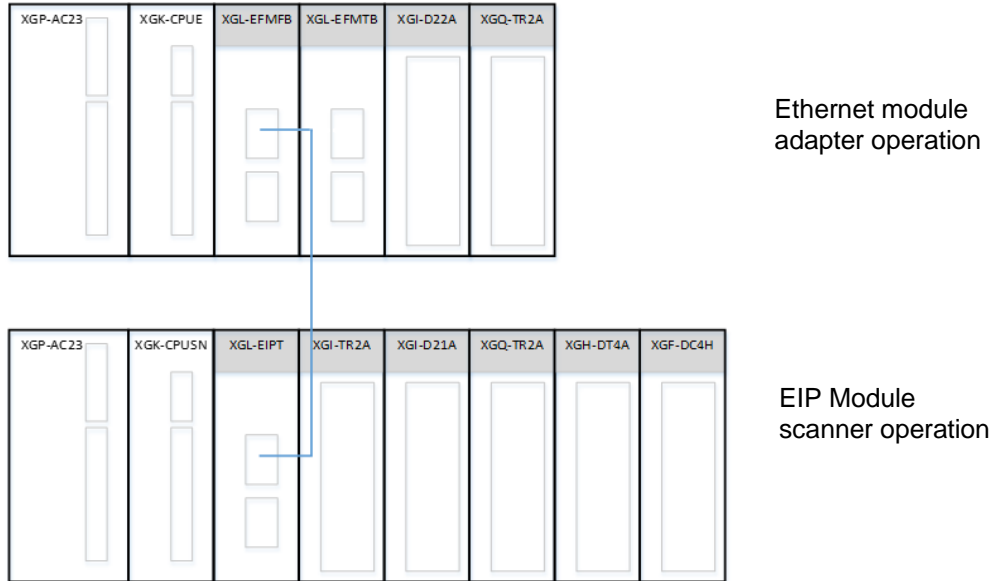

This is an example of connecting the Ethernet module to the EIP target. This is an example of a program that reads the adapter's tag setting data from the scanner at periodic intervals.

Passes tag tttt (D0010) word data from the adapter as scanner tag jjjj (D00100) word data.

1) Scanner setting(XGL-EIPT)

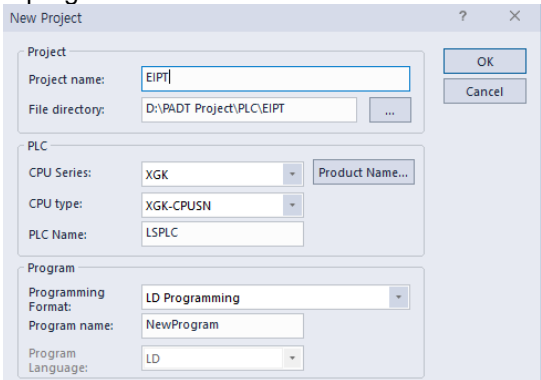
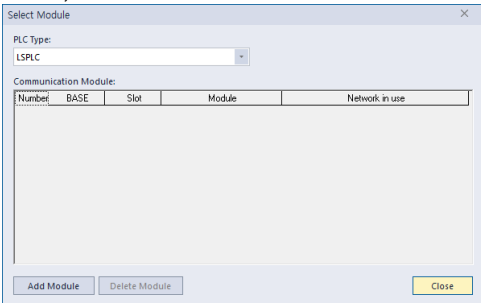
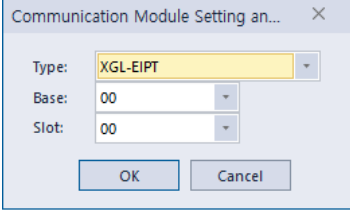
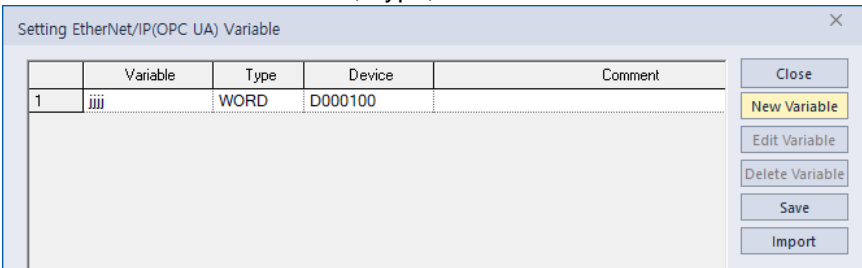
Sequence	Setting process	Setting method																						
1	Create new project	<p>1) [Project]→Open [New Project] and enter the project name, CPU series, CPU type, programming format, and program name.</p> 																						
2	Add Undefined network	<p>1) Select [Undefined Network]→[Add item]→ [Communication module].                  2) In the [Select Module] window, click “Add module”.</p>  <p>1) Set Type, Base and Slot in Communication module settings. After that, select ok button in [Communication module setting and Diagnosis] and module setting is completed.</p> 																						
3	Tag registration	<p>1) XGK CPU                  - Click [Project]→[EtherNet / IP (OPC UA) Tag Settings].                  - Select "New Variable" to add variables, Type, and device.</p>  <p>2) XGI/R CPU                  - Add variables in the [Global / Direct Variables] or [Local Variables] window of the project tree.                  - Check the EIP / OPC UA item.</p> <table border="1" data-bbox="431 1959 1516 2024"> <thead> <tr> <th></th> <th>Variable Kind</th> <th>Variable</th> <th>Type</th> <th>Address</th> <th>Initial Value</th> <th>Retain</th> <th>Used</th> <th>EIP/OPC UA</th> <th>HMI</th> <th>Comment</th> </tr> </thead> <tbody> <tr> <td>1</td> <td>VAR_GLOBAL</td> <td>jjjj</td> <td>WORD</td> <td>%MW100</td> <td></td> <td><input type="checkbox"/></td> <td><input type="checkbox"/></td> <td><input checked="" type="checkbox"/></td> <td><input type="checkbox"/></td> <td></td> </tr> </tbody> </table> <p>* If you use continuous data, create an Array type variable.</p>		Variable Kind	Variable	Type	Address	Initial Value	Retain	Used	EIP/OPC UA	HMI	Comment	1	VAR_GLOBAL	jjjj	WORD	%MW100		<input type="checkbox"/>	<input type="checkbox"/>	<input checked="" type="checkbox"/>	<input type="checkbox"/>	
	Variable Kind	Variable	Type	Address	Initial Value	Retain	Used	EIP/OPC UA	HMI	Comment														
1	VAR_GLOBAL	jjjj	WORD	%MW100		<input type="checkbox"/>	<input type="checkbox"/>	<input checked="" type="checkbox"/>	<input type="checkbox"/>															

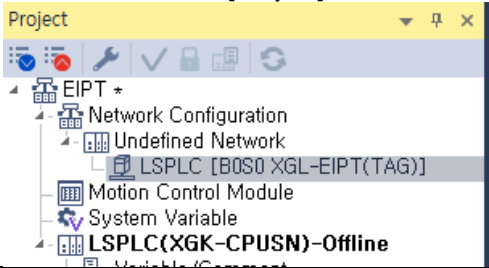
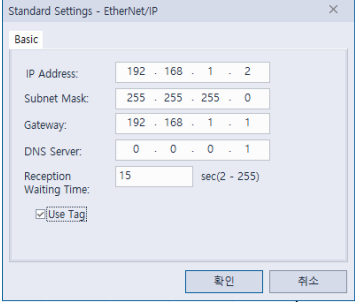
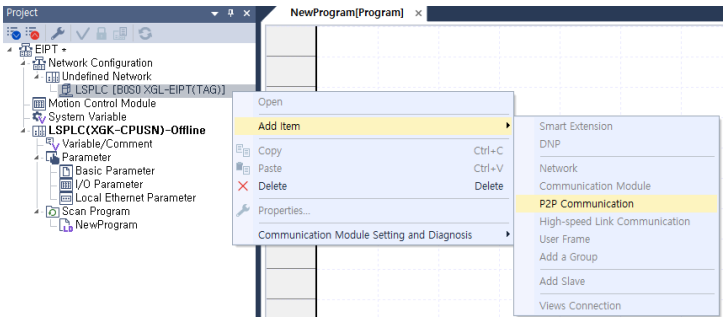
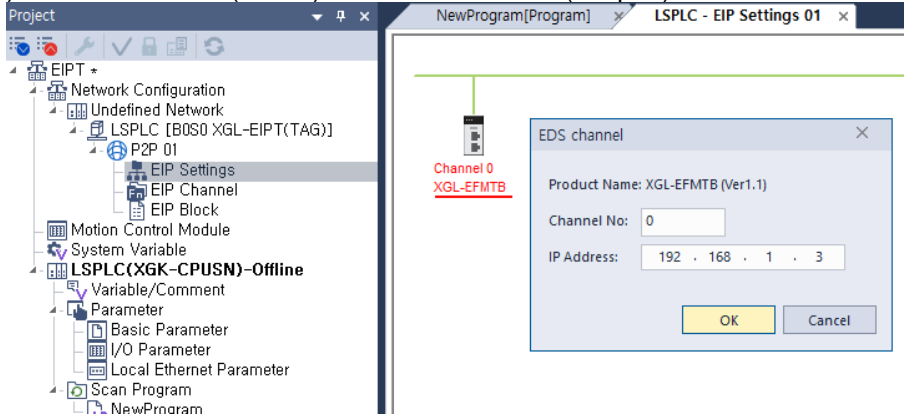
Sequence	Setting process	Setting method
4	Standard settings	<p>Double-click the communication module in the [Project] window.</p>  <p>In the [Standard settings] window, set the IP address, subnet mask, gateway, DNS server, waiting time, and tag usage. Check when using tag information in EIP module.</p> 
5	Service settings	<p>Click [Project]→[Add item]→[P2P Communication]. Select among P2P parameter window No. 1 ~ 8</p>  <ol style="list-style-type: none"> <li>1) Double click EIP settings to display the [EIP settings 01] screen below. Then click [EDS Information] on the right side of XG5000 screen to register EDS information of the external device (XGL-EFMTB) to be connected to EIP.</li> <li>2) If you click the external device to connect in [EDS Information], EDS by version is displayed. Drag the version to the [EIP settings 01] screen to open the [EDS Channel Settings] window.</li> <li>3) Set IP of channel (0 ~ 63) and external device (adapter).</li> </ol> 

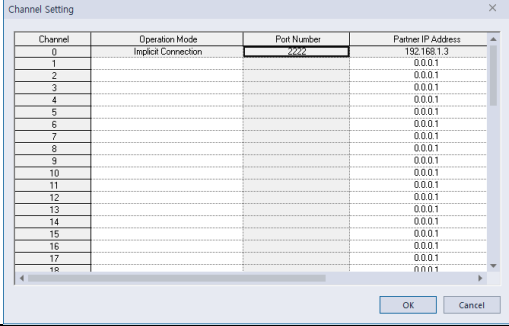
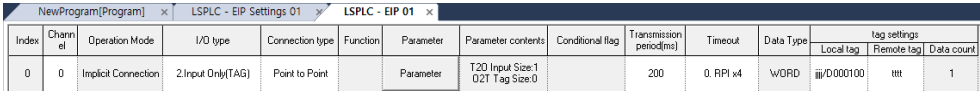
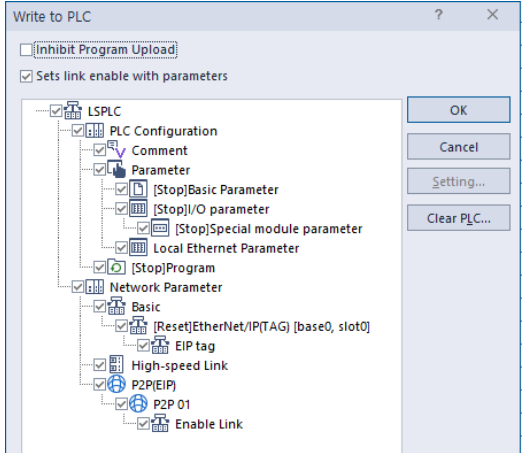
Sequence	Setting process	Setting method
5	Service settings	<p>Double click EIP channel to open [Channel setting] window. Channel 0's operation mode is set as period client as previously set in EIP configuration.</p>  <ol style="list-style-type: none"> <li>1) Double click EIP block to set up block</li> <li>2) Input I / O type, connection type and tag setting in channel 0. (The information below depends on the server's EDS content.) <ul style="list-style-type: none"> <li>- 0. In/Out: read/write</li> <li>- 1. Input Only: Read-only</li> <li>- 2. Input Only(TAG): Tag Read-only</li> </ul> </li> <li>3) Set connection type <ul style="list-style-type: none"> <li>- Choose between Multicast and Point to Point.</li> </ul> </li> <li>4) Parameter <ul style="list-style-type: none"> <li>- Enter the read size. The data type is determined by the registered tag information.</li> </ul> </li> <li>5) Transmission period(ms), Timeout <ul style="list-style-type: none"> <li>- Set the Transmission period and timeout.</li> </ul> </li> <li>6) Tag time setting <ul style="list-style-type: none"> <li>- Local tag: Device (tag) of master to save data read from server. Double click to select from [Select EIP Tag] window or set by directly inputting variable.</li> <li>- Remote tag: The device (tag) of the server you want to read.</li> </ul> </li> </ol> 
6	Program download/ Set link enable	<p>On [Online]→[Write] window, check Basic settings, EIP tag, P2P and Enable link and click OK.</p>  <p>Link enable settings can also be set in [Online]→[Communication module setting and diagnosis]→[Enable Services].</p>

2) Adapter setting(XGL-EFMTB)

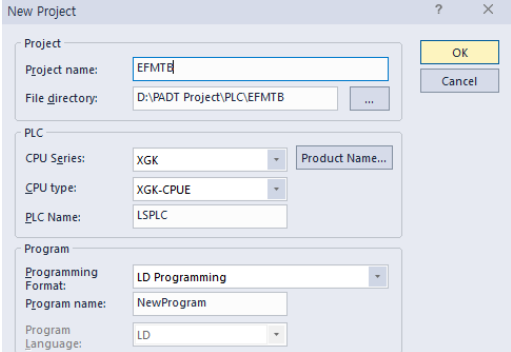
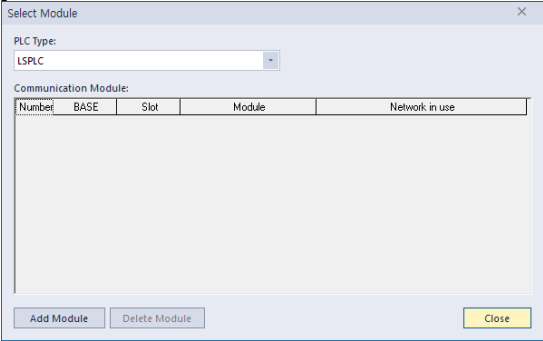
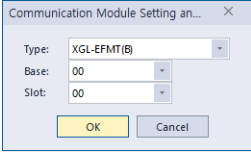
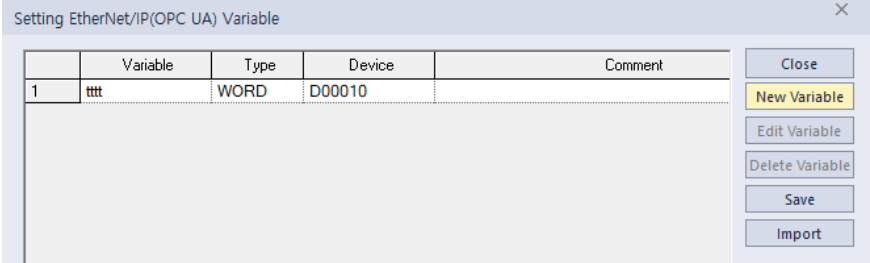
Sequence	Setting process	Setting method																								
1	Create new project	<p>1) [Project]→Open [New Project] and enter the project name, CPU series, CPU type, programming type, and program name.</p> 																								
2	Add Undefined network	<p>1) Select [Undefined Network]→[Add item]→ [Communication module]. 2) In the [Select Module] window, click “Add module”.</p>  <p>1) Set Type, Base and Slot in Communication module settings. After that, select OK button in [Communication module setting] and module setting is completed.</p> 																								
3	Tag registration	<p>1) XGK CPU - Click [Project]→[EtherNet / IP (OPC UA) Tag Settings]. - Select “Add Variable” to add variables, data types, and devices.</p>  <p>2) XGI/R CPU - Add variables in the [Global / Direct Variables] or [Local Variables] window of the project tree. - Check the EIP / OPC UA item.</p> <table border="1" data-bbox="436 1914 1463 1982"> <thead> <tr> <th></th> <th>Variable Kind</th> <th>Variable</th> <th>Type</th> <th>Address</th> <th>Initial Value</th> <th>Retain</th> <th>Used</th> <th>EIP/OPC UA</th> <th>HMI</th> <th>Motion</th> <th>Comment</th> </tr> </thead> <tbody> <tr> <td>1</td> <td>VAR_GLOBAL</td> <td>ttt</td> <td>WORD</td> <td>%MW10</td> <td></td> <td><input type="checkbox"/></td> <td><input type="checkbox"/></td> <td><input checked="" type="checkbox"/></td> <td><input type="checkbox"/></td> <td><input type="checkbox"/></td> <td></td> </tr> </tbody> </table> <p>* If you use continuous data, create an Array type variable.</p>		Variable Kind	Variable	Type	Address	Initial Value	Retain	Used	EIP/OPC UA	HMI	Motion	Comment	1	VAR_GLOBAL	ttt	WORD	%MW10		<input type="checkbox"/>	<input type="checkbox"/>	<input checked="" type="checkbox"/>	<input type="checkbox"/>	<input type="checkbox"/>	
	Variable Kind	Variable	Type	Address	Initial Value	Retain	Used	EIP/OPC UA	HMI	Motion	Comment															
1	VAR_GLOBAL	ttt	WORD	%MW10		<input type="checkbox"/>	<input type="checkbox"/>	<input checked="" type="checkbox"/>	<input type="checkbox"/>	<input type="checkbox"/>																

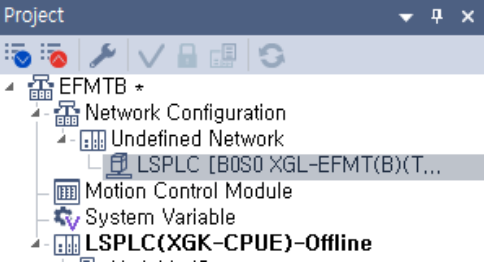
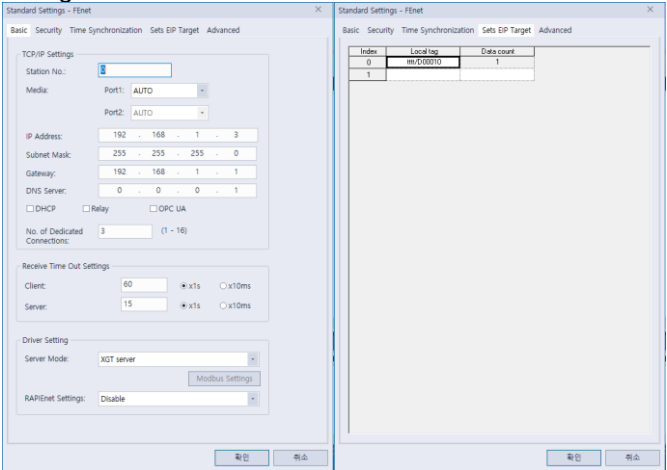
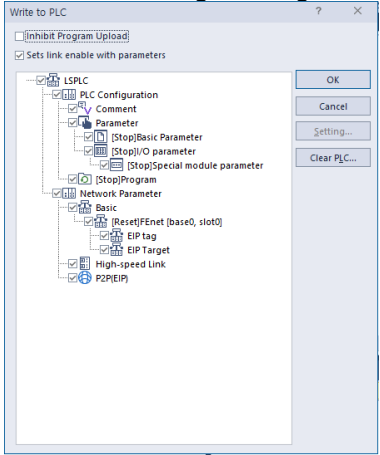
Sequence	Setting process	Setting method
4	Standard settings	<p>Double-click the communication module in the [Project] window.</p> 
		<p>After setting IP address, subnet mask, gateway and DNS server in the [Standard settings] window, register the tag to be used in the sets EIP server.</p> 
5	Program download	<p>In [Online]→[Write] window, check Basic setting, EIP tag, P2P and EIP Target and click OK</p> 

(2) Operation of Ethernet module (scanner) and EtherNet/IP module (adapter)

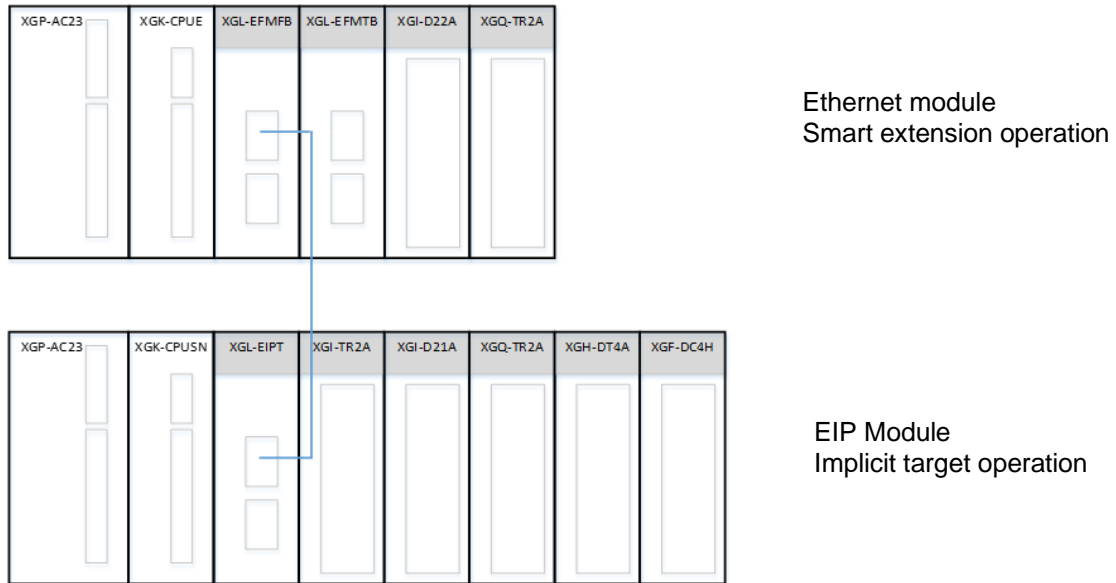

This is a program example that reads tag data of XGL-EIPT connected to periodic target by Smart extension service of Ethernet module.

Delivers tag jjjj (D00100) word data from the adapter as scanner's tag tttt (D00010) word data.

1) Scanner setting(XGL-EFMTB)

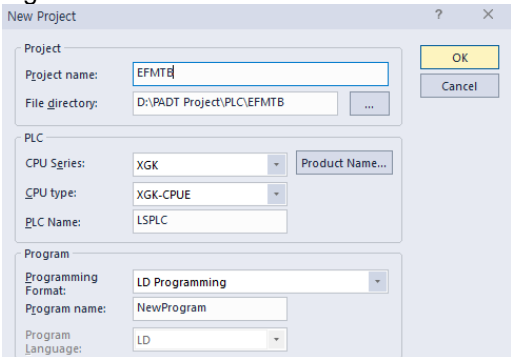
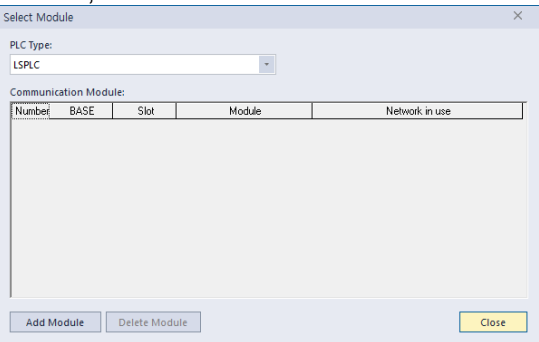
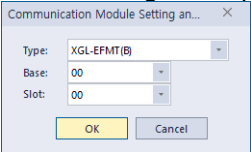
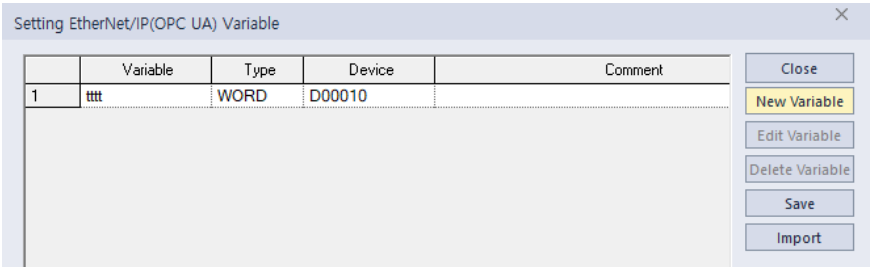
Sequence	Setting process	Setting method																								
1	Create new project	<p>1) [Project]→Open [New Project] and enter the project name, CPU series, CPU type, programming type, and program name.</p> 																								
2	Add Undefined network	<p>1) Select [Undefined Network]→[Add item]→ [Communication module]. 2) In the [Select Module] window, click “Add module”.</p>  <p>1) Set Type, Base and Slot in Communication module settings. After that, select OK button in [Communication module setting] and module setting is completed.</p> 																								
3	Tag registration	<p>1) XGK CPU - Click [Project]→[EtherNet / IP (OPC UA) Tag Settings]. - Select “Add Variable” to add variables, data types, and devices.</p>  <p>2) XGI/R CPU - Add variables in the [Global / Direct Variables] or [Local Variables] window of the project tree. - Check the EIP / OPC UA item.</p> <table border="1" data-bbox="436 1880 1463 1954"> <thead> <tr> <th></th> <th>Variable Kind</th> <th>Variable</th> <th>Type</th> <th>Address</th> <th>Initial Value</th> <th>Retain</th> <th>Used</th> <th>EIP/OPC UA</th> <th>HMI</th> <th>Motion</th> <th>Comment</th> </tr> </thead> <tbody> <tr> <td>1</td> <td>VAR_GLOBAL</td> <td>tttt</td> <td>WORD</td> <td>%MW10</td> <td></td> <td><input type="checkbox"/></td> <td><input type="checkbox"/></td> <td><input checked="" type="checkbox"/></td> <td><input type="checkbox"/></td> <td><input type="checkbox"/></td> <td></td> </tr> </tbody> </table> <p>* If you use continuous data, create an Array type variable.</p>		Variable Kind	Variable	Type	Address	Initial Value	Retain	Used	EIP/OPC UA	HMI	Motion	Comment	1	VAR_GLOBAL	tttt	WORD	%MW10		<input type="checkbox"/>	<input type="checkbox"/>	<input checked="" type="checkbox"/>	<input type="checkbox"/>	<input type="checkbox"/>	
	Variable Kind	Variable	Type	Address	Initial Value	Retain	Used	EIP/OPC UA	HMI	Motion	Comment															
1	VAR_GLOBAL	tttt	WORD	%MW10		<input type="checkbox"/>	<input type="checkbox"/>	<input checked="" type="checkbox"/>	<input type="checkbox"/>	<input type="checkbox"/>																

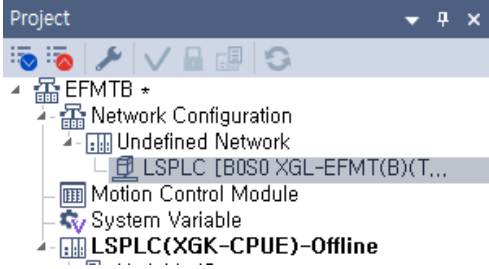
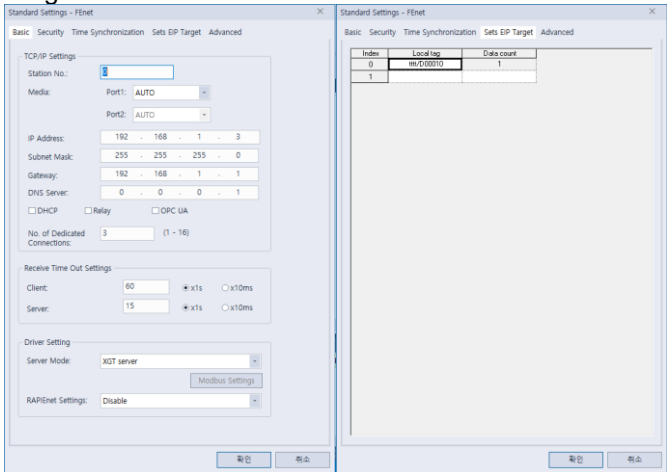
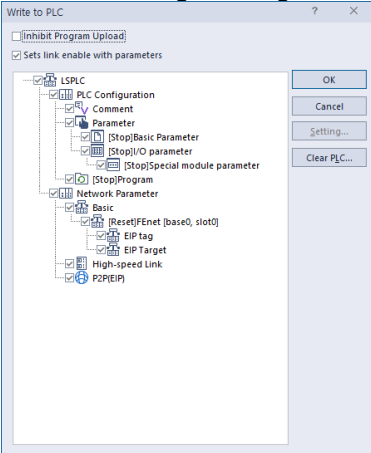
Sequence	Setting process	Setting method
4	Standard settings	<p>Double-click the communication module in the [Project] window.</p> 
		<p>After setting IP address, subnet mask, gateway and DNS server in the [Standard settings] window, register the tag to be used in the sets EIP server.</p> 
5	Program download	<p>In [Online]→[Write] window, check Basic setting, EIP tag, P2P and EIP Target and click OK</p> 

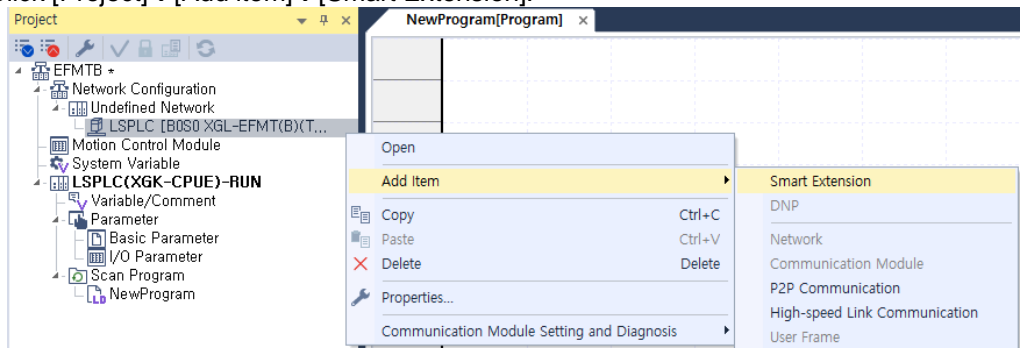
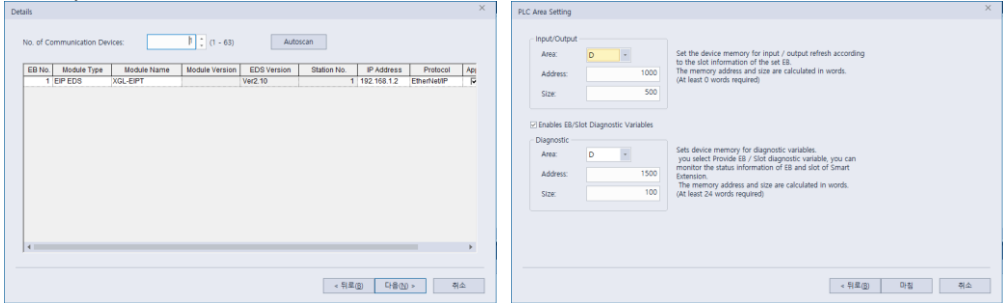
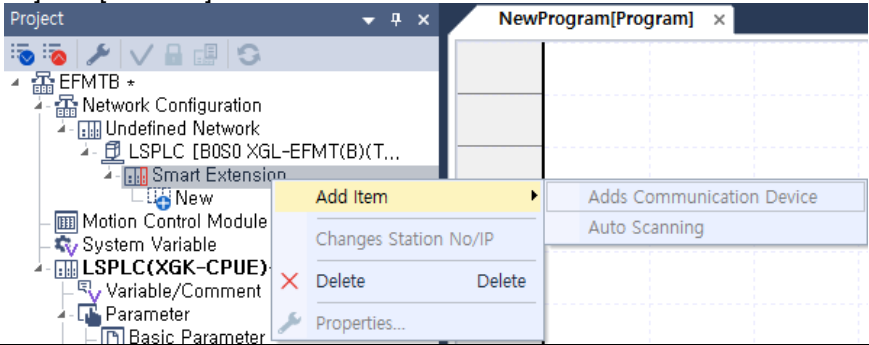
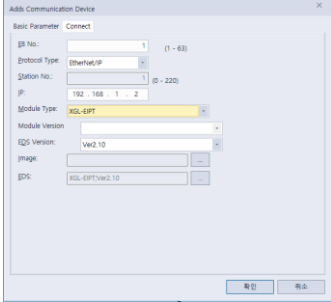
Sequence	Setting process	Setting method
6	Smart expansion/communication device registration (auto scan)	<p>Click [Project]→[Add item]→[Smart Extension].</p>  <p>1) Select “Autoscan” on the [Overview]→[Details] window to automatically register the connected network. (PLC system should be connected in [Online]→[Connect] before Autoscan.)</p> <p>2) Set input / output variables and diagnostic variables as initial values in the [PLC Area Setting] window. Then proceed to Section 8.</p> 
7	communication device registration (manual)	<p>1) Click [Smart Extension]→[Add Item]→ [Add Communication Device].</p> <p>2) In the [Adds Communication Device] window, enter the contents of the [Basic Parameter] and [Connect] tab.</p>  <p>1) Click [Sets EIP Details] under XGL-EIPT of Smart Extension to register the pre-registered Tag1 as the local tag and the Tag3 as the remote tag.</p> 

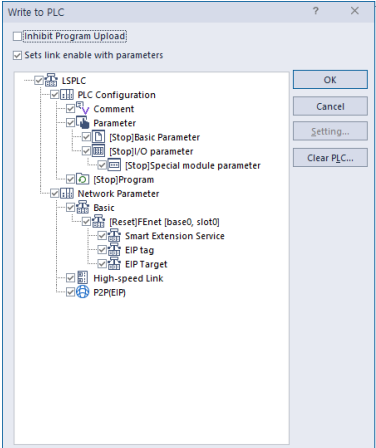
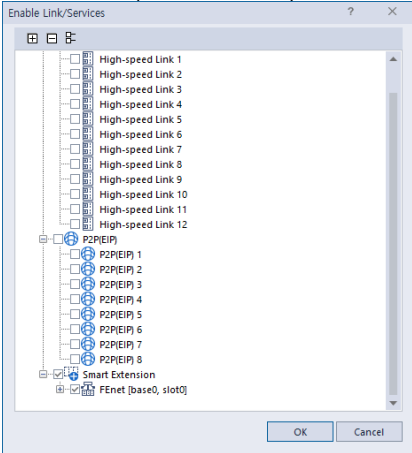
Sequence	Setting process	Setting method																												
8	Sets EIP Detail	<p>1) Double-click the registered EB to open a window and select [Sets EIP Details].</p> <p>2) Set the operation mode, I/O type, connection type, parameters, transmission cycle, timeout, local tag, and remote tag.</p> <table border="1" data-bbox="475 506 1496 599"> <thead> <tr> <th>Index</th> <th>Operation Mode</th> <th>I/O type</th> <th>Connection type</th> <th>Function</th> <th>Parameter</th> <th>Parameter contents</th> <th>Conditional flag</th> <th>Transmission period(ms)</th> <th>Timeout</th> <th>Data Type</th> <th>Local tag</th> <th>Remote tag</th> <th>Data count</th> </tr> </thead> <tbody> <tr> <td>0</td> <td>Implicit Connection</td> <td>2.Read Only(TAG)</td> <td>Point to Point</td> <td></td> <td>Parameter</td> <td>T20 Tag Size:1 Q21 Tag Size:0</td> <td></td> <td>200</td> <td>0.RPI x4</td> <td>WORD</td> <td>###/D00010</td> <td>###</td> <td>1</td> </tr> </tbody> </table>	Index	Operation Mode	I/O type	Connection type	Function	Parameter	Parameter contents	Conditional flag	Transmission period(ms)	Timeout	Data Type	Local tag	Remote tag	Data count	0	Implicit Connection	2.Read Only(TAG)	Point to Point		Parameter	T20 Tag Size:1 Q21 Tag Size:0		200	0.RPI x4	WORD	###/D00010	###	1
Index	Operation Mode	I/O type	Connection type	Function	Parameter	Parameter contents	Conditional flag	Transmission period(ms)	Timeout	Data Type	Local tag	Remote tag	Data count																	
0	Implicit Connection	2.Read Only(TAG)	Point to Point		Parameter	T20 Tag Size:1 Q21 Tag Size:0		200	0.RPI x4	WORD	###/D00010	###	1																	
9	Program download	<p>1) In [Online]→[Write] window ,Click ok.</p> <p>2) Check Smart extension, check FNet basic settings, smart extension service, EIP tag, and EIP target, and then click OK.</p> 																												
10	Enable Services	<p>In the [Online] → [Communication module setting and diagnosis] → [Enable Link/Service] window, check smart extension FNet (base0, slot 0) and click OK.</p> 																												

2) Adapter setting(XGL-EIPT)

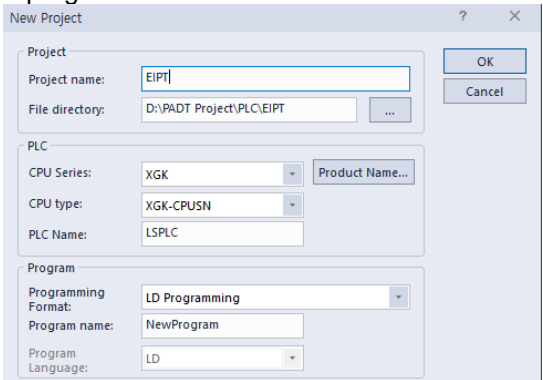
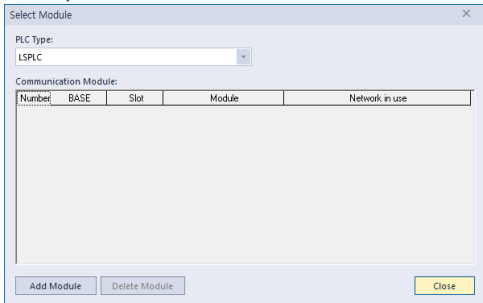
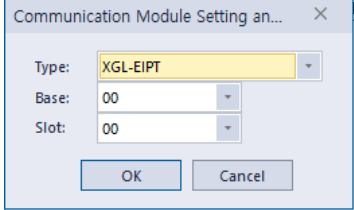
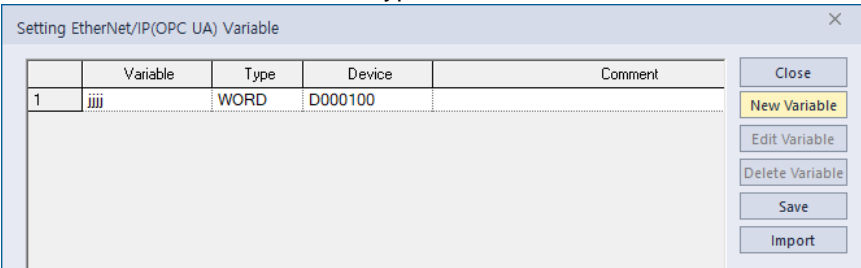
Sequence	Setting process	Setting method																						
1	Create new project	<p>1) [Project]→Open [New Project] and enter the project name, CPU series, CPU type, programming format, and program name.</p> 																						
2	Add Undefined network	<p>1) Select [Undefined Network]→[Add item]→ [Communication module]. 2) In the [Select Module] window, click “Add module”.</p>  <p>1) Set Type, Base and Slot in Communication module settings. After that, select ok button in [Communication module setting and Diagnosis] and module setting is completed.</p> 																						
3	Tag registration	<p>1) XGI CPU - Click [Project]→[EtherNet / IP (OPC UA) Tag Settings]. - Select "New Variable" to add variables, Type, and device.</p>  <p>2) XGI/R CPU - Add variables in the [Global / Direct Variables] or [Local Variables] window of the project tree. - Check the EIP / OPC UA item.</p> <table border="1" data-bbox="431 1966 1516 2031"> <thead> <tr> <th></th> <th>Variable Kind</th> <th>Variable</th> <th>Type</th> <th>Address</th> <th>Initial Value</th> <th>Retain</th> <th>Used</th> <th>EIP/OPC UA</th> <th>HMI</th> <th>Comment</th> </tr> </thead> <tbody> <tr> <td>1</td> <td>VAR_GLOBAL</td> <td>iiii</td> <td>WORD</td> <td>%MW100</td> <td></td> <td><input type="checkbox"/></td> <td><input type="checkbox"/></td> <td><input checked="" type="checkbox"/></td> <td><input type="checkbox"/></td> <td></td> </tr> </tbody> </table> <p>* If you use continuous data, create an Array type variable.</p>		Variable Kind	Variable	Type	Address	Initial Value	Retain	Used	EIP/OPC UA	HMI	Comment	1	VAR_GLOBAL	iiii	WORD	%MW100		<input type="checkbox"/>	<input type="checkbox"/>	<input checked="" type="checkbox"/>	<input type="checkbox"/>	
	Variable Kind	Variable	Type	Address	Initial Value	Retain	Used	EIP/OPC UA	HMI	Comment														
1	VAR_GLOBAL	iiii	WORD	%MW100		<input type="checkbox"/>	<input type="checkbox"/>	<input checked="" type="checkbox"/>	<input type="checkbox"/>															

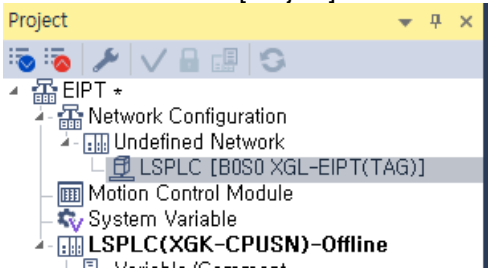
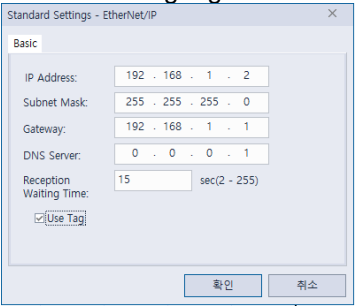
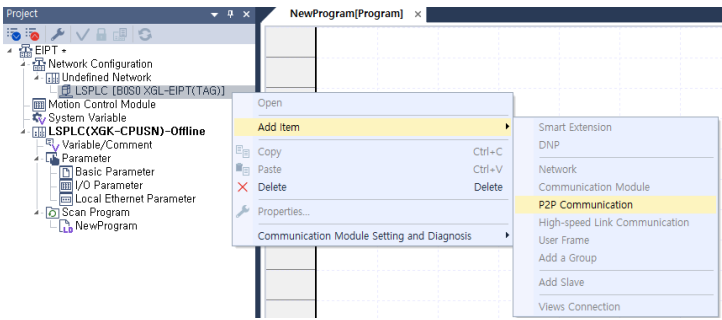
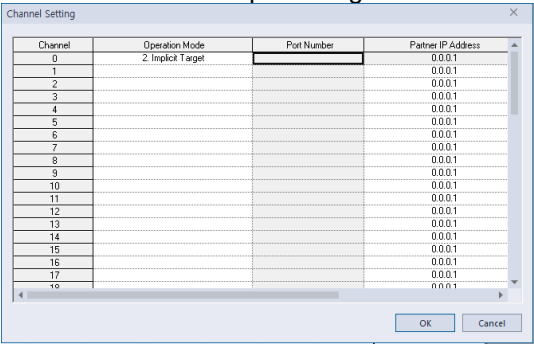
Sequence	Setting process	Setting method																																	
4	Standard settings	<p>Double-click the communication module in the [Project] window.</p>  <p>In the [Standard settings] window, set the IP address, subnet mask, gateway, DNS server, waiting time, and tag usage. Check when using tag information in EIP module.</p> 																																	
5	Service settings	<p>Click [Project]→[Add item]→[P2P Communication]. Select among P2P parameter window No. 1 ~ 8</p>  <p>1) Double-click the EIP channel to set the channel. 2) Set the operation mode of channel 0 to Implicit Target.</p>  <p>1) Double-click the EIP block to set the block. 2) Register a local tag in channel 0.</p> <table border="1" data-bbox="436 1954 1504 2033"> <thead> <tr> <th rowspan="2">Index</th> <th rowspan="2">Channel</th> <th rowspan="2">Operation Mode</th> <th rowspan="2">I/O type</th> <th rowspan="2">Connection type</th> <th rowspan="2">Function</th> <th rowspan="2">Parameter</th> <th rowspan="2">Parameter contents</th> <th rowspan="2">Conditional flag</th> <th rowspan="2">Transmission period(ms)</th> <th rowspan="2">Timeout</th> <th rowspan="2">Data Type</th> <th colspan="3">tag settings</th> </tr> <tr> <th>Local tag</th> <th>Remote tag</th> <th>Data count</th> </tr> </thead> <tbody> <tr> <td>0</td> <td>0</td> <td>Implicit Target</td> <td></td> <td></td> <td></td> <td></td> <td></td> <td></td> <td></td> <td></td> <td>WORD</td> <td>#D000100</td> <td></td> <td>1</td> </tr> </tbody> </table>	Index	Channel	Operation Mode	I/O type	Connection type	Function	Parameter	Parameter contents	Conditional flag	Transmission period(ms)	Timeout	Data Type	tag settings			Local tag	Remote tag	Data count	0	0	Implicit Target									WORD	#D000100		1
Index	Channel	Operation Mode													I/O type	Connection type	Function	Parameter	Parameter contents	Conditional flag	Transmission period(ms)	Timeout	Data Type	tag settings											
			Local tag	Remote tag	Data count																														
0	0	Implicit Target									WORD	#D000100		1																					

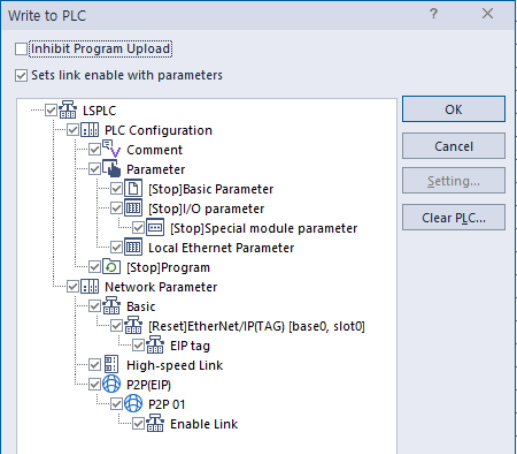
Sequence	Setting process	Setting method
6	Program download/ Set link enable	<p>On [Online]→[Write] window, check Basic settings, EIP tag, P2P and Enable link and click OK.</p>  <p>Link enable settings can also be set in [Online]→[Communication module setting and diagnosis]→[Enable Services].</p>

7.3.9 Diagnosis

Ethernet module (FEnet) does not provide diagnostic function for EIP target/server (Periodic/Non-periodic) among EtherNet / IP services, but only diagnostic function for EIP connection (Period/Non-period).

The EIP connection service is integrated into the Smart Extension Service and also includes diagnostics.

For the diagnosis function of smart extension service, refer to '4.4 Smart extension diagnosis function'.

The screenshot shows a software window titled "Status by service" with a close button (X) in the top right corner. It features several tabs: "Dedicated Service", "P2P Service", "HS Link Service", and "Smart Extension". The "Smart Extension" tab is active.

Under "Standard Information", there are input fields for "Base No.:" (value: 0) and "Slot No.:" (value: 9). Under "Service information", there is a "Service Status" dropdown set to "Enable", and three scan time fields: "SCAN MAX:" (0.0 ms), "SCAN MIN:" (6553.5 ms), and "SCAN CURR:" (0.0 ms).

A table displays service details:

EB No.	Protocol	Station No./IP	Service	EB Status	Service Count	EB Detach Count
11	EIP	192.168.1.11	Event service		30708944	0
12	EIP	192.168.1.12	Event service		31261495	0

Below this table, a detailed view for Slot 0 is shown, highlighted with a red border:

Slots	Types	Status	Error Code	Service Count	Error Count	Slot Flag
0	Period service	CONNECT	READY	0x0	31261495	0

At the bottom of the window, there are buttons for "Save the file", "Clear Scan", "Clear Flag", "Read", and "Refresh". A "Close" button is located in the bottom right corner.

### 7.3.10 System configuration

The Ethernet module provides both EtherNet / IP scanner/adaptor functions.

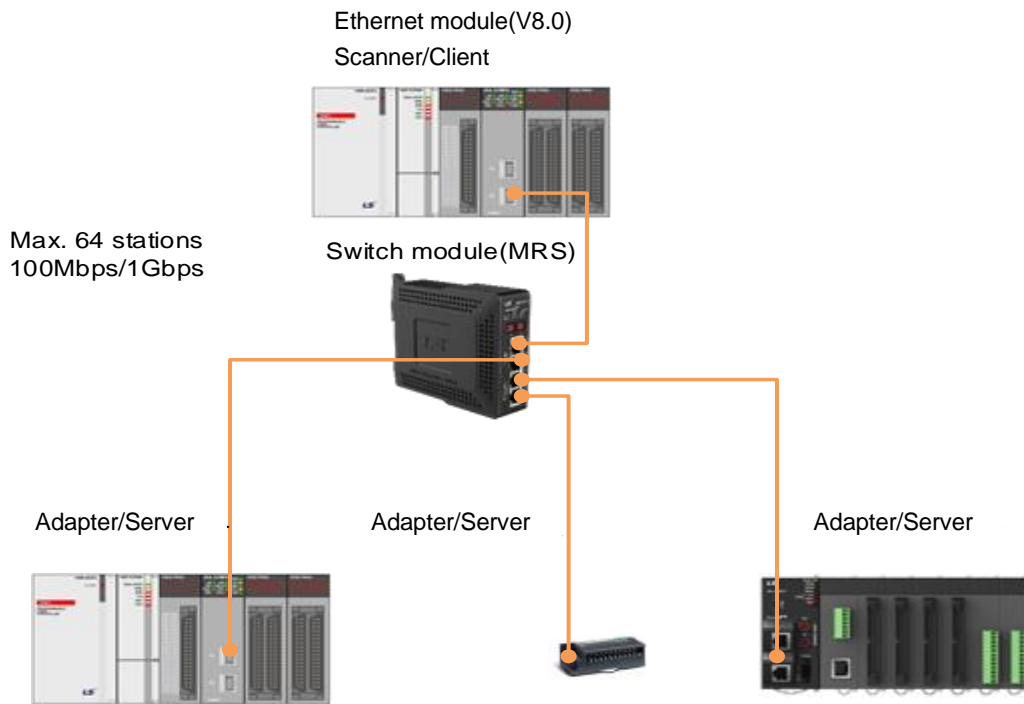

## 7.4 OPC UA function

OPC Unified Architecture (IEC 62541) is an interoperability standard for secure and reliable information exchange, making it suitable for industrial applications. Based on client-server model, it is a communication protocol applicable from sensor level to cloud and has the following features.

(1) Multi / cross platform support

Unlike OPC Classic, which was dependent on the Windows operating system, it is not limited to one operating system or programming language, coordinate in it can be operated on various devices (Embedded Device).

(2) Strong security

It supports authentication and authorization through signing, encryption, and data integrity (consistency, accuracy, and validity). Authentication uses X.509 certificates.

(3) Support a Service Oriented Architecture

XGT OPC UA server module can access flags, local and global variables set in PLC from OPC UA client. Based on OPC UA Specification V1.03, binary protocol (UA Binary) is used, and binary can be downloaded from module of Ethernet module V6.0 or higher and can be used with XGK, XGI, and XGR CPU.

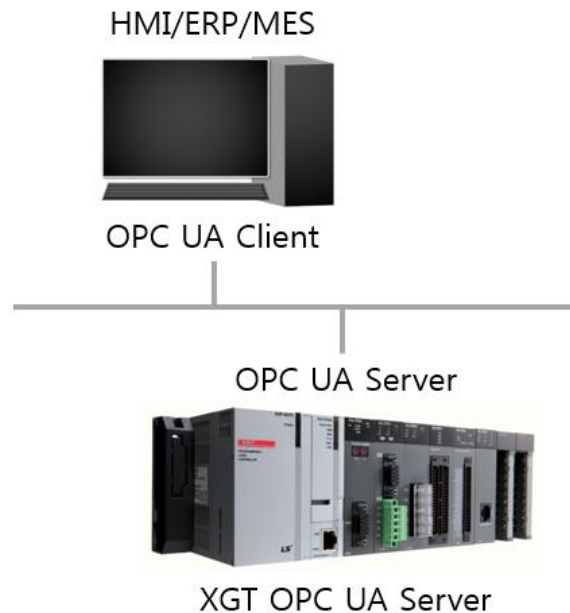

### 7.4.1 Overview

XGT OPC UA module has the following features

- Message encryption feature
- Authentication via Certificate
- User security functions
- Variable read / write function
- Variable Monitoring (MonitoredItem) Function through Subscription
- Alarm / Event function for variables
- History function for variables

The maximum performance specification of XGT OPC UA module is as follows.

- Connect with up to 10 OPC UA clients (Connect 10 Sessions with OPC UA Client).
- Up to 7000 variables can be set for OPC UA.
- Have up to 50 subscription channels, 10 per session.
- Register 1000 and up to 5000 variables (MonitoredItem) per subscription channel.
- Security Profiles support No Security, 128Rsa15 Sign, 128Rsa15 Sign & Encrypt, 256 Sign, 256 Sign & Encrypt, 256Sha256 Sign, 256Sha256 Sign & Encrypt.
- Alarm / Event can register up to 100 LimitLevel and OffNormal.
- History function can save up to 3,000 history of maximum 64 for variables.

### (1) OPC UA server available version

To use the OPC UA server, you must use the version below.

- XG5000: V4.25 or higher
- XGK CPU OS: V4.57 or higher
- XGK CPU(N) OS: V1.21 or higher
- XGI CPU OS: V4.08 or higher
- XGI CPU(N) OS: V1.31 or higher
- XGR CPU O/S: V2.73 or higher
- FEnet module H/W version: V2.0 only

### (2) Ethernet module OS upgrade to use OPC UA server

To use the OPC UA server, you need to upgrade the OS of the Ethernet module. (Only V7.x version is supported)

- 1) Download OPC UA server OS from LS ELECTRIC website (<http://www.ls-electric.com/>).
- 2) After installing the Ethernet module on the system, supply power to the PLC
- 3) Connect to PLC with XG5000 and change the operation mode to STOP.
- 4) Select on [Online]-[Communication module setting and Diagnosis]-[OS Upload / Download].

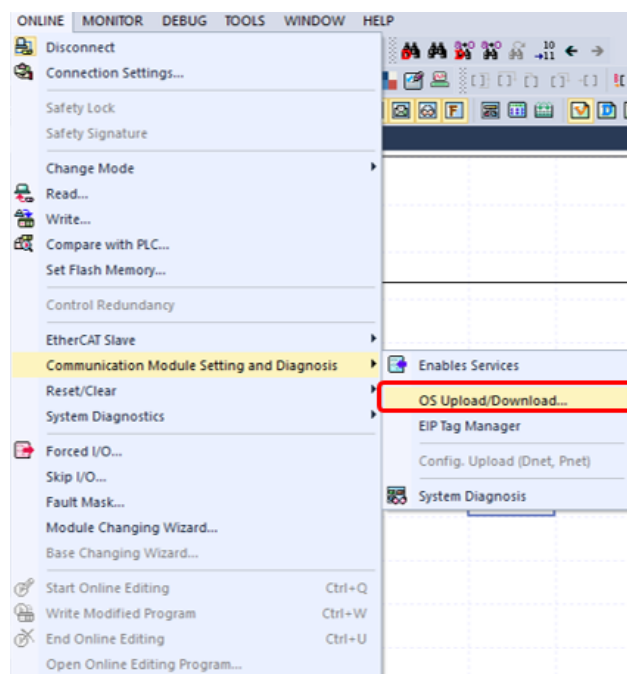

- 5) Check the base / slot number where the Ethernet module is installed, select the module and click the [BBMBoot] button. The PLC will reset to operate in BBMBoot mode.

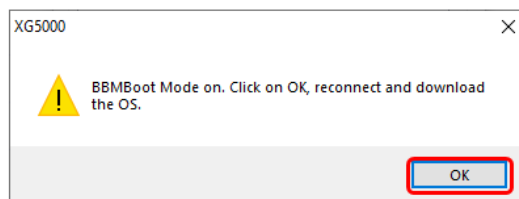
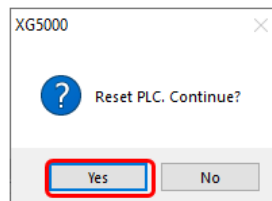
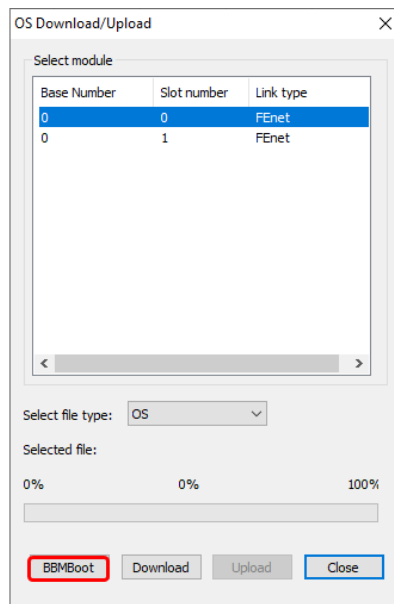

6) Select on [Online]→[Communication module setting and Diagnosis]→[OS Upload / Download].

7) After selecting Ethernet module, select “OS” in file type selection and click [download] button. When the file search window appears, select the OS file downloaded from the homepage.

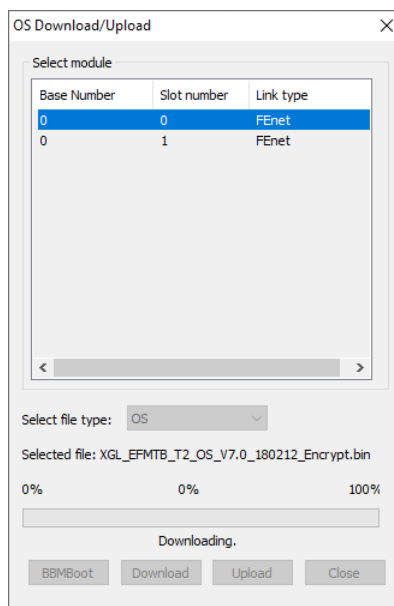

8) Wait for the progress bar to reach 100% and click the [OK] button.

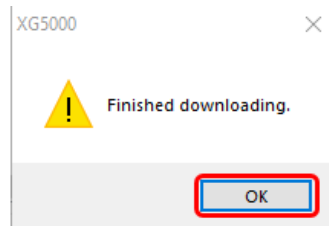

**Notes**

(1) Only Ethernet modules (V6.0 or higher) manufactured after January '18 can be upgraded to OS that supports OPC UA server. If you change to the firmware version V7.x version, OPC UA is supported and other V6.x or V8.x version does not support OPC UA function.

(2) If the H/W version is V3.0 or higher, firmware change to the OS for OPC UA is not supported. Please purchase and use the OPC UA dedicated module (XGL-EOPCT).

※ How to check the H/W version: Connect to the PLC, select the [Online] - [System Diagnostics] - [I/O Information] menu, and then double-click the FENet module in the "I/O Information" window or select the module and click the [Details] button to check.

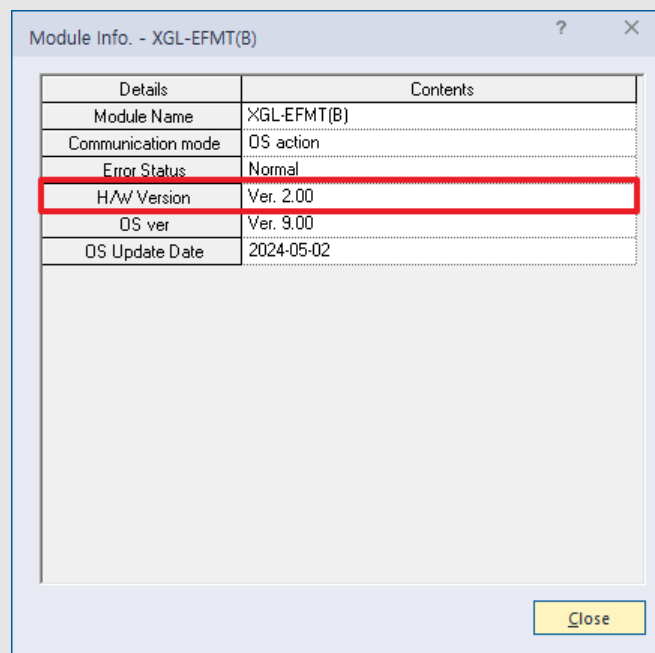

## 7.4.2 Parameter setting

OPC UA server parameter is divided into basic setting, secure channel setting, user authentication setting parameter, and selecting variable to use in OPC UA. It is downloaded through XG5000.

### (1) Standard settings

To set up OPC UA server, you have to select “OPC UA” option in standard settings of Ethernet communication module.

Standard Settings - FEnet

Basic Settings Host Table Settings Sets EIP Server

TCP/IP Settings

Station No.: 0

Media: Port1: AUTO Port2: AUTO

IP address: 192 . 168 . 1 . 2

Subnet Mask: 255 . 255 . 255 . 0

Gateway: 192 . 168 . 1 . 1

DNS Server: 0 . 0 . 0 . 1

DHCP  Relay  OPC UA

No. of Dedicated Connections: 3 (1 - 16)

Receive Time Out Settings

Client: 60 sec(2 - 255)

Server: 15 sec(2 - 255)

Driver Setting

Server Mode: XGT server

Modbus Settings

RAPIEnet Settings: Disable

OK Cancel

7.4.3 OPC UA settings

(1) Select on [Communication module setting and Diagnosis] → [OPC UA setting] menu to move to setting screen.

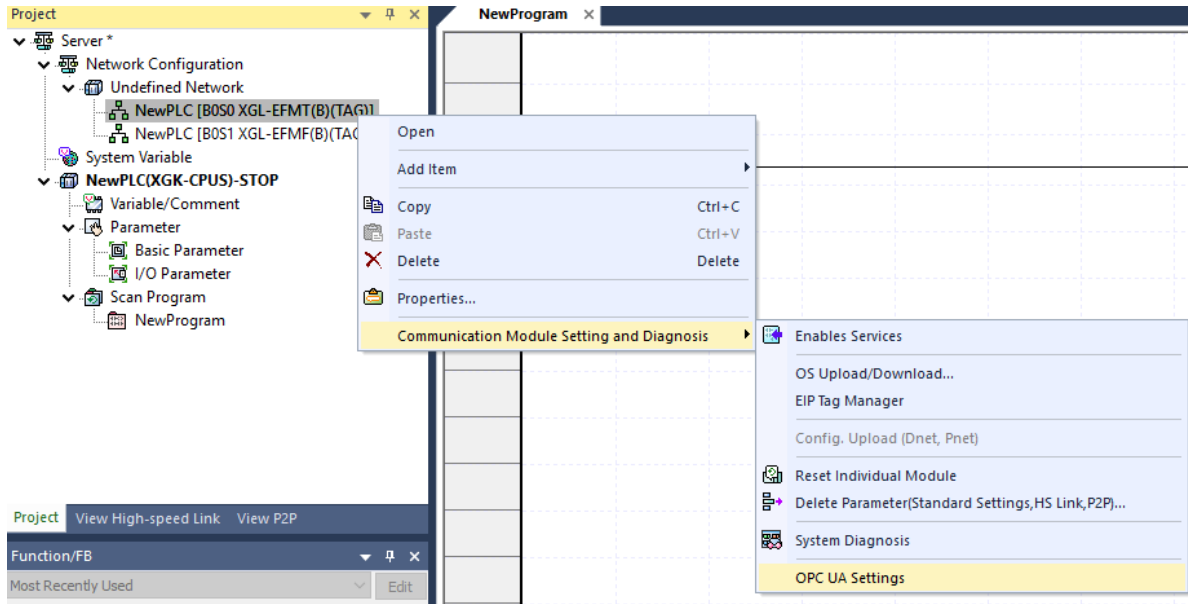

(2) Basic settings

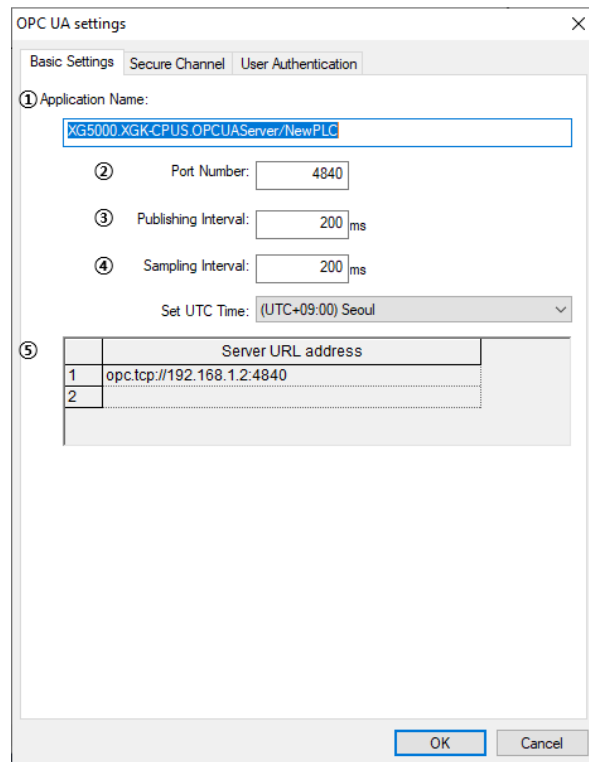

- 1) Application name: The name of the OPC UA server displayed when the OPC UA client connects to the server's URL. "it is set by default as 'XG5000 Set PLC Type.OPCUAServer / Set PLC Name'" and you can change it.
- 2) Port number: Enter the number to be used as the OPC UA server port. The default value is set to 4840, which is the OPC UA server port default. It can be changed by the user except for port numbers (502, 2002, 2004, 2005, 2007, 2008, etc.) already defined among the decimal numbers from 1 to 65535.

- 3) Publishing Interval: set the minimum frequency that the OPC UA server can send to OPC UA clients. The default value is 200ms and can be changed by the user from 20ms to 1000ms.
- 4) Interval Set the sampling cycle between PLC CPU and OPC UA server communication module for the variable registered as MonitoredItem. The default value is 200ms and can be changed by the user from 20ms to 1000ms. However, the sampling cycle is affected by the scan time of the PLC CPU.
- 5) Server URL address: This is the address used by the OPC UA client to enter the OPC UA server address. "It is displayed as 'opc.tcp:// communication module's IP address: OPC UA port number" and the user cannot directly modify it. The IP address of the communication module and the port number of OPC UA can be changed at the same time.

(3) Secure Channel

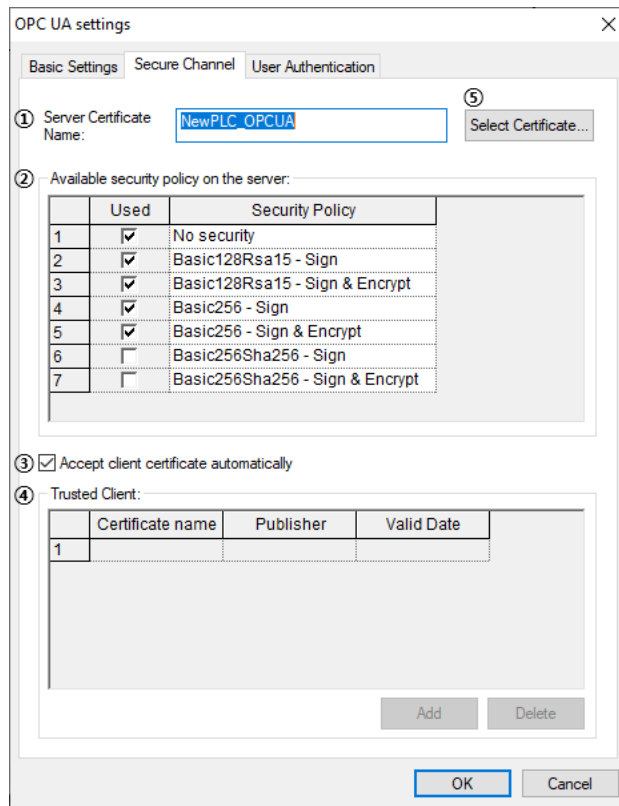

- 1) Server certificate name: displays part of the file name of the certificate to use as the server certificate.
- 2) Available security policies on the server: Displays the policies available for encryption with the XGT OPC UA server module. When connecting to an OPC UA server from an OPC UA client, you can select one of the selected security policies to connect.
- 3) Accept client certificate automatically: select this when you do not have a certificate for the client you want to connect to or when you want to automatically authenticate all clients.

4) Trusted client: register a certificate for trusted clients connecting to the OPC UA server. Unchecked the “Automatically accept all client certificates” check box in 3) to enter the file.

5) Select Certificate: Enroll by issuing your own certificate or selecting a certificate stored on your PC.

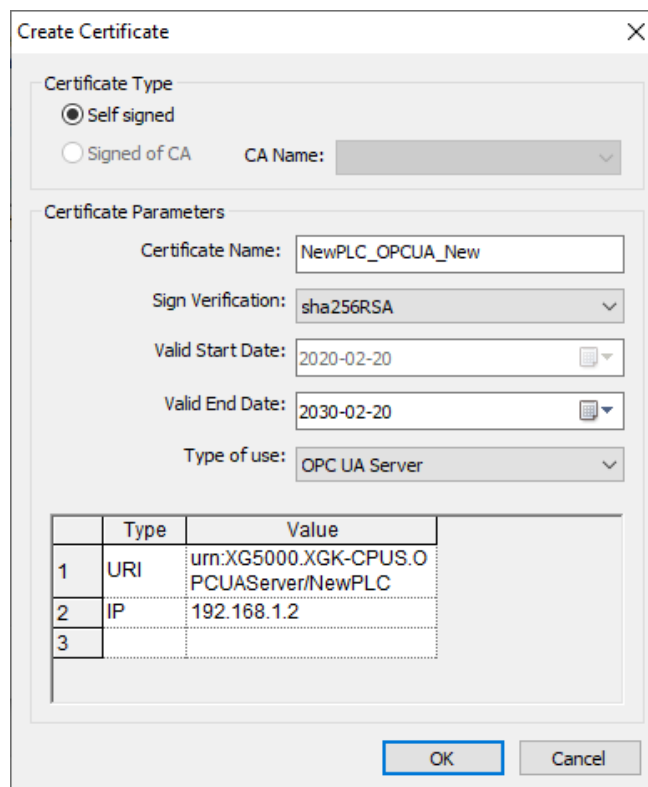
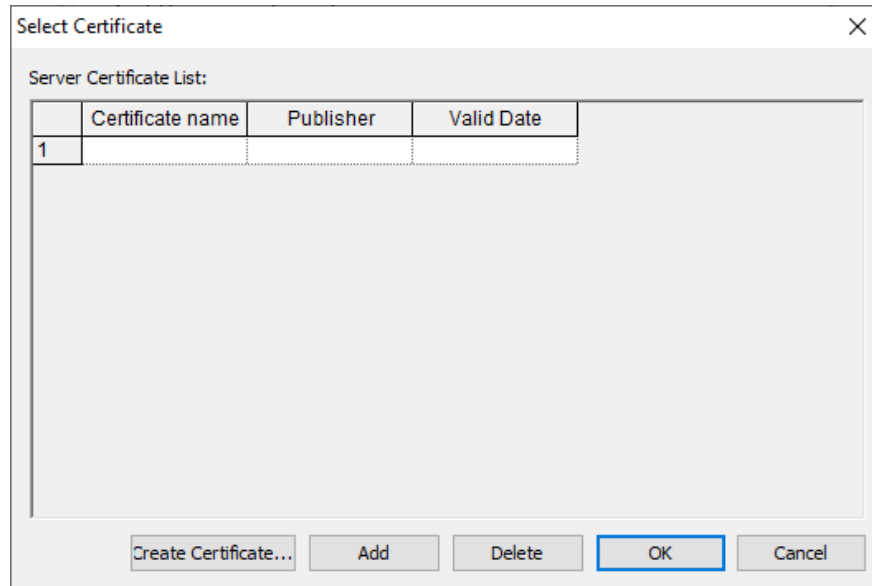

## (4) User Authentication

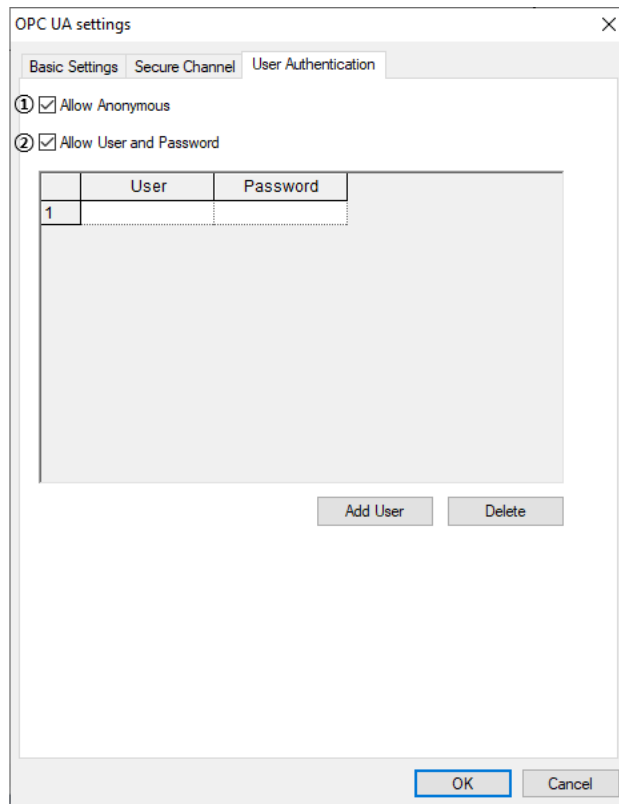

1) Allow anonymous access: When connecting without specifying a user ID and password, this function accepts the client's connection for the request.

2) Allow User and Password access: Check the user ID and password to determine if the client is connected.

## 7.4.4 Variable registration

The OPC UA server registers and uses server variables for use by OPC UA clients.

## (1) XGK CPU

Add OPC UA server variables on [Project]-[Setting EtherNet / IP (OPC UA) Variable] menu.

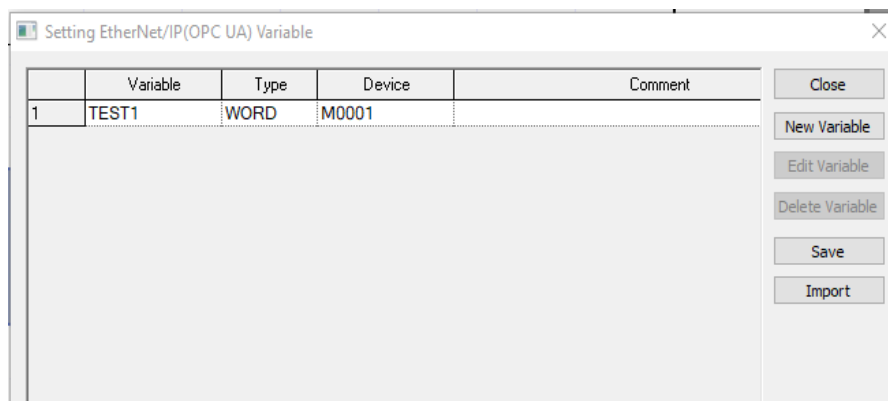

(2) XGI/R CPU

Add OPC UA server variables by selecting “EIP / OPC UA” check box in Global / Direct Variable window or Local Variable window.

Global Variable   Direct Variable Comment   Flag										
	Variable Kind	Variable	Type	Address	Initial Value	Retain	Used	EIP/OPC UA	HMI	Comment
1	VAR_GLOBAL	TEST	WORD	%MW100		<input type="checkbox"/>	<input type="checkbox"/>	<input checked="" type="checkbox"/>	<input type="checkbox"/>	

7.4.5 Setting Download

After setting up OPC UA server and selecting parameters, use [Online] → [Write] menu to download OPC UA server parameters.

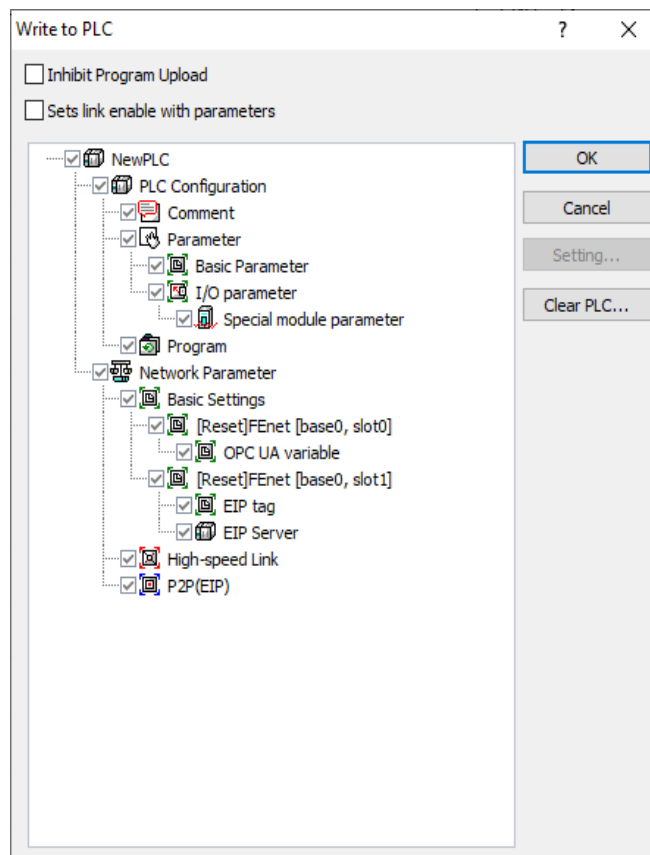

## 7.5 Server service user setting function

### 7.5.1 Overview

You can add each pre-defined server port number and consecutive number of ports.

### 7.5.2 Setting Method

If you enable “user defined port” in “Standard settings” – “Security Settings”, you can change the settings for the servers below.

- (1) XG5000 Port (TCP): Port number changeable (Default: TCP No. 2002)
- (2) XGT Server Port (TCP): Port number and additional port can be set (Default: TCP No. 2004)
- (3) XGT Server Port (UDP): Port number and additional port can be set (Default: UDP No. 2005)
- (4) Expansion Server1 Port (TCP): Port number and additional port of expansion server 1 can be set (Default: TCP No. 5002)
- (5) Expansion Server2 Port (TCP): Port number and additional 2 port can be set (Default: TCP No. 9600)

User custom port

Continuous Setting

	Port Number	Additional Port
XG5000 Port(TCP)		
XGT Server Port(TCP)		
XGT Server Port(UDP)		
Extend Server1 Port(TCP)		
Extend Server2 Port(TCP)		

#### Notes

- (1) When changing the port number for server functions except for the XG5000 connection port, communication with the existing port number is also possible.
- (2) The number of additional ports increases the port number by the number from the port number set by the user and waits for a client connection. (Up to 15 can be possible)
- (3) If continuous setting is selected, the port numbers set by the user are arranged sequentially from the XG5000 port to the extension server 2 port number with the offset set by the user.

## 7.6 DNP3 Server

### 7.6.1 Overview

(1) Protocol overview

DNP3 (distribute Network Protocol 3) is a protocol standard that defines communication rules between computers and is used to collect various types of data and control devices.

(2) DNP3 basic specifications

- DNP3-L3+ Support
- DNP3 Server: Max 1ch.
- Data Point: Max 5,000ea
- Event Data Buffer: Max 100,000ea
- Event data Retention Enable (Only with XGI-CPUZ3/5/7 CPU)

(3) DNP3 support version information

- Communication module: XGL-EFMxB V8.80 or higher
- CPU: XGI-CPUx V4.30 or higher, XGI-CPUUN V2.00 or higher, XGI-CPUZx V1.50 or higher
- PADT: XG5000 V4.76 or higher

### 7.6.2 Server operation

(1) Program sequence

Connect to the PLC and set in the order below.

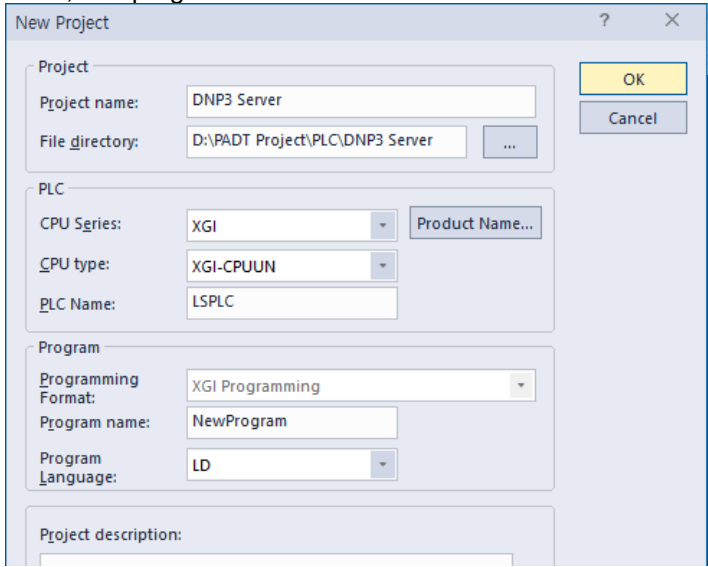
sequence	Setup process	How to set up
1	Create a new project	<p>1) Open [Project] → [New Project] and enter the project name, CPU series, CPU type, programming format, and program name.</p> 

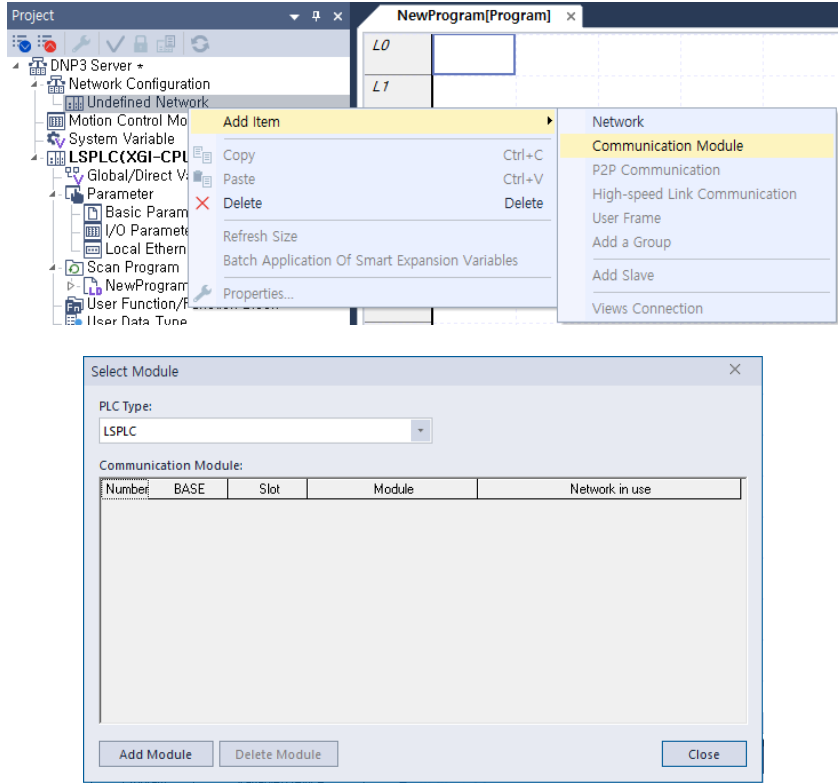
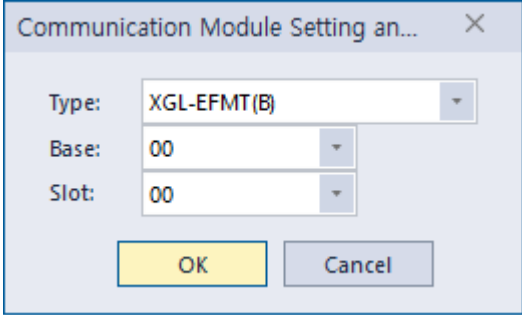
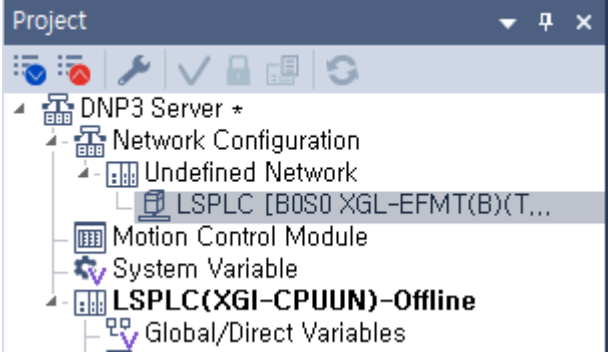
sequence	Setup process	How to set up
2	Add communication module	<p>1) Right-click [Undefined Network] and select [Add Item] → [Communication Module].                      2) In the [Select Module] window, click “Add Module”.</p>  <p>3) Set the type, base, and slot in [Communication Module Setting] and click the OK button.</p> 
3	Network standard settings	<p>1) Double-click the communication module in the [Project] window.</p> 

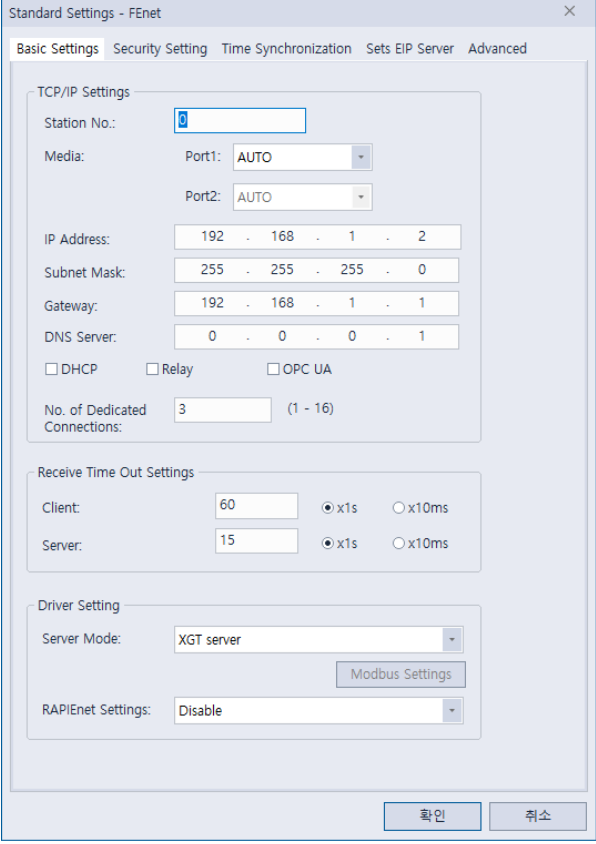
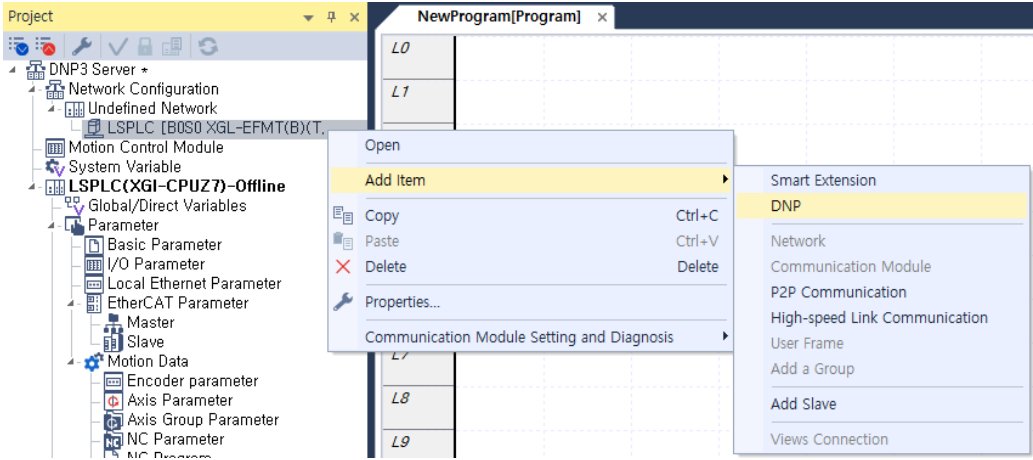
sequence	Setup process	How to set up
		<p>2) In the [Basic Settings] window, set [TCP/IP settings], [Receive Timeout settings], and [Driver settings].</p> 
4	Add service DNP3	<p>1) Right-click the communication module and select [Add Item] → [DNP].</p> 

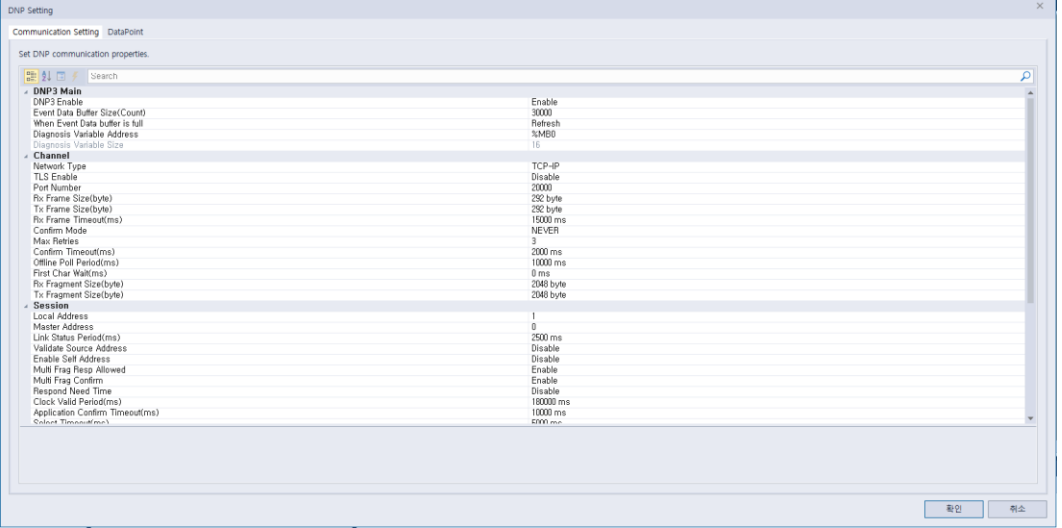
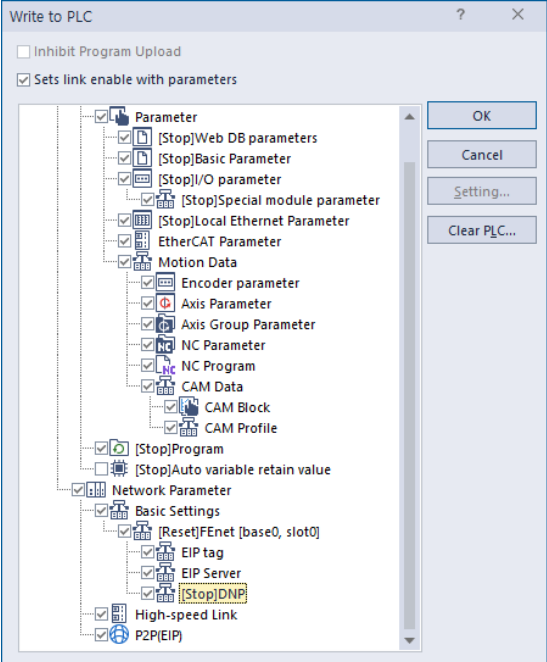
sequence	Setup process	How to set up
5	DNP3 parameter settings	<p>1) Double-click DNP. 2) Set [Communication Setting] and [DataPoints] of DNP3.</p> 
6	Program download	<p>In the [Online] → [Write] window, Click OK. When downloading the project, select the DNP checkbox.</p> 

7.6.3 DNP3 Parameter Setting

(1) DNP3 communication setting details

Parameter	Value Scope	Default Value	Description
DNP3 Enable	Enable/Disable	Enable	Define DNP3 Service Enable/Disable
Event Data Buffer Size(Count)	100..100000	30000	Max count of event data can be stored
When Event Data buffer is full	Refresh/Stop	Refresh	What to do when the number of event data stored is exceeded Refresh: Delete the oldest data and save new event data Stop: Ignore new data
Diagnosis Variable Address	M Area Only	%MB0	Memory address where diagnostic variables will be stored
Diagnosis Variable Size	16	16	
Network Type	TCP-IP UDP-IP TCP-UDP	TCP-IP	DNP3 communication method TCP-IP: Provides DNP3 service through TCP/IP protocol. UDP-IP: Provides DNP3 service through UDP/IP protocol TCP-UDP: DNP3 service operates through TCP/IP protocol while simultaneously receiving and processing UDP/IP broadcasting messages.
TLS Enable	Enable/Disable	Disable	
Port Number	0..65535	20000	Port Num. for DNP3 Server
Rx Frame Size(byte)	24..292	292	Maximum received message frame size in the data link layer
Tx Frame Size(Byte)	24..292	292	Maximum transmit message frame size in the data link layer
Rx Frame Timeout(ms)	0..4294967295	15000	Waiting time until frame reception is completed after frame synchronization
Confirm mode	Never Sometimes Always	Never	Specifies when a link layer confirmation can be requested
Max Retries	0..255	3	Indicates the retry count of link layer confirmation time-outs
Confirm Timeout(ms)	0..4294967295	2000	Waiting time when requesting Confirm from link layer
Offline Poll Period(ms)	0..4294967295	10000	Specifies the duration to re-establish communication for an offline session
First Char wait	0..65535	0	Indicates the minimum time between reception and transmission
Rx Fragment size	24..2048	2048	Indicates the maximum message frame length in the data link layer
Tx Fragment size	24..2048	2048	Indicates the maximum message frame length in the data link layer

Parameter	Value Scope	Default Value	Description
Local Address	1..65520	1	Indicates the source address for this session
Master Address	1..65520	0	Indicates the destination address for this session
Link Status Period(ms)	0..4294967295	2500	Indicates the period to send link status requests if no DNP3 frames are received on this session
Validate Source address	Enable Disable	Disable	Specifies if the source address is validated in received frames
Enable Self Address	Enable Disable	Disable	Responds with its own address so that the master can automatically discover the slave address
Multi Frag Resp Allowed	Enable Disable	Enable	specifies if the application is allowed to send multi-fragment responses
Multi Frag Confirm	Enable Disable	Enable	specifies if the application layer confirmations are requested for no final fragments of a multifragment response
Respond Need Time	Enable Disable	Disable	specifies if this device sets the need time IIN bit in response to this session at startup and after the clock valid period has elapsed
Clock Valid Period(ms)	0..4294967295	1800000	specifies the period for which the clock remains valid after receiving time synchronization
Application Confirm Timeout(ms)	0..4294967295	10000	specifies the period for which the slave DNP3 device waits for the application layer confirmation from the master
Select Timeout(ms)	0..4294967295	5000	specifies the maximum amount of time that a selection remains valid before the corresponding operation is received
Allow Multi CROB Request	Enable Disable	Enable	determines if the objects of the Multiple Control Relay Output block are allowed in a single request
Max Control Request	0..10	10	determines if the maximum number of controls are allowed in a single request
Unsolicited Allowed	Check/Uncheck	Check	determines if the unsolicited responses are allowed
Send Unsolicited When Online	Enable Disable	Disable	determines if the unsolicited null responses are transmitted when the session comes online
Unsolicited Class x Max Events	0..255	5	If unsolicited responses are enabled, UnsolClassXMaxEvents specifies the maximum number of events in the corresponding class to be allowed before an unsolicited response is generated.
Unsolicited Class x Max Delay	0..4294967295	5000	specifies the maximum amount of time after an event in the corresponding class is received before an unsolicited response is generated
Unsolicited Retry Delay	0..4294967295	5000	specifies the time to delay after an unsolicited confirmation time-out before retrying the unsolicited response
Unsolicited Max Retries	0..65535	3	specifies the maximum number of unsolicited retries before changing to the offline retry period
Unsolicited Offline Retry Delay	0..4294967295	30000	specifies the time to delay after an unsolicited time-out before retrying the unsolicited response after UnsolMaxRetries are attempted

(2) DNP3 data point setting details

Data Points can be added, deleted and modified at Datapoint tab.

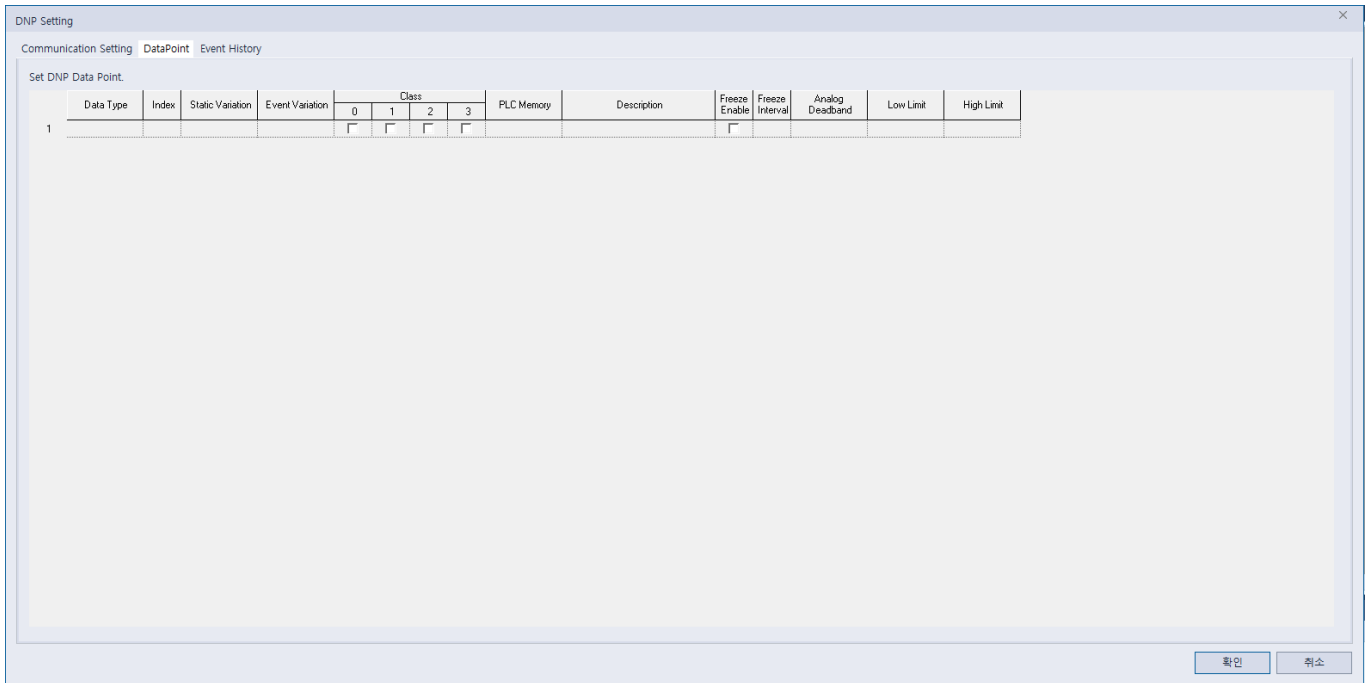

Add Data Point: Double-click an empty space on the data point setup screen and enter the setup data in the pop-up window that is created.

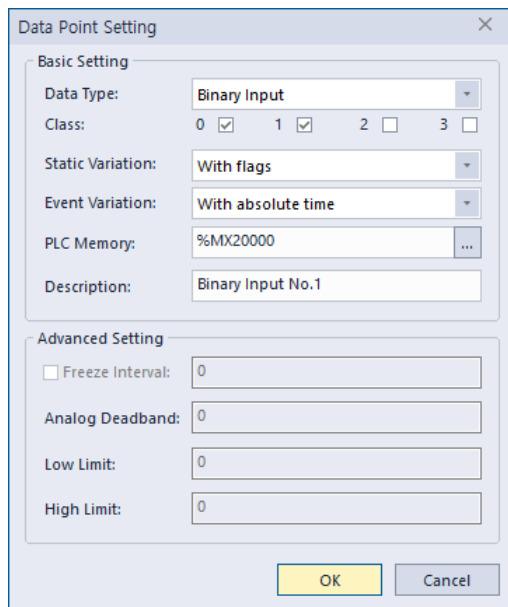

Parameter	Description	Remark
Data Type	Data Type of DataPoint	Binary Input / Binary Output / Counter / Analog Input / Analog Output
Class	Defines the event class of points	Unsolicited is not allowed with class 0 only
Static Variation	Indicates the static variation for data point	See Data Point Variation detailed table
Event Variation	Indicates the event variation for data point	See Data Point Variation detailed table
PLC memory	Indicates address of the register in CPU	
Description	User comment for the data point	
Freeze Enable	Enable Freeze event generation	Binary Counter, Analog Input only
Freeze Interval	Freeze event generation cycle of data points	Binary Counter, Analog Input only
Analog Deadband	Change value of data points that do not generate events based on the last generated event data	Analog Input only
Low Limit	If it is less than the set value, deadband is ignored and an event is generated.	Analog Input only
High Limit	If it is greater than the set value, the deadband is ignored and an event is generated.	Analog Input only

The data types in Static Variation, Event Variation and PLC memory should be match.

Delete Data Point : Select Data Point and press 'DELETE' Key

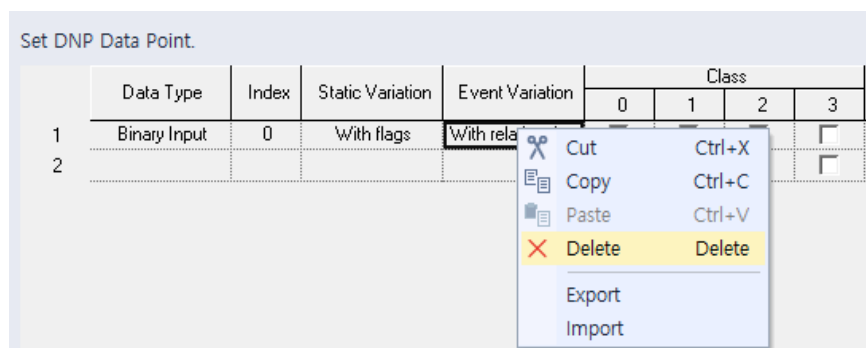

Edit Data Point : Double Click DataPoint which want to edit.

Data Point Variation Detailed Table by Group

Object		Description
Group	Variation	
1	1	Binary Input—Packed format
1	2	Binary Input—With flags
2	1	Binary Input Event—Without time
2	2	Binary Input Event—With absolute time
2	3	Binary Input Event—With relative time
10	1	Binary Output—Packed format
10	2	Binary Output—Output status with flags
11	1	Binary Output Event—Status without time
11	2	Binary Output Event—Status with time
12	1	Binary Command—Control relay output block (CROB)
12	2	Binary Command—Pattern control block (PCB)
12	3	Binary Command—Pattern mask
13	1	Binary Output Command Event—Command status without time
13	2	Binary Output Command Event—Command status with time
20	1	Counter—32-bit with flag
20	2	Counter—16-bit with flag
20	5	Counter—32-bit without flag
20	6	Counter—16-bit without flag
22	1	Counter Event—32-bit with flag
22	2	Counter Event—16-bit with flag
22	5	Counter Event—32-bit with flag and time
22	6	Counter Event—16-bit with flag and time
30	1	Analog Input—32-bit with flag
30	2	Analog Input—16-bit with flag
30	3	Analog Input—32-bit without flag
30	4	Analog Input—16-bit without flag
30	5	Analog Input—Single-prec flt-pt with flag
30	6	Analog Input—Double-prec flt-pt with flag
32	1	Analog Input Event—32-bit without time
32	2	Analog Input Event—16-bit without time
32	3	Analog Input Event—32-bit with time
32	4	Analog Input Event—16-bit with time
32	5	Analog Input Event—Single-prec flt-pt without time
32	6	Analog Input Event—Double-prec flt-pt without time
32	7	Analog Input Event—Single-prec flt-pt with time
32	8	Analog Input Event—Double-prec flt-pt with time

Object		Description
Group	Variation	
40	1	Analog Output Status—32-bit with flag
40	2	Analog Output Status—16-bit with flag
40	3	Analog Output Status—Single-prec flt-pt with flag
40	4	Analog Output Status—Double-prec flt-pt with flag
41	1	Analog Output—32-bit
41	2	Analog Output—16-bit
41	3	Analog Output—Single-prec flt-pt
41	4	Analog Output—Double-prec flt-pt
42	1	Analog Output Event—32-bit without time
42	2	Analog Output Event—16-bit without time
42	3	Analog Output Event—32-bit with time
42	4	Analog Output Event—16-bit with time
42	5	Analog Output Event—Single-prec flt-pt without time
42	6	Analog Output Event—Double-prec flt-pt without time
42	7	Analog Output Event—Single-prec flt-pt with time
42	8	Analog Output Event—Double-prec flt-pt with time
43	1	Analog Output Command Event—32-bit without time
43	2	Analog Output Command Event—16-bit without time
43	3	Analog Output Command Event—32-bit with time
43	4	Analog Output Command Event—16-bit with time
43	5	Analog Output Command Event—Single-prec flt-pt without time
43	6	Analog Output Command Event—Double-prec flt-pt without time
43	7	Analog Output Command Event—Single-prec flt-pt with time
43	8	Analog Output Command Event—Double-prec flt-pt with time

7.6.4 Diagnosis Global Variable

The diagnosis Data is supported as global variables.

(1) DNP3 diagnostic variable area

The DNP3 diagnostic variable area can be set in DNP3 parameters.  
The length is fixed to 16 words.



(2) Registration of diagnostic variables

These variables area can be set in the DNP setting windows and are registered when you close it.

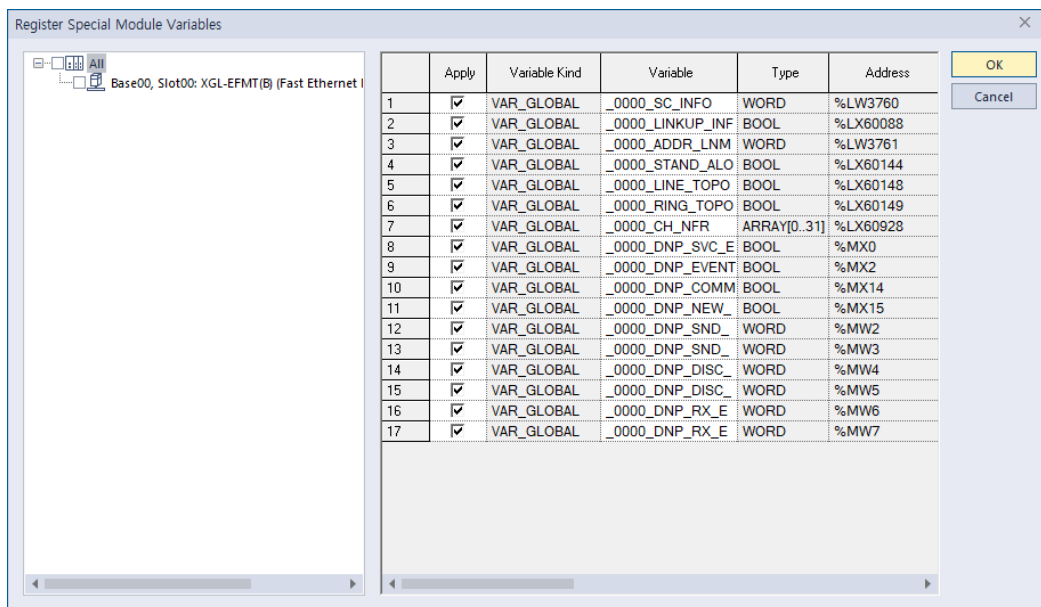
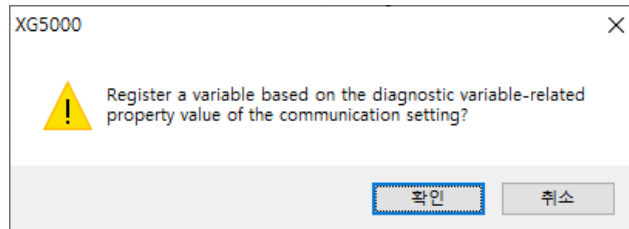

(3) Diagnostic variable list

Variable Name	Type	Description
DNP_SVC_ENABLE	BOOL	DNP: SERVICE ENABLE STATE
DNP_EVENT_BUFFER_STATE	BOOL	DNP: EVENT BUFFER(SEND BUFFER) STATE
DNP_COMM_STATE	BOOL	DNP: CLIENT CONNECTION STATE
DNP_NEW_EVENT_DATA	BOOL	DNP: THERE IS NEW EVENT DATA TO BACKUP
DNP_SND_BUF_CNT_L	WORD	DNP: EVENT DATA BUFFER(SEND BUFFER) COUNT(L)
DNP_SND_BUF_CNT_H	WORD	DNP: EVENT DATA BUFFER(SEND BUFFER) COUNT(H)
DNP_DISC_CNT_L	WORD	DNP: Communication Disconnection Count(L)
DNP_DISC_CNT_H	WORD	DNP: Communication Disconnection Count(H)
DNP_RX_ERR_CNT_L	WORD	DNP: Receive Frame Error Count(L)
DNP_RX_ERR_CNT_H	WORD	DNP: Receive Frame Error Count(H)

7.6.5 DNP3 Event Data log

The Event history can be checked in Event History tab of DNP Setting at the XG5000.

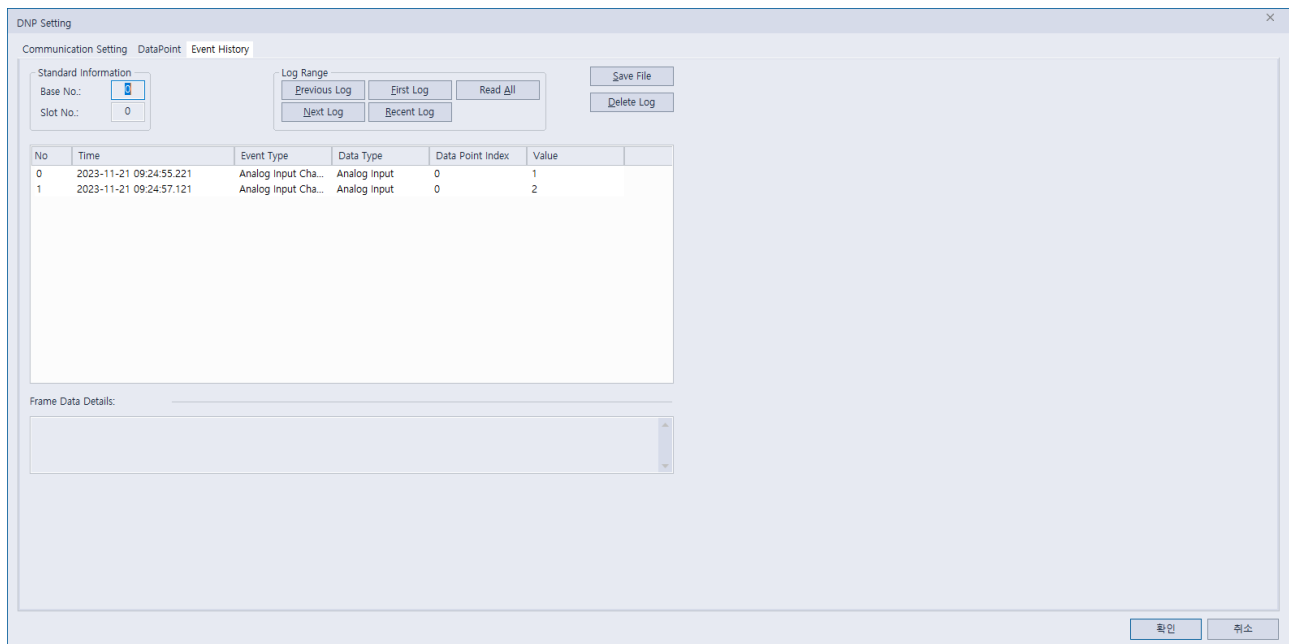

## Chapter 8 Additional functions

### 8.1 Remote communication

This function is XG5000 and remote control function such as program writing, user program download, program debugging and monitor in network system where PLC is connected by Ethernet. Especially, when the devices connected to the network are far apart, it is a convenient function to easily access each device from one place without moving the place. XG5000 remote communication service function can be connected by creating the following logical path.

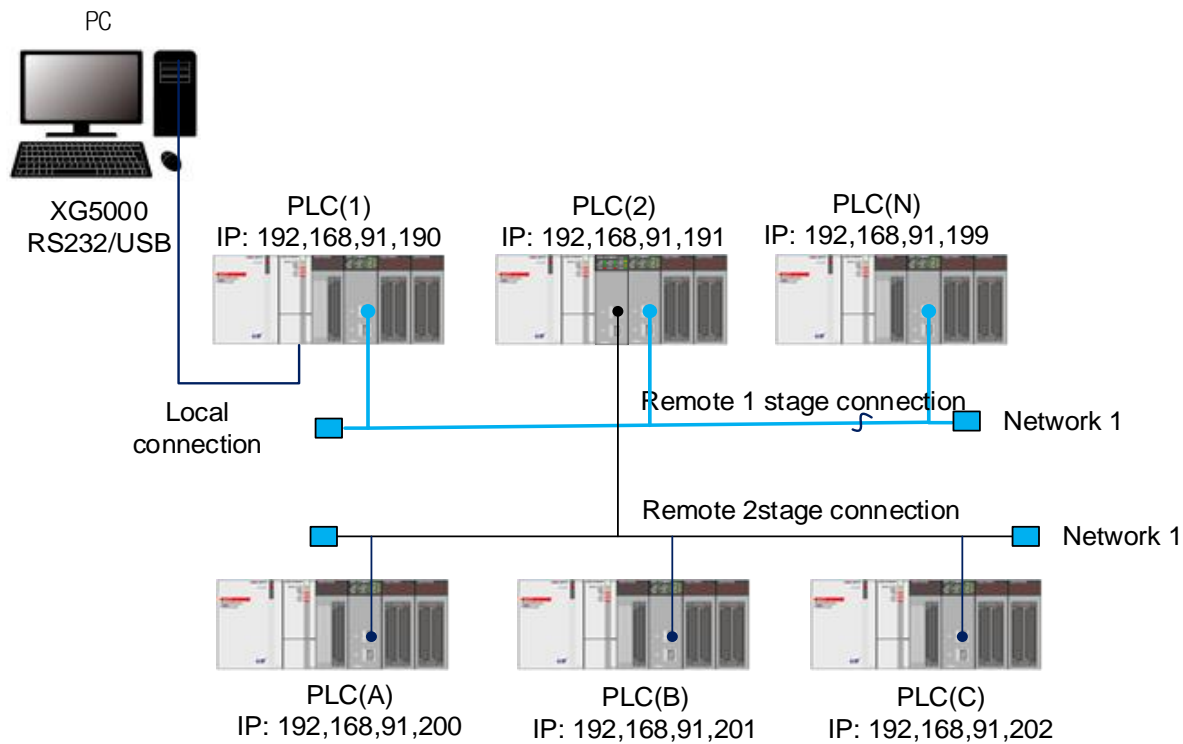

In XG5000, USB cable is connected to PLC (1) and PLC (1), PLC (2) and PLC (N) are connected to each other via Ethernet. To access the contents of PLC (1) in the above figure, make the local connection from the online menu of XG5000 and access the contents of PLC (1). After the connection is terminated, disconnect the PLC (1) disconnection menu to connect with PLC (N). after that, select PLC (N) (Ethernet module slot of PLC (1): 1) in the remote connection of the online menu to establish a connection, and the connection is established by USB and Ethernet. This status supports all the functions that can be done in PLC (1), such as creating, downloading, debugging, and monitoring programs, just as a USB cable is connected to PLC (N). In addition, if the Ethernet module is installed on the PC where the XG5000 is operating and connected to the same network as the PLC, remote 1 connection is possible with the PLC via Ethernet without going through the local connection via RS-232C.

## 8.2 XG5000 setting and connection

All PLCs connected to XGT network can be connected by XG5000 communication service. The remote connection of the XG5000 consists of the 1-stage connection and the 2-stage connection, The following describes how to connect remote stage 1 and stage 2.

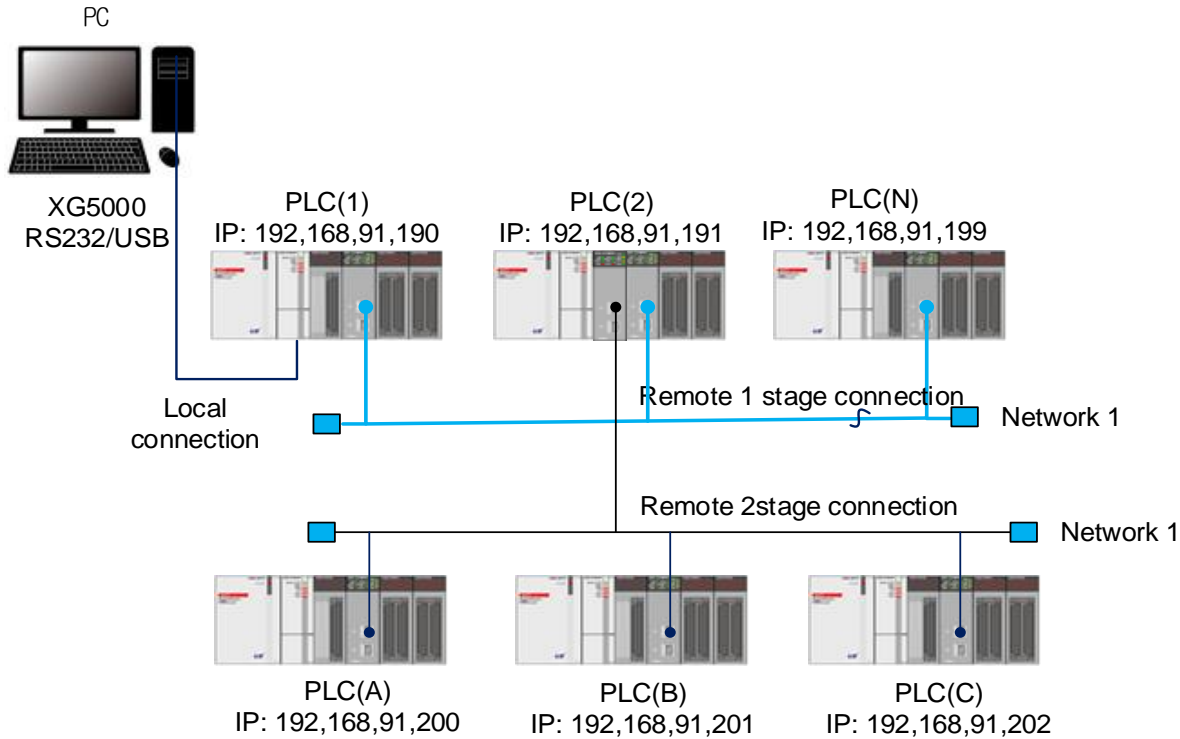

The figure above shows an example of connecting the 1st PLC (2) and 2nd PLC (B) in a system consisting of two networks.

### 8.2.1 Remote 1-stage connection (when using USB)

XG5000 must be offline for remote 1 connection. From this menu, select [Online]-> [Connection Settings].

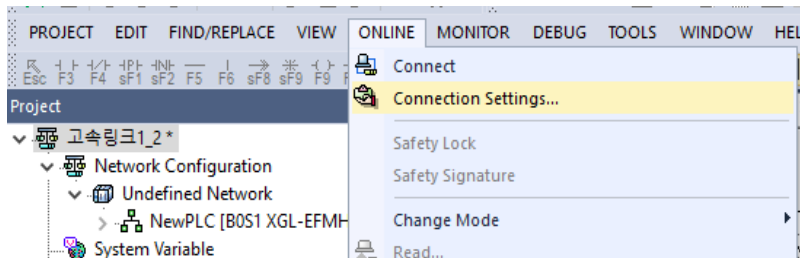

#### (1) Connection setting

- 1) Method: Select a local connection method. In the figure below, we are using a USB connection to local.
- 2) Step: In connection step, it decides whether to connect with PLC to local, remote 1 or remote 2. Select remote stage 1.

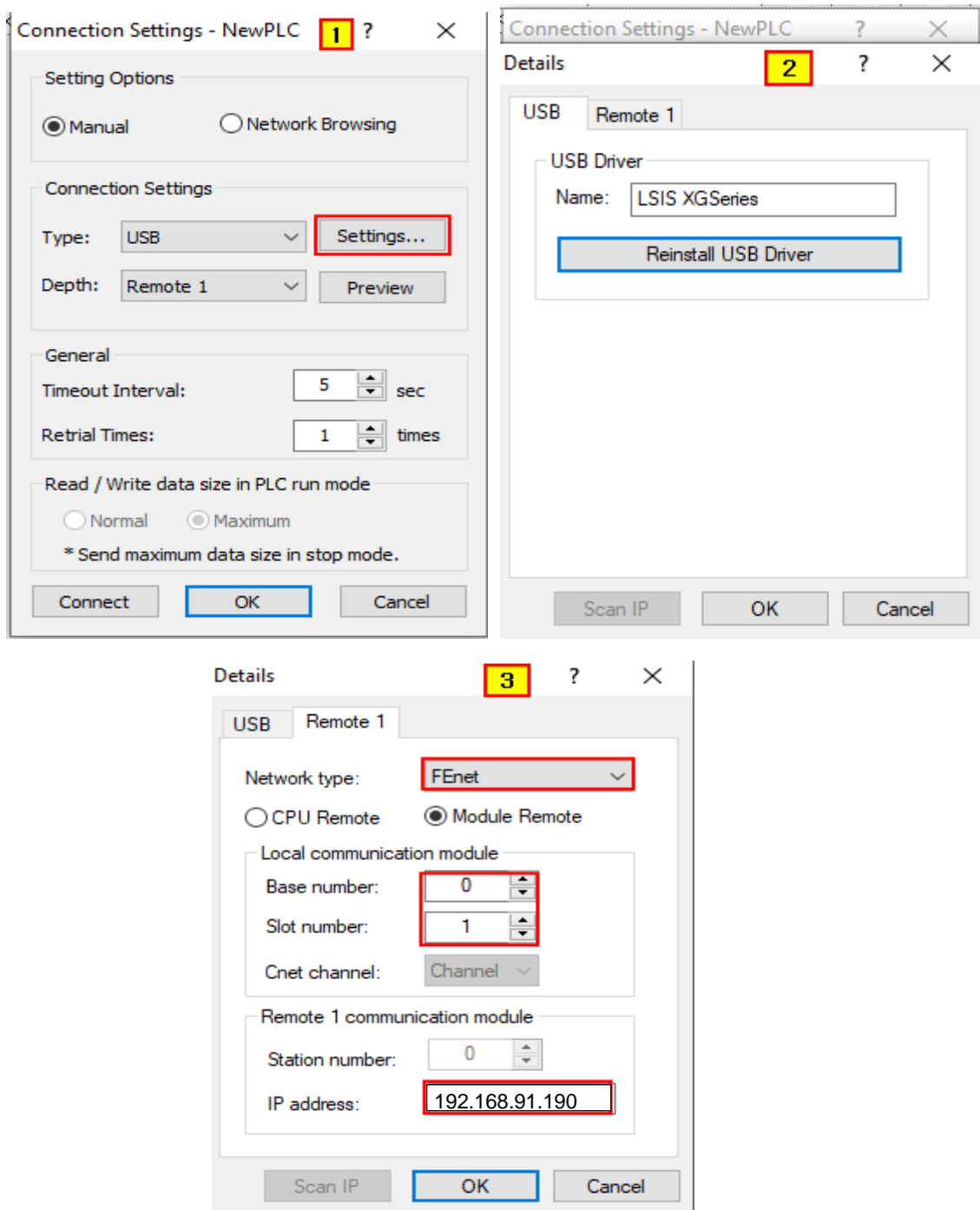

(2) Settings (Details) \_USB

- 1) USB driver: Set to LSIS XGT Series.

(3) Settings (Details) \_Remode 1

- 1) Network type: Select Rnet, Fdnet, Cnet, FEnet, FDEnet, etc. according to the network type to which step 1 connection is made. Step 1 connection is selected by Ethernet (FEnet).

Also selects an Ethernet connection between the CPU built-in Ethernet / Ethernet module.

- 2) base, slot number: Designate number of base and slot where local Ethernet module(USB connected PLC) for remote connection is installed.

3) IP address: Specify the IP address of the Ethernet module mounted in the PLC of the destination station (PLC (2)) to be connected with network 1 in network 1. Connect to the Ethernet module with the IP address 192.168.91.191.

The stage 1 connection is completed is the same logical connection state as the local connection. Therefore, all functions of the online menu can be used. (except when the CPU type of the PLC and the currently open project is not correct)

**Notes**

**Cautions for remote connection**

Create a program that matches the CPU type of the other party to connect remotely and connect. If the CPU type is not correct, only limited functions are available and the upload, download and monitoring function functions of the program are not supported.

**8.2.2 Remote 2-stage connection (when using USB)**

(1) XG5000 must be offline for remote 2 connection. In this state, select [Online]-> [Connection settings] from main menu.

(2) Connection setting

1) Method: Select a local connection method. In the figure below, we are using a USB connection to local.

2) Step: In connection step, it decides whether to connect with PLC to local, remote 1 or remote 2. Select remote stage 2.

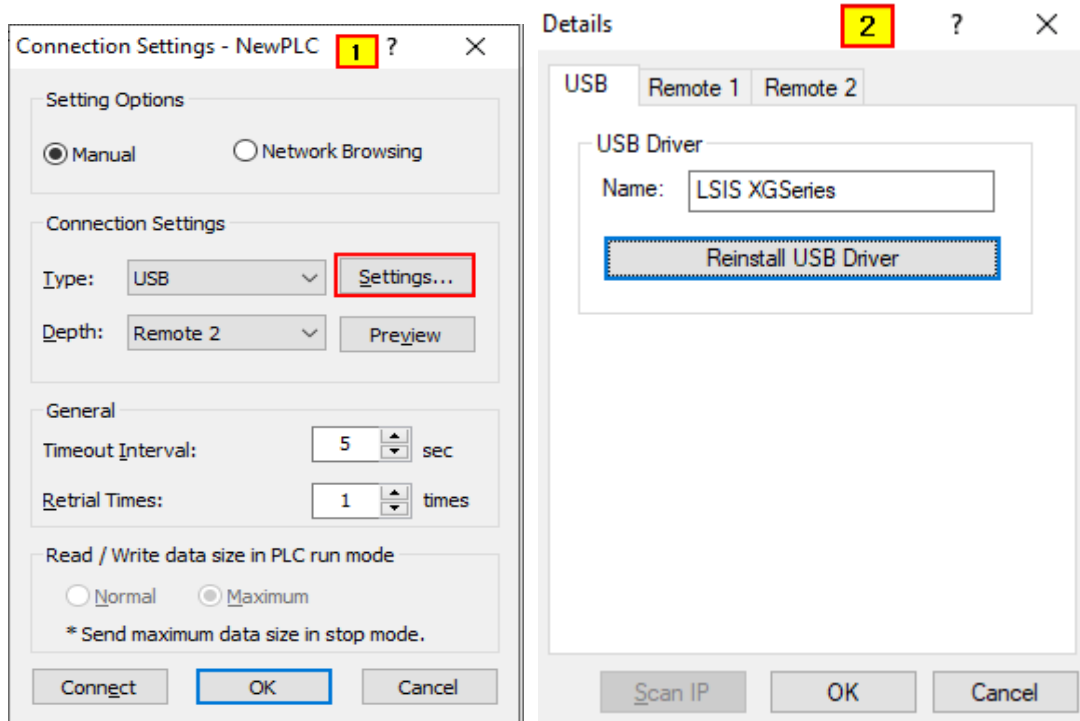

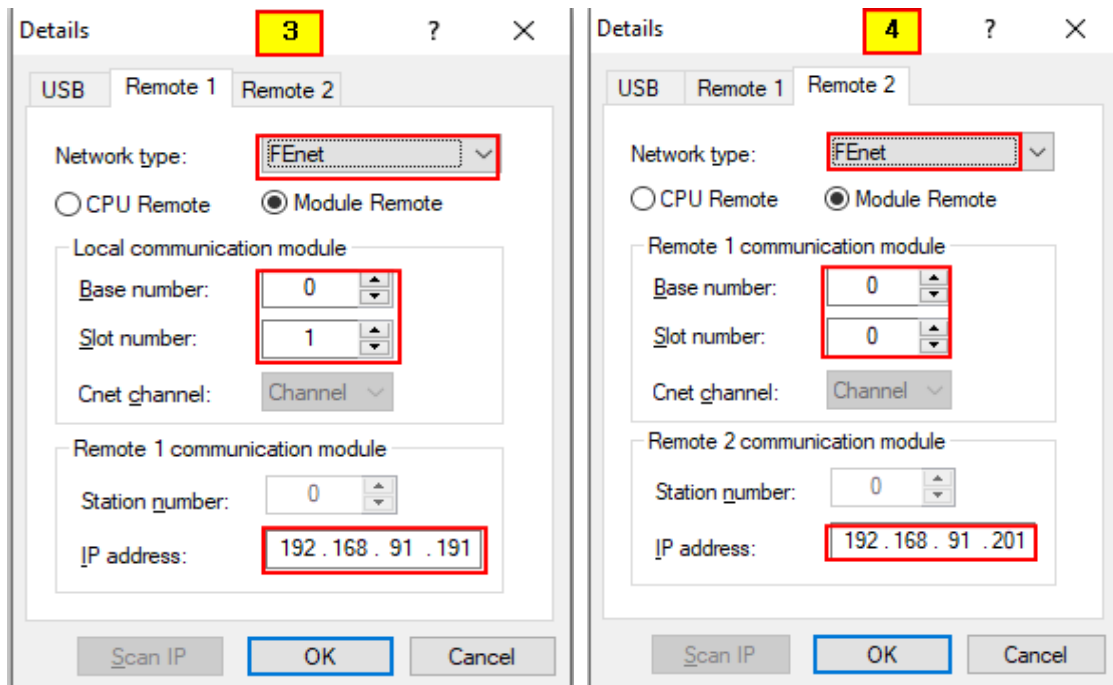

(3) Details\_Remote 1(Remote 1 setting is same as “8.2.1 Remote 1 connection”.)

(4) Details\_Remote 2

- 1) Network type: Select Rnet, Fdnet, Cnet, FEnet, FDEnet, etc. according to the network type to which step 2 connection is made. The network types of the 1st and 2nd connection are not related. It is connected by 1-stage Ethernet to FEnet.
- 2) Base, slot number: Write the base and slot number of the Ethernet module mounted on the remote 2 connected PLC.(Remote 1 stage)
- 3) Station number setting : Write the station number of the remote 2 connected module.

8.2.3 CPU access directly from PC connected to Ethernet

If the PC running XG5000 is connected to PLC by network, you can connect to CPU with remote 1 by Ethernet without connecting to PLC CPU by USB or RS-232C

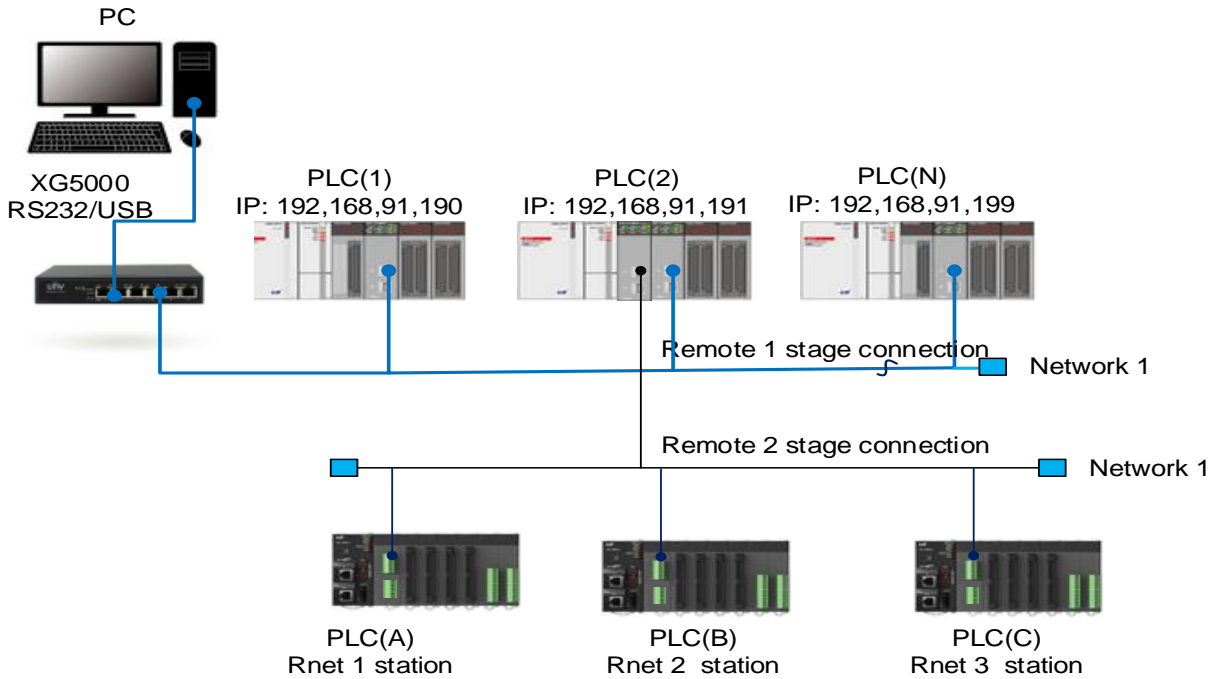

(5) Remote 1-stage connection(when using Ethernet )

The above figure shows the case where PC and PLC are connected by Ethernet. In this case, XG5000 can connect to all PLCs on network without using USB or RS-232C. In this case, local connection is omitted and all PLCs are connected to remote stage 1 and CPU. In Connect and if connect remote 1 directly via Ethernet, select connection setting and set as below dialog box.

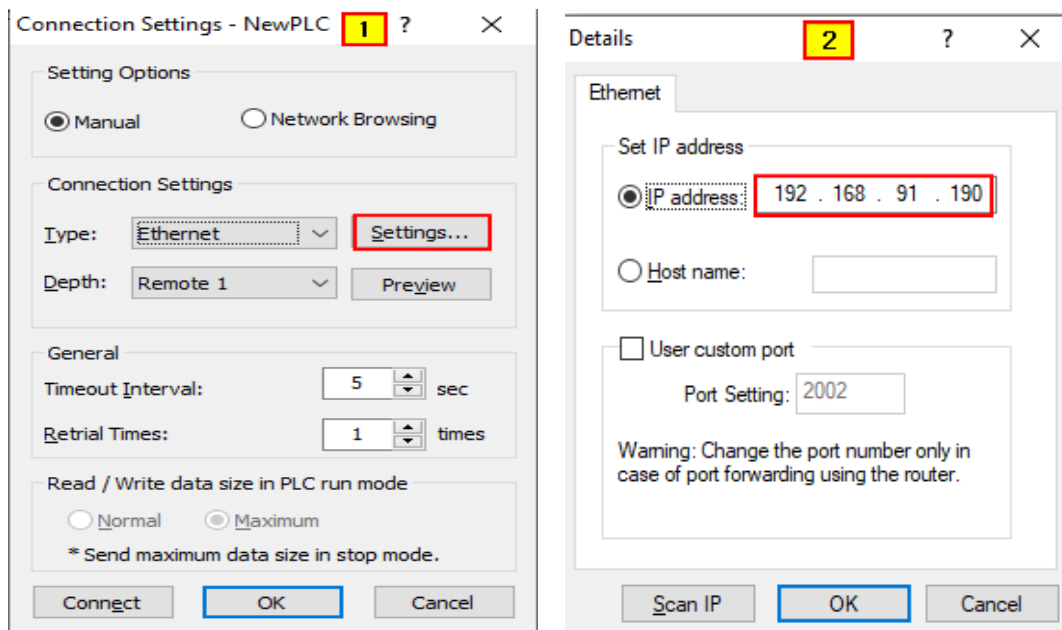

### 1) Connection method:

Select how the connection will be made. Select Ethernet because it connects to Ethernet without using RS-232C.

### 2) Connection stage:

Decide whether to establish the connection to the PLC in either remote 1-stage or remote 2-stage. Select remote stage 1.

### 3) IP address:

In the above the figure, the connection to the PLC (1), the Ethernet module with IP address 192.168.91.190, is taken as an example.

All subsequent steps are the same as when using RS-232C. Select OK in this state and select Connection from the online menu. The connection with the built-in Ethernet is the same as that of the Ethernet module.

### (6) Remote 2-stage connection(when using Ethernet )

If the PC running XG5000 is connected to PLC via network, the setting example of remote 1 connection to Ethernet and PLC (A) Rnet station 1 to remote 2 are as follows.

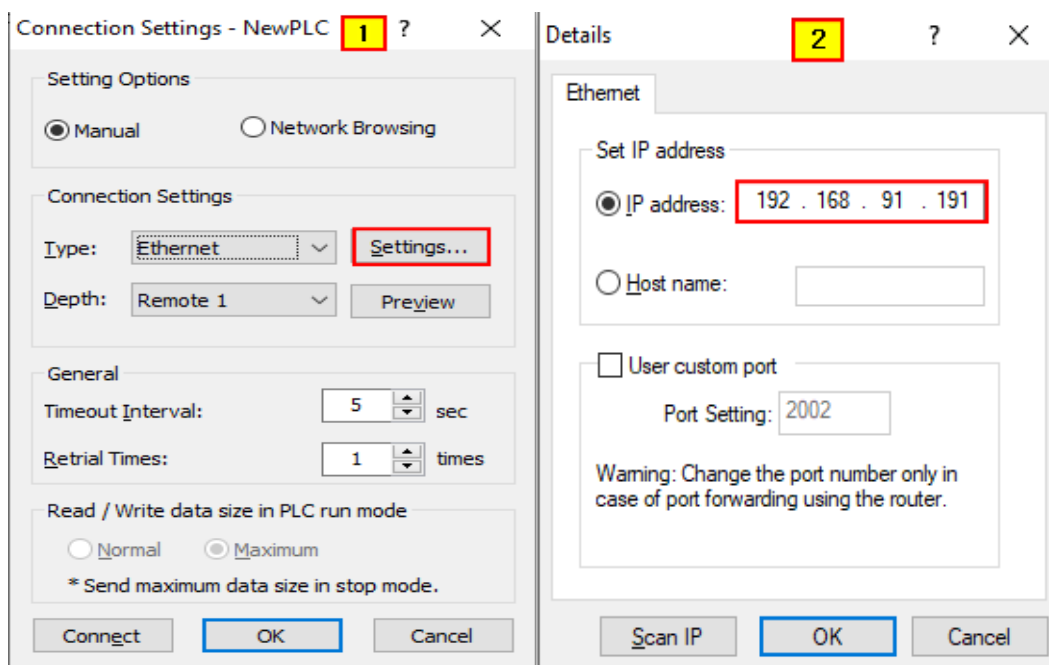

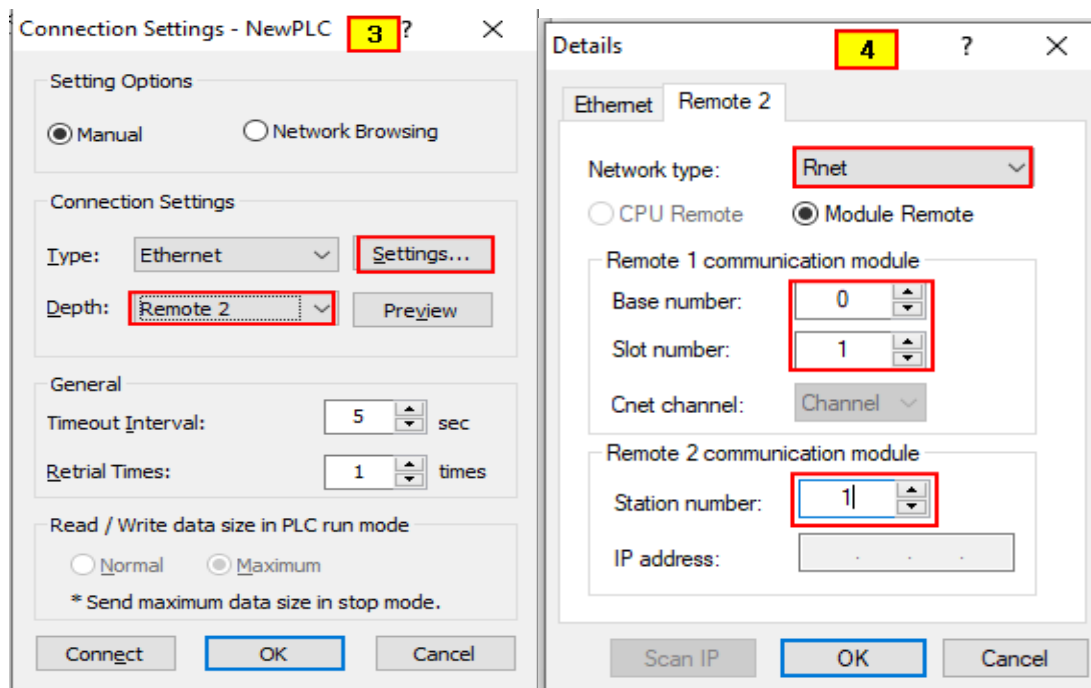

- 1) Method: Select a local connection method. Remote connection via Ethernet.
- 2) Step: Remote 1 stage is set same as "Remote 1 stage connection". Set remote 2 to set Rnet station 1.
- 3) Station address: In order to connect to PLC (A), set base and slot number of remote 1 Ethernet and input station number of Rnet 1 station in remote 2 communication module.

#### Notes

(1) Cautions when working with remote stage 1/2

1) If the currently open project on XG5000 and CPU type connected in 1st and 2nd stage do not match, the following menu items cannot be used.

- a) Write the program and each parameter
- b) Read the program and each parameter
- c) Monitor
- d) Flash memory
- e) Set link permission
- f) I/O information
- g) Forced I/O information
- h) I/O SKIP

2) When programming XG5000 by connecting remote 1 and 2, open the project of the station to be connected and execute remote connection.

3) Remote connection is only supported up to 2 levels. No further remote connection is possible.

(2) Remote connection via XGR redundancy

The same service is supported even when remotely connecting to a dual system. However, in case of connecting by master or standby, the connection path must be connected to the master CPU to transmit and receive data.

### 8.3 System configuration using switch module

Communication with host system, existing PLC system and other controllers can be done by using Ethernet communication module. XGT PLC can be configured with high speed and reliability by using Ethernet module.

#### 8.3.1 Ethernet, RAPIenet mixed system configuration (supported by Ethernet V8.0 or higher, switch V2.0 or higher)

##### (7) RAPIenet communication using standalone MRS

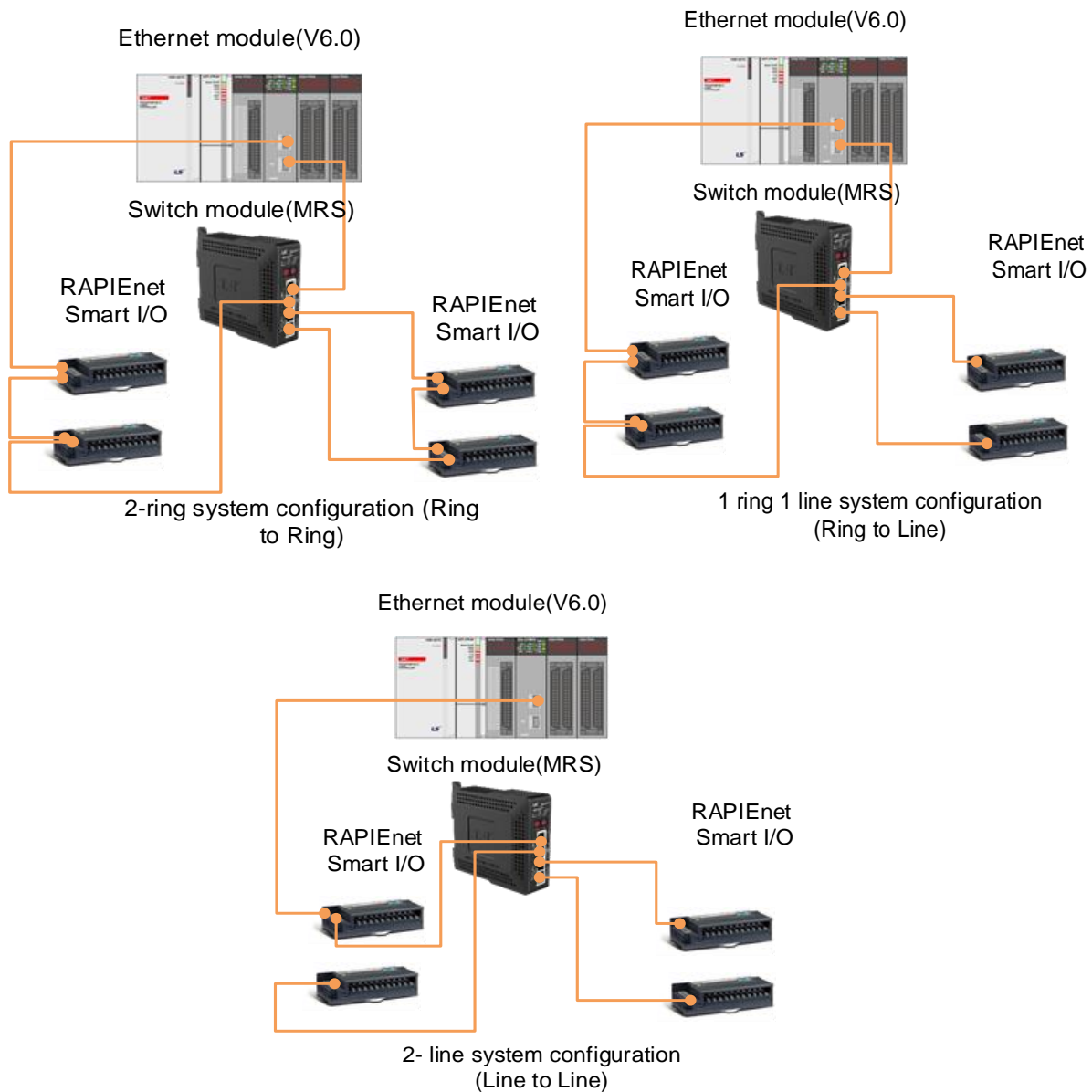

(8) RAPIEnet and Ethernet communication using MRS

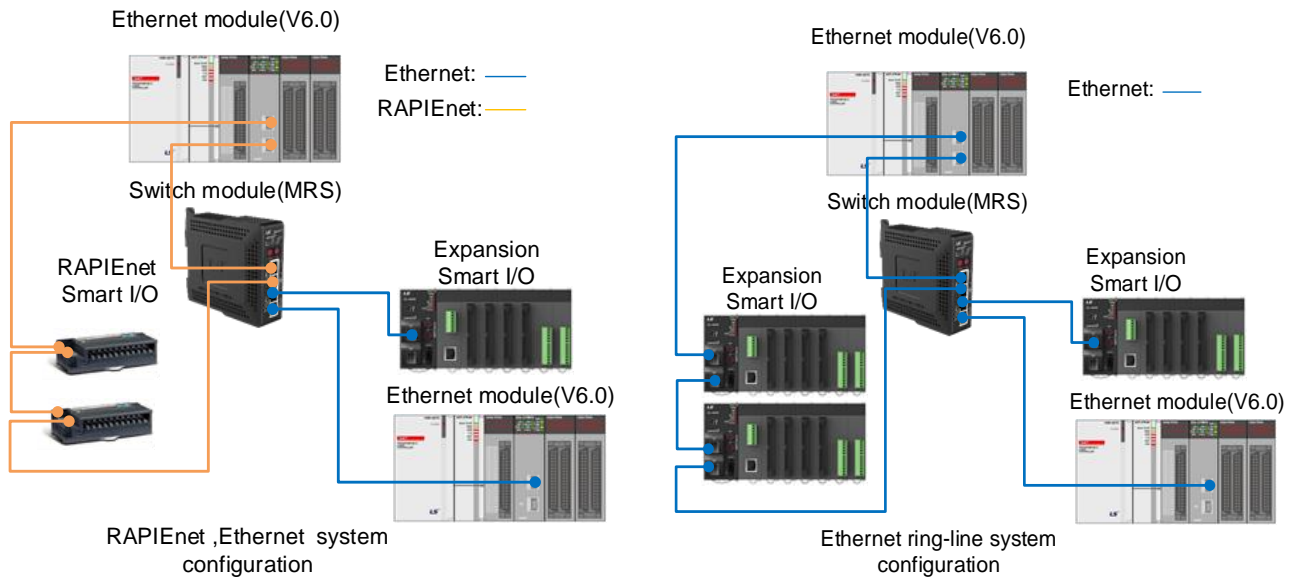

Use either Ethernet or PAPIEnet among the four switch modules.

Notes

(1) Smart extension service can be used in various system configurations. However, if 1Gbps and 100Mbps media are mixed in the system, it operates at 100Mbps. In the case of optical media, and optical media should be installed in accordance with the transceiver.

## 8.4 Communication module object data send and receive function

This function is to send/receive object data of communication module. In order to use it, please refer to the supported version information below and apply it to the system.

(1) Supported S/W version information

No.	XGL-EFMxB Version	Object ID	Description
1	V8.50	1	SNTP
2	V8.50	2	Smart Extension
3	V8.50	3	P2P
4	V8.60	4	Diagnosis

No.	CPU Type	CPU Version
1	XGI-CPUUN	V1.80
2	XGK-CPUHN	V1.80
3	XGK-CPUSN	V1.80
4	XGK-CPUUN	V1.80

(2) Command: CP\_MSG

No.	XGL-EFMxB Version	XG5000 Version	CP_MSG Function	Description
1	V8.50	V4.61	Communication module object read communication module object write Communication module object write ,read	Access to Local object(SNTP, Smart extension, P2P)
2	V8.60	V4.70	Read remote communication module object Write remote communication module object	Communication module object access of smart extension slave

For detailed instruction usage, refer to “XGK / XGB instruction user manual” or “XGI/XGR/XEC/XMC instruction user manual”.

8.4.1 SNTP object

The structure of the SNTP object (Object ID :1) is as follows.

SNTP Object | (Object ID : 1)

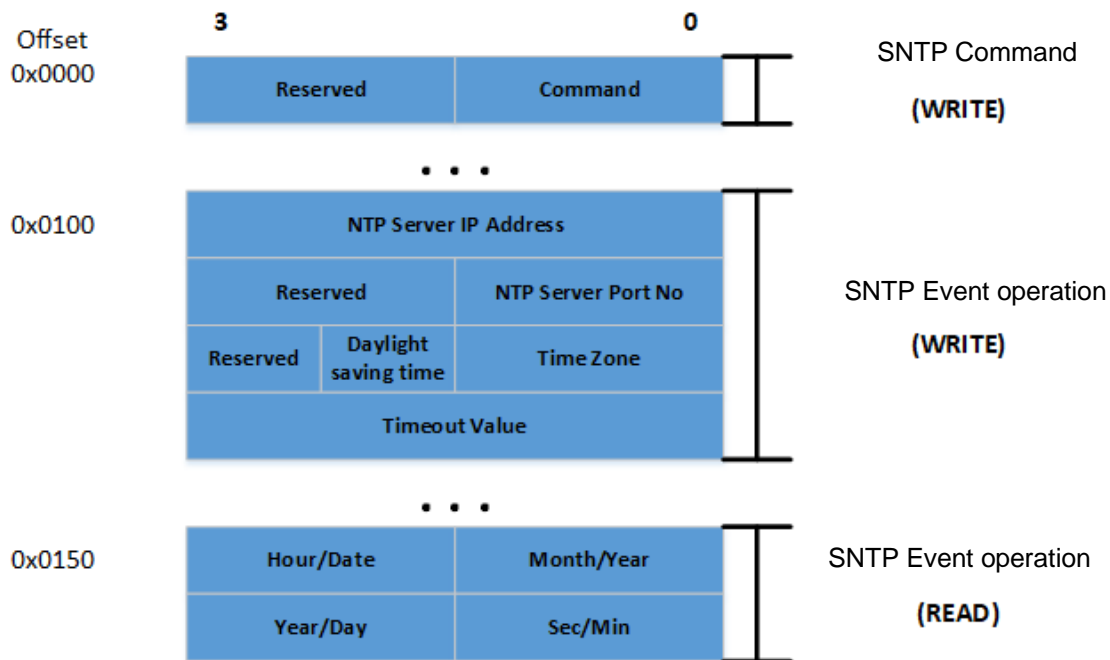

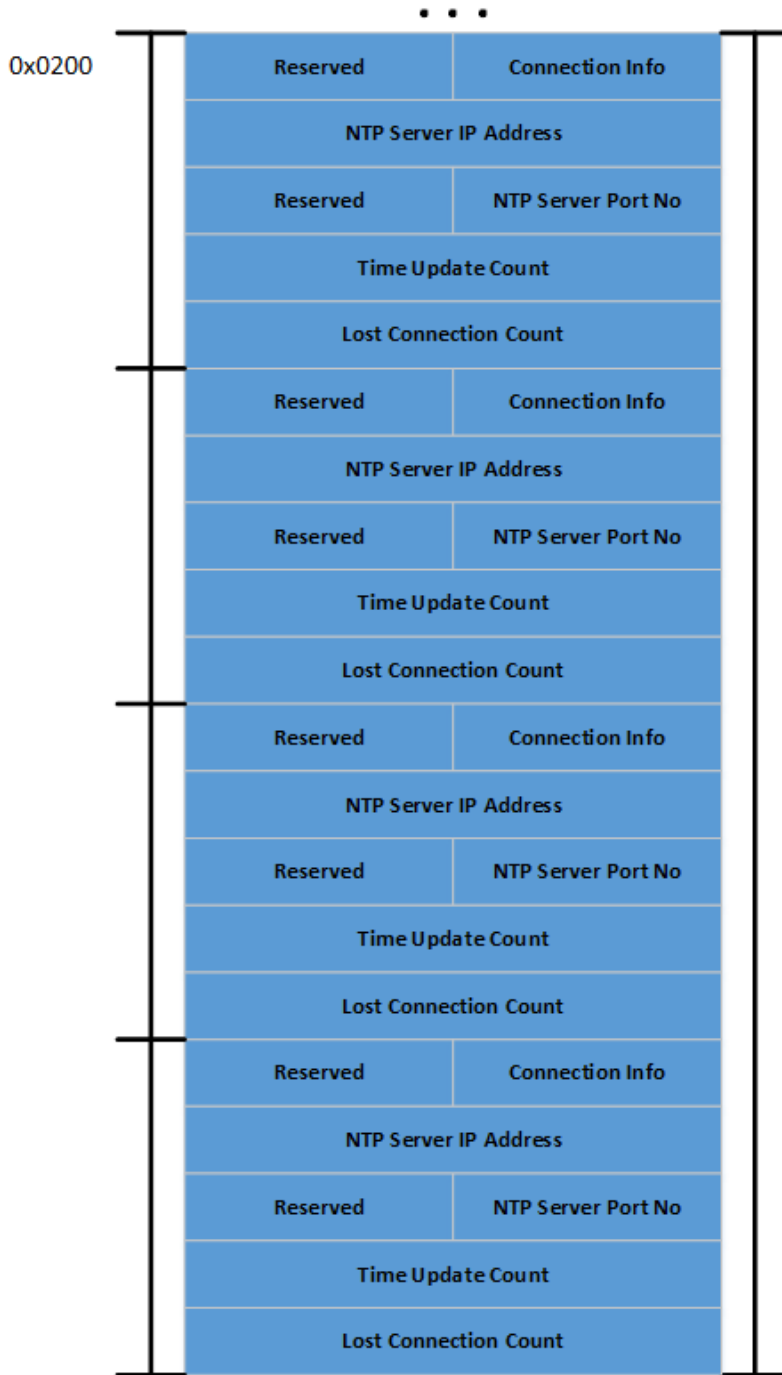

Periodic SNTP diagnostic Information (Read)

- Since there are a maximum of 4 servers that can be registered, the response structure is also 4

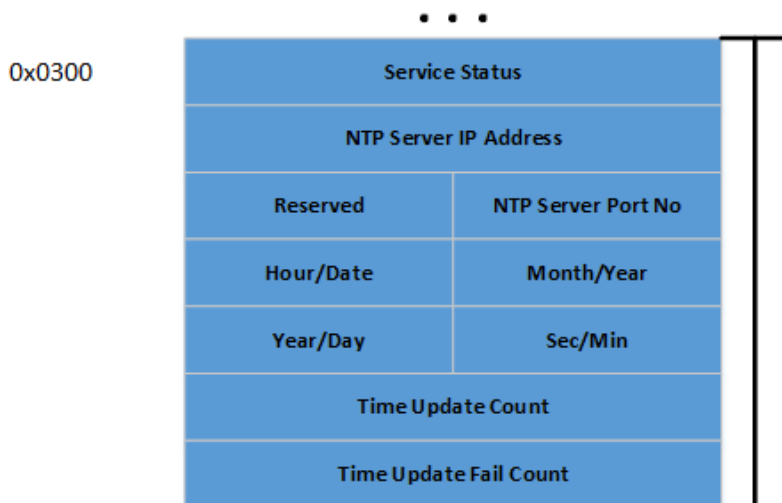

Event SNTP diagnostic information (Read)

(1) SNTP command using CP\_MSG

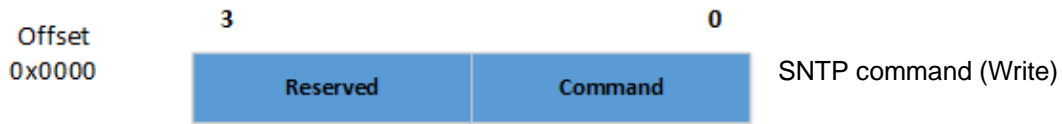

- Write control command to SNTP command offset (0x0000)
- Message structure: Command : SNTP control command

No.	Command	Description
1	0x0010	SNTP diagnostic count clear command
2	0x0020	SNTP Event diagnostic count clear command

- CP\_MSG SNTP Command WRITE Request Message Structure

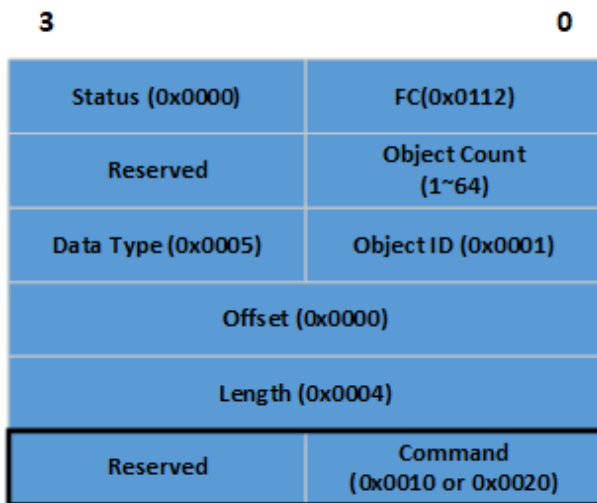

- Ladder program writing example
- : SNTP diagnostic count clear command

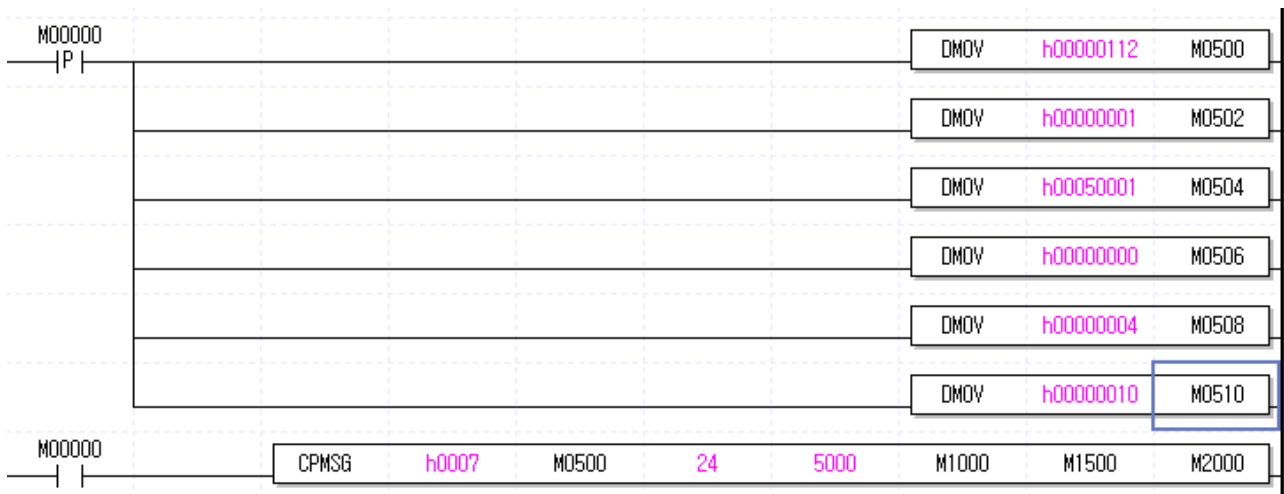

: SNTP Event diagnostic count clear command

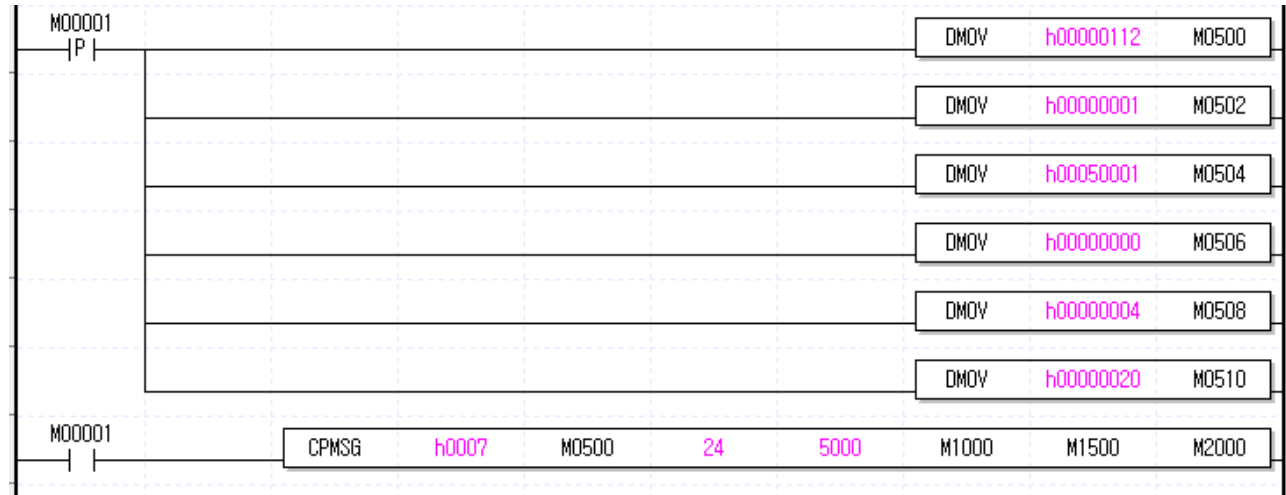

(2) SNTP Event operating for using CP\_MSG

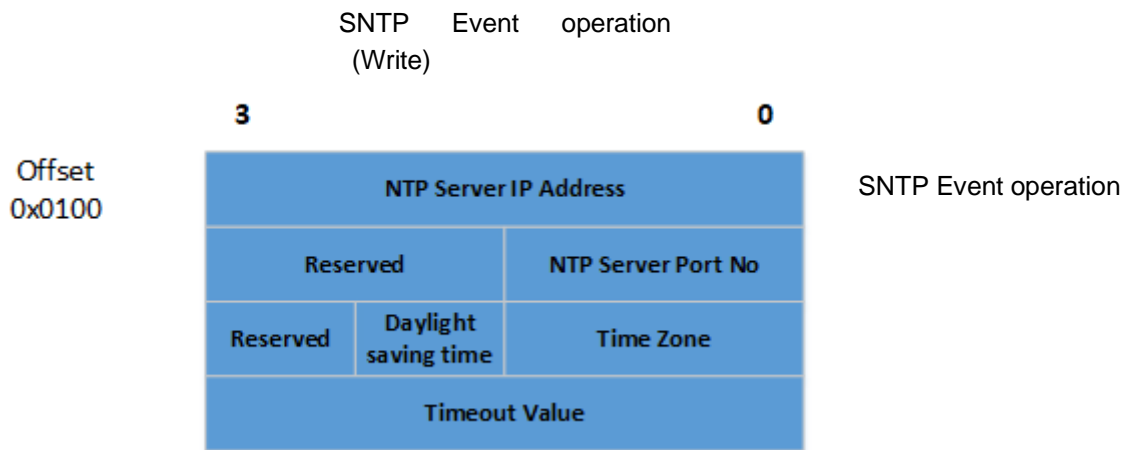

- Write control command to SNTP event operation command offset (0x0100)
- Message structure
- : NTP Server IP Address: IP address of NTP Server for SNTP event operation
- : NTP Server Port No: Port address of NTP Server for SNTP event operation
- ==> If the NTP server port is not changed, the port address is 123.
- : Time Zone: Time Zone setting for SNTP operation
- ==> Convert the time zone value for each country that the user wants to set into minutes and input
- ex1) Korea time zone is +9 hours, so  $9 \times 60 = 540$ .
- ex1) US time zone is -5 hours, so  $(-5) \times 60 = -300$
- ==> See table below

No.	Time zone (UTC ± time)	convert to minutes
1	(UTC-12:00) International Date Line West	-12:00 * 60 = -720
2	(UTC-11:00) Samoa	-11:00 * 60 = -660
3	(UTC-10:00) Hawaii	-10:00 * 60 = -600
4	(UTC-09:00) Alaska	-09:00 * 60 = -540
5	(UTC-08:00) Baja California	-08:00 * 60 = -480
6	(UTC-08:00) Pacific Time (US & Canada)	-08:00 * 60 = -480
7	(UTC-07:00) Arizona	-07:00 * 60 = -420
8	(UTC-07:00) Chihuahua, La Paz, Mazatlan	-07:00 * 60 = -420
9	(UTC-07:00) Mountain Time (US & Canada)	-07:00 * 60 = -420
10	(UTC-06:00) Central America	-06:00 * 60 = -360
11	(UTC-06:00) Central Time (US & Canada)	-06:00 * 60 = -360
12	(UTC-06:00) Guadalajara, Mexico City, Monterrey	-06:00 * 60 = -360
13	(UTC-06:00) Saskatchewan	-06:00 * 60 = -360
14	(UTC-05:00) Bogota, Lima, Quito	-05:00 * 60 = -300
15	(UTC-05:00) Eastern Time (US & Canada)	-05:00 * 60 = -300
16	(UTC-05:00) Indiana (East)	-05:00 * 60 = -300
17	(UTC-04:30) Caracas	-04:30 * 60 = -270
18	(UTC-04:00) Asuncion	-04:00 * 60 = -240
19	(UTC-04:00) Atlantic Time (Canada)	-04:00 * 60 = -240
20	(UTC-04:00) Cuiaba	-04:00 * 60 = -240
21	(UTC-04:00) Georgetown, La Paz, Manaus, San Juan	-04:00 * 60 = -240
22	(UTC-04:00) Santiago	-04:00 * 60 = -240
23	(UTC-03:30) Newfoundland	-03:30 * 60 = -210
24	(UTC-03:00) Brasilia	-03:00 * 60 = -180
25	(UTC-03:00) Buenos Aires	-03:00 * 60 = -180
26	(UTC-03:00) Cayenne, Fortaleza	-03:00 * 60 = -180
27	(UTC-03:00) Greenland	-03:00 * 60 = -180

## Chapter 8 Additional functions

28	(UTC-03:00) Montevideo	-03:00 * 60 = -180
29	(UTC-02:00) Coordinated Universal Time-02	-02:00 * 60 = -120
30	(UTC-02:00) Mid-Atlantic	-02:00 * 60 = -120
31	(UTC-01:00) Azores	-01:00 * 60 = -60
32	(UTC-01:00) Cape Verde Is.	-01:00 * 60 = -60
33	(UTC) Casablanca	12:00 AM * 60 = 0
34	(UTC) Coordinated Universal Time	12:00 AM * 60 = 0
35	(UTC) Dublin, Edinburgh, Lisbon, London	12:00 AM * 60 = 0
36	(UTC) Monrovia, Reykjavik	12:00 AM * 60 = 0
37	(UTC+01:00) Amsterdam, Berlin, Bern, Rome, Stockholm, Vienna	01:00 * 60 = 60
38	(UTC+01:00) Belgrade, Bratislava, Budapest, Ljubljana, Prague	1:00 AM * 60 = 60
39	(UTC+01:00) Brussels, Copenhagen, Madrid, Paris	1:00 AM * 60 = 60
40	(UTC+01:00) Sarajevo, Skopje, Warsaw, Zagreb	1:00 AM * 60 = 60
41	(UTC+01:00) West Central Africa	1:00 AM * 60 = 60
42	(UTC+02:00) Amman	2:00 AM * 60 = 120
43	(UTC+02:00) Athens, Bucharest, Istanbul	2:00 AM * 60 = 120
44	(UTC+02:00) Beirut	2:00 AM * 60 = 120
45	(UTC+02:00) Cairo	2:00 AM * 60 = 120
46	(UTC+02:00) Damascus	2:00 AM * 60 = 120
47	(UTC+02:00) Harare, Pretoria	2:00 AM * 60 = 120
48	(UTC+02:00) Helsinki, Kyiv, Riga, Sofia, Tallinn, Vilnius	2:00 AM * 60 = 120
49	(UTC+02:00) Jerusalem	2:00 AM * 60 = 120
50	(UTC+02:00) Minsk	2:00 AM * 60 = 120
51	(UTC+02:00) Windhoek	2:00 AM * 60 = 120
52	(UTC+03:00) Baghdad	3:00 AM * 60 = 180
53	(UTC+03:00) Kuwait, Riyadh	3:00 AM * 60 = 180
54	(UTC+03:00) Moscow, St. Petersburg, Volgograd	3:00 AM * 60 = 180
55	(UTC+03:00) Nairobi	3:00 AM * 60 = 180

56	(UTC+03:30) Tehran	3:30 AM * 60 = 210
57	(UTC+04:00) Abu Dhabi, Muscat	4:00 AM * 60 = 240
58	(UTC+04:00) Baku	4:00 AM * 60 = 240
59	(UTC+04:00) Port Louis	4:00 AM * 60 = 240
60	(UTC+04:00) Tbilisi	4:00 AM * 60 = 240
61	(UTC+04:00) Yerevan	4:00 AM * 60 = 240
62	(UTC+04:30) Kabul	4:30 AM * 60 = 270
63	(UTC+05:00) Ekaterinburg	5:00 AM * 60 = 300
64	(UTC+05:00) Islamabad, Karachi	5:00 AM * 60 = 300
65	(UTC+05:00) Tashkent	5:00 AM * 60 = 300
66	(UTC+05:30) Chennai, Kolkata, Mumbai, New Delhi	5:30 AM * 60 = 330
67	(UTC+05:30) Sri Jayawardenepura	5:30 AM * 60 = 330
68	(UTC+05:45) Kathmandu	5:45 AM * 60 = 345
69	(UTC+06:00) Astana	6:00 AM * 60 = 360
70	(UTC+06:00) Dhaka	6:00 AM * 60 = 360
71	(UTC+06:00) Novosibirsk	6:00 AM * 60 = 360
72	(UTC+06:30) Yangon (Rangoon)	6:30 AM * 60 = 390
73	(UTC+07:00) Bangkok, Hanoi, Jakarta	7:00 AM * 60 = 420
74	(UTC+07:00) Krasnoyarsk	7:00 AM * 60 = 420
75	(UTC+08:00) Beijing, Chongqing, Hong Kong, Urumqi	8:00 AM * 60 = 480
76	(UTC+08:00) Irkutsk	8:00 AM * 60 = 480
77	(UTC+08:00) Kuala Lumpur, Singapore	8:00 AM * 60 = 480
78	(UTC+08:00) Perth	8:00 AM * 60 = 480
79	(UTC+08:00) Taipei	8:00 AM * 60 = 480
80	(UTC+08:00) Ulaanbaatar	8:00 AM * 60 = 480
81	(UTC+09:00) Osaka, Sapporo, Tokyo	9:00 AM * 60 = 540
82	(UTC+09:00) Seoul	9:00 AM * 60 = 540
83	(UTC+09:00) Yakutsk	9:00 AM * 60 = 540

## Chapter 8 Additional functions

84	(UTC+09:30) Adelaide	9:30 AM * 60 = 570
85	(UTC+09:30) Darwin	9:30 AM * 60 = 570
86	(UTC+10:00) Brisbane	10:00 AM * 60 = 600
87	(UTC+10:00) Canberra, Melbourne, Sydney	10:00 AM * 60 = 600
88	(UTC+10:00) Guam, Port Moresby	10:00 AM * 60 = 600
89	(UTC+10:00) Hobart	10:00 AM * 60 = 600
90	(UTC+10:00) Vladivostok	10:00 AM * 60 = 600
91	(UTC+11:00) Magadan, Solomon Is., New Caledonia	11:00 AM * 60 = 660
92	(UTC+12:00) Auckland, Wellington	12:00 PM * 60 = 720
93	(UTC+12:00) Coordinated Universal Time+12	12:00 PM * 60 = 720
94	(UTC+12:00) Fiji	12:00 PM * 60 = 720
95	(UTC+12:00) Petropavlovsk-Kamchatsky - Old	12:00 PM * 60 = 720
96	(UTC+13:00) Nuku 'alofa	1:00 PM * 60 = 780
97	(UTC+01:00) British Summer Time	1:00 AM * 60 = 60
98	(UTC+01:00) Irish Summer Time	1:00 AM * 60 = 60
99	(UTC+01:00) Western Europe Summer Time	1:00 AM * 60 = 60
100	(UTC+02:00 ) Central Europe Summer Time	02:00 * 60 = 120
101	(UTC+03:00 ) Eastern Europe Summer Time	3:00 AM * 60 = 180
102	(UTC+04:00 ) Moscow Summer Time	04:00 * 60 = 240
103	(UTC-03:00 ) Atlantic Daylight Time	-03:00 * 60 = -180
104	(UTC-04:00 ) Eastern Daylight Time	-04:00 * 60 = -240
105	(UTC-05:00 ) Central Daylight Time	-05:00 * 60 = -300
106	(UTC-06:00 ) Mountain Daylight Time	-06:00 * 60 = -360
107	(UTC-07:00 ) Pacific Daylight Time	-07:00 * 60 = -420
108	(UTC-08:00 ) Alaska Daylight Time	-08:00 * 60 = -480
109	(UTC+10:00 ) Australian Eastern Daylight Time	10:00 AM * 60 = 600
110	(UTC+10:30 ) Australian Central Daylight Time	10:30 AM * 60 = 630

Daylight Saving Time: Daylight Saving Time setting for SNTP operation

Daylight Saving Time Disable: 0

Daylight Saving Time Enable: 1

Timeout Value: Timeout setting value until retrieval of time information from NTP server

Enter a value in ms units (10ms 65535ms)

- CP\_MSG SNTP Event operating WRITE Request Message Structure

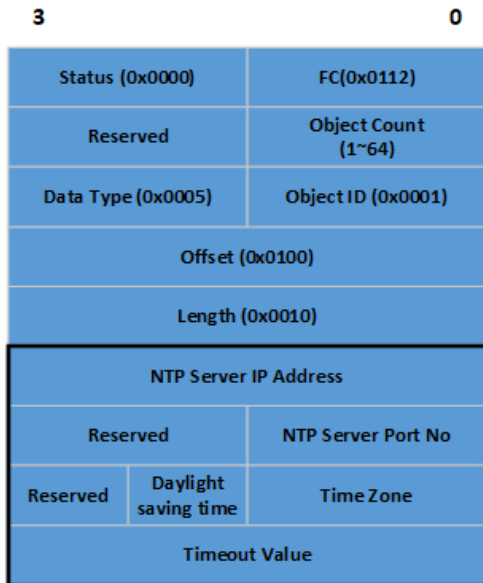

- Ladder program writing example

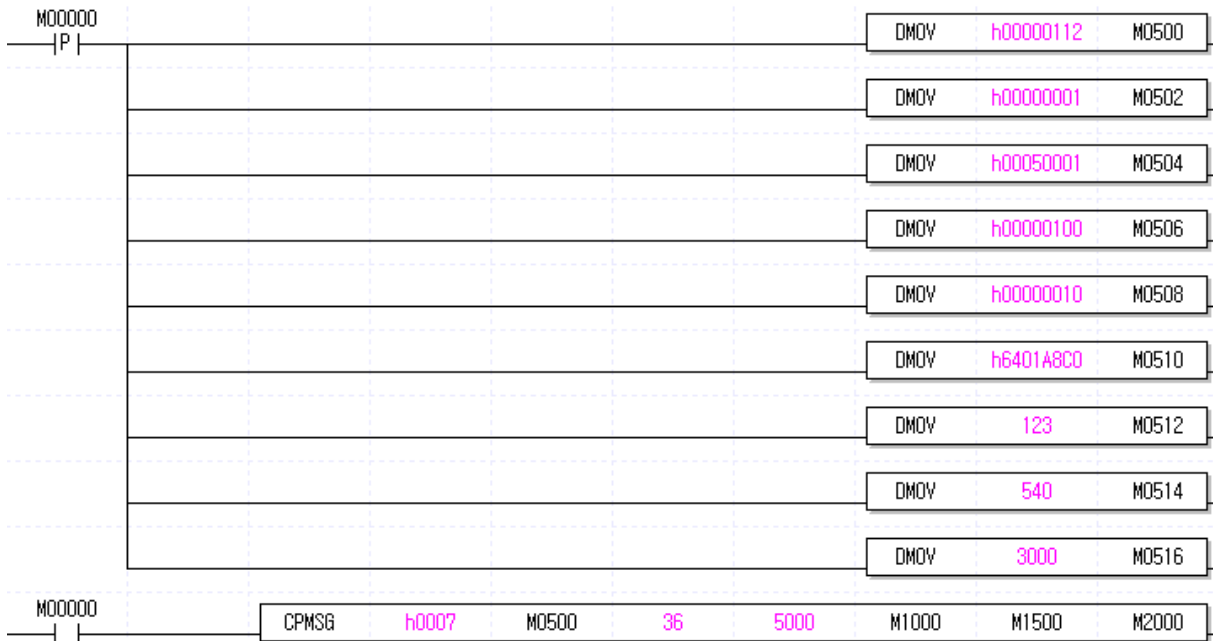

(3) Read SNTP Event operating status for using CP\_MSG

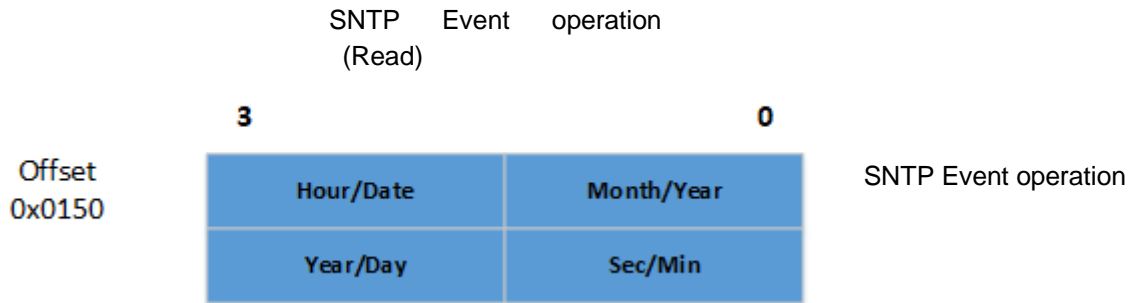

- Read SNTP event operation command offset (0x0150)
- Time information received from the NTP server through the most recent SNTP event operation
- : Month/Year: month /two digit after year (ex) 2021 --> 0x21)
- : Hour/Date
- : Sec/Min
- : Year/Day:two digit before year (ex) 2021 --> 0x20) / day of week (1 to 7 indicate Monday and Sunday)
- ex) Month/Year (Example: 2021 --> 0x21)
- Month/Year: 0x06 / 0x21
- Hour/Data: 0x14 / 0x22
- Sec/Min: 0x38 / 0x10
- Year/Day: 0x20 / 0x02

- CP\_MSG SNTP Event operating READ response Message Structure

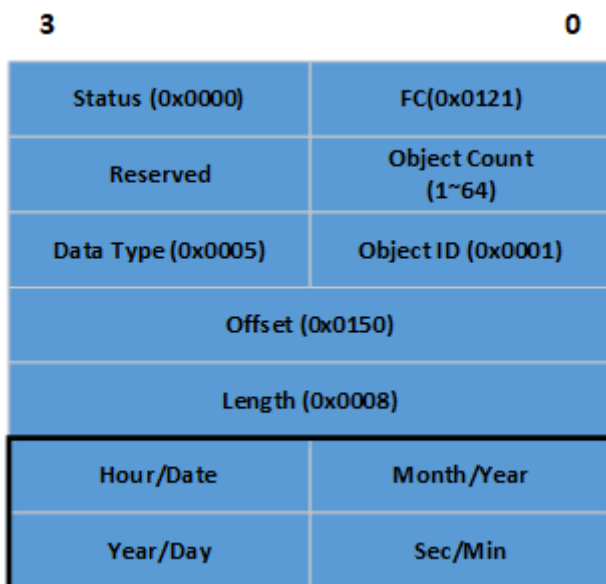

- Ladder program writing example

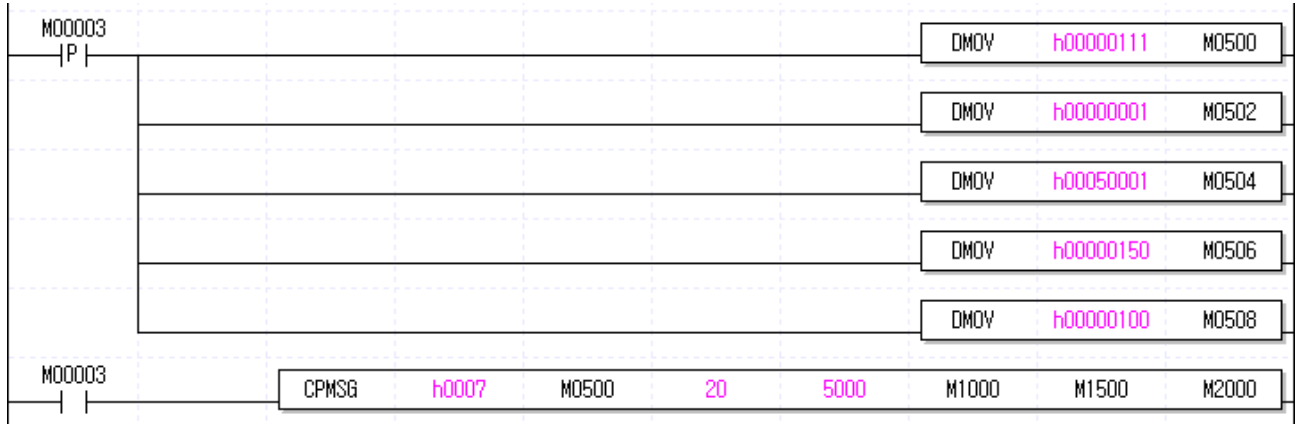

(4) Read SNTP diagnostics information for using CP\_MSG

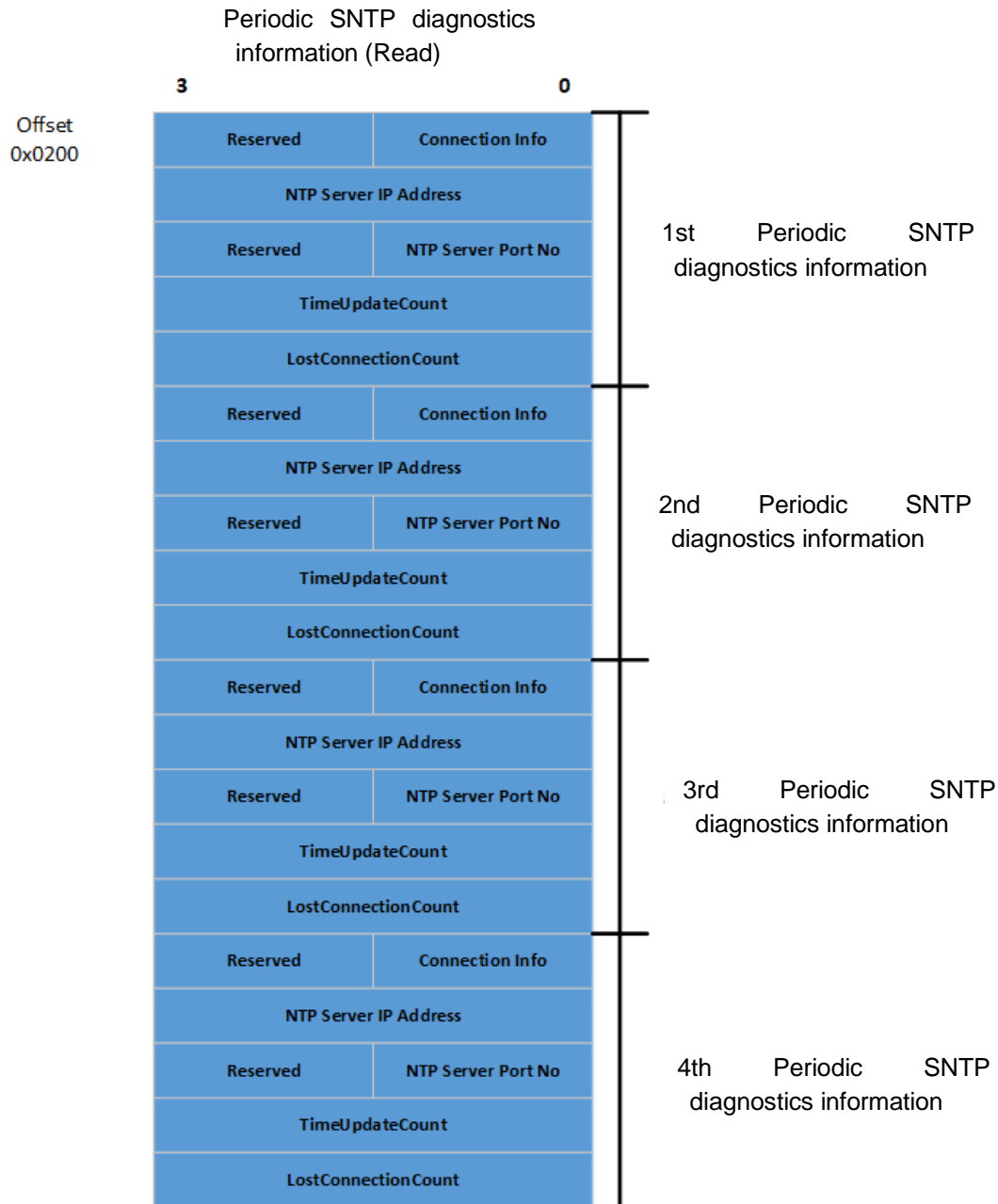

- Read Diagnostic information offset (0x0200) for periodic SNTP operation
- Message structure
- : Connection Info: Connection status with NTP server
- ==> 0: No Setting
- ==> 1: Parameter Download
- ==> 2: NTP server Connect
- ==> 3: NTP NTP server disconnection)
- : NTP Server IP Address: NTP Server IP address downloaded as parameter
- : NTP Server Port No: NTP Server port address download as parameter
- : time update Count: Count normally updated time information from NTP server
- : lost connection Count: Count disconnected from the NTP server

- CP\_MSG periodic SNTP Diagnostics READ response Message Structure

<b>3</b>	<b>0</b>
Status (0x0000)	FC(0x0121)
Reserved	Object Count (1~64)
Data Type (0x0005)	Object ID (0x0001)
Offset (0x0200)	
Length (0x0050)	
Reserved	Connection Info
NTP Server IP Address	
Reserved	NTP Server Port No
Time Update Count	
Lost Connection Count	
Reserved	Connection Info
NTP Server IP Address	
Reserved	NTP Server Port No
Time Update Count	
Lost Connection Count	
Reserved	Connection Info
NTP Server IP Address	
Reserved	NTP Server Port No
Time Update Count	
Lost Connection Count	
Reserved	Connection Info
NTP Server IP Address	
Reserved	NTP Server Port No
Time Update Count	
Lost Connection Count	

- Ladder program writing example

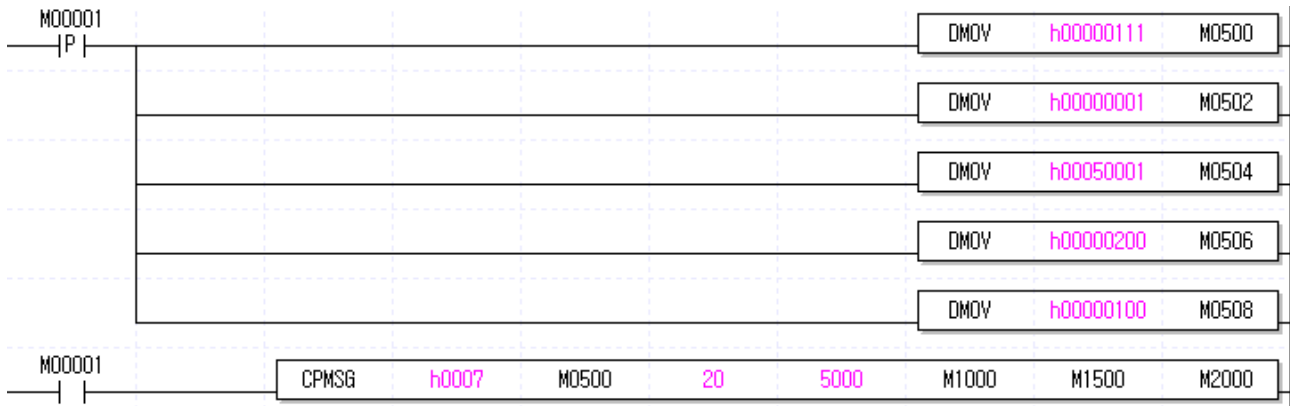

(5) Read event SNTP diagnostics information for using CP\_MSG

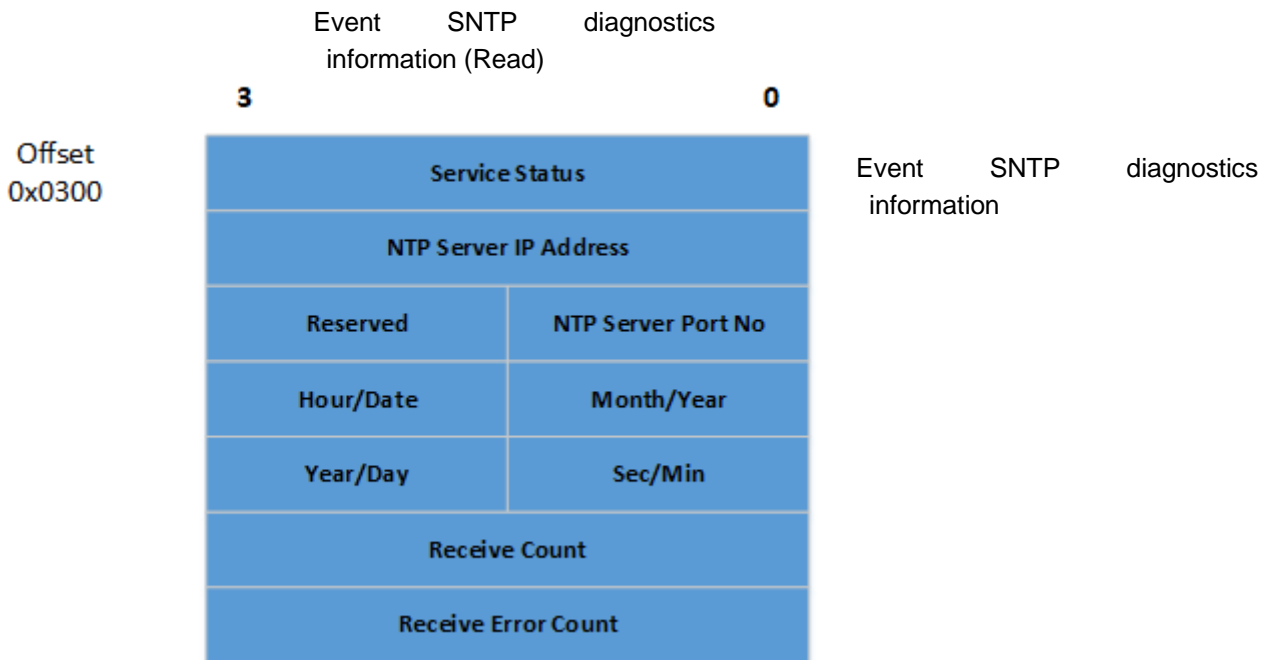

- Read Diagnostic information offset (0x0300) for periodic SNTP operation

- Message structure

: Service Status: Status of the most recently performed SNTP event action

==> 0: normal

==> For values other than 0, refer to 'List of Error Codes for SNTP Objects' below.

: NTP Server IP Address: IP address of NTP Server for recently and if SNTP event operation

: NTP Server Port No: NTP port number for the most recently performed SNTP event operation

: Month/Year, Hour/Data, Sec/Min, Year/Day: Time information received from the NTP server through the most recent SNTP event operation

==> For detailed description, refer to the above SNTP event operation READ

: Time Update Count: Count of successful update of time information with SNTP event action

: Time Update Fail Count: Count of failed SNTP event operation

- CP\_MSG event Sntp Diagnostics READ response Message Structure

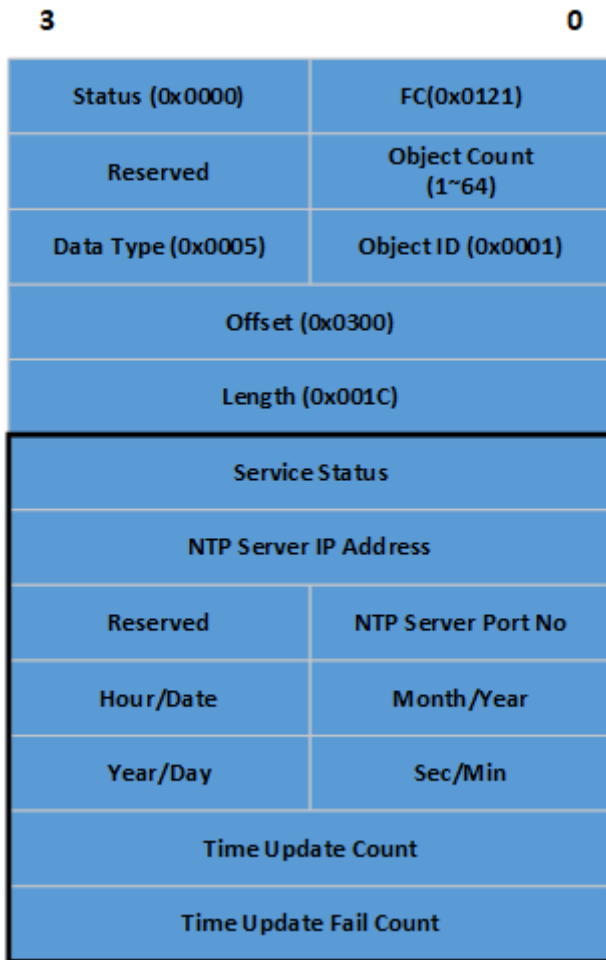

- Ladder program writing example

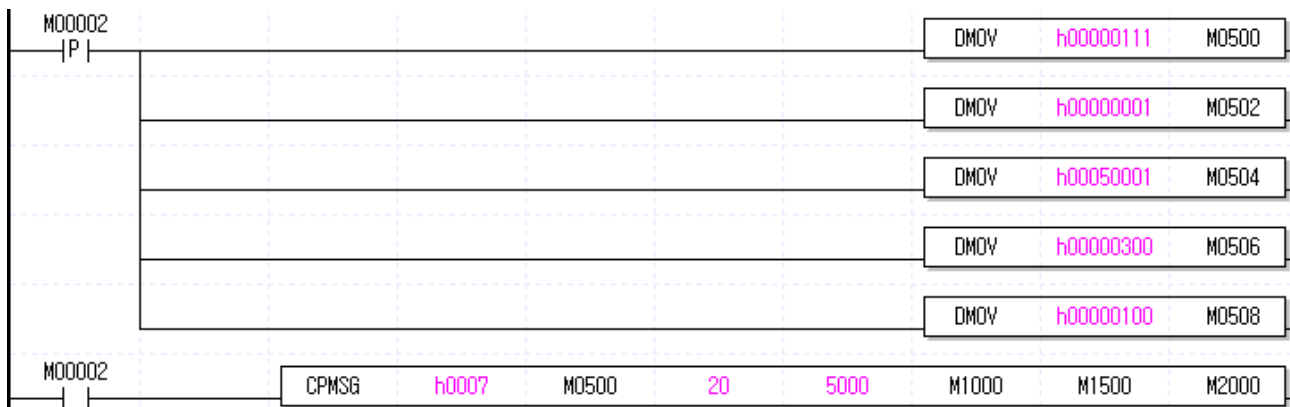

(6) refer to 'List of Error Codes for SNTP Objects' below.

No.	Error code	Description
1	0x0150	TIMEZONE setting error when writing SNTP event operation command
2	0x0151	NTP SERVER register error when writing SNTP event operation command
3	0x0152	DAYLIGHT SAVING TIME setting error when Write SNTP event operation command
4	0x0153	TIMEOUT VALUE setting error when writing SNTP event operation command
5	0x0154	COMMAND setting error when writing SNTP event operation command
6	0x0155	Error receiving time information from NTP SERVER when writing SNTP event operation command (If time information is not received during the set timeout period)
7	0x0156	When the SNTP event operation command is WRITE, the event SNTP cannot be operated because periodic SNTP is operating through the parameter.

8.4.2 Smart Extension object

The structure of the Smart Extension object (Object ID :2) is as follows.

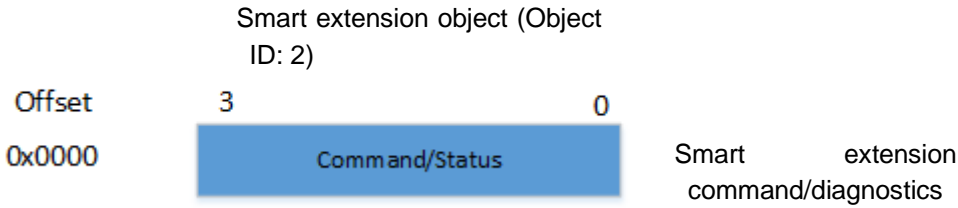

(1) Smart extension service Enable/Disable command using CP\_MSG

- Write control command to smart extension service control object offset (0x0000).
- Enable: 0x0000000E
- Disable: 0x0000000D
- An error ( UNIV\_ERR\_INVALID\_PRM ) response to an input value outside the set range of each field of the command.
- In the state of being enabled, it cannot be re-enabled.
- In the state of being disabled, it cannot be re-disabled.

Note) For safe operation of smart extension service, the Inhibit time for service Enable/Disable command is 200ms. Executing Smart Extension Service Enable/Disable CP\_MSG within 200ms returns an error.

(2) Smart extension service Enable/Disable Status read using CP\_MSG

- Read smart extension service control object offset (0x0000).
- Status information: 0x0000000E (Smart extension service Enable status)
- Status information: 0x0000000D (Smart extension service Disable status)

(3) Example of smart extension status read message

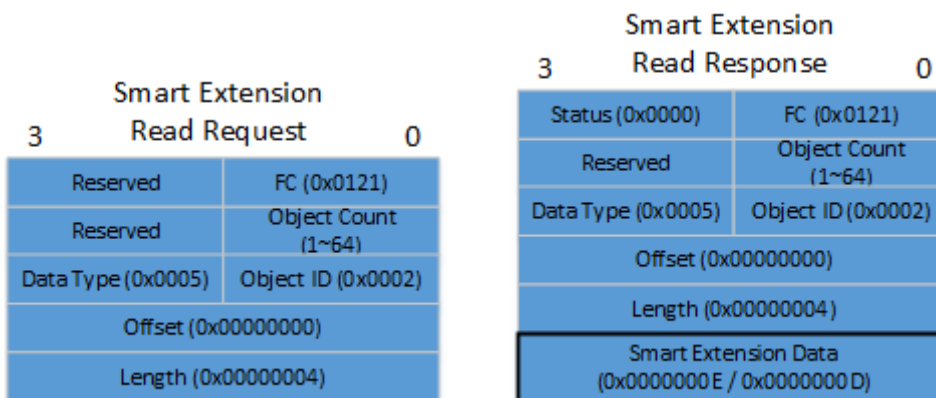

8.4.3 P2P object

The structure of the P2P object (Object ID :3) is as follows.

P2P object (Object ID: 3)

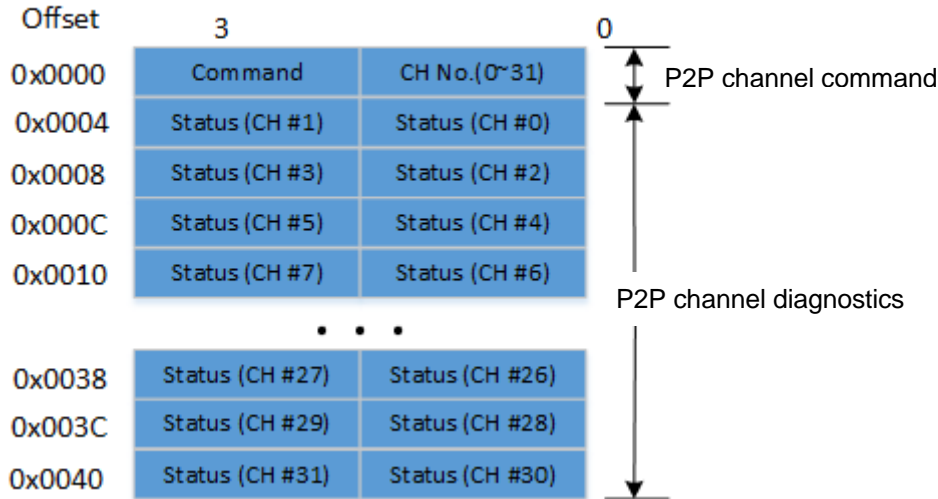

(1) P2P client channel commands using CP\_MSG (Write Only)

- Write control command to P2P object offset (0x0000).
- Channel No: TCP channel index number set as client of P2P channel parameter ( 0 ~ 31)
- Command: Refer to the following table for supported command items.

(An error ( UNIV\_ERR\_INVALID\_PRM ) response to an input value outside the set range of each field of the command.)

Code (hex)	Name	Description
0x0001	CONNECT_REQ	Start connection to the server of the P2P channel set as a TCP client (only channels with a channel status of Disconnected are available; otherwise, an error is returned)
0x0002	RESET_REQ	After sending TCP RESET to P2P channel set as TCP client, internal forced connection is released. (Only possible if the channel is in CONNECTED state, otherwise an error is returned.)

(2) Status read command of P2P client channel using CP\_MSG (Read Only)

- Reads the value of P2P channel diagnosis area (offset: 0x0004 ~ 0x0040) by “reading” operation. The minimum read unit is 4 bytes.
- Refer to the following table for current status information of channels.

Code (hex)	Name	Description
0x0000	DISCONNECTED	Connection release (IDLE)
0x0001	CONNECTED	Connection complete
0x0002	WAIT_CONNECTING	The server is waiting for a connection from the client.
0x0003	CONNECTING	Connecting
0x0004	DISCONNECTING	Disconnecting

(3) P2P object error code

Code (hex)	Name	Description
0x0130	UNIV_P2P_ERR_BAD_CHANNEL	P2P channel parameters do not meet the conditions.
0x0131	UNIV_P2P_ERR_IDLE_CHANNEL	P2P channel is in IDLE state.
0x0132	UNIV_P2P_ERR_BUSY_CHANNEL	P2P channel is in BUSY state.

(4) Example of P2P object read request/response message structure

- P2P Read Request message

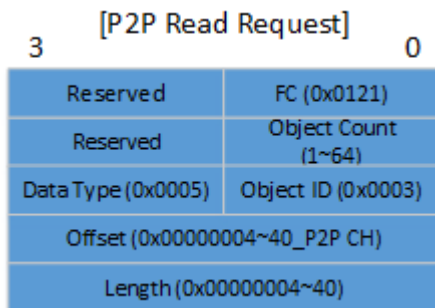

- P2P Read Response message structure

[P2P Read Response]

3	0
Status (0x0000)	FC (0x0121)
Reserved	Object Count (1~64)
Data Type (0x0005)	Object ID (0x0003)
Offset (0x00000004~40)	
Length (0x00000004~40)	
Status (CH #1)	Status (CH #0)
Status (CH #3)	Status (CH #2)
...	
Status (CH #29)	Status (CH #28)
Status (CH #31)	Status (CH #30)

8.4.4 Diagnosis object

The structure of the Diagnosis object (Object ID :4) is as follows.

Diagnostics object (Object ID: 4)

Offset	3	0
0x0000	Module Information (RD)	
0x0100	Module Feature (RD)	
0x0200	Server Statistics Information (RD)	
0x0400	Detail Media Statistics Information (RD, WR)	
0x0500	RAPIEnet Alive Node List (RD)	
0x0800	RAPIEnet Autoscan Type 1 (RD)	
0x1000	RAPIEnet Autoscan Type 2 (RD)	
0x1800	RAPIEnet Autoscan Type 3 (RD)	
0x2000	Smart Exp.Service Statistics Information (RD)	
0x3000	Frame Capture Control (WR) -Start, Stop, Erase	
0x3004	Frame Capture Filter(RD, WR)	

(1) Module Information read using CP MSG

3			0
StationNo	Link Sub Type	Link Type	Parameter Exist
IP Address			
OS Date			
MAC Address			
Link Status2	Link Status1	MAC Address	
HW Status		HW Version	
Reserved		OS Version	
Media Status[1]	Media Status[0]	Reserved	Run Mode

Member name	Value
Parameter Exist	0X00: No Basic parameter 0X00: normal operation in Basic parameter
Link Type	0x01 : FENet
Link Sub Type	0x01: copper x 2port(XGL-EFMTB) 0x02 : Fiber Optic x 2port(XGL-EFMFB) 0x04 : Copper 1port + Fiber Optic 1port(XGL-EFMHB)
Station No.	Station Number
IP Address	IP Address
Os Date	QS Date
MAC Address	MAC Address
Port 1 Link Status	0 : Link Down 1 : Link Up
Port 2 Link Status	0 : Link Down 1 : Link Up
HW Version	Hardware Version
HW Status	Hardware Status
OS Version	OS Version
Reserved	-
RUN Mode	b'0 : P2P Service Enabled b'1 : HS Service Enabled b'2 : Remote Loader is in service b'3 : Server is working Note : See Server mode in basic parameter fo detail
Reserved	-
Media Status Port1	0 : Auto (Link down) 1 : 10M Half 2 : Reserved 3 : 100Mbps Half 4 : 100Mbps Full
Media Status Port2	5 : 100Mbps FX Half 6 : 100Mbps FX Full 7 : 1000Mbps Full 8 : 1000Mbps X Full

- Ladder program writing example(XGK)

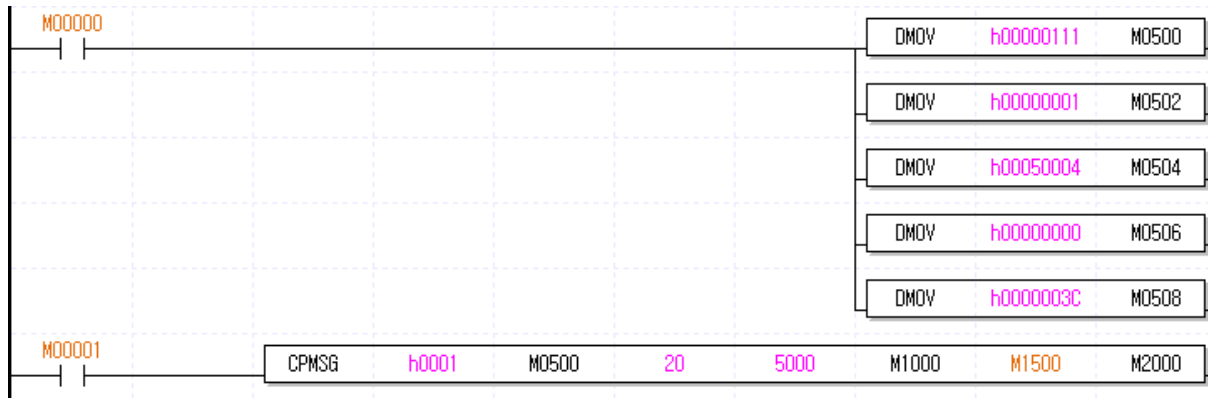

	0	1	2	3	4	5	6	7	8	9
M1000	0121	0000	0001	0000	0004	0005	0000	0000	003C	0000
M1010	0101	0001	A8C0	0201	0217	2022	E000	0591	9769	0101
M1020	0200	0000	623C	0000	0008	0404	0000	0000	0000	0000

(2) Read Feature List of FEnet module

- It responds with a list of features supported by FEnet. The meaning of the Feature List is assigned to each bit, and if the bit is 1, it is supported, if it is 0, it is not supported.

Feature name	Bit Position	Feature description
BPSC LARGE RAM SUPPORT	b'0	Supports large-capacity backplane common RAM
RAPIENET PLUS SUPPORT	b'1	Mountable on RAPIEnet+ slave
LD MULTI CONNECT SUPPORT	b'2	Loader service multi-connection support
DIAG MULTI ACC SUPPORT	b'3	Diagnostic service multi-message support
MSG TUNNELING SUPPORT	b'4	n-Backplane Message Tunneling Support
LARGE SERVER MSG SUPPORT	b'5	Large server message support
Reserved	b'6 ~ b'31	-
Reserved	b'32	Support for smart extension high-speed output mode
PASS THRU SUPPORT	b'33	Message Pass through support

- Ladder program writing example(XGK)

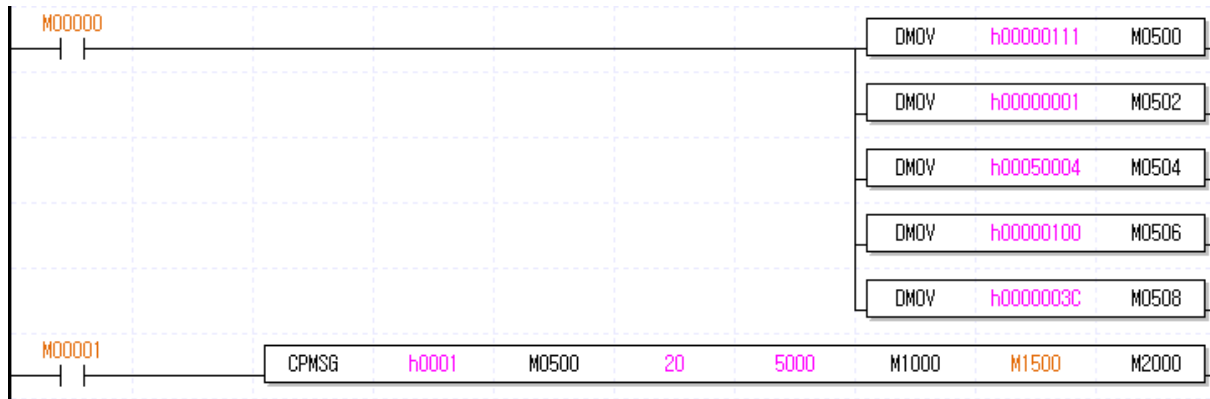

Hexadecimal

	0	1	2	3	4	5	6	7	8	9
M1000	0121	0000	0001	0000	0004	0005	0100	0000	003C	0000
M1010	003F	0000	0001	0000	0000	0000	0000	0000	0000	0000

Binary number

	0	1	2	3	4	5	6	7	8	9
M1000	0000 0001 0010 0001	0000 0000 0000 0000	0000 0000 0000 0001	0000 0000 0000 0000	0000 0000 0000 0100	0000 0000 0000 0101	0000 0001 0000 0000	0000 0000 0000 0000	0000 0000 0011 1100	0000 0000 0000 0000
M1010	0000 0000 0011 1111	0000 0000 0000 0000	0000 0000 0000 0001	0000 0000 0000 0000	0000 0000 0000 0000	0000 0000 0000 0000	0000 0000 0000 0000	0000 0000 0000 0000	0000 0000 0000 0000	0000 0000 0000 0000

(3) Frame capture control

- To start frame capture, write 0x0000000E to Frame Capture Control offset (0x3000) using the CP MSG Write function.
- To start frame capture, write 0x0000000D to Frame Capture Control offset (0x3000) using the CP MSG Write function.
- To erase captured frame data, write 0x0000000C to Frame Capture Control offset (0x3000) using CP MSG Write function.
- If no frame capture filter is set, all frames are recorded.
- Up to 2280 frames can be saved, and when the frame recording space is full, new frames are recorded after deleting the old frame recording. (Over write)

3
0

Frame Capture Control  
 Enable: 0x0000000E  
 Disable: 0x0000000D  
 Clear: 0x0000000C

- Ladder program writing example(XGK)
  - Enable

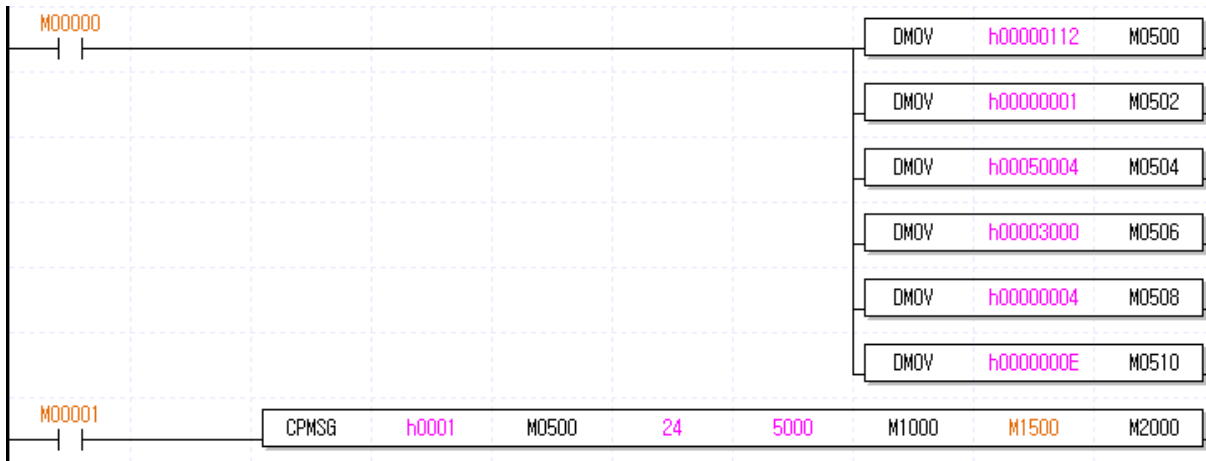

	0	1	2	3	4	5	6	7	8	9
M1000	0122	0000	0000	0000	0000	0000	0000	0000	0000	0000

Module Log

Event History   Communication Log   **Error Frame Log**

Standard Information

Base No.:

Slot No.:

Select View

View by HEX

View by ASCII

No	Date	Time	Description
13	2022-11-16	08:37:40.6...	00 E0 91 02 05
14	2022-11-16	08:37:41.6...	00 E0 91 02 05
15	2022-11-16	08:37:42.6...	00 E0 91 02 05
16	2022-11-16	08:37:43.6...	00 E0 91 02 05
17	2022-11-16	08:37:58.6...	00 E0 91 02 05
18	2022-11-16	08:37:59.6...	00 E0 91 02 05
19	2022-11-16	08:38:00.6...	00 E0 91 02 05
20	2022-11-16	08:38:01.6...	00 E0 91 02 05
21	2022-11-16	08:38:02.5...	FF FF FF FF FF FF
22	2022-11-16	08:38:02.6...	00 E0 91 02 05
23	2022-11-16	08:38:03.6...	00 E0 91 02 05
24	2022-11-16	08:38:04.6...	00 E0 91 02 05
25	2022-11-16	08:38:05.6...	00 E0 91 02 05
26	2022-11-16	08:38:06.6...	00 E0 91 02 05

- Disable

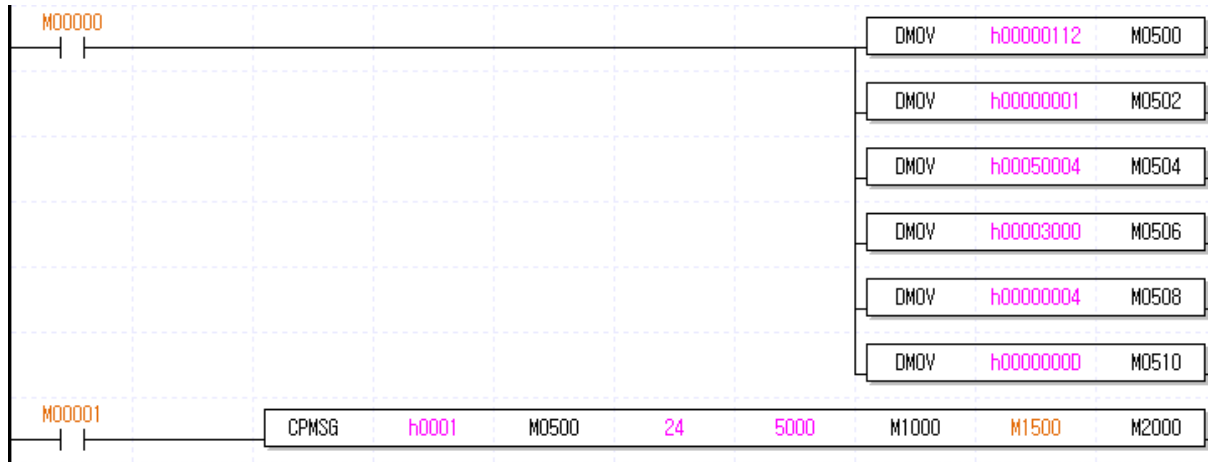

	0	1	2	3	4	5	6	7	8	9
M1000	0122	0000	0000	0000	0000	0000	0000	0000	0000	0000

**Module Log**

Event History   Communication Log   **Error Frame Log**

Standard Information

Base No.:

Slot No.:

Select View

View by HEX

View by ASCII

No	Date	Time	Description
59	2022-11-16	08:41:43.6...	00 E0 91 02 05
60	2022-11-16	08:41:44.6...	00 E0 91 02 05
61	2022-11-16	08:41:45.6...	00 E0 91 02 05
62	2022-11-16	08:41:46.6...	00 E0 91 02 05
63	2022-11-16	08:41:47.5...	FF FF FF FF FF FI
64	2022-11-16	08:41:47.6...	00 E0 91 02 05
65	2022-11-16	08:41:48.6...	00 E0 91 02 05
66	2022-11-16	08:41:49.6...	00 E0 91 02 05
67	2022-11-16	08:41:50.6...	00 E0 91 02 05
68	2022-11-16	08:41:51.6...	00 E0 91 02 05
69	2022-11-16	08:41:52.5...	FF FF FF FF FF FI
70	2022-11-16	08:41:52.6...	00 E0 91 02 05
71	2022-11-16	08:41:53.6...	00 E0 91 02 05
72	2022-11-16	08:41:54.6...	00 E0 91 02 05

- Clear

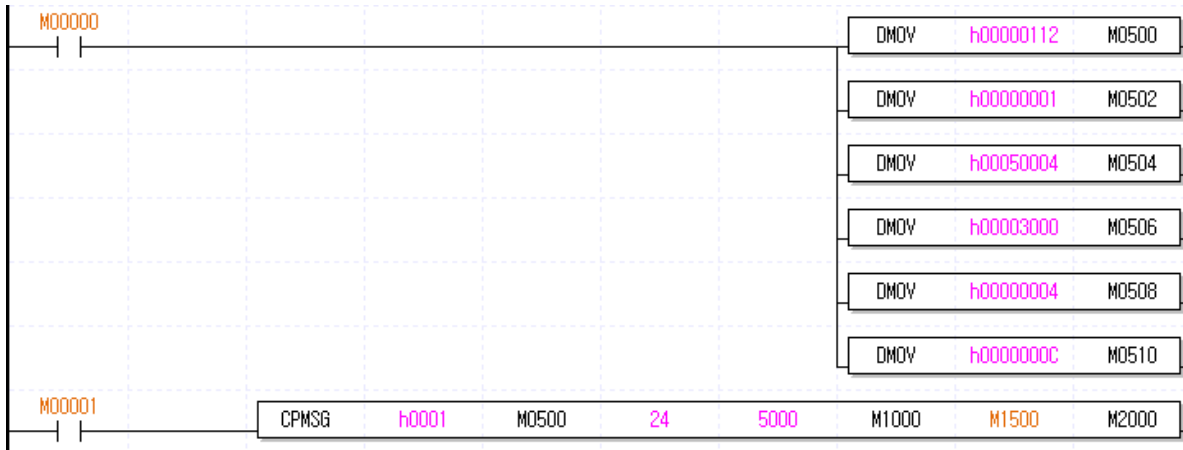

	0	1	2	3	4	5	6	7	8	9
M1000	0122	0000	0000	0000	0000	0000	0000	0000	0000	0000

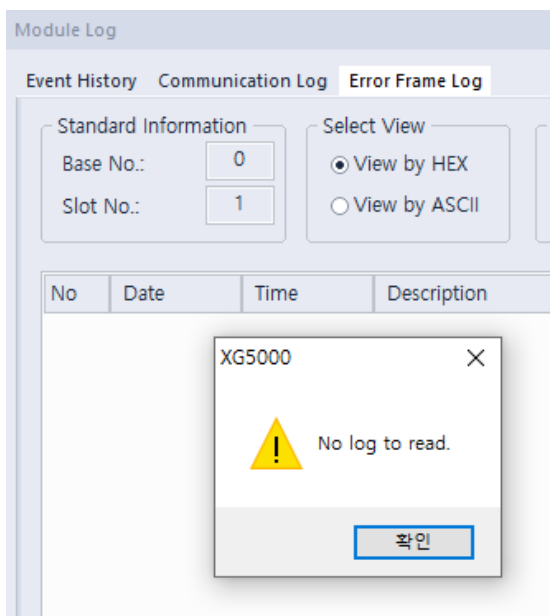

(4) Frame Capture Filter Settings

- Frame capture filters can be set from 1 to 4. All frames are recorded if no frame capture filter is set. If you want to record by selecting a frame, set the frame filter.

3	0
Logic	Combination(fix, 0x0001)
Offset	Field
Reserved	Length
Filter Data	
Filter Data	
Logic	Combination
Offset	Field
Reserved	Length
Filter Data	
Filter Data	
Logic	Combination
Offset	Field
Reserved	Length
Filter Data	
Filter Data	
Logic	Combination
Offset	Field
Reserved	Length
Filter Data	
Filter Data	

- For each filter, refer to the description in the table below.

Member name	Value
combination	Use 0x0001 for the first frame capture filter item OR(0x0002): It decides whether to receive or not by OR condition with the result of the previous frame capture filter item AND(0x0003): It decides whether to receive or not by OR condition with the result of the previous frame capture filter item
Logic	Set the conditions of the set capture filter. - EQUAL (0x0000): Record the frame when the field area of the inspected frame is the same. - NOT EQUAL (0x0001): Record the frame when the field area of the inspected frame is not the same.
field	Specifies the field in the frame to condition on. 0X0000: As a user-specified area, the offset, length, and filter data of the frame to be compared must be specified. 0X0001: As a DST_MAC filter, it compares the destination MAC address range in the frame to be compared. Enter the destination MAC address 6Byte in the filter data area. 0X0002: As a SRC_MAC filter, it compares the source MAC address range in the frame to be compared. Enter the compared source MAC address 6Byte in the filter data area. 0X0003: As an Ether Type filter, it compares the Ethernet Type field in the frame to compare. Enter Ether Type 2Byte to be compared in the filter data area. 0X0004: It is used to record the entire frame that is TCP. There is no need to set offset, length and filter data. 0X0005: It is used to record the entire frame that is UDP. There is no need to set offset, length and filter data. 0X0006: As an SRC_IP filter, if it is an IP protocol frame, the source IP field is compared. Enter the compared source IP address 4Byte in the filter data area. 0X0007: As an DSP_IP filter, if it is an IP protocol frame, the source IP field is compared. Enter the destination IP address 4Byte in the filter data area. 0X0008: As an SRC_IP filter, if it is an IP protocol frame, the send Port field is compared. Enter port number 2Byte in the filter data area. 0X0009: As an DST_PORT filter, if it is an IP protocol frame, the destination Port field is compared. Enter port number 2Byte in the filter data area.

Offset	Only used when the Custom Area Frame filter is selected. Enter the offset area where the data to be compared is located. (Input range: 0 to 127)
Length	Only used when the Custom Area Frame filter is selected. Enter the length of data to compare. Up to 8 bytes
Reserved	-
Filter data	The value to be input differs depending on the Field setting. (Refer to Field Description.) Ex) When entering the IP "192.168.1.10" value, enter 0x0A01A8C0 Ex) When entering the IP "2.3.4.5" value, enter 0x05040302 Ex) When entering the Ether Type 0x0800 value, enter 0x00000800 Ex) When entering Port 2000 (0x07D), input 0x07D0 Ex) When entering Ethernet MAC address 00:E0:91:05:67:98, input 0x0591E000, 0x00009867 Ex) If user-defined filter is used, same as Ethernet MAC address.

### 8.4.5 Ethernet option object

The structure of the Ethernet option object (Object ID :8) is as follows.

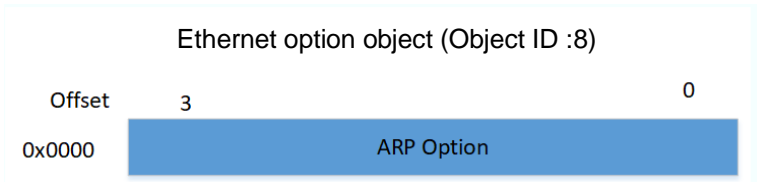

#### (1) ARP Permanent option Enable command using CP\_MSG

- ARP Permanent Enable: 0x00000004

- If the ARP Permanent option is enabled, the MAC address stored in the cache will be continuously used without re-updating if there is a relative MAC address in the ARP cache.

If the ARP permanent option is not enabled, the ARP cache will be updated every 400 seconds.



## Chapter 9 Troubleshooting

An explanation of how to check the causes of a failure or an error that may occur during system operation and measures. The following procedure can be used to check the status of the Ethernet module. Please follow the troubleshooting procedures to determine the abnormal module status.

(1) Error checking method by LED on the front of module

Check whether there is a problem with the Ethernet module by lighting the LED on the front of the Ethernet module.

(2) Error checking method by XG5000 connection(Only Ethernet module)

1) Error / Warning check during PLC operation

2) Error / Warning check during communication module operation.

- Error / Warning check during communication module operation(P2P/dedicated service)
- Error / Warning check during communication module operation(Smart Extension Service)
- Diagnostic variables during communication module operation(Smart Extension Service)

3) View Communication Module Log

(3) XGT dedicated communication error code(Only Ethernet module)

## 9.1 LED Error Check

To check the fault or status of the module, check the status of the communication module according to the lighting status of the LED.

### 9.1.1 Abnormal operation indication of XGL-EFMT / EFMF

LEDs on the front of the Ethernet module provide easy operation.

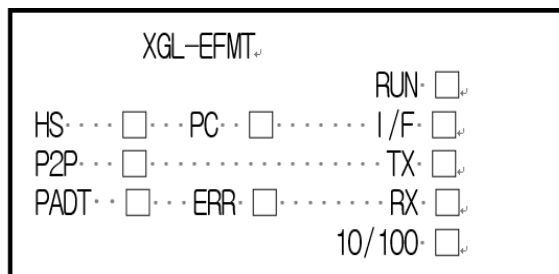

LED Name	Error contents	Solution
RUN	LED off after PLC power on	1) Mounting error of Ethernet communication module - Check if the DC 5V power supply of the power supply module is abnormal.. - Check if the communication module is installed in the base normally. 2) Use XG5000 to check if communication module is recognized properly.
I/F	LED on or off during normal communication	1) Check if the CPU works normally 2) Check if the communication module is installed in the base normally. 3) Check that the information is correctly recognized by the xG5000.
P2P	Turned off during P2P service	1) Check if standard settings parameters of FEnet module are normally configured by using XG5000. 2) Check if the function block / command is normal. 3) Check if the communication connection is normal. 4) Check if P2P link enable (allowed) of XG5000 menu is set.
HS	Turned off during high speed link service	1) Check if standard settings parameters of FEnet module are normally configured by using XG5000. 2) Check if HS link setting is normal. 3) Check if high speed link link enable (allowed) of XG5000 menu is set.
PADT	Turned off during remote access service	1) Check if the IP address for remote connection is correct. 2) Check if remote connection is released with XG5000.
PC	Turned off during dedicated service	1) Check if the IP address for dedicated connection is correct. 2) Check if host table setting of standard settings is enabled and if it is enabled, check if IP of MMI (PC) is registered in dedicated connection table. 3) Check if connection request is made in MMI (PC) device.
ERR	Turned on after power on	1) Check if standard settings parameters of FEnet module are normally configured by using XG5000. 2) Check if there is any interface error with the CPU.

9.1.2 Abnormal operation indication of XGL-EFMTB / EFMF

Checked by the LED on the front of the Ethernet module.

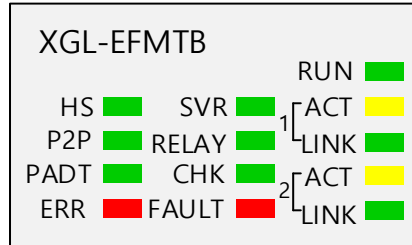

LED Name	Error contents	Solution
RUN	LED off after PLC power on	1) Mounting error of Ethernet communication module - Check if the DC 5V power supply of the power supply module is abnormal.. - Check if the communication module is installed in the base normally. 2) Use XG5000 to check if communication module is recognized properly.
	Flicker after PLC power on	1) Normal operation is impossible due to error after power on - The power was turned ON, but a module error occurred. (V6.0 or higher)
HS	Turned off during high speed link service	1) Check if standard settings parameters of FENet module are normally configured by using XG5000. 2) Check if HS link setting is normal. 3) Check if high speed link link enable (allowed) of XG5000 menu is set.
	Flicker during high speed link service	1) Check if parameter is normal due to HS link parameter error. (V6.0 or higher)
P2P	Turned off during P2P service	1) Check if standard settings parameters of FENet module are normally configured by using XG5000. 2) Check if the function block / command is normal. 3) Check if the communication connection is normal. 4) Check if P2P link enable (allowed) of XG5000 menu is set.
	Flicker during P2P service	1) Check whether the parameter is normal with P2P parameter error.. (V6.0 or higher)
PADT	Turned off during remote access service	1) Check if the IP address for remote connection is correct. 2) Check if remote connection is released with XG5000.
ERR	Turned on after power on	This is the LED which is turned on in the event of a critical error of the module. If the phenomenon repeats after turning on the power again, request A / S.
SVR	Turned off during dedicated service	1) Check if the IP address for dedicated connection is correct. 2) Check if host table setting of standard settings is enabled and if it is enabled, check if IP of HMI (PC) is registered in dedicated connection table. 3) Check if connection request is made in HMI (PC) device.
RELAY	Communication speed mismatch between relay ports	If the Relay option of the standard settings parameter is checked, if the speed of each Ethernet port of Port 1 and Port 2 is the same, it is ON when the frame can be relayed. Even if the Relay option is checked, it blinks (V6.0 or higher) if the media speed is different between the two ports. OFF if the Relay option is not checked. * Since 10Mbps does not support relay function, Relay LED is turned off when Relay option is checked at 10Mbps.

LED Name	Error contents	Solution
CHK	Turned on after power on	<ol style="list-style-type: none"> <li>1) Check if the IP redundancy setting is on the same network. (V5.0 or higher)</li> <li>2) Check if the media of the standard settings parameter and the product have the same media type.</li> <li>3) Check the RAPIEnet slave parameters for errors. (V6.0 or higher)</li> <li>4) Check the RAPIEnet slave parameters for errors. (V6.0 or higher)</li> <li>5) A packet receiving overload has occurred. Check communication line and communication data</li> </ol>
	Flicker during communication	<ol style="list-style-type: none"> <li>1) Check if RAPIEnet network connection status is changed from Ring to Line.(V6.0 or higher)</li> <li>2) Check if the module which has disabled EB or module swap (hot swap) option has been detached while the smart extension service is in operation. (V8.0 or higher)</li> </ol>
FAULT	Flicker during communication	<ol style="list-style-type: none"> <li>1) Check the communication cable and Ethernet connection.</li> <li>2) Check the network status and the communication module history.</li> <li>3) Check the error status of the EB with the 'EB or module exchange (hot swap) in operation' option enabled during the smart expansion service EB. The error status of EB can be checked conveniently using diagnostic variables. For details on the operation of diagnostic variables according to the 'EB or module exchange (hot swap) option during operation', refer to '4.3.3 Diagnosis variable operation according to the EB or module exchange (hot swap) option during operation'.</li> </ol>
	ON	<ol style="list-style-type: none"> <li>1) Check if the station number of RAPIEnet self station no. And other RAPIEnet device is overlapped.(V6.0 or higher)</li> <li>2) Check if the IP redundancy setting is on the same network. (V6.0 or higher)</li> <li>3) Check the error status of the EB with the 'EB or module exchange (hot swap) in operation' option Disable during the smart expansion service EB. The error status of EB can be checked conveniently using diagnostic variables. For details on the operation of diagnostic variables according to the 'EB or module exchange (hot swap) option during operation', refer to '4.3.3 Diagnosis variable operation according to the EB or module exchange (hot swap) option during operation'.</li> </ol>
ACT	Turned off during communication	Turns off when there is no frame send or receive.
LNK	Turned off during communication	Check the communication cable connection status (host station / destination side).

9.1.3 Abnormal operation display of XGL-EH5T

Check the normal operation through the LED on the front of the switch module.

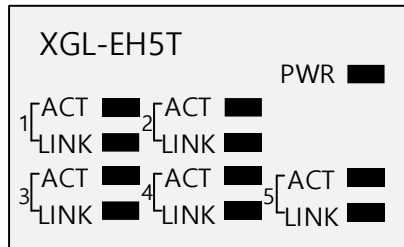

The switch module only needs to be powered from the base and no parameter setting is required.

If all LEDs except the power LED of the switch module blink once after the power is applied, the switch module is normal.

LED contents	Error contents	Solution
PWR	LED off after PLC power on	1) Mounting error of Switch module - Check if the DC 5V power supply of the power supply module is abnormal.. - Check if the communication module is installed in the base normally.
ACT	LED Off	1) Check if the cable is properly connected to the port. LED is not On when not connected 2) Make sure the data is sent and received normally
LNK	LED Off	1) Check if the cable is properly connected to the port. LED is not On when not connected

## 9.1.4 Abnormal operation display of XOL-ES4T/ES4H

Check the normal operation through the LED on the front of the switch module.

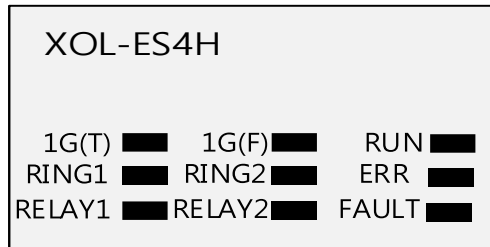

The switch module only needs to be powered from the base and no parameter setting is required.

LED contents	Error contents	Solution
RUN	LED off after PLC power on	1) Mounting error of Switch module - Check if the DC 24V power supply of the power supply module is abnormal..
ERR	LED Off	1) Check if the cable is properly connected to the port. LED is not On when not connected 2) Make sure the data is sent and received normally
FAULT	LED Off	1) Reconfirm the station number due to collision with MRS station number of the same network.
1G	LED Off	1) Channel 1 and 2 are connected by 100M. 2) Channel 3 and 4 are connected by 100M.
RING	LED off/flicker	1) Channel 1 and 2 are connected in a line topology. 2) Channel 3 and 4 are connected in a line topology.
RELAY	LED Off	1) This is the case when channels 1 and 2 do not operate as a relay. 2) This is the case when channels 3 and 4 do not operate as a relay.

## 9.2 Error checking method by XG5000 connection

### 9.2.1 Error / Warning check during PLC operation

By XG5000 program, you can monitor the communication module abnormally. After connecting to CPU port, check through [Online]->[Diagnostics ->] [PLC History] and [PLC Error / Warning] of XG5000.

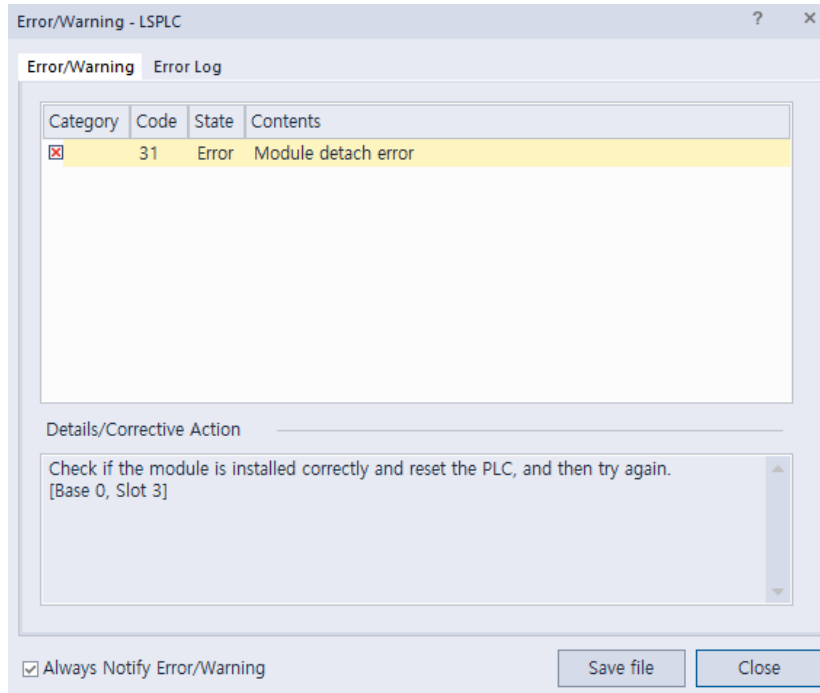

If the module has hardware error or CPU interface error, the LED of the communication module itself is abnormal. Also programs also provide a quick way to see status information. The above figure is error / warning information that can be checked through [PLC History] of [Online] menu of XG5000.

## (1) Error / Warning check during XGK CPU module operation

Code	Cause of error	Action (Restart Mode After Action)	Operation Status	LED status	Diagnostics point
2	Data Bus Error	If the same error repeats when power is turned on again, A/S is requested.	Error	Blink in full LED order	Power on
3	Data RAM Error	If the same error repeats when power is turned on again, A/S is requested.	Error	Blink in full LED order	Power on
4	Clock IC (RTC) Error	If the same error repeats when power is turned on again, A/S is requested.	Error	ERR : ON	Power on
6	Program memory error	If the same error repeats when power is turned on again, A/S is requested.	Error	ERR : ON	Power on
10	USB IC error	If the same error repeats when power is turned on again, A/S is requested.	Error	ERR : ON	Power on
11	backup RAM Error	If the same error repeats when power is turned on again, A/S is requested.	Error	ERR : ON	Power on
12	backup Flash Error	If the same error repeats when power is turned on again, A/S is requested.	Error	ERR : ON	Power on
13	Base information error	If the same error repeats when power is turned on again, A/S is requested.	STOP	ERR : ON	Power on RUN mode change
22	Backup flash memory program error	Restart after modifying program of backup Flash	Error	ERR : ON	RUN mode change after reset
23	Program execution error	Start after reloading the program Replace the battery if there is something wrong with the battery After reloading the program and checking the storage status, if there is an error, replace the CPU module.	STOP	ERR : ON	RUN mode change after reset
24	I/O parameter error	Start after reloading I/O parameter Battery change if battery has a problem. Check the preservation status after I/O parameter reloading and if error occurs, change the CPU module.	STOP	ERR : ON	RUN mode change after reset
25	Basic parameter error	Start after reloading basic parameters Replace the battery if there is something wrong with the battery After reloading basic parameters and checking the storage status, if there is an error, replace the CPU module.	STOP	ERR : ON	RUN mode change after reset
26	Exceed execution range error	Restart after downloading program If it occurs repeatedly, request service center.	STOP	ERR : ON	RUN mode change after reset
27	Compile error	Start after reloading program. If it occurs repeatedly, request service center.	STOP	ERR : ON	RUN mode change after reset
30	Module set in parameter and the installed module does not match.	After checking the wrong position of slot by XG5000, modify the module or parameter and then restart. Reference flag: module type mismatch error flag	STOP (RUN)	ERR : ON (P.S. : ON)	RUN mode change

31	Module falling during operation or additional setup	After checking the position of falling/adding slot by XG5000, modify the installation status of module and then restart (according to parameter). Reference flag: Module detach error flag	STOP (RUN)	ERR : ON (P.S. : ON)	Scan end
32	Fuse cutoff of fuse built-in module during operation	After checking the position of slot where the fuse cutoff occurs by XG5000, change the fuse and then restart (according to parameter). Reference flag: Fuse break error flag	STOP (RUN)	ERR : ON (P.S. : ON)	Scan end

Code	Cause of error	Action (Restart Mode After Action)	Run status	LED status	Diagnostics point
33	Data of I/O module does not access normally during operation.	After checking the position of slot where the access error occurs by XG5000, change the module and restart (according to the parameter). Reference flag: I / O module read / write error flag	STOP (RUN)	ERR : ON (P.S. : ON)	Scan end
34	Normal access of special/link module data during operation not available.	Check the location of the slot where access error occurred with XG5000, replace the module and restart (according to the parameter). Reference flag: Special / Communication Module Interface Error	STOP (RUN)	ERR : ON (P.S. : ON)	Scan end
39	Abnormal stop of CPU or malfunction	Abnormal system shutdown due to noise or hardware failure 1) If it occurs repeatedly when power reinput, request service center 2) Noise measures	STOP	RUN: ON ERR : ON	Always
40	Scan time of program during operation exceeds the scan watchdog time designated by parameter.	After checking the scan watchdog time designated by parameter, modify the parameter or the program and then restart.	STOP	RUN: ON ERR : ON	In operation
41	Operation error occurs while running the user program.	Remove calculation error-> Redownload Program and Restart	STOP	RUN: ON ERR : ON	In operation
42	The stack exceeds the normal range while running the program	Restart	STOP	RUN: ON ERR : ON	In operation
43	Base double setting error	Reset after confirming the base setting switch	STOP	ERR : ON	RUN mode change after reset
44	Timer index user error	Start after modifying / re-downloading the timer index program	STOP (RUN)	RUN: ON ERR : ON	Scan end
50	Detecting critical error of external device by user program during operation	Repair and restart the wrong device by referring to the fault detection flag of the external device (according to the parameter).	STOP (RUN)	ERR : ON (P.S. : ON)	Scan end
55	The number of tasks waiting to run exceeds the specified range	If it occurs repeatedly after restarting, check the installation environment if error continues, request service center	STOP (RUN)	ERR : ON (P.S. : ON)	In operation
60	E_STOP function executed	Remove the error factor that triggered the E_STOP function in the program and turn the power on again	STOP	RUN: ON ERR : ON	In operation
61	Operation error	When STOP: Correct the program by checking the operation error details with XG5000.. When RUN: Refer to error step of F area	STOP (RUN)	ERR : ON (P.S. : ON)	In operation

500	Data memory backup not possible	If the battery is OK, turn the power back on. Switch to STOP mode in remote mode	STOP	ERR : ON	Reset
501	Clock data abnormal	If there is no problem with the battery, resetting the time with a device such as XG5000.	-	CHK: ON	Always
502	Low battery voltage	Battery change in the state of power input.	-	BAT: ON	Always

## (2) Error / Warning check during XGI CPU module operation

Code	Cause of error	Action (Restart Mode After Action)	Operation Status	LED status	Diagnostics point
2	Data Bus Error	If the same error repeats when power is turned on again, A/S is requested.	Error	Blink in full LED order	Power on
3	Data RAM Error	If the same error repeats when power is turned on again, A/S is requested.	Error	Blink in full LED order	Power on
4	Clock IC (RTC) Error	If the same error repeats when power is turned on again, A/S is requested.	Error	ERR : ON	Power on
6	Program memory error	If the same error repeats when power is turned on again, A/S is requested.	Error	ERR : ON	Power on
10	USB IC error	If the same error repeats when power is turned on again, A/S is requested.	Error	ERR : ON	Power on
11	backup RAM Error	If the same error repeats when power is turned on again, A/S is requested.	Error	ERR : ON	Power on
12	backup Flash Error	If the same error repeats when power is turned on again, A/S is requested.	Error	ERR : ON	Power on
13	Base information error	If the same error repeats when power is turned on again, A/S is requested.	STOP	ERR : ON	Power on RUN mode change
22	Backup flash memory program error	Restart after modifying program of backup Flash	Error	ERR : ON	RUN mode change after reset
23	Program execution error	Start after reloading the program Replace the battery if there is something wrong with the battery After reloading the program and checking the storage status, if there is an error, replace the CPU module.	STOP	ERR : ON	RUN mode change after reset
24	I/O parameter error	Start after reloading I/O parameter Battery change if battery has a problem. Check the preservation status after I/O parameter reloading and if error occurs, change the CPU module.	STOP	ERR : ON	RUN mode change after reset
25	Basic parameter error	Start after reloading basic parameters Replace the battery if there is something wrong with the battery After reloading basic parameters and checking the storage status, if there is an error, replace the CPU module.	STOP	ERR : ON	RUN mode change after reset
30	Module set in parameter and the installed module does not match.	After checking the wrong position of slot by XG5000, modify the module or parameter and then restart. Reference flag: module type mismatch error flag	STOP (RUN)	ERR : ON (P.S. : ON)	RUN mode change
31	Module falling during operation or additional setup	After checking the position of falling/adding slot by XG5000, modify the installation status of module and then restart (according to parameter). Reference flag: Module detach error flag	STOP (RUN)	ERR : ON (P.S. : ON)	Scan end

32	Fuse cutoff of fuse built-in module during operation	After checking the position of slot where the fuse cutoff occurs by XG5000, change the fuse and then restart (according to parameter). Reference flag: Fuse break error flag	STOP (RUN)	ERR : ON (P.S. : ON)	Scan end
----	--	---	---------------	-------------------------	----------

Code	Cause of error	Action (Restart Mode After Action)	Run status	LED status	Diagnostics point
33	Data of I/O module does not access normally during operation.	After checking the position of slot where the access error occurs by XG5000, change the module and restart (according to the parameter). Reference flag: I / O module read / write error flag	STOP (RUN)	ERR : ON (P.S. : ON)	Scan end
34	Normal access of special/link module data during operation not available.	Check the location of the slot where access error occurred with XG5000, replace the module and restart (according to the parameter). Reference flag: Special / Communication Module Interface Error	STOP (RUN)	ERR : ON (P.S. : ON)	Scan end
39	Abnormal stop of CPU or malfunction	Abnormal system shutdown due to noise or hardware failure 1) If it occurs repeatedly when power reinput, request service center 2) Noise measures	STOP	RUN: ON ERR : ON	Always
40	Scan time of program during operation exceeds the scan watchdog time designated by parameter.	Check the the scan watchdog time time specified by the parameter and Restart after modifying the parameter or program.	STOP	RUN: ON ERR : ON	In operation
41	Operation error occurs while running the user program.	Remove calculation error-> Redownload Program and Restart	STOP (RUN)	RUN: ON ERR : ON	In operation
42	The stack exceeds the normal range while running the program	Restart	STOP	RUN: ON ERR : ON	In operation
44	Timer index user error	Start after modifying / re-downloading the timer index program	STOP (RUN)	RUN: ON ERR : ON	Scan end
50	Detecting critical error of external device by user program during operation	Repair and restart the wrong device by referring to the fault detection flag of the external device (according to the parameter).	STOP (RUN)	ERR : ON (P.S. : ON)	Scan end
60	E_STOP function executed	Remove the error factor that triggered the E_STOP function in the program and turn the power on again	STOP	RUN: ON ERR : ON	In operation
500	Data memory backup not possible	If the battery is OK, turn the power back on. Switch to STOP mode in remote mode	STOP	ERR : ON	Reset
501	Clock data abnormal	If there is no problem with the battery, resetting the time with a device such as XG5000.	-	CHK: ON	Always
502	Low battery voltage	Battery change in the state of power input.	-	BAT: ON	Always

Notes

- 1) 1) Check the error No. 2 ~ 13 in the “Error code during CPU operation” at the AS center.
- 2) Error number 22 or less can be confirmed using the error history of XG5000.

## (3) Error / Warning check during XGR CPU module operation

Code	Cause of error	Action (Restart Mode After Action)	Run status	LED status	Diagnostics point
13	Base information error	A / S request if repeated on power up	STOP	S013	Power on RUN mode change
23	Program execution error	Start after reloading the program(Cold) Replace the battery if there is something wrong with the battery(Cold) After reloading I / O parameters and checking the storage status, if there is an error, replace the CPU module(Cold)	STOP	E023	RUN mode change after reset
24	I/O parameter error	Check the I / O parameters and the installed module to set and download the same I / O parameters as the mounted module	STOP	E024	RUN mode change after reset
25	Basic parameter error	Start after reloading the basic parameter(Cold) (Enable to download in STOP mode)	STOP	E025	RUN mode change after reset
28	Redundancy parameter error	Start after reloading the redundancy parameter (Do not check when downloading during run)	STOP	E028	Power on, program loading
29	Special parameter error	Start after reloading the special parameter (Do not check when downloading during run)	STOP	E029	Power on, program loading
30	Module set in parameter and the installed module does not match.	Check the location of wrong slot with XG5000 and restart after modifying the module or parameter.(Cold when modifying a program) Reference flag: Module type mismatch error flag(_IO_TYER, _IO_TYER_N, _IO_TYERR[n])	STOP (RUN)	E030	Power on, Program loading Change RUN mode
31	Module falling during operation or additional setup	Restart the module after checking the position of detach / additional slot with XG5000 and modifying the mounting status of the module.(according to the parameter) Reference flag: Module detach error flag (_IO_DEER, _IO_DEER_N, _IO_DEERR[n])	STOP (RUN)	E031	Scan end
32	Fuse cutoff of fuse built-in module during operation	After checking the position of slot where the fuse cutoff occurs by XG5000, change the fuse and then Restart (according to parameter). Reference flag: FUSE break error flag (_FUSE_ER, _FUSE_ER_N, _FUSE_ERR[n])	STOP (RUN)	E032	Scan end
36	Detach error on extended base	Extended cable detach error	STOP, RUN	E036	Power on, end of scan, during program operation
39	Abnormal stop of CPU or malfunction	A / S request if repeated on power up	-	E039	Power on, scan completion, In operation
40	Scan time of program during operation exceeds the scan	Check the the scan watchdog time time specified by the parameter and after restart after modifying the parameter or program.(Cold)	STOP	E040	In operation

	watchdog time designated by parameter.				
41	Operation error occurs while running the user program.	Remove calculation error-> Redownload program and restart	STOP	E041	In operation

Code	Cause of error	Action (Restart Mode After Action)	Run status	LED status	Diagnostics point
43	Base double setting error	Check Expansion driver ID duplicates	STOP	E043	Power on
45	Base power error	Check power module installation when both power modules are off	STOP, RUN	E045	Power on
48	Module position error	A module that cannot be mounted on the base is mounted. Please refer to the error history for details.	STOP, RUN	E048	Power on, program loading, change RUN mode
50	Detecting critical error of external device by user program during operation	Critical error detection in external device ( <code>_ANNUN_ER,_ANC_ERR[n]</code> ) Repair and restart the wrong device by referring to the fault detection flag(according to the parameter).	STOP, RUN	E050	Scan completion
101	CPU module installation position error	If the CPU module is mounted in an unmountable slot, move it to the correct position to install	STOP	S101	Power on
102	CPU module ID duplicate setting error	Set the CPU module ID setting differently from the counterpart CPU module	STOP	S102	Power on
103	Base abnormal error	Configure the extension cable in a ring topology, and restart the system after configuring the missing base normally. Please refer to Standby CPU error history for its detached base information.	STOP, RUN	E103	In operation
104	System configuration error	Reconfigures Redundant system <ul style="list-style-type: none"> <li>• Check the Expansion driver module station number</li> <li>• Check O / S version between expansion driver module and expansion manager</li> </ul>	STOP	E104	Power on Scan completion
300	Redundant system synchronous operation error	When entering redundant operation or between CPUs during operation Occurs when the program and data are out of sync	STOP	E300	When entering redundant operation or between CPUs during operation
301	Standby CPU run error occurs because of Master CPU error.	When we Restart after by redundant operation <ul style="list-style-type: none"> <li>•Set the standby CPU operation mode to STOP.</li> <li>•Release the master CPU error and restart</li> <li>•Set the standby CPU operation mode to</li> </ul>	STOP	E301	When operating in standby CPU

		<p>RUN.</p> <p>When the standby CPU restarts in standalone operation</p> <ul style="list-style-type: none"> <li>•Stop the master CPU (STOP or power off)</li> <li>•Restart the standby or reset the operation mode to STOP / RUN using the standby switch of the standby CPU.</li> </ul>			
501	Clock data abnormal	If there is no problem with the battery, resetting the time with a device such as XG5000.	RUN	E501	Power on,scan completion
502	Low battery voltage	Battery change with power on	RUN	E502	Power on,scan completion
bxX	Expansion base error	<p>Check Expansion base power</p> <p>Check Expansion base cable</p>	RUN	EbxX	operation

9.2.2 Error / Warning check during communication module operation

By XG5000 program, you can monitor the communication module abnormally. Connect to CPU port and click [Online] → [Communication module setting and diagnosis] → [System diagnosis] of XG5000. Thereafter, you can right-click the Ethernet module in the PLC system and check it through the Block Status tab of [Status by Service] → [P2P Service]. Please refer to E-mail error code when using E-mail service.

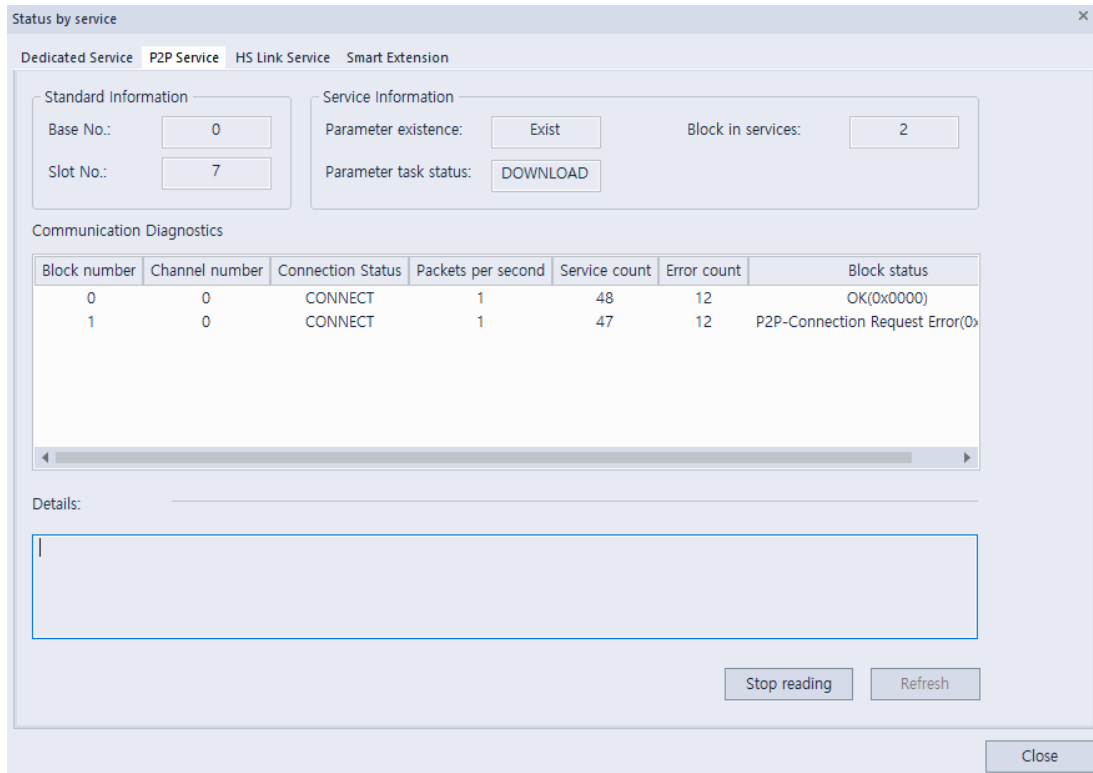

## (1) Error / Warning check during communication module operation(P2P/dedicated service)

Error code	Error contents	Solution
0x0000	Normal operation	-
0x0001	P2P-Communication Error	<p>1) Modbus registration failed in Modbus communication. If the problem persists, please contact our Customer Centre.</p> <p>2) The number of channels in the message in the server service (dedicated communication) exceeded 1 Check the P2P block setting. (Up to 64 channels are supported in V6.0 or higher.)</p> <p>3) Email address error in Email service. Please check your email address</p>
0x0002	P2P-Communication Error	<p>1) Modbus transmission size error occurred in Modbus communication. Check the block setting.</p> <p>2) Data type request error in P2P service. Check the block setting.</p> <p>3) The message to send with the Email address book is not set in the Email service. Check the address and message settings.</p>
0x0003	P2P-Communication Error	<p>1) Device area request error. Check the block setting.</p> <p>2) The server service (dedicated communication) is establishing a connection with the server.</p> <p>3) The number of blocks of XGT Cnet client (Cnet dedicated communication) request message has been exceeded. Check the block setting.</p> <p>4) Email service cannot connect to the email server. Check the IP address, ID, password of the email server and check the network status.</p>
0x0004	P2P-Communication Error	<p>1) The device area requested by the server service (dedicated communication) has been exceeded. Check the block setting.</p> <p>2) An error message was received from the server in Modbus communication. Check the block setting (address, data size, etc.).</p> <p>3) Check the variable length of the XGT Cnet client (Cnet dedicated communication) request message.</p>
0x0005	P2P - Time out error	<p>1) The server service did not receive a response from the server (slave) station within the response wait time. Check the communication settings.</p> <p>When the server service received the response message from the server in time, the server received an error message from the server because it exceeded the maximum size (1400 bytes) of the single block. Check the block setting.</p> <p>Email send failed in the email service. Check the network connection.</p>
0x0006	P2P-Disconnection notification	<p>1) The server service has disconnection with the server (slave station). Check the communication settings and connection status.</p> <p>When the server service received the response message from the server in time, the server received an error message from the server because it exceeded the maximum size (1400 bytes) of the single block. Check the block setting.</p>
0x0007	Server service - Data type error	<p>1) The Cnet client requested a data type that is not supported by the server CPU. Check the block setting.</p> <p>2) It was downloaded without using "E-mail" in Email setup window. Select "Use E-mail" to use.</p>
0x0008	Dedicated Server - Address type error	There is an error in the address format set in XGT Cnet client (Cnet dedicated communication). Check the block setting.
0x0010	P2P-XGT server communication or download error	<p>1) Downloading P2P parameter of XGT dedicated communication.</p> <p>2) There is an error in the data type of the FEnet dedicated communication request message. Check the block setting.</p>

Error code	Error contents	Solution
0x0011	P2P - communication error	1) Data type of Enet dedicated communication request message and direct variable of detail setting do not match Check the block setting. There is an error in the message data requested from XGT Cnet client (Cnet dedicated communication). Check the data. 3) Check the data type of the XGT dedicated communication P2P block.
0x0012	P2P - communication error	1) There is an error in the address format of the FEnet dedicated communication request message. Check the block setting. 2) An error occurred during data transmission of the FEnet dedicated communication. Check the server and network connection.
0x0013	P2P-Request error	P2P block request information of XGT dedicated communication is wrong. If the problem persists, please contact our Customer Center.
0x0015	P2P-Event transmit error	There is a problem with the Ethernet transmission of the XGT dedicated communication. If the problem persists, please contact our Customer Center.
0x0016	P2P-Event receive error	There is a problem with the internal sending logic of the XGT dedicated communication. If the problem persists, please contact our Customer Center.
0x0017	P2P-Connection request error	XGT dedicated communication cannot establish connection with server. Check the communication settings and network connection.
0x0018	P2P-internal transmit frame storage exceeded	The internal transmission frame number of FEnet dedicated communication has been exceeded. Check the communication settings and network connection.
0x0020	Periodic communication block registration error	The periodic communication service has already been registered by another client. Please check the block settings.
0x0021	Periodic communication block range setting error	The periodic communication block is out of the configurable range. Please check the block settings.
0x0022	Periodic communication "start" command error	The registered periodic communication block is already in operation. Please check the block settings.
0x0023	Periodic communication "STOP" command error	There are no registered periodic communication blocks. Please check the block settings.
0x0024	Periodic communication "DELETE" command error	There are no registered periodic communication blocks. Please check the block settings.
0x0030	CoS registration error	CoS(Change of status) communication service has already been registered by another client. Please check the block settings.
0x0031	CoS communication block range setting error.	The CoS (Change of status) communication block is out of the configurable range. Please check the block settings.
0x0032	CoS communication "start" command error	The registered CoS communication block is already in operation. Please check the block settings.

Error code	Error contents	Solution
0x0033	CoS communication "STOP" command error	There are no registered CoS communication blocks. Please check the block settings.
0x0034	CoS communication "DELETE" command error	There are no registered CoS communication blocks. Please check the block settings.
0x0051	P2P-Exceeded maximum number of connection	The maximum number of connections that can be connected to XGT dedicated communication has been exceeded. Check the number of connections. If the problem persists, please contact our Customer Center.
0x0062	P2P-Channel error	There is an error in the channel set in XGT dedicated communication. Check the channel settings.
0x0075	P2P-Received XGT dedicated error reply message	The CompanyID is set incorrectly in the request Message header for FEnet dedicated communication. Check the settings.
0x0076	P2P-Received XGT dedicated error reply message	The size of the request Message header for FEnet dedicated communication is incorrect. Check the settings.
0x0077	P2P-Received XGT dedicated error reply message	Checksum in the request Message header of FEnet dedicated communication is set incorrectly. Check the settings.
0x0078	P2P-Received XGT dedicated error reply message	The command Message header of FEnet dedicated communication is set incorrectly. Check the settings.
0x0090	Dedicated Server - Monitor execution error	there is a problem in monitor execution registration request of XGT Cnet client (Cnet dedicated communication). Check the settings.
0x00F0	P2P-Buffer Error	There was a problem when allocating an internal buffer for FEnet dedicated communication. If the problem persists, please contact our Customer Centre.
0x0190	Dedicated Server - Monitor execution register number error	The monitor registration number to be executed by XGT Cnet client (Cnet dedicated communication) has exceeded the maximum value Check the settings.
0x0290	Dedicated Server - Monitor registration error	The monitor registration number to be executed by XGT Cnet client (Cnet dedicated communication) has exceeded the maximum value Check the settings.
0x1132	Dedicated Server - Device type error	The XGT Cnet client (Cnet dedicated communication) attempted to access a device area that is not supported by the server CPU. Check the settings.
0x1232	Dedicated Server - Data size error	The maximum data size (120Byte) that can be requested in XGT Cnet client (Cnet dedicated communication) is exceeded. Check the settings.
0x1234	Dedicated Server - Extra frame error	XGT Cnet client (Cnet dedicated communication) has exceeded the designated data size of the server. Check the settings.
0x1332	Dedicated Server - Data type mismatch	There is an error in data type of single read / write in XGT Cnet client (Cnet dedicated communication). Check the settings.
0x1432	Dedicated Server - HEX conversion error	XGT Cnet client (Cnet dedicated communication) received hexa conversion error message from server. Check the settings.
0x5D52	P2P-Email parameter download error	It was downloaded without using "E-mail" in Email setup window. Select "Use E-mail" to use.

Error code	Error contents	Solution
0x7132	Dedicated Server - Excess of variable requested area error	The device area requested by XGT Cnet client (Cnet dedicated communication) has been exceeded. Check the settings.
0x8123	Server timeout error	The communication module sent a message to the CPU, but there was no response. Please try increasing the communication cycle.
0x8124	Drop request message	The communication module sent a message to the CPU, but the QUEUE was full and the message was dropped. Please try increasing the communication cycle.
0xB001	P2P - Data type error	Check the block data type in XGT Cnet client (Cnet dedicated communication).
0xB002	P2P - Driver type error	P2P driver type is not set in XGT Cnet client (Cnet dedicated communication) Check if the basic parameter is set to P2P and driver type of P2P channel setting.
0xB003	P2P - Command type error	An unsupported P2P instruction was attempted in the XGT Cnet client (Cnet dedicated communication). Check the block setting.
0xB004	P2P - Block number error	The block number settable in XGT Cnet client (Cnet dedicated communication) has been exceeded. Check the P2P parameter.
0xB005	P2P - Segment error	There is an error in the User frame definition parameter in XGT Cnet client (Cnet dedicated communication). Check the parameter.
0xB006	P2P - Block size error	Check the block size setting in XGT Cnet client (Cnet dedicated communication).
0xB007	P2P - Function type error	In XGT Cnet client (Cnet dedicated communication), unsupported function code is used. Check the block setting.
0xB008	P2P - Block station number setting error	The maximum station number was exceeded in XGT Cnet client (Cnet dedicated communication). Check the block setting.
0xB025	P2P - Received incorrect response frame for the request.	It is not a response to the frame requested from XGT Cnet client (Cnet dedicated communication). Check the server settings.
0xB026	P2P - Received delayed response	Delayed response frame was received from XGT Cnet client (Cnet dedicated communication). Check the Reception waiting time
0xE001	P2P-Process error	There is a problem with the client internal logic in FEnet dedicated communication. If the problem persists, please contact our Customer Centre.
0xE004	P2P - Driver type error	P2P driver type is not set in FEnet dedicated communication. Check driver type of P2P channel setting.
0xE005	P2P - Command type error	P2P command not supported in FEnet dedicated communication was requested. Check the block setting.
0xE006	P2P - Data type error	Incorrect data type in FEnet dedicated communication. Check data type
0xE007	P2P-Request buffer full	FEnet dedicated communication is unable to process the requested data. Check the server and network connection.
0xE020	P2P-User defined server transmit error	In user frame definition communication, the server cannot send data before making a connection. First, establish a connection on the other client.

Error code	Error contents	Solution
0xE022	P2P-Connecting	FEnet has a connection with a server in dedicated / user frame definition communication.
0xE024	P2P-XGT dedicated protocol transmit error	An error occurred during data send in FEnet dedicated communication. Check the network connection.
0xE025	P2P-Modbus protocol transmit error	An error occurred during Modbus data send during Modbus communication. Check the network status.
0xE026	P2P-User frame definition send error	An error occurred during data transmission in user frame definition communication. Check the server and network connection.
0xE027	P2P - Transmission error	An error occurred during data send in FEnet dedicated communication. Check the network connection.
0xE060	P2P-User defined protocol size error	The data size set in user frame definition communication exceeded the maximum size (1024byte). Adjust the data size
0xE170	P2P-Email parameter download error	It was downloaded without using "E-mail" in Email setup window. Select "Use E-mail" to use.
0xE171	P2P-Email parameter setting error	It was downloaded without using "E-mail" in Email setup window. Select "Use E-mail" to use.
0xE172	P2P-Email address list or message download error	There are no messages to send with the Email address book. Check the address and message setting on XG5000 and try again.
0xE173	P2P-Email receiver registration error	An error occurred while registering the email receiver. Check the settings.
0xE174	P2P-Email sender registration error	An error occurred while registering the email sender. Check the settings.
0xE175	P2P-Email initialization error	An error occurred initializing the Email driver. If the problem persists, please contact our Customer Centre.
0xE176	P2P-Email address error	Wrong type of Email address requested. Please check your email address(Group or individual).
0xE177	P2P-Email message type error	An invalid email message type was requested. Check the type of email message.
0xE178	P2P-Email server connection error	Can not connect to the Email server. Check the IP address, ID, password of the email server and check the network status.
0xE179	P2P-Email sending error	Email send failed in the email service. Check the communication connection status.
0xFFD7	P2P- Data sending buffer Full	FEnet dedicated communication is unable to process the requested data. Check the communication connection status.
0xFFEB	P2P- internal interlock error	There is a problem with the client internal logic in FEnet dedicated communication. If the problem persists, please request A / S.
0xFFFF	P2P-Error	1) In user frame definition communication, the server cannot send data before making a connection. First, establish a connection on the other client. 2) The data size set in user frame definition communication exceeded the maximum size (1024byte). Check the data size

Note1) FEnet dedicated communication collectively refers to **XGT server** and **XGT Enet client**

Note2) XGT dedicated communication is collectively called **FEnet dedicated communication** and **Cnet dedicated communication**.

(2) Error / Warning check during communication module operation(Smart Extension Service)

By XG5000 program, you can monitor the communication module abnormally. Connect to CPU port and click [Online] → [Communication module setting and diagnosis] → [System diagnosis] of XG5000. Thereafter, you can right-click the Ethernet module in the PLC system and check it through the Block Status tab of [Status by Service] → [Smart Extension].

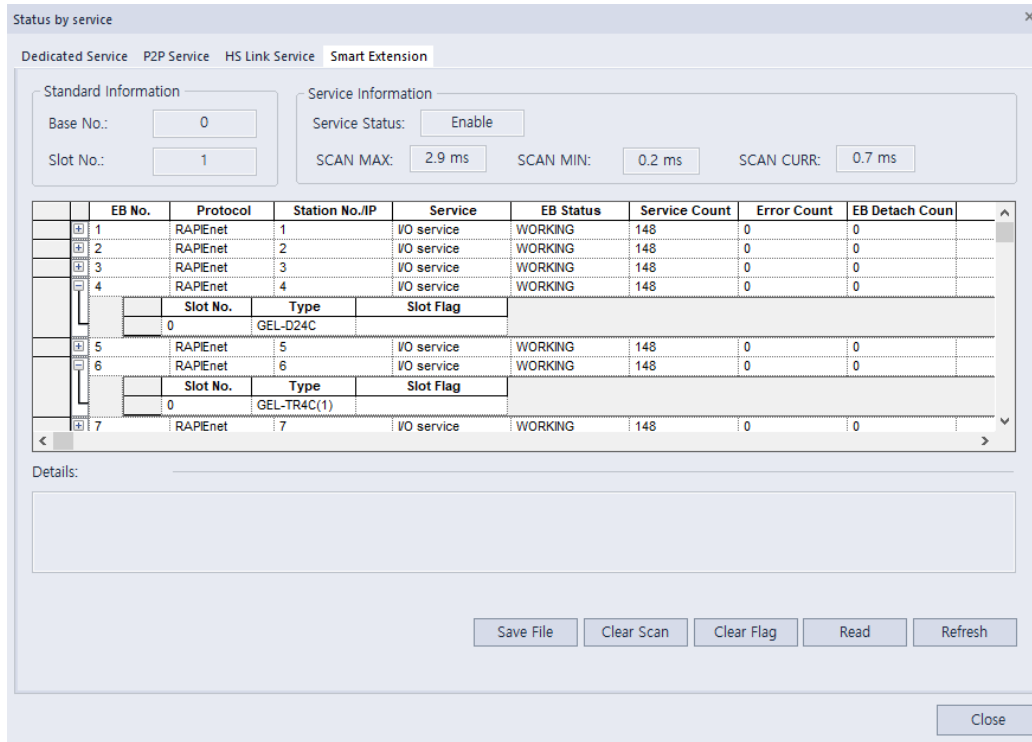

Describes each item on the screen above

Item	Contents						
Base Number	Displays the base number on which the Ethernet module is mounted.						
Slot No.	Displays the slot number on which the Ethernet module is mounted.						
Service status	Displays the enabled status of the Smart extension service. - Types of service status and descriptions are as follows. <table border="1" style="width: 100%; border-collapse: collapse;"> <thead> <tr> <th>Service status type</th> <th>Description</th> </tr> </thead> <tbody> <tr> <td>Enable</td> <td>Smart extension service is working.</td> </tr> <tr> <td>Disable</td> <td>The operation of the Smart extension service has stopped.</td> </tr> </tbody> </table>	Service status type	Description	Enable	Smart extension service is working.	Disable	The operation of the Smart extension service has stopped.
Service status type	Description						
Enable	Smart extension service is working.						
Disable	The operation of the Smart extension service has stopped.						
SCAN MAX	Smart extension service displays the maximum scan cycle of the network.						
SCAN MIN	Smart extension service displays the minimum scan cycle of the network.						
SCAN CURR	Smart extension service displays the current scan cycle of the network.						
EB No.	Displays the EB number of the communication device.						
Protocol	Displays the protocol type used for connection with the communication device.						
Station No/IP	Displays the station number / IP of the communication device. - Displays the station number when the protocol type is RAPIEnet. - Displays the IP address when the protocol type is EtherNet / IP.						
Service	Displays currently active services. - I/O service: Service provided by communication device with Smart Extension function - Event service: EtherNet / IP Client Service						

Item	Contents	
EB status	Displays the current EB status.	
	Service status	Description
	IDLE	The communication device (slave) to be controlled is not recognized in the network.
	DETECTING	Looking for communication device (slave).
	STATE_CFM	The communication device has been checked.
	PRM_DONE	Parameter download has been completed to the communication device.
	IO_PRM_MISS_MATCH	The I / O list of the reserved parameters and the I / O list installed in the communication device are different.
	WORKING	It is a state that normally performs Smart extension service.
DETACH	The Communication device is detached during the control.	
Service count	Displays the service operation counts currently.	
Error count	Displays the count of errors that have occurred currently.	
EB detachment count	Displays the EB detachment counts that have occurred currently.	
EB flag	Flag is displayed according to the type of error occurred when an error occurs in EB.	
Slot No. (slot)	Displays the slot number (EB).	
Type(slot)	Displays the module type installed in the slot (EB). - For EtherNet / IP EIP ) clients, displays the service type.	
Status(slot)	Displays the service status of the slot (EB).	
Block Status(slot)	Display the status of that service block. - This feature is only available for EIP clients.	
Error code (Slot)	The error code of the service is displayed. - This feature is only available for EIP clients.	
Service count(slot)	The service count of the service is displayed. - This feature is only available for EIP clients.	
Error count(Slot)	The error count of the service is displayed. - This feature is only available for EIP clients.	
Slot flag (slot)	Flag is displayed according to the type of error occurred when an error occurs in slot.	
File save	Saves the current status of Smart extension service as a file.	
Clear scan	Initializes the scan information. Initializes the SCAN MAX and SCAN MIN values.	
Clear flag	Initialize the EB flag and slot flag (slot). - Error flag history is initialized.	
Continuous reading	Smart extension service status is updated continuously.	

(3) Diagnostic variables during communication module operation(Smart Extension Service)

Smart extension service can check error-related diagnostic variable (EB flag) in diagnosis variable and Status by Service. See the table below for the corrective actions for the errors identified in the diagnostic variables (EB flags). If the same error occurs after the measures below, request A / S.

Smart Extension		Format: <span>Hexadecimal</span> <span>Variable Setting</span> <span>Synchronize</span>						
EB No.	Station No/IP	Variable Kind	Variable name	Type	Device	Monitor value	Comment	
1	EB00	System diag						
2			_0001_STATUS_CHG_CNT	UINT	D01500		스마트 중설 네트워크 상태 변경 횟	
3			_0001_SCAN_MAX	UINT	D01501		스마트 중설 최대 스캔 주기 (100us)	
4			_0001_SCAN_MIN	UINT	D01502		스마트 중설 최소 스캔 주기 (100us)	
5			_0001_SCAN_CUR	UINT	D01503		스마트 중설 현재 스캔 주기 (100us)	
6			_0001_SYSTEM_ER	BIT	D01504.0		스마트 중설 전체 EB 예러	
7			_0001_SYSTEM_WAR	BIT	D01504.1		스마트 중설 일부 EB 예러	
8			_0001_EB_DEER	BIT	D01504.2		스마트 중설 운전 중 EB 탈락	
9			_0001_EB_BASE_INFO_ER	BIT	D01504.3		스마트 중설 베이스 정보 예러	
10			_0001_IO_TYER	BIT	D01504.4		스마트 중설 IO 타입 예러	
11			_0001_IO_DEER	BIT	D01504.5		스마트 중설 IO 탈락 예러	
12			_0001_FUSE_ER	BIT	D01504.6		스마트 중설 IO FUSE 예러	
13			_0001_REF_TIME_OUT	BIT	D01504.7		스마트 중설 리프레시 타임 아웃	
14			_0001_EB_CRC_ER	BIT	D01504.8		스마트 중설 EB CRC 예러 프레임 수	
15			_0001_TAG_ER	BIT	D01504.9		스마트 중설 태그 불일치 예러	
16			_0001_EB_CFG_ER	BIT	D01504.A		스마트 중설 EB 구성 예러	
17			_0001_EB_DETACH_WAR	BIT	D01504.B		스마트 중설 운전중 EB탈락 경고(핫)	
18			_0001_IO_DETACH_WAR	BIT	D01504.C		스마트 중설 운전중 IO탈락 경고(핫)	
19			_0001_FUSE_WAR	BIT	D01504.D		스마트 중설 운전중 FUSE 경고(핫스)	
20			_0001_STATUS_CHG_CNT_CLR	BIT	D01505.B		스마트 중설 네트워크 상태 변경 횟	
21			_0001_REF_TIME_OUT_CLR	BIT	D01505.C		스마트 중설 리프레시 타임 아웃 초	
22			_0001_EB_CRC_ER_CLR	BIT	D01505.D		스마트 중설 EB CRC 예러 프레임 수	
23			_0001_SCAN_CLR	BIT	D01505.E		스마트 중설 스캔 정보 초기화	
24			_0001_FLAG_CLR	BIT	D01505.F		스마트 중설 플래그 정보 초기화	
25			_0001_EB_ER_W0	WORD	D01506		스마트 중설 EB 예러 EB00 ~ EB15	
42			_0001_EB_ER_W1	WORD	D01507		스마트 중설 EB 예러 EB16 ~ EB31	
59			_0001_EB_ER_W2	WORD	D01508		스마트 중설 EB 예러 EB32 ~ EB47	
76			_0001_EB_ER_W3	WORD	D01509		스마트 중설 EB 예러 EB48 ~ EB63	

Diagnostic variables	Variable name	Corrective Measure
System diagnosis	_BBSS_SYSTEM_ER	<p>Check the network connection.</p> <p>1) System check including smart extension network cable</p> <p>2) Check the power status of devices in the network</p> <p>* Allocate diagnostic variables depend on the setting of the EB or module swap(hot swap) option during operation. For more information, refer to '4.4.3 Diagnosis Variable Action by EB or Module Change (Hot Swap) Option'.</p>
	_BBSS_SYSTEM_WAR	<p>Check the network connection.</p> <p>1) System check including smart extension network cable</p> <p>2) Check the power status of devices in the network</p> <p>Allocate diagnostic variables depend on the setting of the EB or module swap(hot swap) option during operation. For more information, refer to '4.4.3 Diagnosis Variable Action by EB or Module Change (Hot Swap) Option'.</p>
	_BBSS_EB_DEER	<p>Check the network connection.</p> <p>1) System check including smart extension network cable</p> <p>2) Check the power status of devices in the network</p> <p>Allocate diagnostic variables depend on the setting of the EB or module swap(hot swap) option during operation. For more information, refer to '4.4.3 Diagnosis Variable Action by EB or Module Change (Hot Swap) Option'.</p>
	_BBSS_EB_BASE_INFO_ER	<p>Check the EB diagnostic variable and reapply the power to the EB where _BBSS_EBXX_BASE_INFO_ER occurred.</p>
	_BBSS_IO_TYER	<p>Check the EB diagnostic variable to see if the I / O parameter setting value of the communication device where _BBSS_EBXX_IO_TYER occurred matches the type of I / O module installed.</p>
	_BBSS_IO_DEER	<p>Check I / O module status of the communication device for which _BBSS_EBXX_IO_DEER occurred by checking the EB diagnostic variable.</p> <p>1) Check if I / O module is missing from communication device</p> <p>2) Check if I / O module failure of communication device</p> <p>* Allocate diagnostic variables depend on the setting of the EB or module swap(hot swap) option during operation. For more information, refer to '4.4.3 Diagnosis Variable Action by EB or Module Change (Hot Swap) Option'.</p>

Diagnostic variables	Variable name	Corrective Measure
System diagnosis	_BBSS_FUSE_ER	Replace I / O module where the FUSE error occurred among the I / O modules of the communication device.
	_BBSS_REF_TIME_OUT	Check the EB diagnostic variable to check the communication device for which _BBSS_EBXX_REF_TIME_OUT has occurred. See Actions in EB Diagnostic Variables for action.
	_BBSS_EB_CRC_ER	Check the network connection. 1) System check including smart extension network cable 2) Check the connection between the network cable and the module
	_BBSS_TAG_ER	Download EtherNet / IP tag (EIP tag) to XGL-EFMxB module for smart extension service operation.
	_BBSS_EB_CFG_ER	Check the status of EB set in the smart expansion service. 1) Check the EB network detachment 2) Check the Status of the EB error
	_BBSS_EB_DETACH_WAR	During operation, check the network connection for EB that have EB or module swap (hot swap) settings enabled. 1) System check including smart extension network cable 2) Check the power status of devices in the network  * This diagnostic variable reflects only the status of EB or EB with module exchange (hot swap) setting enabled during operation.
	_BBSS_IO_DETACH_WAR	Check the I/O module status of the communication device where _BBSS_EBXX_IO_DEER occurred by checking the EB diagnostic variables of EB that have EB or module exchange (hot swap) setting enabled during operation. 1) Check if I / O module is missing from communication device 2) Check if I / O module failure of communication device  * This diagnostic variable reflects only the status of EB or EB with module exchange (hot swap) setting enabled during operation.

Diagnostic variables	Variable name	Corrective Measure
System diagnosis	_BBSS_FUSE_WAR	<p>During operation, replace the I/O module that has a FUSE error among the I/O modules of the EB or EB with module exchange (hot swap) setting enabled.</p> <p>* This diagnostic variable reflects only the status of EB or EB with module exchange (hot swap) setting enabled during operation.</p>
	_BBSS_EB_ER	<p>Check the diagnostic variable or EB flag of EB corresponding to the WORD value where the error occurred.</p> <p>Allocate diagnostic variables depend on the setting of the EB or module swap (hot swap) option during operation. For more information, refer to '4.4.3 Diagnosis Variable Action by EB or Module Change (Hot Swap) Option'.</p>
	_BBSS_EB_WAR	<p>Check the diagnostic variable or EB flag of EB corresponding to the ARRAY value where the warning occurred.</p>

Diagnostic variables		Variable name	Corrective Measure
EB Diagnosis	EB diagnostics	_BBSS_EBXX_CFG_ER	- At service initialization (including power up) 1) System check including smart extension network cable 2) Check the power state of the corresponding communication device - 'Write' during service operation 1) See action for IO_TYER (concurrent with IO_TYER)
		_BBSS_EBXX_DEER	Check the network connection. 1) System check including smart extension network cable 2) Check the power status of devices in the network
		_BBSS_EBXX_REF_TIME_OUT	- Check the network connection of the relevant communication device 1) System check including smart extension network cable 2) Check the power status of devices in the network - Check the network load of the relevant communication device. 1) Check if the network load meets the specifications of the product. Refer to '2.2.3 Load Specification' for load specification and checking method. * REF_TIME_OUT may occur when the smart extension service does not operate normally due to other errors. * When REF_TIME_OUT occurs, _BBSS_EB_WAR occurs, and the error counter of the corresponding EB is increased in the Smart extension tab of the service status. * If REF_TIME_OUT occurs consistently, EB detach (_BBSS_EB_DEER, _BBSS_EBXX_DEER) occur.
		_BBSS_EBXX_P1_CRC_ER	Check the network connection of PORT 1 of the corresponding communication device. 1) System check including smart extension network cable 2) Check the connection between the network cable and the module

Diagnostic variables		Variable name	Corrective Measure
EB Diagnosis	EB diag nosti cs	_BBSS_EBXX_P2_CRC_ER	Check the network connection of PORT 2 of the corresponding communication device. 1) System check including smart extension network cable 2) Check the connection between the network cable and the module
		_BBSS_EBXX_BASE_INF_O_ER	Reapply power to the communication device.
		_BBSS_EBXX_IO_TYER	Check that the I / O parameter settings of the communication device and the mounted I / O module match.
		_BBSS_EBXX_IO_DEER	Check I / O module status of the corresponding communication device. 1) Check if I / O module is missing from communication device 2) Check if I / O module failure of communication device
		_BBSS_EBXX_FUSE_ER	Replace I / O module where the FUSE error occurred.
	Slot	_BBSS_EBXX_SYY_IO_TYER	Check that I / O parameter settings of the communication device and the mounted I / O module match.
		_BBSS_EBXX_SYY_IO_DEER	Check I / O module status of the communication device. 1) Check if I / O module is missing from communication device 2) Check if I / O module failure of communication device
		_BBSS_EBXX_SYY_FUSE_ER	Replace I / O module.
		_BBSS_EBXX_SYY_SVC_ER	Check EtherNet / IP communication settings.

### 9.2.3 View Communication Module Log

Communication module history view function of XG5000 program can check whether error occurred and measures. Select [Online] → [Communication module setting] → [System Diagnosis] from XG5000. Right-click on the XGL-EFMxB module you want to diagnose and select [View communication module log]. If you select the error occurrence history in the [Event History] tab and the [Communication History] tab, you can check the details of the error and the corrective action in "Details and Actions" below.

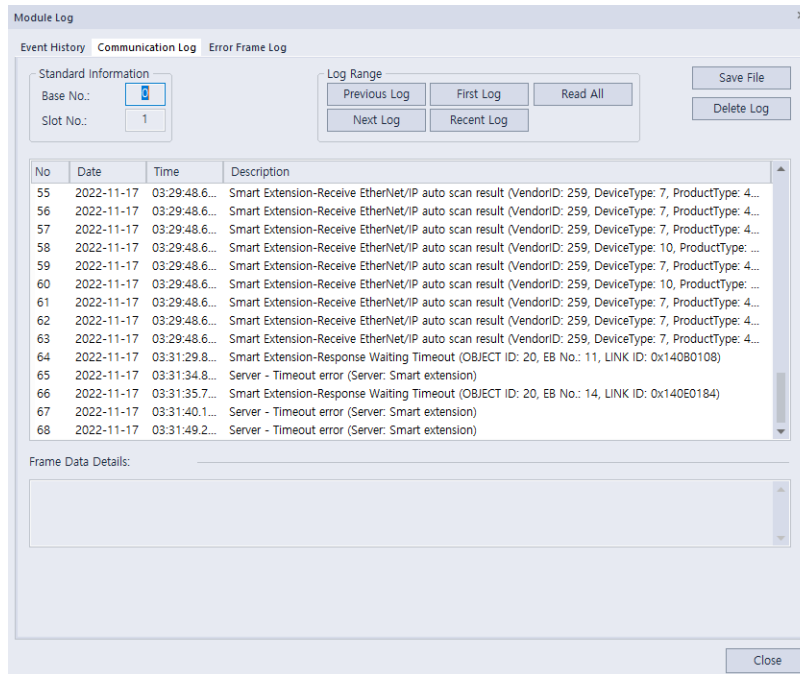

If you press [Frame Capture (C)] in the [Frame History] tab, you can start/stop frame capture, and if you read the history, you can see the communication frame at the start-stop point. If you press [Save File (S)], it is saved as a txt file and can be imported from "wireshark".

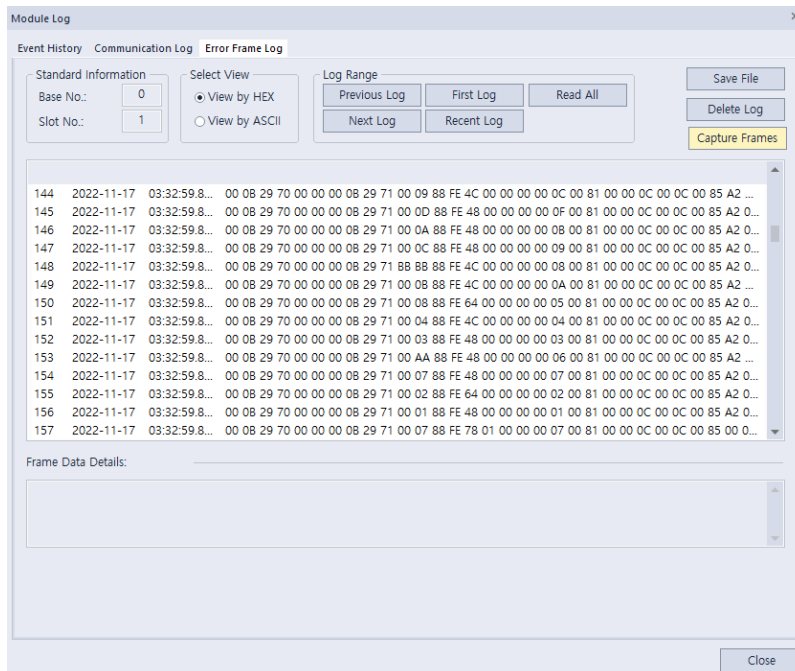

9.3 XGT dedicated communication error code

9.3.1 STATUS value that can be checked in communication frame

This is an error code that responds when an error occurs for a request for XGT dedicated communication beginning with "LSIS-XGT" or "LGIS-GLOFA".

The error code can be checked in the error code area of the NAK message.

Format Name	Header	Command	Data type	Reserved area	Error Status	Error code (Hex 2 Byte)
Code(ex)	...	h'0055	h'0002	h'0000	h'FFFF or h'00FF (Non-zero value)	h'0004

```

0000 00 e0 91 02 00 21 00 e0 91 03 12 93 08 00 45 00 .....!.. .....E.
0010 00 46 00 03 00 00 80 06 b8 96 c0 a8 00 5a c0 a8 .F.....Z..
0020 00 6e 07 d4 bb 52 01 91 8e e7 dc 6c 5c e3 50 18 .n...R.. ...|\.P.
0030 3e 80 3c a3 00 00 4c 53 49 53 2d 58 47 54 00 00 >.<...LS IS-XGT..
0040 01 01 a0 11 00 00 0a 00 04 1c 55 00 14 00 00 00 .....U.....
0050 ff 00 04 00
    
```

Error number		Description
Decimal	HEX	
1	0x0001	The number of blocks exceeded 16 in single read / write requests.
2	0x0002	Received a data type other than X, B, W, D, L.
3	0x0003	If you request a device that is not in service. (XGK: P, M, L, K, R..., XGI: I, Q, M....)
4	0x0004	It is the case that exceeded the supported area for each device.
5	0x0005	Read / write up to 1400 bytes at a time, if you request beyond this range.(Single block size)
6	0x0006	Read / write up to 1400 bytes at a time, if you request beyond this range.(Total size per block)
117	0x0075	The head of the frame header in the dedicated service is invalid ('LSIS-GLOFA')
118	0x0076	The length of the frame header in the dedicated service is invalid
119	0x0077	The Checksum of the frame header in the dedicated service is invalid
120	0x0078	Incorrect command in dedicated service.

Notes

(1) When checking the value on the frame, the upper and lower bytes of the hexadecimal word data are swapped and displayed. (Difference according to Endian)

Ex) h'0054 ⇒5400

9.4 Troubleshooting by error

Trouble shooting method is to check the error history in XG5000 and LED status of Ethernet module and then take measures.

9.4.1 Troubleshooting

(1) Turn off the Run LED on the Ethernet module: hardware error

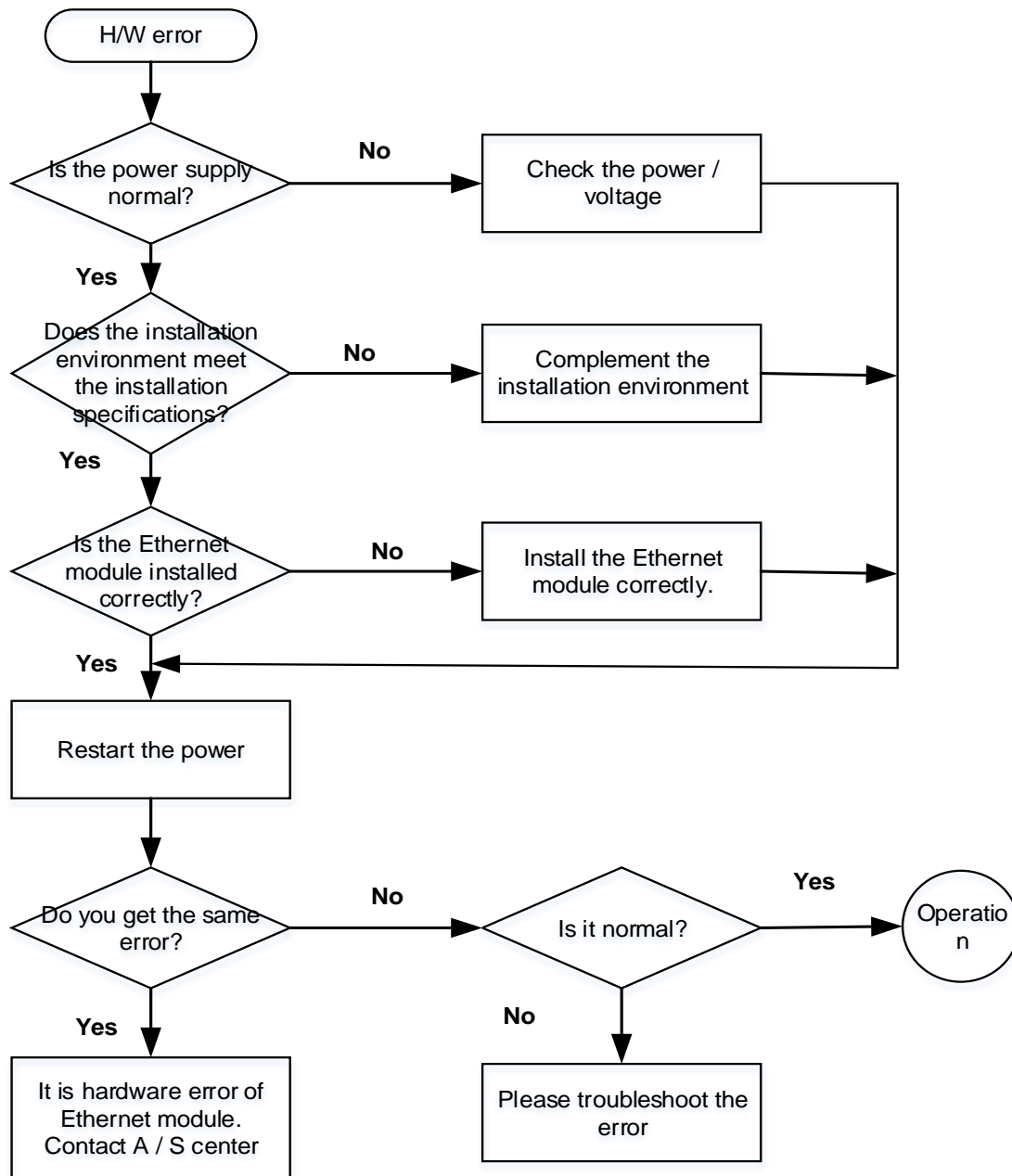

(2) I / F LEDs on the Ethernet Module do not flash: Interface error

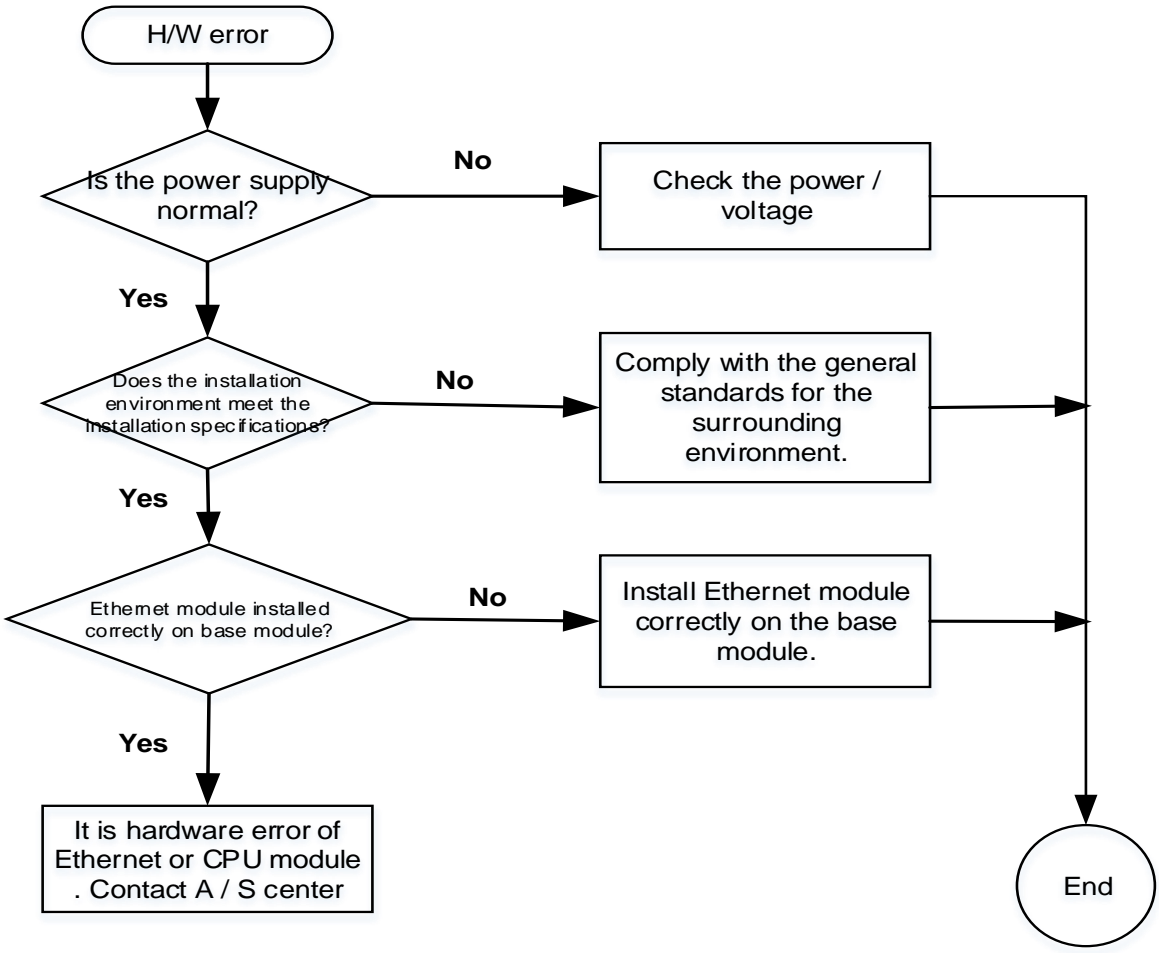

## Chapter 10 EMC Standard

### 10.1 The requirements for compliance with EMC standards

The EMC Directive specifies the products must 'be so constructed that they do not cause excessive electromagnetic interference (emissions) 'and 'are not unduly affected by electromagnetic interference (immunity)'. The applicable products are requested to meet these requirements. This section summarizes the precautions on conformance to the EMC Directive of the machinery assembled using XGT PLC series. The details of these precautions are based on the requirements and the applicable standards control. However, LSIS will not guarantee that the overall machinery manufactured according to these details conforms to the below-described directives. The method of conformance to the EMC directive and the judgment on whether or not the machinery conforms to the EMC Directive must be determined finally by the manufacturer of the machinery

#### 10.1.1 EMC Standard

The standards applicable to the EMC Directive are listed below.

Specifications	Test item	Test details	Standard value
EN50081-2	EN55011 Radiated noise * 2	Electromagnetic emissions from the product are measured	30~230 MHz QP: 50 dB $\mu$ V/m * 1 230~1000 MHz QP: 57 dB $\mu$ V/m
	EN55011 Conducted EM noise	Electromagnetic emissions from the product to the power line is measured.	150~500 kHz QP:79 dB Mean: 66 dB 500~230 MHz QP : 73 dB Mean: 60 dB
EN61131-2	EN61000-4-2 Electrostatic immunity	Immunity test in which static electricity is applied to the case of the equipment	15 kV Aerial discharge 8 kV Contact discharge
	EN61000-4-4 Fast transient burst noise	Immunity test in which burst noise is applied to the power line and signal lines	Power line: 2 kV Digital I/O: 1 kV Analog I/O, signal lines: 1 kV
	EN61000-4-3 Radiated field AM modulation	Immunity test in which field is irradiated to the product	10Vm,26~1000 MHz 80%AM modulation@ 1 kHz
	EN61000-4-12 Damped oscillatory wave immunity	Immunity test in which a damped oscillatory wave is superimposed on the power line	Power line: 1 kV Digital I/O (24V or higher): 1 kV

\* 1: QP: Quasi-peak value, Mean: Average value

\* 2: The PLC is an open type device (device installed to another device) and must be installed in a conductive control panel. The test was conducted while installed in the panel.

### 10.1.2 Panel

The PLC is an open type device (device installed to another device) and must be installed in a control panel. This is because an accident such as electric shock does not occur when a person comes into contact with the product (XGT PLC), and the noise generated in the PLC has the effect of attenuating the control panel.

In the case of XGT PLC, it is necessary to install on a metal control panel in order to suppress electromagnetic waves (EMI) emitted from the product.

The specifications for the control panel are as follows.

#### (1) Control Panel

The PLC control panel must have the following features

- 1) Use SPCC (Cold Rolled Mild Steel) for the control panel
- 2) The steel plate should be thicker than 1.6mm.
- 3) Use isolating transformers to protect the power supply from external surge voltage.
- 4) The control panel must have a structure which the radio waves does not leak out. For example, make the door as a box-structure so that the panel body and the door are overlapped each other. This structure reduces the surge voltage generate by PLC.

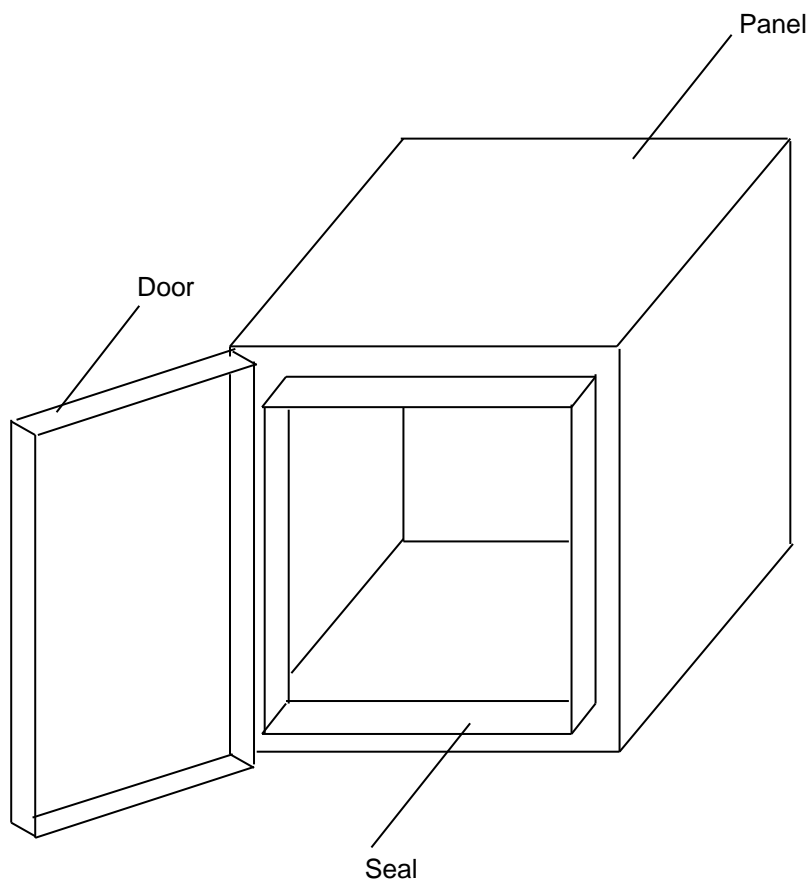

- 5) To ensure good electrical contact with the control panel or base plate, mask painting and weld so that good surface contact can be made between the panel and plate.

#### (2) Power and Earth Wiring

Earthing and power supply wires for the PLC system must be connected as described below.

- 1) Earth the control panel with a thick wire so that a low impedance connection to ground can be ensured even at high frequencies.
- 2) The function of LG (Line Ground) and FG (Frame Ground) terminals is to pass the noise generated in the PLC system to the ground, so an impedance that is as low as possible must be ensured.
- 3) The earthing wire itself can generate the noise, so wire as short and thick to prevent from acting as an antenna.

**10.1.3 Cable**

(1) Extension cable processing

High-speed electrical signals flow through the extension cables of the XGT series. Therefore, high frequency noise waves are radiated from this extension cable. To ensure CE conformity, attach ferrite cores as shown below to the extension cable.

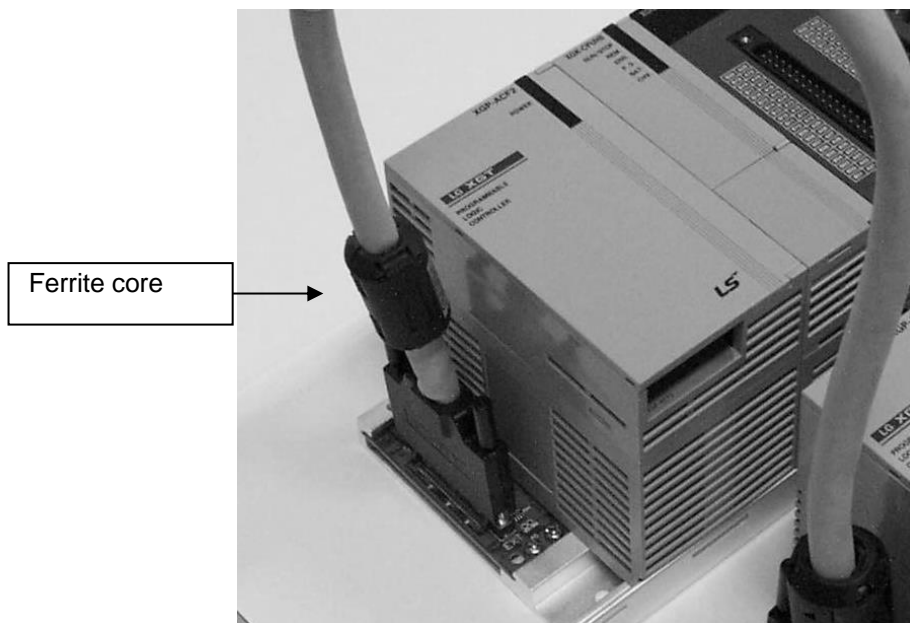

Type	Vendor	Note
CU1330D	E tech	-
ZCAT3035-1330	TDK	-

(3) How to fix the cable in the panel

When fixing the extension cable of the XGT series to the metal control panel, keep the extension cable at least 1 cm so that the extension cable does not directly contact the metal plate. The metal plate of the control panel has a shielding effect that blocks noise from radio waves, but it can also be a good antenna if a cable that is a source of noise is connected nearby. The transmission cable for high speed signals, not limited to the extension cable, needs to be kept as far as possible from the metal plate of the control panel

## 10.2 Requirement to conform the Low-voltage Directive

The low-voltage directive requires each device that operates with the power supply ranging from 50V to 1000VAC and 75V to 1500VDC to satisfy the safety requirements. Cautions and installation and wiring of the series PLC XGT series to conform to the low-voltage directive are described in this section. However, LSIS will not guarantee that the overall machinery manufactured according to the details conforms to the below-described directives. The method of conformance to the EMC directive and compliance to the EMC Directive must be determined by the manufacturer of the machinery.

### 10.2.1 Standards applicable to XGT series

The XGT PLC complies with EN6100-1 (safety of equipment used in measurement and control laboratories. XGT series PLCs have been developed in accordance with the above standards for modules operating at rated voltage of AC50V / DC75V or higher.

### 10.2.2 Selection of XGT Series PLC

#### (1) Power supply module

There are dangerous voltages (higher than 42.4V peak) inside the power supply modules of the Rated input voltage AC110/220Vtes. Therefore, the CE mark-compliant models feature enhanced insulation strong primary and secondary windings.

#### (2) I/O Module

There are dangerous voltages (voltages higher than 42.4V peak) inside the I/O modules of the AC110/220V rated I/O voltages. Therefore, the CE mark-compliant models are enhanced in insulation internally between the primary and secondary.

The I/O modules of DC24V Rated input are out of the low-voltage directive application range.

#### (3) CPU module ,base

Since the above modules use DC5V and 3.3V circuits internally, they are not subject to the low voltage command.

#### (4) Special, Communication module

Special and communication modules are DC24V or less in rated voltage, therefore they are out of the low-voltage directive application range.

## Appendix

### A.1 XGT CPU memory device list

For the latest CPU type devices, refer to the CPU manual. Also, for CPU models released after the writing of this manual, please refer to the relevant CPU manual.

#### A.1.1 XGK CPU devices

Memory area of the CPU used for local data send / receive.

Local Device Type	Range	Size (Word)	Read/Write
P	P0 - P2047	2048	R/W
M	M0 - M2047	2048	R/W
K	K0 - K2047	2048	R/W
F	F0 - F1023	1024	R
F	F1024 - F2047	1024	R/W
T	T0 - T2047	2048	R/W
C	C0 - C2047	2048	R/W
U	U00.00 - U7F.31	4096	R/W
Z	Z0 - Z127	128	R/W
L	L0 - L11263	11264	R/W
N	N0 - N21503	21504	R/W
D(CPUH)	D0 - D32767	32768	R/W
D(CPUS)	D0 - D19999	20000	R/W
R	R0 - R32767	32768	R/W
ZR	ZR0 -ZR65535	65536	R/W

## A.1.2 XGI CPU devices

Device Type		Size	Range	Note	
Data memory	Symbolic variable area(A)	512K byte	%AW0~%AW262143	Up to 256K byte retainable	
	Input variable(I)	16K byte	%IW0.0.0 ~ %IW127.15.3	-	
	Output variable(Q)	16K byte	%QW0.0.0 ~ %QW127.15.3	-	
	Direct Variable	M	256K byte	%MW0~%MW131071	Up to 128K byte retainable
		R	64K byte * 2 Block	%RW0~%RW32767	64K bytes per block
		W	128K byte	%WW0~%WW65535	-
	Flag variable	F	4K byte	%FW0~%FW2047	System flag
		K	16K byte	%KW0~%KW8399	PID flag
		L	22K byte	%LW0~%LW11263	High speed link flag
		N	42K byte	%NW0~%NW25087	P2P flag
U		8K byte	%UW7.15.31	Analog refresh flag	

## A.1.3 XGR CPU devices

Local Device Type		Size	Range	Note	
Memory	Input variable(I)	16KB	%IW0.0.0 ~ %IW127.15.3	-	
	Output variable(Q)	16KB	%QW0.0.0 ~ %QW127.15.3	-	
	Automatic Variable(A)	512KB	%AW0~%AW262143	Up to 256K retainable	
	Direct variable	M	256KB	%MW0~%MW131071	Up to 128K retainable
		R	64KB * 2 block	%RW0~%RW32767	64KB per block
		W	128KB	%WW0~%WW65535	Same area as R
	Flag variable	F	4KB	%FW0~%FW2047	System flag
		K	18KB	%KW0~%KW8399	PID RUN area(PID 256 loop)
		L	22KB	%LW0~%LW11263	High speed link flag, P2P flag
		N	42KB	%NW0~%NW25087	P2P Parameter(XG5000 setting)
U		32KB	%UW31.15.31	Analog data refresh area (31 base, 16 slot, 32 channel)	

## A.2 Describes of terms

Before using this product, explain the general terms of Ethernet module. Please refer to the Ethernet technical book for details.

- **Auto-MDIX (Automatic Medium Dependent Interface Crossover)** The type of Ethernet cable is divided into Crossover Cable (TX-RX, RX-TX) and Straight Cable (TX-TX, RX-RX), where the TX / RX is interchanged based on TX / RX. Communication of each network device is possible through connection of TX (node A) -RX (node B) / RX (node A) -TX (node B), so it is impossible to communicate with Straight Cable. However, if there is a function that can electrically exchange TX and RX in the connected node, it is possible to communicate with each other using a straight cable, which is called Auto-MDIX.

- **Auto-Negotiation** Ethernet is the process by which Ethernet devices exchange information about performance, such as operation speed and duplex mode.

- 1) Find out why connection was denied
- 2) Determine the performance of your network equipment
- 3) Change connection speed

- **ARP (Address Resolution Protocol)**

Protocol to search for MAC address by means of correspondent IP address on the Ethernet LAN

- **Bridge**

A device used to connect two networks so to be operated as one network. Bridge is used not only to connect two different types of networks but also to divide one big network into two small networks in order to increase the performance

- **Client**

A user of the network service, or a computer or program (mainly the one requesting services) using other computer's resource.

- **CSMA/CD (Carrier Sense Multiple Access with Collision Detection)**

Each client checks if there is any sign prior to transmission of data to the network (Carrier Sense) and then sends its data when the network is empty. At this time, all the clients have the equal right to send (Multiple Access). If two or more clients send data, collision may occur. The client who detects the collision tries to send again in a specific time.

- **DHCP ( Dynamic Host Configuration Protocol)**

Communication protocol IP standard for automatically allocating and managing setting information necessary for executing TCP / IP communication. Provides uniform management of IP addresses in telecommunication networks in TCP / IP environments.

- **DNS (Domain Name System)**

A method used to convert alphabetic Domain Name on the Internet to its identical Internet number (namely, IP address).

- **Dot Address**

Shows IP address of '100.100.100.100', where each figure is displayed in decimal with 1 byte occupied respectively for 4 bytes in total.

- **Duplex**

It means duplex communication that can send / receive in both directions. Separate the send and receive paths so that they can operate without being affected by each other.

- **EDS File**

Abbreviation for Electronic Data Sheets, a file containing information about the device and its communication settings.

- **E-mail address**

The address of the user with login account for the specific machine connected via the Internet. Usually user's ID @ domain name (machine name) is assigned. In other words, it will be like hjjee@microsoft.com, where @ is called as 'at' displayed with shift+2 pressed on the keyboard. The letters at the back of @ are for the domain name of specific company (school, institute,..) connected with the Internet, and the letters in front of @ are for the user ID registered in the machine. The last letters of the domain name are for the highest level. USA generally uses the following abbreviation as specified below, and Korea uses .kr to stand for Korea. com : usually for companies) / .edu : usually for educational organizations such as universities. / .ac(academy) is mostly used in Korea / .gov : for governmental organizations. For example, nasa.gov is for NASA (government) / .mil : military related sites. For example, af.mil is for USA air force (military)/ .org : private organizations / .au : Australia / .uk : the United Kingdom / .ca : Canada / .kr : Korea / .jp : Japan / .fr : France / .tw : Taiwan, etc.

- **Ethernet**

A representative LAN connection system (IEEE 802.3) developed by Xerox, Intel and DEC of America which can send about 10Mbps and use the packet of 1.5kB. Since Ethernet can allow various types of computers to be connected as one via the network, it has been called a pronoun of LAN as a universal standard with various products available, not limited to some specific companies

- **Explicit Messaging**

In addition to the explicit message and data, this message contains all the information that can be interpreted in the frame.

(XGT EtherNet / IP module provides non-cycle client communication)

- **FDDI (Fiber Distributed Data Interface)**

Based on optical cable, provides 100Mbps, Shared Media Network as Dual Ring method, Token Passing is done in two-way. Max 200Km distance for entire network, Max 2Km between Nodes, Max 500 nodes. Generally, this used as Backbone Network.

- **FTP (File Transfer Protocol)**

An application program used to transfer files between computers among application programs providing TCP/IP protocol. If an account is allowed to the computer to log in, fast log in the computer is available wherever the computer is so to copy files.

- **Gateway**

Software/Hardware used to translate for two different protocols to work together, which is equivalent to the gateway necessary to exchange information with the different system.

- **Header**

It indicates parts of packets, including its own station and the destination station's addresses, and a part for checking for an error.

- **HTML**

Hypertext Markup Language, standard language of WWW. In other words, it is a language system to prepare Hypertext documents. The document made of HTML can be viewed through the web browser

- **HTTP**

Hypertext Transfer Protocol, standard protocol of WWW. It is a protocol supporting the hypermedia system.

- **ICMP (Internet Control Message Protocol)**

An extended protocol of IP address used to create error messages and test packets to control the Internet.

- **Implicit Messaging**

Implicit messages and messages with minimal header information other than data.  
(XGT EtherNet / IP module provides cycle client / cycle server communication)

- **IEEE 802.3**

IEEE 802.3 specifies standards for CSMA/CD based Ethernet Exactly it is a LAN based on CSMA/CD (Carrier Sense Multiple Access with Collision Detection) Ethernet designed by IEEE 802.3 group, which is classified into detailed projects as specified below.

- 1) IEEE P802.3 - 10G Base T study Group

- 2) IEEE P802.3ah - Ethernet in the First Mile Task Force

IEEE P802.3ak - 10G Base-CX4 Task Force. Both IEEE 802.3 and Ethernet are broadband networks using the CSMA / CD scheme and have a common feature that is implemented in the network interface card hardware.

- **IP (Internet Protocol)**

Protocol at the network layer for the Internet

- **IP Address**

Address of respective computers on the Internet made of figures binary of 32 bits (4 bytes) to distinguish the applicable machine on the Internet. Classified into 2 sections, network distinguishing address and host distinguishing address. The network address and the host address is respectively divided into class A, B and C based on the bits allotted. IP address since it shall be unique all over the world, shall be decided not optionally but as assigned by NIC (Network Information Center) of the applicable district when joining the Internet. In Korea, KRNIC (Korea Network Information Center) is in charge of this work. Ex.) 165.244.149.190

- **ISO (International Organization for Standardization)**

A subsidiary organization of UN establishing and managing the international standards.

- **LAN (Local Area Network)**

Called also as local area communication network or district information communication network, which allows lots of computers to exchange data with each other as connected though communication cable within a limited area such as in an office or a building.

- **MAC (Medium Access Control)**

A method used to decide which device should use the network during given time on the broadcast network.

- **Node**

Each computer connected with the network is called Node.

- **Packet**

Package of data which is the basic unit used to send through the network. Usually the package is made of several tens or hundreds of bytes with the header attached in front to which its destination and other necessary information are added.

- **PORT number**

Used to classify the applications on TCP/UDP.

Ex.) 21/tcp : Telet

- **PPP (Point-to-Point Protocol)**

Phone communication protocol which allows packet transmission in connecting with the Internet. In other words, normal phone cable and modem can be used for the computer to connect through TCP/IP with this most general Internet protocol.

Similar to SLIP, however with modern communication protocol factors such as error detection and data compression, it demonstrates more excellent performance than SLIP.

- **Protocol**

Contains regulations related with mutual information transmission method between computers connected with each other through the network. The protocol may specify detailed interface between machines in Low level (for example, which bit/byte should go out through the line) or high level of message exchange regulations as files are transferred through the Internet.

- **Reset**

This is function used when you want to initialize the communication module to clear the error.

Select [Online] [Reset/clear] [PLC reset] in the XG5000 If you execute this function, PLC will restart

- **RPI**

Abbreviation for Requested Packet Interval, which means to send packet.

(XGT EtherNet / IP module is provided in transmission cycle)

- **Router**

A device used to transfer the data packet between the networks. It sends the data packet to its final destination, waits if the network is congested, or decides which LAN is good to connect to at the LAN junction. Namely, it is a special computer/software used to control the two or more networks connected.

- **Server**

The side which passively responds to the client's request and shares its resources.

- **Tag**

Name tag, in other word named variable.

- **TCP (Transmission Control Protocol)**

A transport layer protocol for the Internet

- Data Tx/Rx through connection
- Multiplexing
- Transmission reliable
- Emergent data transmission supported

- **TCP/IP (Transmission Control Protocol/Internet Protocol)**

Transmission protocol used for communication among different kinds of computers, which makes the communication available between general PC and medium host, IBM PC and MAC, and medium or large-sized different types of computer. It is also used as a general term for information transmission protocol between computer networks including FTP, Telnet, SMTP, etc. TCP divides data into packets to send through IP and the packets sent will be united back together through TCP.

- **Telnet**

It means remote login via Internet. To login to remote host via TELNET, account of that host is necessary. But for some hosts providing public service, you can connect without account.

- **Token Ring**

As short-distance network using Token to connect to network having physical ring structure, one of the Node connection methods at network. If node sending data gets Token, then node gets right to send message packet. Realistically structured examples are IEEE 802.5, ProNet-1080 and FDDI. Terms called Token is used as IEEE 802.5

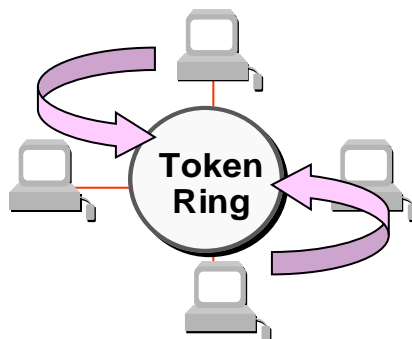

- **UDP (User Datagram Protocol)**

A transport layer protocol for the Internet

- High speed communication because of communication without connection
- Multiplexing
- Lower reliability than TCP in transmission (Tough data doesn't arrive, it doesn't send data again).

- **Watchdog Timer A transport layer protocol for the Internet**

It is a function to set the predetermined execution time of the program and to generate an alarm when the processing is not completed within the specified time, indicating that there is an error in the PLC operation.

- **FDDI (Fiber Distributed Data Interface)**

Based on optical cable, provides 100Mbps, Shared Media Network as Dual Ring method, Token Passing is done in two-way. Max 200Km distance for entire network, Max 2Km between Nodes, Max 500 nodes. Generally, this used as Backbone Network.

- **Ethernet Transceiver**

A device designed to connect a computer or electronic device to a network that enables transmit or receive of messages.

- **Media Converter**

In most cases, it is a device that acts as a transceiver. It is a device that converts the electrical signal used in the UTP network to the light wavelength used in the optical fiber cable.

## A.3 List of flags

### A.3.1 XGK CPU flags

#### A.3.1.1 Special Relay (F) List

Device 1	Device 2	Type	Variable	Function	Description
F0000	-	DWORD	_SYS_STATE	Mode and state	Indicates PLC mode and operation status
-	F00000	BIT	_RUN	RUN	RUN status.
-	F00001	BIT	_STOP	STOP	STOP status.
-	F00002	BIT	_ERROR	ERROR	ERROR status.
-	F00003	BIT	_DEBUG	DEBUG	DEBUG status.
-	F00004	BIT	_LOCAL_CON	Local control	Local control mode.
-	F00005	BIT	_MODBUS_CON	Modbus mode	Modbus control mode.
-	F00006	BIT	_REMOTE_CON	Remote mode	Remote control mode.
-	F00008	BIT	_RUN_EDIT_ST	Edit during RUN	Downloading the editing program during RUN.
-	F00009	BIT	_RUN_EDIT_CHK	Edit during RUN	Internal edit processing during RUN.
-	F0000A	BIT	_RUN_EDIT_DONE	Online editing done	Edit done during RUN.
-	F0000B	BIT	_RUN_EDIT_END	Edit done during RUN	Edit done during RUN.
-	F0000C	BIT	_CMOD_KEY	Operation mode	The operation mode has been changed by key.
-	F0000D	BIT	_CMOD_LPADT	Operation mode	Operation mode changed by local PADT.
-	F0000E	BIT	_CMOD_RPADT	Operation mode	Operation mode changed by remote PADT
-	F0000F	BIT	_CMOD_RLINK	Operation mode	Operation mode changed by remote communication module.
-	F00010	BIT	_FORCE_IN	Forced input	Forced input state.
-	F00011	BIT	_FORCE_OUT	Forced output	Forced output state.
-	F00012	BIT	_SKIP_ON	I/O SKIP	Executing I / O SKIP
-	F00013	BIT	_EMASK_ON	Error mask	Executing Error mask
-	F00014	BIT	_MON_ON	Monitor	Executing monitor
-	F00015	BIT	_USTOP_ON	STOP	Stopped by STOP function.
-	F00016	BIT	_ESTOP_ON	ESTOP	Stopped by ESTOP function.
-	F00017	BIT	_CONPILE_MODE	Compiling	Compiling is in progress.
-	F00018	BIT	_INIT_RUN	Initializing	Initialization task is running.
-	F0001C	BIT	_PB1	Program code 1	Program code 1 is selected.
-	F0001D	BIT	_PB2	Program code 2	Program code 2 is selected.
-	F0001E	BIT	_CB1	Compile code 1	Compilation code 1 is selected.
-	F0001F	BIT	_CB2	Compile code 2	Compilation code 2 is selected.

Device 1	Device 2	Type	Variable	Function	Description
F0002	-	DWORD	_CNF_ER	System error	Indicates the critical error state of the system.
-	F00020	BIT	_CPU_ER	CPU error	There is an error in the CPU configuration.
-	F00021	BIT	_IO_TYER	Module type error	The module type does not match.
-	F00022	BIT	_IO_DEER	Module detachment error	The module has been detached
-	F00023	BIT	_FUSE_ER	Blown fuse error	The fuse has blown.
-	F00024	BIT	_IO_RWER	Module I/O error	A problem occurred in the module I/O.
-	F00025	BIT	_IP_IFER	Module interface error	There was a problem with the special / communication module interface.
-	F00026	BIT	_ANNUM_ER	External device fault	A fault has been detected in the external device.
-	F00028	BIT	_BPRM_ER	Basic Parameter	It is abnormal to the basic parameter.
-	F00029	BIT	_IOPRM_ER	IO parameter	There is a I/O configuration parameter error.
-	F0002A	BIT	_SPPRM_ER	Special module parameter	The special module parameter is abnormal.
-	F0002B	BIT	_CPPRM_ER	Communication module parameter	The communication module parameter is abnormal.
-	F0002C	BIT	_PGM_ER	Program error	There is an error in the program.
-	F0002D	BIT	_CODE_ER	Code error	There is an error in the program code.
-	F0002E	BIT	_SWDT_ER	System watchdog	System watchdog worked.
-	F0002F	BIT	_BASE_POWER_ER	Power error	The base power supply is abnormal.
-	F00030	BIT	_WDT_ER	Scan watchdog	The scan watchdog worked.
F0004	-	DWORD	_CNF_WAR	System warning	Reports the minor error status of the system.
-	F00040	BIT	_RTC_ER	RTC error	There is abnormality in the module.
-	F00041	BIT	_DBCK_ER	Backup error	There was a problem with the data backup.
-	F00042	BIT	_HBCK_ER	Restart error	Hot restart is unavailable.
-	F00043	BIT	_ABSD_ER	Abnormal operation stop	Stop by abnormal operation.
-	F00044	BIT	_TASK_ER	Task collision	It is collided to the task.
-	F00045	BIT	_BAT_ER	Battery error	Battery condition is abnormal.
-	F00046	BIT	_ANNUM_WAR	External device fault	A minor error in external device has been detected
-	F00047	BIT	_LOG_FULL	Memory full	Log memory is full.
-	F00048	BIT	_HS_WAR1	High speed link 1	High speed link - parameter 1 or more
-	F00049	BIT	_HS_WAR2	High speed link 2	High speed link- parameter 2 or more
-	F0004A	BIT	_HS_WAR3	High speed link 3	High speed link- parameter 3 or more
-	F0004B	BIT	_HS_WAR4	High speed link 4	High speed link- parameter 4 or more

## Appendix

Device 1	Device 2	Type	Variable	Function	Description
-	F0004C	BIT	_HS_WAR5	High speed link 5	High speed link- parameter 5 or more
-	F0004D	BIT	_HS_WAR6	High speed link 6	High speed link- parameter 6 or more
-	F0004E	BIT	_HS_WAR7	High speed link 7	High speed link- parameter 7 or more
-	F0004F	BIT	_HS_WAR8	High speed link 8	High speed link- parameter 8 or more
-	F00050	BIT	_HS_WAR9	High speed link 9	High speed link- parameter 9 or more
-	F00051	BIT	_HS_WAR10	High speed link 10	High speed link - parameter 10 or more
-	F00052	BIT	_HS_WAR11	High speed link 11	High speed link - parameter 11 or more
-	F00053	BIT	_HS_WAR12	High speed link 12	High speed link - parameter 12 or more
-	F00054	BIT	_P2P_WAR1	P2P parameter 1	P2P - parameter 1 error
-	F00055	BIT	_P2P_WAR2	P2P parameter 2	P2P- parameter 2 error
-	F00056	BIT	_P2P_WAR3	P2P parameter 3	P2P- parameter 3 error
-	F00057	BIT	_P2P_WAR4	P2P parameter 4	P2P- parameter 4 error
-	F00058	BIT	_P2P_WAR5	P2P parameter 5	P2P- parameter 5 error
-	F00059	BIT	_P2P_WAR6	P2P parameter 6	P2P- parameter 6 error
-	F0005A	BIT	_P2P_WAR7	P2P parameter 7	P2P- parameter 7 error
-	F0005B	BIT	_P2P_WAR8	P2P parameter 8	P2P- parameter 8 error
-	F0005C	BIT	_CONSTANT_ER	Fixed period error	Fixed period error
F0009	-	WORD	_USER_F	User contact point	Timer that can be used by the user
-	F00090	BIT	_T20MS	20ms	Clock of 20ms cycle.
-	F00091	BIT	_T100MS	100ms	Clock of 100ms cycle.
-	F00092	BIT	_T200MS	200ms	Clock of 200ms cycle.
-	F00093	BIT	_T1S	1s	Clock of 1s cycle.
-	F00094	BIT	_T2S	2s	Clock of 2s cycle.
-	F00095	BIT	_T10S	10s	Clock of 10s cycle.
-	F00096	BIT	_T20S	20s	Clock of 20s cycle.
-	F00097	BIT	_T60S	60s	Clock of 60s cycle.
-	F00099	BIT	_ON	Always On	This bit is always On.
-	F0009A	BIT	_OFF	Always Off	This bit is always Off.
-	F0009B	BIT	_1ON	1scan On	Only the first scan is On.
-	F0009C	BIT	_1OFF	1scan Off	Only the first scan is Off.
-	F0009D	BIT	_STOG	Reversal	Reverses every scan
F0010	-	WORD	_USER_CLK	User CLOCK	User-settable CLOCK.
-	F00100	BIT	_USR_CLK0	Repeat scan specified	Specified scan On/Off Clock 0
-	F00101	BIT	_USR_CLK1	Repeat scan specified	Specified scan On/Off Clock 1

Device 1	Device 2	Type	Variable	Function	Description
-	F00102	BIT	_USR_CLK2	Repeat scan specified	Specified scan On/Off Clock 2
-	F00103	BIT	_USR_CLK3	Repeat scan specified	Specified scan On/Off Clock 3
-	F00104	BIT	_USR_CLK4	Repeat scan specified	Specified scan On/Off Clock 4
-	F00105	BIT	_USR_CLK5	Repeat scan specified	Specified scan On/Off Clock 5
-	F00106	BIT	_USR_CLK6	Repeat scan specified	Specified scan On/Off Clock 6
-	F00107	BIT	_USR_CLK7	Repeat scan specified	Specified scan On/Off Clock 7
F0011	-	WORD	_LOGIC_RESULT	Logic result	Indicates the logical result
-	F00110	BIT	_LER	Operation error	ON for 1 scan on operation error
-	F00111	BIT	_ZERO	Zero flag	ON when the operation result is 0
-	F00112	BIT	_CARRY	Carry flag	ON when carry occurs during operation
-	F00113	BIT	_ALL_OFF	All output OFF	ON when all outputs are OFF
-	F00115	BIT	_LER_LATCH	Operation error latch	Continue On when operation error occurs
F0012	-	WORD	_CMP_RESULT	Comparison result	Indicates the comparison result.
-	F00120	BIT	_LT	LT flag	If “less than” to On
-	F00121	BIT	_LTE	LTE flag	If “less than or equal” to On
-	F00122	BIT	_EQU	EQU flag	If “equal” to On
-	F00123	BIT	_GT	GT flag	If “larger than” to On
-	F00124	BIT	_GTE	GTE flag	If “larger than or equal” to On
-	F00125	BIT	_NEQ	NEQ flag	If it is “not equal” to On
F0013	-	WORD	_AC_F_CNT	Instantaneous interruption	Indicates the number of instantaneous interruption occurrences.
F0014	-	WORD	_FALS_NUM	FALS No.	Displays the number of FALS.
F0015	-	WORD	_PUTGET_ERR0	PUT/GET error 0	Main base PUT / GET error
F0016	-	WORD	_PUTGET_ERR1	PUT/GET error 1	Extension base 1-stage PUT/GET error
F0017	-	WORD	_PUTGET_ERR2	PUT/GET error 2	Extension base 2-stage PUT/GET error
F0018	-	WORD	_PUTGET_ERR3	PUT/GET error 3	Extension base 3-stage PUT/GET error
F0019	-	WORD	_PUTGET_ERR4	PUT/GET error 4	Extension base 4-stage PUT/GET error
F0020	-	WORD	_PUTGET_ERR5	PUT/GET error 5	Extension base 5-stage PUT/GET error
F0021	-	WORD	_PUTGET_ERR6	PUT/GET error 6	Extension base 6-stage PUT/GET error
F0022	-	WORD	_PUTGET_ERR7	PUT/GET error 7	Extension base 7-stage PUT/GET error
F0023	-	WORD	_PUTGET_NDR0	PUT/GET complete 0	Main Base PUT / GET Complete
F0024	-	WORD	_PUTGET_NDR1	PUT/GET complete 1	PUT/GET done in the extended base level 1
F0025	-	WORD	_PUTGET_NDR2	PUT/GET complete 2	PUT/GET done in the extended base level 2
F0026	-	WORD	_PUTGET_NDR3	PUT/GET complete 3	PUT/GET done in the extended base level 3
F0027	-	WORD	_PUTGET_NDR4	PUT/GET complete 4	PUT/GET done in the extended base level 4
F0028	-	WORD	_PUTGET_NDR5	PUT/GET complete 5	PUT/GET done in the extended base level 5

## Appendix

Device 1	Device 2	Type	Variable	Function	Description
F0029	-	WORD	_PUTGET_NDR6	PUT/GET complete 6	PUT/GET done in the extended base level 6
F0030	-	WORD	_PUTGET_NDR7	PUT/GET complete 7	PUT/GET done in the extended base level 7
F0044	-	WORD	_CPU_TYPE	CPU type	Indicates information related to the CPU type.
F0045	-	WORD	_CPU_VER	CPU Version	Indicates CPU version.
F0046	-	DWORD	_OS_VER	OS Version	Indicates OS version.
F0048	-	DWORD	_OS_DATE	OS date	Indicates the OS distribution date.
F0050	-	WORD	_SCAN_MAX	Maximum scan time	Indicates maximum scan time.
F0051	-	WORD	_SCAN_MIN	Minimum scan time	Indicates minimum scan time.
F0052	-	WORD	_SCAN_CUR	Current scan time	Indicates current scan time.
F0053	-	WORD	_MON_YEAR	Month / Year	Indicates month and year data of PLC.
F0054	-	WORD	_TIME_DAY	Time / Day	Indicates time and day data of PLC.
F0055	-	WORD	_SEC_MIN	Second / Minute	Indicates second and minute data of PLC.
F0056	-	WORD	_HUND_WK	Hundred years / Weekday	Indicates hundred years and weekday data of PLC.
F0057	-	WORD	_FPU_INFO	FPU calculation result	Displays floating-point results.
-	F00570	BIT	_FPU_LFLAG_I	Incorrect error latch	Latch on Inaccurate Error
-	F00571	BIT	_FPU_LFLAG_U	Underflow latch	Latches the error when underflow occurs.
-	F00572	BIT	_FPU_LFLAG_O	Overflow latch	Latches the error when overflow occurs.
-	F00573	BIT	_FPU_LFLAG_Z	Zero divide latch	Latches the error when zero divide occurs.
-	F00574	BIT	_FPU_LFLAG_V	Invalid operation latch	Latch when invalid operation.
-	F0057A	BIT	_FPU_FLAG_I	Inaccurate error	Indicates an inaccuracy error occurred.
-	F0057B	BIT	_FPU_FLAG_U	Underflow	Display the error when underflow occurs.
-	F0057C	BIT	_FPU_FLAG_O	Overflow	Display the error when overflow occurs.
-	F0057D	BIT	_FPU_FLAG_Z	Zero divide	Displays at zero division
-	F0057E	BIT	_FPU_FLAG_V	Invalid operation	Display when invalid operation.
-	F0057F	BIT	_FPU_FLAG_E	Input of irregular value	Reports when input of irregular value.
F0058	-	DWORD	_ERR_STEP	Error step	Saves error step.
F0060	-	DWORD	_REF_COUNT	Refresh	Increase when module Refresh.
F0062	-	DWORD	_REF_OK_CNT	Refresh OK	Increase when module Refresh is normal.
F0064	-	DWORD	_REF_NG_CNT	Refresh NG	Increase when module refresh is abnormal
F0066	-	DWORD	_REF_LIM_CNT	Refresh LIMIT	Increase when module refresh is abnormal (TIME OUT)
F0068	-	DWORD	_REF_ERR_CNT	Refresh ERROR	Increase when module refresh is abnormal
F0070	-	DWORD	_MOD_RD_ERR_CNT	Module ERROR READ	It increases when the module 1 word is read abnormally.
F0072	-	DWORD	_MOD_WR_ERR_CNT	Module ERROR WRITE	It increases when the module 1 word is write abnormally.

Device 1	Device 2	Type	Variable	Function	Description
F0074	-	DWORD	_CA_CNT	Block service	Increase in module's block data service
F0076	-	DWORD	_CA_LIM_CNT	Block service LIMIT	Increase in block data abnormal service
F0078	-	DWORD	_CA_ERR_CNT	Block service ERROR	Increase in block data abnormal service
F0080	-	DWORD	_BUF_FULL_CNT	Buffer Full	Increase when CPU internal buffer is full.
F0082	-	DWORD	_PUT_CNT	PUT count	It increases when performing PUT.
F0084	-	DWORD	_GET_CNT	GET count	It increases when performing GET.
F0086	-	DWORD	_KEY	Current key	Indicates the current state of the local key.
F0088	-	DWORD	_KEY_PREV	Previous key	Indicates the previous state of the local key.
F0090	-	WORD	_IO_TYER_N	Mismatch slot	Module type mismatch slot number display
F0091	-	WORD	_IO_DEER_N	Detached slot	Display the slot number where the module has been detached
F0092	-	WORD	_FUSE_ER_N	Fuse disconnection slot	Indicates the slot number where the fuse blows
F0093	-	WORD	_IO_RWER_N	RW error slot	Module read / write error slot number display
F0094	-	WORD	_IP_IFER_N	IF error slot	Module interface error slot number display
F0096	-	WORD	_IO_TYER0	Module type 0 error	Main base module type error.
F0097	-	WORD	_IO_TYER1	Module type 1 error	Extension base 1-stage module type error
F0098	-	WORD	_IO_TYER2	Module type 2 error	Extension base 2-stage module type error
F0099	-	WORD	_IO_TYER3	Module type 3 error	Extension base 3-stage module type error
F0100	-	WORD	_IO_TYER4	Module type 4 error	Extension base 4-stage module type error
F0101	-	WORD	_IO_TYER5	Module type 5 error	Extension base 5-stage module type error
F0102	-	WORD	_IO_TYER6	Module type 6 error	Extension base 6-stage module type error
F0103	-	WORD	_IO_TYER7	Module type 7 error	Extension base 7-stage module type error
F0104	-	WORD	_IO_DEER0	Module detachment 0 error	Main base module Detach error.
F0105	-	WORD	_IO_DEER1	Module detachment 1 error	Extension base 1-stage module detach error.
F0106	-	WORD	_IO_DEER2	Module detachment 2 error	Extension base 2-stage module detach error.
F0107	-	WORD	_IO_DEER3	Module detachment 3 error	Extension base 3-stage module detach error.
F0108	-	WORD	_IO_DEER4	Module detachment 4 error	Extension base 4-stage module detach error.
F0109	-	WORD	_IO_DEER5	Module detachment 5 error	Extension base 5-stage module detach error.
F0110	-	WORD	_IO_DEER6	Module detachment 6 error	Extension base 6-stage module detach error.
F0111	-	WORD	_IO_DEER7	Module detachment 7 error	Extension base 7-stage module detach error.
F0112	-	WORD	_FUSE_ER0	Fuse disconnection 0 error	Main base fuse disconnection error
F0113	-	WORD	_FUSE_ER1	Fuse disconnection 1 error	Extension base 1-stage fuse disconnection error
F0114	-	WORD	_FUSE_ER2	Fuse disconnection 2 error	Extension base 2-stage fuse disconnection error
F0115	-	WORD	_FUSE_ER3	Fuse disconnection 3 error	Extension base 3-stage fuse disconnection error

## Appendix

Device 1	Device 2	Type	Variable	Function	Description
F0116	-	WORD	_FUSE_ER4	Fuse disconnection 4 error	Extension base 4-stage fuse disconnection error
F0117	-	WORD	_FUSE_ER5	Fuse disconnection 5 error	Extension base 5-stage fuse disconnection error
F0118	-	WORD	_FUSE_ER6	Fuse disconnection 6 error	Extension base 6-stage fuse disconnection error
F0119	-	WORD	_FUSE_ER7	Fuse disconnection 7 error	Extension base 7-stage fuse disconnection error
F0120	-	WORD	_IO_RWER0	Module RW 0 error	Main base module read / write error
F0121	-	WORD	_IO_RWER1	Module RW 1 error	Expansion base 1-stage module read / write error
F0122	-	WORD	_IO_RWER2	Module RW 2 error	Expansion base 2 stage module read / write error.
F0123	-	WORD	_IO_RWER3	Module RW 3 error	Expansion base 3 stage module read / write error.
F0124	-	WORD	_IO_RWER4	Module RW 4 error	Expansion base 4 stage module read / write error.
F0125	-	WORD	_IO_RWER5	Module RW 5 error	Expansion base 5 stage module read / write error.
F0126	-	WORD	_IO_RWER6	Module RW 6 error	Expansion base 6 stage module read / write error.
F0127	-	WORD	_IO_RWER7	Module RW 7 error	Expansion base 7 stage module read / write error.
F0128	-	WORD	_IO_IFER_0	Module IF 0 error	Main base module interface error.
F0129	-	WORD	_IO_IFER_1	Module IF 1 error	Extension base 1-stage module interface error.
F0130	-	WORD	_IO_IFER_2	Module IF 2 error	Extension base 2-stage module interface error.
F0131	-	WORD	_IO_IFER_3	Module IF 3 error	Extension base 3-stage module interface error.
F0132	-	WORD	_IO_IFER_4	Module IF 4 error	Extension base 4-stage module interface error.
F0133	-	WORD	_IO_IFER_5	Module IF 5 error	Extension base 5-stage module interface error.
F0134	-	WORD	_IO_IFER_6	Module IF 6 error	Extension base 6-stage module interface error.
F0135	-	WORD	_IO_IFER_7	Module IF 7 error	Extension base 7-stage module interface error.
F0136	-	WORD	_RTC_DATE	RTC date	Displays the current date .
F0137	-	WORD	_RTC_WEEK	RTC weekday	Displays the current day of week
F0138	-	DWORD	_RTC_TOD	RTC time	Current time in RTC (ms unit)
F0140	-	DWORD	_AC_FAIL_CNT	Save the number of power off.	Saves the number of times the power cutoff.
F0142	-	DWORD	_ERR_HIS_CNT	Save the number of error count.	Saves the number of times an error occurred.
F0144	-	DWORD	_MOD_HIS_CNT	Save the number of mode change.	Saves the number of times the mode change.
F0146	-	DWORD	_SYS_HIS_CNT	History occurrence count	Saves the number of system history occurrences.
F0148	-	DWORD	_LOG_ROTATE	Log rotate	Saves log locate information.
F0150	-	WORD	_BASE_INFO0	Slot information 0	Main base slot information
F0151	-	WORD	_BASE_INFO1	Slot information 1	Extension base 1-slot information
F0152	-	WORD	_BASE_INFO2	Slot information 2	Extension base 2-slot information
F0153	-	WORD	_BASE_INFO3	Slot information 3	Extension base 3-slot information

Device 1	Device 2	Type	Variable	Function	Description
F0154	-	WORD	_BASE_INFO4	Slot information 4	Extension base 4-slot information
F0155	-	WORD	_BASE_INFO5	Slot information 5	Extension base 5-slot information
F0156	-	WORD	_BASE_INFO6	Slot information 6	Extension base 6-slot information
F0157	-	WORD	_BASE_INFO7	Slot information 7	Extension base 7-slot information
F0158	-	WORD	_RBANK_NUM	Block number in use	Block number which is currently being used
F0159	-	WORD	_RBLOCK_STATE	Flash state	Flash block state
F0160	-	DWORD	_RBLOCK_RD_FLAG	Flash read	ON when reading data of flash N block
F0162	-	DWORD	_RBLOCK_WR_FLAG	Write on flash	On when writing flash N block data
F0164	-	DWORD	_RBLOCK_ER_FLAG	Flash error	An error occurred during flash N block service.
F1024	-	WORD	_USER_WRITE_F	Available contact point	Contact point available in program.
-	F10240	BIT	_RTC_WR	RTC RW	Writing and reading data in RTC
-	F10241	BIT	_SCAN_WR	Scan WR	Initializing the value of scan.
-	F10242	BIT	_CHK_ANC_ERR	External critical error request	Request of fatal error detection from external device
-	F10243	BIT	_CHK_ANC_WAR	External light error request	Request of minor error detection from external device
F1025	-	WORD	_USER_STAUS_F	User contact point	User contact point
-	F10250	BIT	_INIT_DONE	Initialization completed	Indicates completion of initialization task
F1026	-	WORD	_ANC_ERR	External critical error information	Displays fatal error information of external devices
F1027	-	WORD	_ANC_WAR	External light error warning	Displays minor error information of external devices
F1034	-	WORD	_MON_YEAR_DT	Month / Year	Clock information data (month / year)
F1035	-	WORD	_TIME_DAY_DT	Time / Day	Clock information data (hour/day)
F1036	-	WORD	_SEC_MIN_DT	Second / Minute	Clock information data (second/minute)
F1037	-	WORD	_HUND_WK_DT	Hundred years / Weekday	Clock information data (hundred year/week)

### A.3.2 XGI CPU flags

#### A.3.2.1 Mode and state

Flag Name	TYPE	Memory	Content	Description
_SYS_STATE	DWORD	%FD0	PLC mode and states	Displays the operation mode and operation status of the system.
_RUN	BOOL	%FX0	RUN	Indicates operation state of PLC module.
_STOP	BOOL	%FX1	STOP	
_ERROR	BOOL	%FX2	ERROR	
_DEBUG	BOOL	%FX3	DEBUG	
_LOCAL_CON	BOOL	%FX4	Local control	It displays the status that can change the operation mode only by mode key or GMWIN.
_BASE_EMASK_INFO	DWORD	%FD477	Base fault mask information	Displays base fault mask information.
_REMOTE_CON	BOOL	%FX6	Remote mode on	Remote control mode.
_RUN_EDIT_ST	BOOL	%FX8	Edit during running	Downloading the program during edit during running.
_RUN_EDIT_CHK	BOOL	%FX9		Internal processing during edit during running..
_RUN_EDIT_DONE	BOOL	%FX10		Edit during running completed.
_RUN_EDIT_NG	BOOL	%FX11		Abnormal completion during edit during running.
_CMOD_KEY	BOOL	%FX12	Operation mode change	Operation mode change by key
_CMOD_LPADT	BOOL	%FX13		Operation mode change by local PADT
_CMOD_RPADT	BOOL	%FX14		Operation mode change by remote PADT
_CMOD_RLINK	BOOL	%FX15		Operation mode change by remote communication module
_FORCE_IN	BOOL	%FX16	Forced input	Indicates that forced On/Off for input contact is in progress.
_FORCE_OUT	BOOL	%FX17	Forced output	Indicates that forced On/Off for output contact is in progress.
_SKIP_ON	BOOL	%FX18	I/O SKIP	Executing I / O SKIP
_EMASK_ON	BOOL	%FX19	Error mask	Executing Error mask
_MON_ON	BOOL	%FX20	Executing monitor	Executing monitor
_USTOP_ON	BOOL	%FX21	Stopped by STOP function.	Stop after scan completion by STOP function during RUN mode.
_ESTOP_ON	BOOL	%FX22	Stopped by ESTOP function.	Immediate stop by ESTOP function during RUN mode operation
_INIT_RUN	BOOL	%FX24	Performing initialization task.	Indicates during executing initial program which is programmed by user.
_PB1	BOOL	%FX28	Program code 1	Program code 1 is selected.
_PB2	BOOL	%FX29	Program code 2	Program code 2 is selected.
_BASE_INFO	ARRAY	%FW150	Base information	Display the base information.
_RTC_WR	BOOL	%FX16384	Data write and read in RTC.	Data write and read in RTC.
_SCAN_WR	BOOL	%FX16385	Initializing the value of scan.	Initializing the value of scan.
_CHK_ANC_ERR	BOOL	%FX16386	External critical error request	Request of fatal error detection from external device
_CHK_ANC_WARN	BOOL	%FX16387	External light error request	Request of minor error detection from external device

Flag Name	TYPE	Memory	Content	Description
_BASE_SKIP_IN FO	DWORD	%FD478	Base Skip information	Display the base skip information.
_INIT_DONE	BOOL	%FX16400	Initialization task completion.	If this flag is set by user's initial program, it is started to execution of scan program after initial program completion.
_KEY	DWORD	%FD43	Current key	Indicates the current state of the local key.
_FUSE_ER_PMT	BOOL	%FX15232	Setting continue running when a fuse error occurs.	Setting continue running when a fuse error occurs.
_CP_ER_PMT	BOOL	%FX15235	Setting continue running when communication module error occurs.	Setting continue running when communication module error occurs.
_IO_ER_PMT	BOOL	%FX15233	Setting continue running when IO module error occurs.	Setting continue running when IO module error occurs.
_SP_ER_PMT	BOOL	%FX15234	Setting continue running when special module error occurs.	Display setting continue running when special module error occurs.
_INIT_RUN	BOOL	%FX24	Executing the initial task	Display executing the initial task.

### A3.2.2 System error

Flag Name	TYPE	Memory	Content	Description
_CNF_ER	DWORD	%FD1	System errors(critical error)	Handles error flags about non-operation fault error as below.
_IO_TYER	BOOL	%FX33	Module type mismatch error	Representative flag displayed when I/O configuration parameter for each slot is not matched with practical module configuration or a specific module is applied in the wrong location. (Refer to _IO_TYER_N, _IO_TYER[n])
_IO_DEER	BOOL	%FX34	Module detachment error	Representative flag displayed when the module configuration for each slot is changed while running.(Refer to _IO_DEER_N, _IO_DEER[n])
_FUSE_ER	BOOL	%FX35	Fuse cutoff error	Representative flag displayed when the fuse of module is cut off.(Refer to _FUSE_ER_N, _FUSE_ER[n])
_IO_TYER_N	WORD	%FW90	Slot number of mismatched module type	When I/O configuration parameter for each slot is not matched with practical module configuration or a specific module is applied in the wrong position, displayed as the lowest slot number after detecting these mismatch error in slot locations.
_IO_DEER_N	WORD	%FW91	Module detached slot no.	When slot module configuration is changed while PLC running, displayed as the lowest slot number after detecting these detachment error in slot locations.
_FUSE_ER_N	WORD	%FW92	Slot number of fuse cut off	When a fuse equipped module is cut off, displayed as the lowest slot number after detecting this error in slot locations.
_ANNUM_ER	BOOL	%FX38	Critical fault detection error in external device	Representative flag displayed when critical fault error detected by user program is recorded in _ANC_ERR[n].
_BPRM_ER	BOOL	%FX40	Basic Parameter	It is abnormal to the basic parameter.
_IOPRM_ER	BOOL	%FX41	IO parameter	It is abnormal to the IO configuration parameter.
_SPPRM_ER	BOOL	%FX42	Special module parameter error	It is abnormal to the special module parameter.
_CPPRM_ER	BOOL	%FX43	Communication module parameter error	It is abnormal to the communication module parameter.
_PGM_ER	BOOL	%FX44	Program error	Indicates that there is problem with user-made program checksum.
_FUSE_ERR	WORD	%FW112	Fuse cutoff error	Display fuse cutoff error.
_CODE_ER	BOOL	FX45	Program Code error	Indicates that while user program is running, the program code can't be interpreted.

Flag Name	TYPE	Memory	Content	Description
_SWDT_ER	BOOL	%FX46	CPU abnormal ends.	Displayed when the saved program gets damages by an abnormal end of CPU or program cannot work.
_BASE_POWER_ER	BOOL	%FX47	Power error	The base power supply is abnormal.
_WDT_ER	BOOL	%FX48	Scan watchdog error	Indicates that the program scan time exceeds the scan watchdog time specified by a parameter.
_IO_DEERR	WORD	FW104	Module detachment error	Display module detachment error.
_IO_TYERR	WORD	%FW96	Module type mismatch error	Display module type mismatch error.

### A.3.2.3 System Warning

Flag Name	TYPE	Memory	Content	Description
_CNF_WAR	DWORD	%FD2	System warning	Representative flag displayed the system warning state.
_RTC_ER	BOOL	%FX64	RTC error	Indicates that RTC data is abnormal
_P2P_WAR	BOOL	%FX84	P2P parameter error - representative flag	Display P2P parameter error - representative flag
_EIP_TAG_WAR	BOOL	%FX95	EtherNet/IP TAG information error	Display EtherNet/IP TAG information error.
_HS_WAR	BOOL	%FX72	High-speed Link parameter error - representative flag	Display High-speed Link parameter error - representative flag
_HS_WAR_W	WORD	%FW58	High-speed Link parameter error - whole information	Display High-speed Link parameter error - whole information
_AB_SD_ER	BOOL	%FX67	Abnormal operation stop	Stop by abnormal operation.
_TASK_ER	BOOL	%FX68	Task collision	It is collided to the task.
_BAT_ER	BOOL	%FX69	Battery error	Battery condition is abnormal.
_ANNUM_WAR	BOOL	%FX70	External device fault	Indicates that the minor fault in the external device is detected.
_P2P_WAR_W	WORD	%FW59	P2P parameter error - whole information	Display P2P parameter error - whole information
_BASE_INFO_ER	BOOL	%FX49	Base information error	It is occurred to abnormality in the main base information.
_HS_WARn	BOOL	%FX928	High speed link- Parameter	It is abnormal to the high speed link parameter n.(n: 1~12)
_P2P_WARn	BOOL	%FX944	P2P - parameter	It is abnormal to the P2P parameter n. (n: 1~8)
_CONSTANT_ER	BOOL	%FX92	Fixed period error	Fixed period error
_ANC_ERR	WORD	%FW1026	Critical fault information of external device	Critical fault of external device is detected by user program, and that error is saved at this zone as numbers which can identify 16 error types.
_ANC_WAR	WORD	%FW1027	Minor error information in external device	Minor fault in external device is detected by user program, and the bit position of the occurred error is displayed as an integer in occurrence order.
_SLOT_EMASK_INFO	WORD	%FW958	Slot Fault Mask information	Display slot fault mask information.
_SLOT_SKIP_INFO	WORD	%FW966	Slot Skip information	Display slot Skip information.

### A.3.2.4 User flag

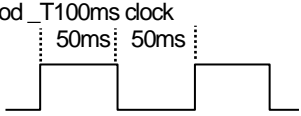
Flag Name	TYPE	Memory	Content	Description
_T20MS	BOOL	%FX144	20ms cycle clock	Clock signal used in user program reverses On/Off per a half cycle Reversal of signal is processed after the scan is completed, so the clock signal may be delayed or distorted according to the program execution time. Please use more enough long clock signal than PLC scan time. The clock signal begins from the Off state at the beginning of the initialization program and scan program.  Example of _T100ms clock 
_T100MS	BOOL	%FX145	100ms cycle clock	
_T200MS	BOOL	%FX146	200ms cycle clock	
_T1S	BOOL	%FX147	1s cycle clock	
_T2S	BOOL	%FX148	2s cycle clock	
_T10S	BOOL	%FX149	10s cycle clock	
_T20S	BOOL	%FX150	20s cycle clock	
_T60S	BOOL	%FX151	60s cycle clock	
_ON	BOOL	%FX153	Ordinary time On	Always On state flag, used when writing user program.
_OFF	BOOL	%FX154	Ordinary time Off	Always Off state flag, used when writing user program.
_1ON	BOOL	%FX155	1'st scan On	Only 1'st scan On after operation start
_1OFF	BOOL	%FX156	1'st scan Off	Only 1'st scan Off after operation start
_STOG	BOOL	%FX157	Scan toggle	On/Off toggle flag per every scan when user program is working. (On state for first scan)

### A.3.2.5 Operation result flag

Flag Name	TYPE	Memory	Content	Description
_ERR	BOOL	%FX176	Operation error flag	Operation error flag on the basis of operation function (FN) or function block (FB), is renewed every time operation works.
_LER	BOOL	%FX181	Operation error latch flag	Operation error latch flag on the basis of program block (PB), the error indication which occurs while program block running keeps until the program ends. It is available to delete by a program.
_ARY_IDX_ERR	BOOL	%FX28864	Error flag of array index range over	Error flag displayed when exceeding the setting array numbers.
_ARY_IDX_LER	BOOL	%FX28896	Latch error flag of array index range over	Latch error flag displayed when exceeding the setting array numbers.
_ALL_OFF	BOOL	%FX179	All output Off	On when all outputs are Off

### A.3.2.6 System operation status information

Flag Name	TYPE	Memory	Content	Description
_CPU_TYPE	WORD	%FW44	Indicates CPU Type Information.	Displays the operation mode and operation status information
_CPU_VER	WORD	%FW45	CPU version.	Display CPU version number.
_OS_VER	DWORD	%FD23	OS version.	Display System OS version number.
_OS_VER_PATCH	DWORD	%FD89	OS patch version	Displays OS version to two decimal places.
_OS_DATE	DWORD	%FD24	OS date	Display OS date.
_SCAN_MAX	WORD	%FW50	Maximum scan time	Indicates max. scan time during operation. Unit:0.1ms

## Appendix

Flag Name	TYPE	Memory	Content	Description
_SCAN_MIN	WORD	%FW51	Minimum scan time	Indicates min. scan time during operation. Unit:0.1ms
_SCAN_CUR	WORD	%FW52	Current scan time	Indicates current scan time during operation. Unit:0.1ms
_RTC_TIME[0]	BYTE	%FB106	RTC TIME[Year]	Indicates PLC Clock data(Year).
_RTC_TIME[1]	BYTE	%FB107	RTC TIME[Month]	Indicates PLC Clock data(Month).
_RTC_TIME[2]	BYTE	%FB108	RTC TIME[Date]	Indicates PLC Clock data(Date).
_RTC_TIME[3]	BYTE	%FB109	RTC TIME[Time]	Indicates PLC Clock data(Hour).
_RTC_TIME[4]	BYTE	%FB110	RTC TIME[Minute]	Indicates PLC Clock data(Minute).
_RTC_TIME[5]	BYTE	%FB111	RTC TIME[Second]	Indicates PLC Clock data(Second).
_RTC_TIME[6]	BYTE	%FB112	RTC TIME[Day]	Indicates PLC Clock data(Day).
_RTC_TIME[7]	BYTE	%FB113	RTC TIME[Hundred year]	Indicates PLC Clock data(Hundred year).
_RTC_DATE	WORD	%FW136	Current date of RTC	Indicated on the basis of 1.Jan.1984.
_RTC_WEEK	WORD	%FW137	Current a day of the week of RTC	Indicates a day of the week.(0:Mon, 1:Tue, 2:Wed, 3:Thu, 4:Fri, 5:Sat, 6:Sun)
_RTC_TOD	DWORD	%FD69	Current time in RTC (ms unit)	Indicates a data for the time of the day on the basis of 00:00:00 (unit : ms).
_RBANK_NUM	WORD	%FW158	Block number which is currently being used	Display block number which is currently being used
_AC_F_CNT	UINT	%FW13	Calculation of momentarily shut-down count	Report of momentarily shut-down count during RUN mode operation.
_FALS_NUM	WORD	%FW14	FALS number	Displays the number of FALS.
_SOE_LOG_CNT	WORD	%FW1786	SOE event occurrence count	Increase SOE event count.
_SOE_LOG_ROTATE	WORD	%FW1787	SOE event rotate information	Increases when 3000 events are exceeded
_SOE_READ_LOG_CNT	WORD	%FW1784	SOE events count read by the user	Increase SOE event count read by using SOE_RD function block.
_SOE_READ_LOG_ROTATE	WORD	FW1785	SOE event rotate information read by the user	Increase when SOE event count read by using SOE_RD function block reaches 3000.
_HS_ENABLE_STATE	ARRAY	%FX15840	HS enable/disable current status	Display HS enable/disable current status.
_HS_REQ	ARRAY	%FX16480	HS enable/disable request	Changes the state of high speed link enable/disable.
_HS_REQ_NUM	ARRAY	%FX16496	Setting enable/disable for high speed link	Display setting enable/disable for high speed link
_P2P_ENABLE_STATE	ARRAY	%FX15872	P2P enable/disable current status	Display P2P enable/disable current status.
_P2P_REQ	ARRAY	%FX16512	P2P enable/disable request	Changes the state of P2P enable/disable.
_P2P_REQ_NUM	ARRAY	%FX16528	Setting P2P enable/disable	Display setting P2P enable/disable.
_CYCLE_TASK_SCAN_TIME	ARRAY	%FW190	Scan time of fixed cycle task	Indicates max, min and current scan time of fixed cycle task.
_CYCLE_TASK_SCAN_WRT	BOOL	%FX16392	Initialize scan value of fixed cycle task	Initialize scan value of fixed cycle task.
_SOCKET_CLOSE_COUNTER	ARRAY	%FW996	CLOSE count of each sockets	Disconnection count with client per socket.
_RTC_TIME_USER[0]	BYTE	%FB2068	Time to set (year)	Change RTC information data(Year).
_RTC_TIME_USER[1]	BYTE	%FB2069	Time to set (month)	Change RTC information data(Month).
_RTC_TIME_USER[2]	BYTE	%FB2070	Time to set (Date)	Change RTC information data(Date).

Flag Name	TYPE	Memory	Content	Description
_RTC_TIME_USER[3]	BYTE	%FB2071	Time to set (hour)	Change RTC information data(Hour).
_RTC_TIME_USER[4]	BYTE	%FB2072	Time to set (minute)	Change RTC information data(minute).
_RTC_TIME_USER[5]	BYTE	%FB2073	Time to set (second)	Change RTC information data(second).
_RTC_TIME_USER[6]	BYTE	%FB2074	Time to set(day)	Change RTC information data(day).
_RTC_TIME_USER[7]	BYTE	%FB2075	Time to set (age)	Change RTC information data(Year).
_PLC_OPERATING_TIME	DWORD	%FD498	PLC Operation Time	PLC Operation Time(Sec) / Normal Type CPU
_PLC_OPERATING_TIME	DWORD	%FD501	PLC Operation Time	PLC Operation Time(Sec) / N Type CPU
_SOCKET1_ERR_CNT	DWORD	%FD504	Error frame counter 1	Local Ethernet Socket 1 error counter
_SOCKET2_ERR_CNT	DWORD	%FD505	Error frame counter 2	Local Ethernet Socket 2 error counter
_SOCKET3_ERR_CNT	DWORD	%FD506	Error frame counter 3	Local Ethernet Socket 3 error counter
_SOCKET4_ERR_CNT	DWORD	%FD507	Error frame counter 4	Local Ethernet Socket 4 error counter

A.3.3 Communication relay (L) list

(1) Special register for data link

High speed link No. 1 ~12

No.	keyword	Type	Content	Description
L000000	_HS1_RLINK	Bit	All stations of high speed link parameter No. 1 operate normally.	Indicates that all stations operate normally as per the parameter set from the high speed link. It becomes On in the following conditions. 1. When all stations set for the parameter are in RUN mode and there is no error 2. When all data blocks set for the parameter communicate normally 3. When the parameter set for each station set for the parameter communicates normally When Run_link becomes On, it will be maintained until it is stopped using link disable.
L000001	_HS1_LTRBL	Bit	Indicates abnormal state after _HS1RLINK ON	This flag becomes On when the communication status between the station set for the parameter and the data block while _HSmRLINK flag is On. 1. When the station set in the parameter is not in RUN mode 2. If a station set for the parameter has an error 3. If the communication status of the data block set for the parameter is unstable  Link trouble becomes On when a condition falling under 1,2 and 3 above occurs, and it becomes Off when the condition returns to normal.
L000002	_HS1_INPUT_CLR	Bit	HS Link 1 Receive Data Area Automatic Clear Setting in Receive Timeout	Turns on when "Input Data Set in an Emergency: Receive Area Data in Receive Timeout" is set to Latch among the high-speed link parameters.
L000020 ~ L00009F	_HS1_STATE[k] (k=000~127)	Bit array	Indicates the overall status of No. k block in high speed link parameter No. 1	Indicates the overall status of communication information for each data block of the set parameter.  HS1STATE[k]=HS1MOD[k]&_HS1TRX[k]&(~_HSmERR[k])
L000100 ~ L00017F	_HS1_MOD[k] (k=000~127)	Bit array	Run operation mode of No. K block station in high speed link parameter No. 1	Indicates the operation mode of the station set for k data block of the parameter.
L000180 ~ L00025F	_HS1_TRX[k] (k=000~127)	Bit array	Display of normal communication with No. k block station in high speed link parameter No. 1	Indicates whether the communication status of k data block in the parameter is carried out smoothly, as it is set, or not.
L000260 ~ L00033F	_HS1_ERR[k] (k=000~127)	Bit array	Operation error mode of No. K block station in high speed link parameter No. 1	Indicates whether an error occurred in the communication status of k data block in the parameter or not.
L000340 ~ L00041F	_HS1_SETBLOCK[k]	Bit array	Display of No. k block setting in high speed link parameter No. 1	Indicates the k data block setting status in the parameter.

High speed link number	Address in L area	Note
2	L000500~L00099F	<p>Compared with HS link 1, the flag address of other HS link station no. Is as follows.</p> <p>*Calculation formula: Address in L area = L000000 + 500 x (high speed link number-1)</p> <p>If you want to use HS link flag for program and monitoring, you can use the flag map registered in XG5000.</p>
3	L001000~L00149F	
4	L001500~L00199F	
5	L002000~L00249F	
6	L002500~L00299F	
7	L003000~L00349F	
8	L003500~L00399F	
9	L004000~L00449F	
10	L004500~L00499F	
11	L005000~L00549F	

k is the block number and the information of 128 blocks from 000 to 127 is shown as a total of 8 words, including 1 word for every 16 blocks. For example, in case of mode information (`_HS1MOD`), the information of block 0 to block 15 is shown in L00010, and the information of block 16~31, 32~47, 48~63, 64~79, 80~95, 96~111 and 112~127 is shown in L00011, L00012, L00013, L00014, L00015, L00016 and L00017 respectively. Therefore, the mode information of block number 55 is shown in L000137.

P2P parameter: 1 ~ 8 , P2P : 0 ~63

No.	keyword	Type	Content	Description
L006250	_P2P1_NDR00	Bit	P2P parameter No. 1 completed No. 00 block service normally	P2P parameter No. 1 completed No. 0 block service normally
L006251	_P2P1_ERR00	Bit	P2P parameter No. 1 completed No. 00 block service abnormally	P2P parameter No. 1 completed No. 0 block service abnormally
L00626	_P2P1_STATUS00	WORD	Error code in the case where P2P parameter No. 1 completed No. 00 block service abnormally	Error code is displayed when P2P parameter 1, 0 block service abnormal completion.
L00627	_P2P1_SVCCNT00	Double word	Number of No. 00 block service normal execution by P2P parameter No. 1	Displays the number of No. 0 block service executed normally by P2P parameter No. 1.
L00629	_P2P1_ERRCNT00	Double word	Number of No. 00 block service abnormal execution by P2P parameter No. 1	Displays the number of No. 0 block service executed normally by P2P parameter No. 1.
L006310	_P2P1_NDR01	Bit	P2P parameter No. 1 completed No. 01 block service normally	P2P parameter No. 1 completed No. 1 block service normally
L006311	_P2P1_ERR01	Bit	P2P parameter No. 1 completed No. 01 block service abnormally	P2P parameter No. 1 completed No. 1 block service abnormally
L00632	_P2P1_STATUS01	WORD	Error code in the case where P2P parameter No. 1 completed No. 01 block service abnormally	Error code is displayed when P2P parameter 1, 1 block service abnormal completion.
L00633	_P2P1_SVCCNT01	Double word	Number of No. 01 block service normal execution by P2P parameter No. 1	Displays the number of No. 1 block service executed normally by P2P parameter No. 1.
L00635	_P2P1_ERRCNT01	Double word	Number of No. 01 block service abnormal execution by P2P parameter No. 1	Displays the number of No. 1 block service executed normally by P2P parameter No. 1.

## (2) Link devices (N) list

P2P Number: 1 ~ 8 , P2P : 0 ~63

No.	keyword	Type	Content	Description
N00000	_P1B00SN	WORD	P2P parameter No. 1 No. 00 block destination station address	Saves the destination station address on No 00 block of P2P parameter No. 1. If the destination station address is used in XG5000, it can be modified during Run using P2PSN command.
N00001 ~ N00004	_P1B00RD1	Device structure	P2P parameter No. 1 No. 00 block area to read device 1	Saves device 1 on No. 00 block area to read of P2P parameter No. 1.
N00005	_P1B00RS1	WORD	P2P parameter No. 1 No. 00 block area to read size 1	Saves size 1 on No. 00 block area to read of P2P parameter No. 1.
N00006 ~ N00009	_P1B00RD2	Device structure	P2P parameter No. 1 No. 00 block area to read device 2	Saves device 2 on No. 00 block area to read of P2P parameter No. 1.
N00010	_P1B00RS2	WORD	P2P parameter No. 1 No. 00 block area to read size 2	Saves size 2 on No. 00 block area to read of P2P parameter No. 1.
N00011 ~ N00014	_P1B00RD3	Device structure	P2P parameter No. 1 No. 00 block area to read device 3	Saves device 3 on No. 00 block area to read of P2P parameter No. 1.
N00015	_P1B00RS3	WORD	P2P parameter No. 1 No. 00 block area to read size 3	Saves size 3 on No. 00 block area to read of P2P parameter No. 1.
N00016 ~ N00019	_P1B00RD4	Device structure	P2P parameter No. 1 No. 00 block area to read device 4	Saves device 4 on No. 00 block area to read of P2P parameter No. 1.
N00020	_P1B00RS4	WORD	P2P parameter No. 1 No. 00 block area to read size 4	Saves size 4 on No. 00 block area to read of P2P parameter No. 1.
N00021 ~ N00024	_P1B00WD1	Device structure	P2P parameter No. 1 No. 00 block save area device 1	Saves device 1 on No. 00 block save area of P2P parameter No. 1.
N00025	_P1B00WS1	WORD	P2P parameter No. 1 No. 00 block save area size 1	Saves size 1 on No. 00 block save area of P2P parameter No. 1.
N00026 ~ N00029	_P1B00WD2	Device structure	P2P parameter No. 1 No. 00 block save area device 2	Saves device 2 on No. 00 block save area of P2P parameter No. 1.
N00030	_P1B00WS2	WORD	P2P parameter No. 1 No. 00 block save area size 2	Saves size 2 on No. 00 block save area of P2P parameter No. 1.
N00031 ~ N00034	_P1B00WD3	Device structure	P2P parameter No. 1 No. 00 block save area device 3	Saves device 3 on No. 00 block save area of P2P parameter No. 1.
N00035	_P1B00WS3	WORD	P2P parameter No. 1 No. 00 block save area size 3	Saves size 3 on No. 00 block save area of P2P parameter No. 1.

No.	keyword	Type	Content	Description
N00036 ~ N00039	_P1B00WD4	Device structure	P2P parameter No. 1 No. 00 block save area device 4	Saves device 4 on No. 00 block save area of P2P parameter No. 1.
N00040	_P1B00WS4	WORD	P2P parameter No. 1 No. 00 block save area size 4	Saves size 4 on No. 00 block save area of P2P parameter No. 1.
N00041	_P1B01SN	WORD	P2P parameter No. 1 No. 01 block destination station address	Saves the destination station address on No 01 block of P2P parameter No. 1. If the destination station address is used in XG5000, it can be modified during Run using P2PSN command.
N00042 ~ N00045	_P1B01RD1	Device structure	P2P parameter No. 1 No. 01 block area to read device 1	Saves device 1 on No. 01 block area to read of P2P parameter No. 1.
N00046	_P1B01RS1	WORD	P2P parameter No. 1 No. 01 block area to read size 1	Saves size 1 on No. 01 block area to read of P2P parameter No. 1.
N00047 ~ N00050	_P1B01RD2	Device structure	P2P parameter No. 1 No. 01 block area to read device 2	Saves device 1 on No. 01 block area to read of P2P parameter No. 1.
N00051	_P1B01RS2	WORD	P2P parameter No. 1 No. 01 block area to read size 2	Saves size 2 on No. 01 block area to read of P2P parameter No. 1.
N00052 ~ N00055	_P1B01RD3	Device structure	P2P parameter No. 1 No. 01 block area to read device 3	Saves device 3 on No. 01 block area to read of P2P parameter No. 1.
N00056	_P1B01RS3	WORD	P2P parameter No. 1 No. 01 block area to read size 3	Saves size 3 on No. 01 block area to read of P2P parameter No. 1.
N00057 ~ N00060	_P1B01RD4	Device structure	P2P parameter No. 1 No. 01 block area to read device 4	Saves device 4 on No. 01 block area to read of P2P parameter No. 1.
N00061	_P1B01RS4	WORD	P2P parameter No. 1 No. 01 block area to read size 4	Saves size 4 on No. 01 block area to read of P2P parameter No. 1.
N00062 ~ N00065	_P1B01WD1	Device structure	P2P parameter No. 1 No. 01 block save area device 1	Saves device 1 on No. 01 block save area of P2P parameter No. 1.
N00066	_P1B01WS1	WORD	P2P parameter No. 1 No. 01 block save area size 1	Saves size 1 on No. 01 block save area of P2P parameter No. 1.
N00067 ~ N00070	_P1B01WD2	Device structure	P2P parameter No. 1 No. 01 block save area device 2	Saves device 2 on No. 01 block save area of P2P parameter No. 1.
N00071	_P1B01WS2	WORD	P2P parameter No. 1 No. 01 block save area size 2	Saves size 2 on No. 01 block save area of P2P parameter No. 1.
N00072 ~ N00075	_P1B01WD3	Device structure	P2P parameter No. 1 No. 01 block save area device 3	Saves device 3 on No. 01 block save area of P2P parameter No. 1.
N00076	_P1B01WS3	WORD	P2P parameter No. 1 No. 01 block save area size 3	Saves size 3 on No. 01 block save area of P2P parameter No. 1.
N00077 ~ N00080	_P1B01WD4	Device structure	P2P parameter No. 1 No. 01 block save area device 4	Saves device 4 on No. 01 block save area of P2P parameter No. 1.
N00081	_P1B01WS4	WORD	P2P parameter No. 1 No. 01 block save area size 4	Saves size 4 on No. 01 block save area of P2P parameter No. 1.

**Notes**

- (1) N area is automatically set when P2P parameter is set using XG5000 and can be modified during run using P2P dedicated command.
- (2) N area is classified according to P2P parameter setting number and block index number, so the area not used for P2P service can be used as internal device.

## (3) FEnet Connection information List

Variable	Type	Description
_0000_ADDR_LNM	WORD	FEnet : LNM information(above Ver 6.0)
_0000_CH_NFR	ARRAY	FEnet : New Frame Ready(Ver 8.6 or higher), (XGI CPU)
_0000_CH00_NFR ~ _0000_CH31_NFR	BIT	FEnet : New Frame Ready(Ver 8.6 or higher), (XGK CPU)
_0000_LINE_TOPOLOGY	BIT	FEnet : Line topology state(above Ver 6.0)
_0000_LINKUP_INFO	BIT	FEnet : Link up/down information
_0000_RING_TOPOLOGY	BIT	FEnet : Ring topology state(above Ver 6.0)
_0000_SC_INFO	WORD	FEnet : Server connection state
_0000_STAND_ALONE	BIT	FEnet : Stand alone state(above Ver 6.0)

It can add variables as FEnet module. For example, if there are FEnet modules in 1 and 3 slot, “\_0001\_~” and “\_0003\_~” are added as variable.

## A.4 ASCII Code Table

### American National Standard Code for Information Interchange

ASCII Code		Value	ASCII Code		Value	ASCII Code		Value	ASCII Code		Value
HEX	Decimal		HEX	Decimal		HEX	Decimal		HEX	Decimal	
00	000	NULL	40	064	@	80	128	€	C0	192	À
01	001	SOH	41	065	A	81	129	•	C1	193	Á
02	002	STX	42	066	B	82	130	,	C2	194	Â
03	003	ETX	43	067	C	83	131	ƒ	C3	195	Ã
04	004	EQT	44	068	D	84	132	„	C4	196	Ä
05	005	ENQ	45	069	E	85	133	...	C5	197	Å
06	006	ACK	46	070	F	86	134	†	C6	198	Æ
07	007	BEL	47	071	G	87	135	‡	C7	199	Ç
08	008	BS	48	072	H	88	136	^	C8	200	È
09	009	HT	49	073	I	89	137	‰	C9	201	É
0A	010	LF	4A	074	J	8A	138	Š	CA	202	Ê
0B	011	VT	4B	075	K	8B	139	‹	CB	203	Ë
0C	012	FF	4C	076	L	8C	140	Œ	CC	204	Ì
0D	013	CR	4D	077	M	8D	141	•	CD	205	Í
0E	014	SO	4E	078	N	8E	142	Ž	CE	206	Î
0F	015	SI	4F	079	O	8F	143	•	CF	207	Ï
10	016	DLE	50	080	P	90	144	•	D0	208	Ð
11	017	DC1	51	081	Q	91	145	‘	D1	209	Ñ
12	018	DC2	52	082	R	92	146	’	D2	210	Ò
13	019	DC3	53	083	S	93	147	“	D3	211	Ó
14	020	DC4	54	084	T	94	148	”	D4	212	Ô
15	021	NAK	55	085	U	95	149	•	D5	213	Õ
16	022	SYN	56	086	V	96	150	–	D6	214	Ö
17	023	ETB	57	087	W	97	151	—	D7	215	×
18	024	CAN	58	088	X	98	152	~	D8	216	Ø
19	025	EM	59	089	Y	99	153	™	D9	217	Ù
1A	026	SUB	5A	090	Z	9A	154	š	DA	218	Ú
1B	027	ESC	5B	091	[	9B	155	›	DB	219	Û

ASCII Code		Value	ASCII Code		Value	ASCII Code		Value	ASCII Code		Value
HEX	Decimal		HEX	Decimal		HEX	Decimal		HEX	Decimal	
1C	028	FS	5C	092	\	9C	156	œ	DC	220	Ü
1D	029	GS	5D	093	]	9D	157	•	DD	221	Ý
1E	030	RS	5E	094	^	9E	158	ž	DE	222	þ
1F	031	US	5F	095	_	9F	159	ÿ	DF	223	ß
20	032	(space)	60	096	`	A0	160		E0	224	à
21	033	!	61	097	a	A1	161	ı	E1	225	á
22	034	"	62	098	b	A2	162	ç	E2	226	â
23	035	#	63	099	c	A3	163	£	E3	227	ã
24	036	\$	64	100	d	A4	164	¤	E4	228	ä
25	037	%	65	101	e	A5	165	¥	E5	229	å
26	038	&	66	102	f	A6	166	ı	E9	230	æ
27	039	'	67	103	g	A7	167	§	EA	231	ç
28	040	(	68	104	h	A8	168	¨	EB	232	è
29	041	)	69	105	i	A9	169	©	EC	233	é
2A	042	*	6A	106	j	AA	170	ª	ED	234	ê
2B	043	+	6B	107	k	AB	171	«	EE	235	ë
2C	044	`	6C	108	l	AC	172	¬	EF	236	ì
2D	045	-	6D	109	m	AD	173		F0	237	í
2E	046	.	6E	110	n	AE	174	®	F1	238	î
2F	047	/	6F	111	o	AF	175	¯	F2	239	ï
30	048	0	70	112	p	B0	176	°	F3	240	ð
31	049	1	71	113	q	B1	177	±	F4	241	ñ
32	050	2	72	114	r	B2	178	²	F5	242	ò
33	051	3	73	115	s	B3	179	³	F6	243	ó
34	052	4	74	116	t	B4	180	´	F7	244	ô
35	053	5	75	117	u	B5	181	µ	F8	245	õ
36	054	6	76	118	v	B6	182	¶	F9	246	ö
37	055	7	77	119	w	B7	183	·	FA	247	÷
38	056	8	78	120	x	B8	184	¸	FB	248	ø
39	057	9	79	121	y	B9	185	¹	FC	249	ù
3A	058	:	7A	122	z	BA	186	º	FD	250	ú
3B	059	;	7B	123	{	BB	187	»	FE	251	û
3C	060	<	7C	124		BC	188	½	FF	252	ü
3D	061	=	7D	125	}	BD	189	¾	EF	253	ý
3E	062	>	7E	126	~	BE	190	¿	EF	254	þ

3F	063	?	7F	127	□	BF	191	À	EF	255	ÿ
----	-----	---	----	-----	---	----	-----	---	----	-----	---

### A.5 Ethernet technology compare table

Technology		Speed (Mbps)	Media	Max. distance
Token Ring		4.16	UTP	100m
Ethernet	10BASE-T	10	UTP	100m
	10BASE-F(Multi mode)	10	Optical cable	Max. 2km
	10BASE-F(Single mode)	10	Optical cable	Max. 2.5km
	10BASE-5	10	Coaxial cable	500m
	10BASE-2	10	Coaxial cable	185m
Fast Ethernet	100BASE-T4	100	UTP	100m
	100BASE-TX	100	UTP	100m
	100BASE-FX(Multi mode)	100	Optical cable	412m(Half Duplex) 2km(Full Duplex)
	100BASE-FX(Single mode)	100	Optical cable	20km
Gigabit Ethernet	1000BASE-T	1000	UTP	100m
	1000BASE-FX(Single mode)	1000	Optical cable	3km
	1000BASE-FX(Multi mode)	1000	Optical cable	500m
	1000BASE-T	1000	Coaxial cable	25m
100VG-AnyLAN		100	UTP	-
ATM		155-622	UTP,Optical cable	-
FDDI(Single mode)		100	Optical cable	40-60km
FDDI(Multi mode)		100	Optical cable	2km

**A.6 Dimension**

(1) XGL-EFMTB/EFMFB, XGL-EH5T

Unit : mm

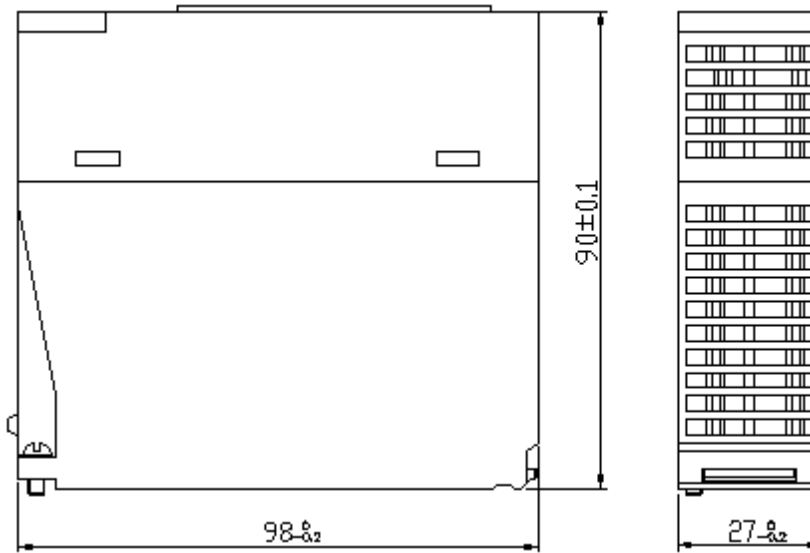

(2) XOL-ES4H

Unit : mm

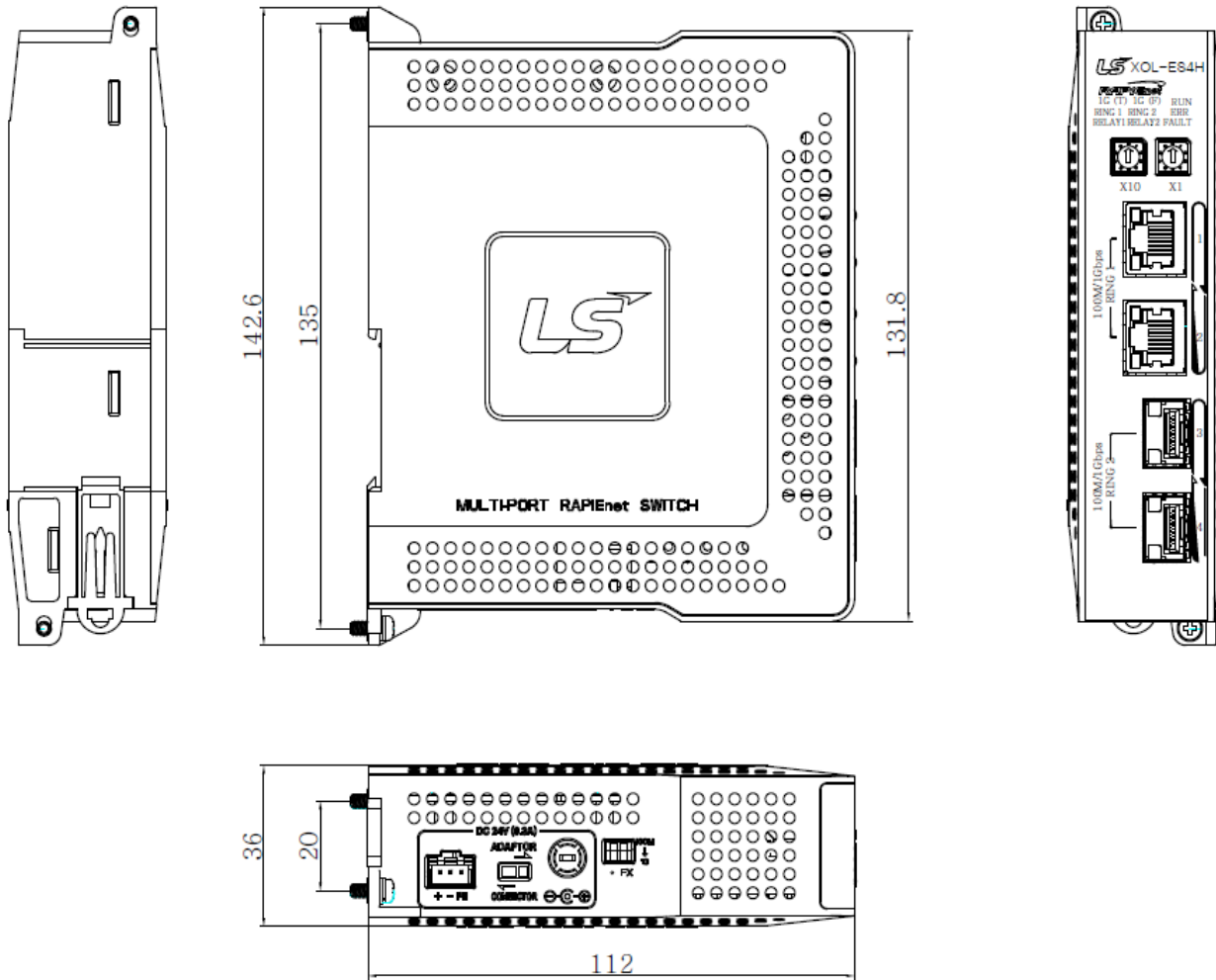

(3) XOL-ES4T

Unit : mm

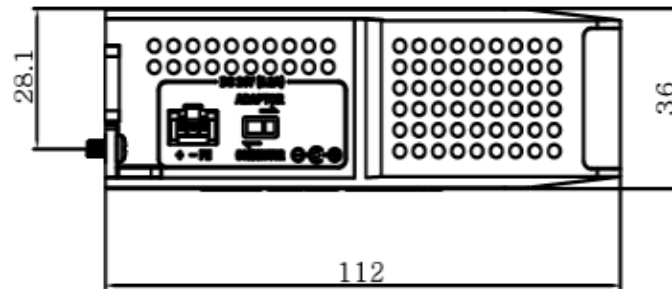
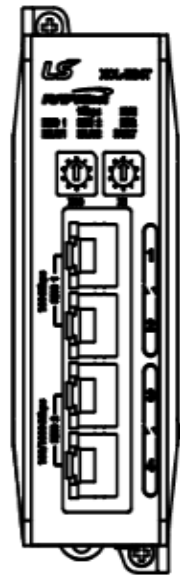
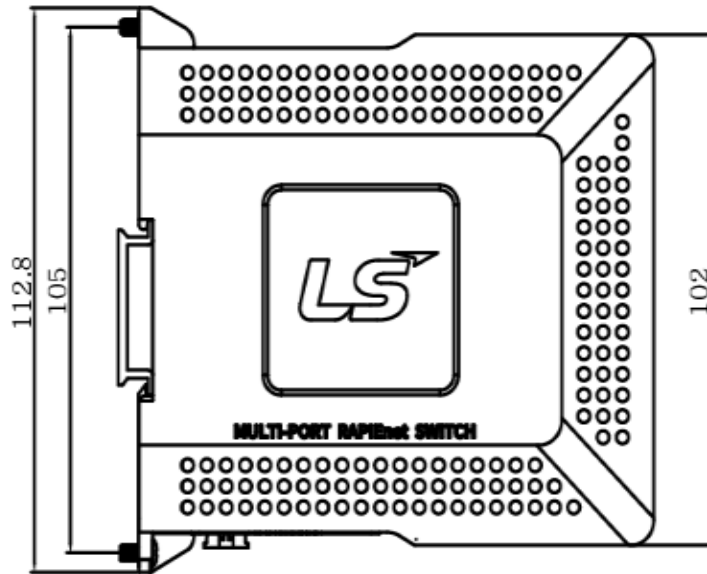
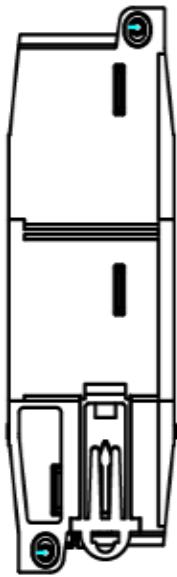

## Warranty

### 1. Warranty Period

The product you purchased is guaranteed for 36 months from the date of manufacture.

### 2. Scope of Warranty

- (1) The initial diagnosis of faults is basically conducted by your company. However, upon your request, our company or our service network can undertake this task for a fee. If the cause of the fault lies with our company, this service will be provided free of charge.
- (2) This warranty only applies if the product is used under normal conditions according to the specifications and precautions described in the handling instructions, user manuals, catalogs, and caution labels.
- (3) Even within the free warranty period, the following cases will be subject to paid repairs:
  - 1) Replacement of consumable and life-limited parts (e.g., relays, fuses, electrolytic capacitors, fans, LCDs, batteries, etc.)
  - 2) Failures or damages caused by improper storage, handling, negligence, or accidents by the customer
  - 3) Failures resulting from the customer's hardware or software design
  - 4) Failures due to modifications without our consent  
(Repairs will be refused, even for a fee, if recognized as modified or repaired outside our company)
  - 5) Failures that could have been avoided if the customer's equipment, in which our product is incorporated, had safety devices required by legal regulations or common industry standards
  - 6) Failures that could have been prevented if maintenance and replacement of consumable parts were performed normally according to the handling instructions or user manuals
  - 7) Failures and damages to the product caused by using connected equipment or inappropriate consumables
  - 8) Failures caused by external factors such as fire, abnormal voltage, force majeure, and natural disasters such as earthquakes, lightning, salt damage, wind, and flood damage
  - 9) Failures due to reasons that could not be predicted with the scientific and technical standards at the time of our shipment
  - 10) Other failures, damages, or defects recognized as the responsibility of your company

## Environmental Policy

LS ELECTRIC Co., Ltd supports and observes the environmental policy as below.

### Environmental Management

LS ELECTRIC considers the environmental preservation as the preferential management subject and every staff of LS ELECTRIC use the reasonable endeavors for the pleasurable environmental preservation of the earth.

### About disposal of the Product.

LS ELECTRIC' PLC unit is designed to protect the environment. For the disposal, separate aluminum, iron and synthetic resin (cover) from the product as they are reusable.





[www.ls-electric.com](http://www.ls-electric.com)

## LS ELECTRIC Co., Ltd.

### ■ Headquarter

LS-ro 127(Hogye-dong) Dongan-gu, Anyang-si, Gyeonggi-Do, 14119, Korea

### ■ Seoul Office

LS Yongsan Tower, 92, Hangang-daero, Yongsan-gu, Seoul, 04386, Korea

Tel: 82-2-2034-4033, 4888, 4703 Fax: 82-2-2034-4588

E-mail: [automation@ls-electric.com](mailto:automation@ls-electric.com)

### ■ Overseas Subsidiaries

#### • LS ELECTRIC Japan Co., Ltd. (Tokyo, Japan)

Tel: 81-3-6268-8241 E-Mail: [japan@ls-electric.com](mailto:japan@ls-electric.com)

#### • LS ELECTRIC (Dalian) Co., Ltd. (Dalian, China)

Tel: 86-411-8730-6495 E-Mail: [china.dalian@lselectric.com.cn](mailto:china.dalian@lselectric.com.cn)

#### • LS ELECTRIC (Wuxi) Co., Ltd. (Wuxi, China)

Tel: 86-510-6851-6666 E-Mail: [china.wuxi@lselectric.com.cn](mailto:china.wuxi@lselectric.com.cn)

#### • LS ELECTRIC Middle East FZE (Dubai, U.A.E.)

Tel: 971-4-886-5360 E-Mail: [middleeast@ls-electric.com](mailto:middleeast@ls-electric.com)

#### • LS ELECTRIC Europe B.V. (Hoofddorp, Netherlands)

Tel: 31-20-654-1424 E-Mail: [europartner@ls-electric.com](mailto:europartner@ls-electric.com)

#### • LS ELECTRIC America Inc. (Chicago, USA)

Tel: 1-800-891-2941 E-Mail: [sales.us@lselectricamerica.com](mailto:sales.us@lselectricamerica.com)

#### • LS ELECTRIC Turkey Co., Ltd.

Tel: 90-212-806-1225 E-Mail: [turkey@ls-electric.com](mailto:turkey@ls-electric.com)

### ■ Overseas Branches

#### • LS ELECTRIC Tokyo Office (Japan)

Tel: 81-3-6268-8241 E-Mail: [tokyo@ls-electric.com](mailto:tokyo@ls-electric.com)

#### • LS ELECTRIC Beijing Office (China)

Tel: 86-10-5095-1631 E-Mail: [china.auto@lselectric.com.cn](mailto:china.auto@lselectric.com.cn)

#### • LS ELECTRIC Shanghai Office (China)

Tel: 86-21-5237-9977 E-Mail: [china.auto@lselectric.com.cn](mailto:china.auto@lselectric.com.cn)

#### • LS ELECTRIC Guangzhou Office (China)

Tel: 86-20-3818-2883 E-Mail: [china.auto@lselectric.com.cn](mailto:china.auto@lselectric.com.cn)

#### • LS ELECTRIC Chengdu Office (China)

Tel: 86-28-8670-3201 E-Mail: [china.auto@lselectric.com.cn](mailto:china.auto@lselectric.com.cn)

#### • LS ELECTRIC Qingdao Office (China)

Tel: 86-532-8501-2065 E-Mail: [china.auto@lselectric.com.cn](mailto:china.auto@lselectric.com.cn)

#### • LS ELECTRIC Nanjing Office (China)

Tel: 86-25-8467-0005 E-Mail: [china.auto@lselectric.com.cn](mailto:china.auto@lselectric.com.cn)

#### • LS ELECTRIC Bangkok Office (Thailand)

Tel: 66-90-950-9683 E-Mail: [thailand@ls-electric.com](mailto:thailand@ls-electric.com)

#### • LS ELECTRIC Jakarta Office (Indonesia)

Tel: 62-21-2933-7614 E-Mail: [indonesia@ls-electric.com](mailto:indonesia@ls-electric.com)

#### • LS ELECTRIC Moscow Office (Russia)

Tel: 7-499-682-6130 E-Mail: [info@lselectric-ru.com](mailto:info@lselectric-ru.com)

#### • LS ELECTRIC America Western Office (Irvine, USA)

Tel: 1-949-333-3140 E-Mail: [america@ls-electric.com](mailto:america@ls-electric.com)

### Disclaimer of Liability

LS ELECTRIC has reviewed the information in this publication to ensure consistency with the hardware and software described. However, LS ELECTRIC cannot guarantee full consistency, nor be responsible for any damages or compensation, since variance cannot be precluded entirely. Please check again the version of this publication before you use the product.

© LS ELECTRIC Co., Ltd 2015 All Right Reserved.

2024.11