

BALDOR • RELIANCE

Customer information packet

CWDM3542-H

0.75HP, 1765RPM, 3PH, 60HZ, 56H, 3514M, TENV, F

Class - None

Division - Not Applicable

Specifications

Enclosure	TENV
Frame	56H
Frame Material	Steel
Frequency	60.00 Hz
Haz Area Class and Group	None
Haz Area Division	Not Applicable
Motor Letter Type	Three Phase
Output @ Frequency	.750 HP @ 60 HZ
Phase	3
Synchronous Speed @ Frequency	1800 RPM @ 60 HZ
Voltage @ Frequency	460.0 V @ 60 HZ 208.0 V @ 60 HZ 230.0 V @ 60 HZ
Agency Approvals	CSA UR
Ambient Temperature	40 °C
Auxillary Box	No Auxillary Box
Auxillary Box Lead Termination	None
Base Indicator	Rigid
Bearing Grease Type	Polyrex EM (-20F +300F)
Blower	None
Current @ Voltage	1.150 A @ 460.0 V 2.300 A @ 230.0 V 2.400 A @ 208.0 V
Design Code	B
Drip Cover	No Drip Cover
Duty Rating	CONT
Efficiency @ 100% Load	82.5 %
Electrically Isolated Bearing	Not Electrically Isolated
Feedback Device	NO FEEDBACK
Heater Indicator	No Heater
High Voltage Full Load Amps	1.2 a

Part detail

Revision	E
Type	AC
Mech. spec.	
Base	
Status	PRD/A
Elec. spec.	35WGG069
Layout	35LY-000-259
Eff. date	01-18-2024
CD Diagram	CD0005
Poles	04
Leads	9#18
Proprietary	False
Created date	10-28-2021

Insulation Class	F
Inverter Code	Inverter Ready
KVA Code	K
Lifting Lugs	No Lifting Lugs
Locked Bearing Indicator	No Locked Bearing
Motor Lead Termination	Flying Leads
Motor Standards	NEMA
Motor Type	3514M
Mounting Arrangement	F1
Number of Poles	4
Overall Length	11.91 IN
Power Factor	74
Product Family	Wash Down
Pulley Face Code	C-Face
Rodent Screen	None
Service Factor	1.00
Shaft Diameter	0.625 IN
Shaft Ground Indicator	No Shaft Grounding
Shaft Rotation	Reversible
Speed	1765 rpm
Speed Code	Single Speed
Starting Method	Direct on line
Thermal Device - Bearing	None
Thermal Device - Winding	None
Vibration Sensor Indicator	No Vibration Sensor
Winding Thermal 1	None
Winding Thermal 2	None

Nameplate

NP1496L									
CAT.NO.	CWDM3542-H								
SPEC.	35-0000-1372								
HP	.75								
VOLTS	208-230/460								
AMP	2.4/1.2								
RPM	1765								
FRAME	56HC		HZ	60		PH	3		
SER.F.	1.00	CODE	K	DES	B	CLASS	F		
NEMA-NOM-EFF	82.5	PF	74						
RATING	40C AMB-CONT								
CC									
DE	6205		ODE	6203					
ENCL	TENV	SN							

AC Induction Motor Performance Data

Record # 31358

Typical performance - not guaranteed values

Winding: 35WGP672-R002		Type: 3514M	Enclosure: TENV	
Nameplate Data			460 V, 60 Hz: High Voltage Connection	
Rated Output (HP)	.75	Full Load Torque	2.26 LB-FT	
Volts	230/460	Start Configuration	direct on line	
Full Load Amps	2.8/1.4	Breakdown Torque	11.5 LB-FT	
R.P.M.	1750	Pull-up Torque	6.93 LB-FT	
Hz	60 Phase	3	Locked-rotor Torque	7.71 LB-FT
NEMA Design Code	B KVA Code	M	Starting Current	10.5 A
Service Factor (S.F.)	1.25	No-load Current	1.07 A	
NEMA Nom. Eff.	78.5 Power Factor	66	Line-line Res. @ 25°C	21.9 Ω
Rating - Duty	40C AMB-CONT	Temp. Rise @ Rated Load		
S.F. Amps	3/1.5	Temp. Rise @ S.F. Load		

Load Characteristics 460 V, 60 Hz, 0.75 HP

% of Rated Load	25	50	75	100	125	150	S.F.
Power Factor	28	44	56	66	74	79	74
Efficiency	57.7	71.7	76.6	78.6	79	78.6	79
Speed	1789	1777	1766	1751	1736	1722	1736
Line amperes	1.08	1.14	1.22	1.36	1.52	1.69	1.52

ABB Motors and Mechanical Inc.

WINDING # 35WGP672

0.75 HP 3 PH 60 HZ 1750 RPM 460 V 3514M

Typical performance - not guaranteed values.

TORQUES (LB-FT): PO=11.5 PU=6.93 LR=7.71 LRA=10.5

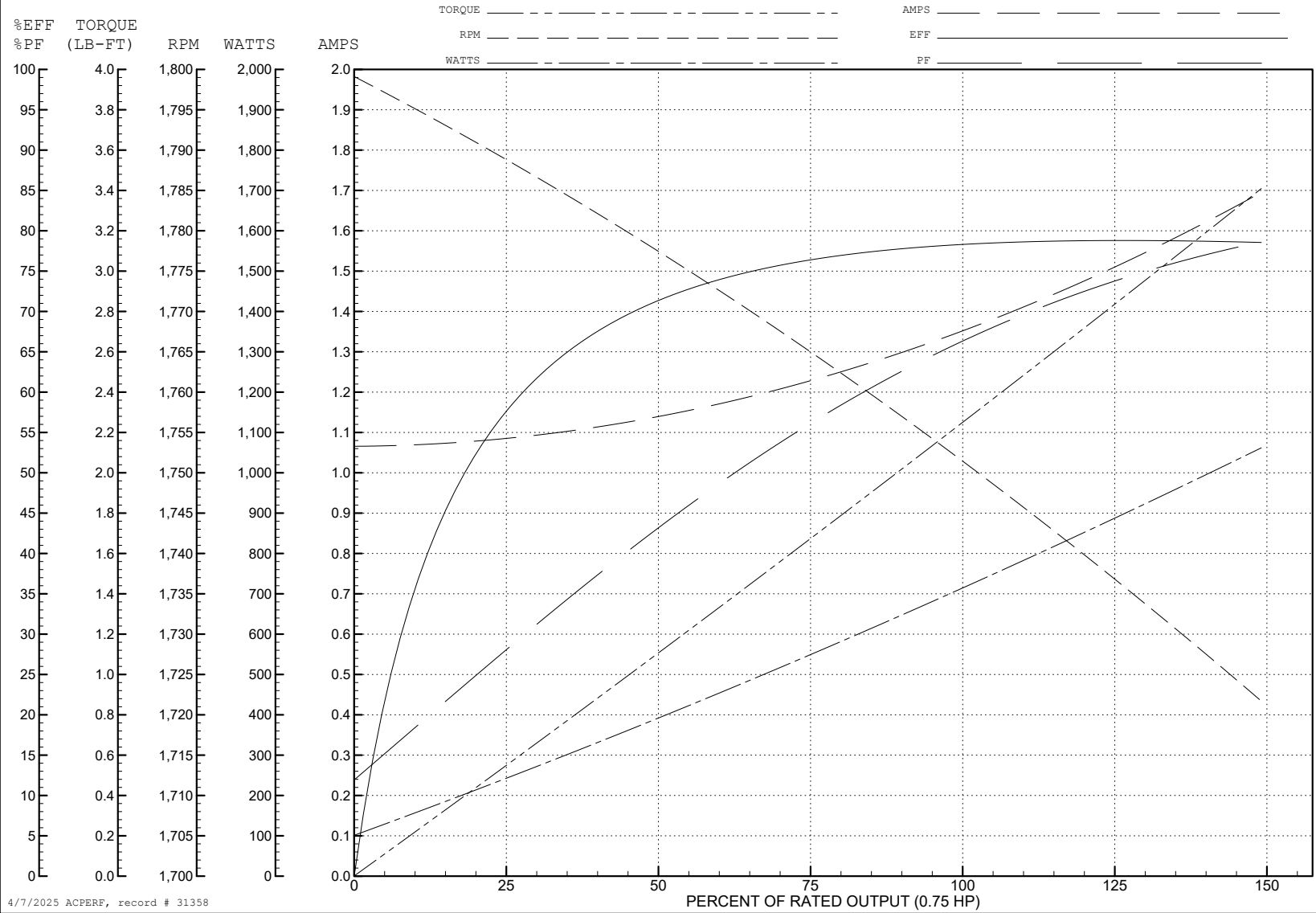

4/7/2025 ACPERF, record # 31358

35LY-000-259

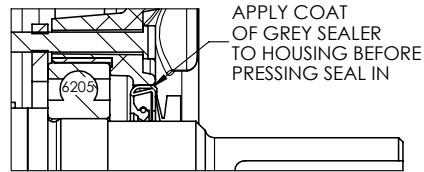
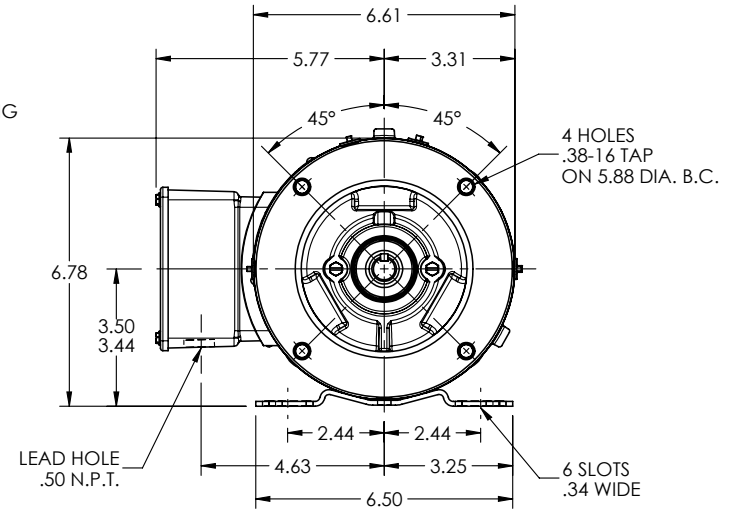
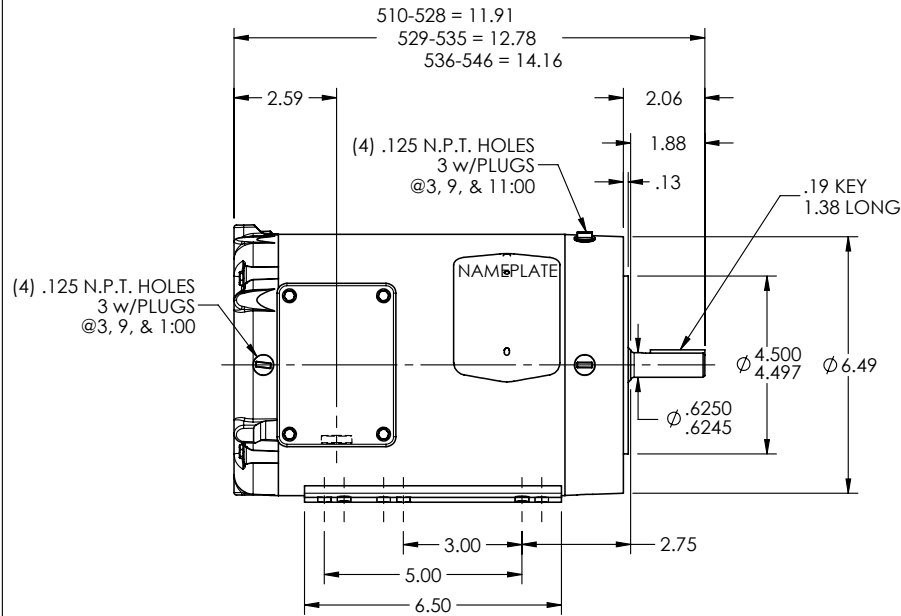

PULLEY END DETAIL

CUSTOMER IS RESPONSIBLE FOR DETERMINING THAT THE PRODUCT WILL PERFORM SUITABLY IN THE INTENDED APPLICATION

REV. DESC: UPDATE MATE ERRORS IN 3D MODEL			
REV: A	VERSION: 01	REVISED: 08:47:50 04/21/2022	TDR: 000001188385
6S7-000-1372		MODEL NO. 35LY-000-259	REF: -
		BY: USBUFRA	

BALDOR - RELIANCE®

STD HORZ 56HC TENV 35M WD

35LY-000-259

CD0005

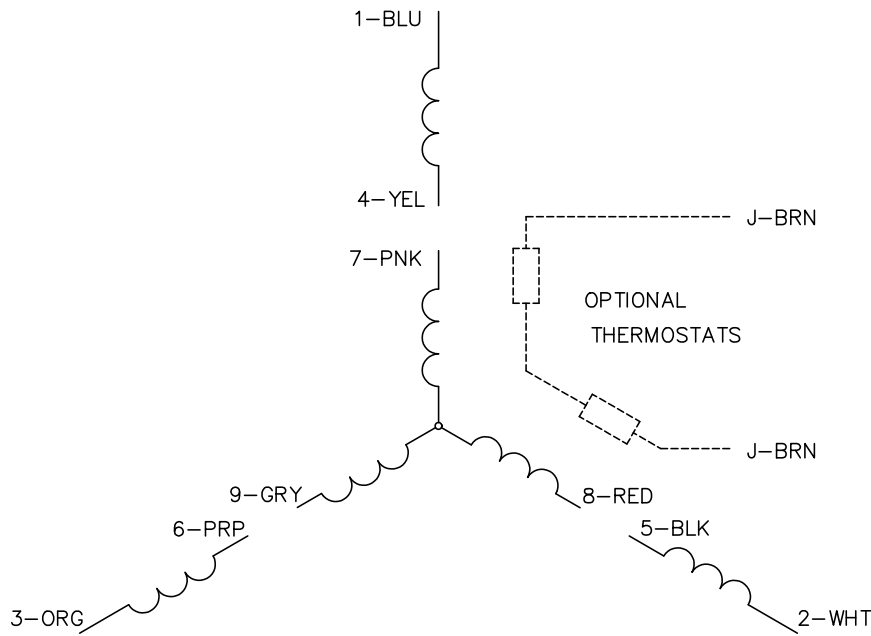

LOW VOLTAGE
(2Y)



HIGH VOLTAGE
(1Y)

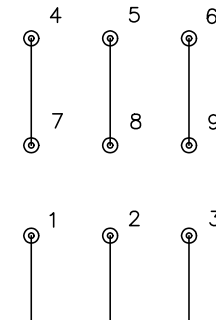

NOTES:

1. INTERCHANGE ANY TWO LINE LEADS TO REVERSE ROTATION.
2. OPTIONAL THERMOSTATS ARE PROVIDED WHEN SPECIFIED.
3. ACTUAL NUMBER OF INTERNAL PARALLEL CIRCUITS MAY BE A MULTIPLE OF THOSE SHOWN ABOVE.
4. LEAD COLORS ARE OPTIONAL. LEADS MUST ALWAYS BE NUMBERED AS SHOWN.

CD0005

REV. DESC: REVISE TO SHOW OPTIONAL COLORS			
REV. LTR: E	BY: JLP	REVISED: 01/19/99 10:15	TDR: 0171435
S00000		FILE: AAA00005140	MDL: -
		MTL: -	

BALDOR ELECTRIC Co.

3PH, DV, 9 LEADS