

BALDOR • RELIANCE

Customer information packet

EJM3545-5

1HP, 3450RPM, 3PH, 60HZ, 56J, 3420M, TEFC, F1, N

Class - None

Division - Not Applicable

Copyright © All product information within this document is subject to ABB Motors and Mechanical Inc. copyright © protection, unless otherwise noted.

4/7/2025 11:12:19 AM

Specifications

Enclosure	TEFC
Frame	56J
Frame Material	Steel
Frequency	60.00 Hz
Haz Area Class and Group	None
Haz Area Division	Not Applicable
Motor Letter Type	Three Phase
Output @ Frequency	1.000 HP @ 60 HZ
Phase	3
Synchronous Speed @ Frequency	3600 RPM @ 60 HZ
Voltage @ Frequency	575.0 V @ 60 HZ
Agency Approvals	CSA EEV CSA UR
Ambient Temperature	40 °C
Auxillary Box	No Auxillary Box
Auxillary Box Lead Termination	None
Base Indicator	No Mounting
Bearing Grease Type	Polyrex EM (-20F +300F)
Blower	None
Current @ Voltage	1.200 A @ 575.0 V
Design Code	B
Drip Cover	No Drip Cover
Duty Rating	CONT
Efficiency @ 100% Load	77.0 %
Electrically Isolated Bearing	Not Electrically Isolated
Feedback Device	NO FEEDBACK
Front Face Code	Standard
Front Shaft Indicator	None
Heater Indicator	No Heater
High Voltage Full Load Amps	1.2 a
Insulation Class	B

Part detail

Revision	G
Type	AC
Mech. spec.	34K508
Base	
Status	PRD/A
Elec. spec.	34WG3623
Layout	34LYK508
Eff. date	10-29-2024
CD Diagram	CD0006
Poles	02
Leads	3#18
Proprietary	False
Created date	07-07-2016

Inverter Code	Not Inverter
KVA Code	N
Lifting Lugs	No Lifting Lugs
Locked Bearing Indicator	Locked Bearing
Motor Lead Exit	Ko Box
Motor Lead Quantity/Wire Size	3 @ 18 AWG
Motor Lead Termination	Flying Leads
Motor Standards	NEMA
Motor Type	3420M
Mounting Arrangement	F1
Number of Poles	2
Overall Length	12.47 IN
Power Factor	80
Product Family	General Purpose
Pulley End Bearing Type	Ball
Pulley Face Code	C-Face
Pulley Shaft Indicator	Ext Thread
Rodent Screen	None
RoHS Status	ROHS COMPLIANT
Service Factor	1.40
Shaft Diameter	0.625 IN
Shaft Extension Location	Pulley End
Shaft Ground Indicator	No Shaft Grounding
Shaft Rotation	Reversible
Shaft Slinger Indicator	No Slinger
Speed	3450 rpm
Speed Code	Single Speed
Starting Method	Direct on line
Thermal Device - Bearing	None
Thermal Device - Winding	None
Vibration Sensor Indicator	No Vibration Sensor
Winding Thermal 1	None
Winding Thermal 2	None

Nameplate

NP1259L									
CAT.NO.	EJM3545-5								
SPEC.	34K508-3623G2								
HP	1								
VOLTS	575								
AMP	1.2								
RPM	3450								
FRAME	56J		HZ	60		PH	3		
SER.F.	1.40	CODE	N	DES	B	CL	B		
NEMA-NOM-EFF	77	PF	80						
RATING	40C AMB-CONT								
CC	010A								
DE	6203		ODE	6203					
ENCL	TEFC	SN							
	SFA 1.5								

AC Induction Motor Performance Data

Record # 6692

Typical performance - not guaranteed values

Winding: 34WG3623-R001		Type: 3420M		Enclosure: TEFC	
Nameplate Data			575 V, 60 Hz: Single Voltage Motor		
Rated Output (HP)	1	Full Load Torque	1.5 LB-FT		
Volts	575	Start Configuration	direct on line		
Full Load Amps	1.3	Breakdown Torque	7 LB-FT		
R.P.M.	3450	Pull-up Torque	5 LB-FT		
Hz	60	Locked-rotor Torque	5.5 LB-FT		
NEMA Design Code	B	Starting Current	10 A		
Service Factor (S.F.)	1.4	No-load Current	0.7 A		
NEMA Nom. Eff.	73	Line-line Res. @ 25°C	20 Ω		
Rating - Duty	40C AMB-CONT	Temp. Rise @ Rated Load	55°C		
S.F. Amps	1.5	Temp. Rise @ S.F. Load	78°C		
		Locked-rotor Power Factor	64		
		Rotor inertia	0.0186 LB-FT ²		

Load Characteristics 575 V, 60 Hz, 1 HP

% of Rated Load	25	50	75	100	125	150	S.F.
Power Factor	42	60	71	78	82	85	84
Efficiency	61.1	73.5	77.6	79	78.9	78.1	78.8
Speed	3569	3543	3513	3480	3448	3413	3429
Line amperes	0.8	0.9	1	1.2	1.4	1.8	1.6

ABB Motors and Mechanical Inc.

WINDING # 34WG3623

Typical performance - not guaranteed values.

1 HP 3 PH 60 HZ 3450 RPM 575 V 3420M

TORQUES (LB-FT): PO=7 PU=5 LR=5.5 LRA=10

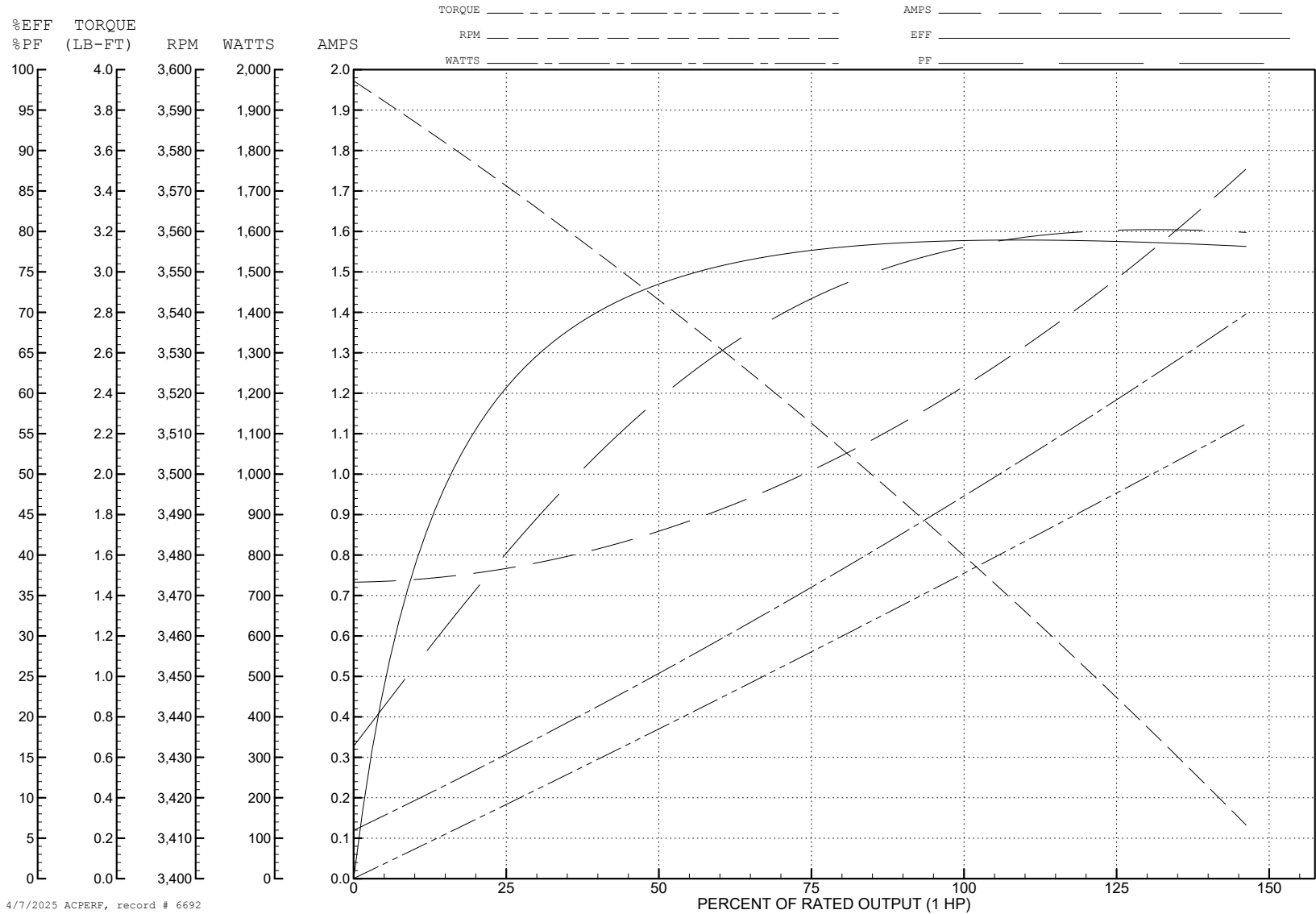

4/7/2025 ACPERF, record # 6692

34LYK508

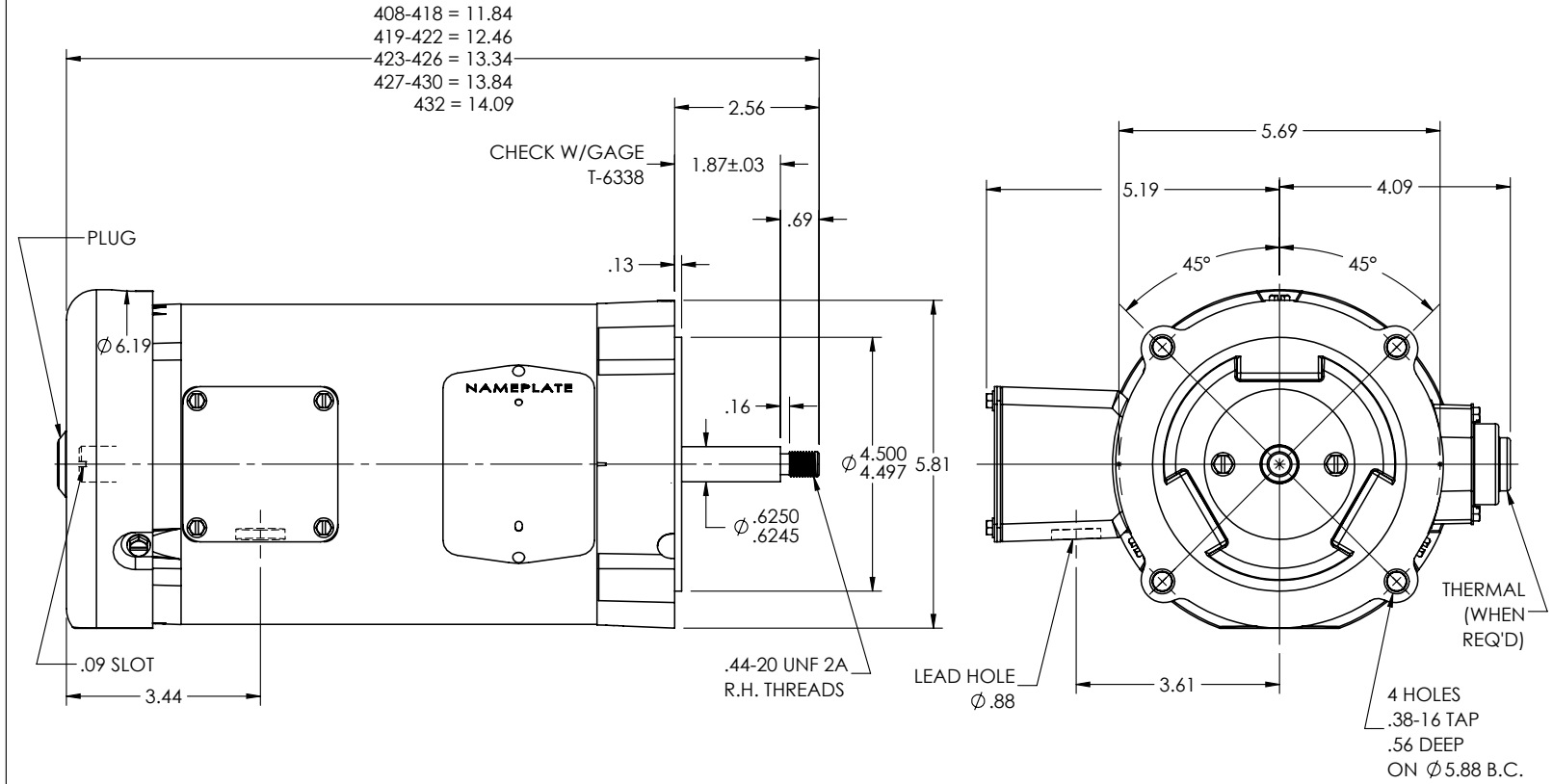

CUSTOMER IS RESPONSIBLE FOR DETERMINING THAT THE PRODUCT WILL PERFORM SUITABLY IN THE INTENDED APPLICATION

REV. DESC: LOAD TO SOLIDWORKS - REV B

REV: C | VERSION: 03 | REVISED: 09:07:52 12/20/2022 | TDR: 000001201165

34LYK508

MODEL NO. 34LYK508
 BY: ENFRAJ0

REF: -

BALDOR - RELIANCE®

VER 34M NEMA 56J TEFC F/LOW RES ER

34LYK508

CD0006



NOTES:

1. THREE LEAD MOTOR MAY BE EITHER WYE CONNECTED OR DELTA CONNECTED.
2. INTERCHANGE ANY TWO LINE LEADS TO REVERSE ROTATION.
3. OPTIONAL THERMOSTATS ARE PROVIDED WHEN SPECIFIED.
4. ACTUAL NUMBER OF INTERNAL PARALLEL CIRCUITS MAY VARY.
5. LEAD COLORS ARE OPTIONAL. LEADS MUST BE NUMBERED AS SHOWN.

CD0006

REV. DESC: ADD CLASS CONN00000007		
REV. LTR: E	VERSION: 01	TDR: 000001099922
FILE: \AAA\00005\141	REVISED: 10:24:49 02/19/2019	BY: ENBRIRO
MTL: -		© □

BALDOR - RELIANCE®

3PH, SV, 3 LEADS, WYE OR DELTA CONNECTED

SH 1 of 1