



Customer information packet

EM3610T-5

3HP, 3450RPM, 3PH, 60HZ, 182T, 3532M, TEFC, F1

Class - None

Division - Not Applicable

Specifications

Enclosure	TEFC
Frame	182T
Frame Material	Steel
Frequency	60.00 Hz
Haz Area Class and Group	None
Haz Area Division	Not Applicable
Motor Letter Type	Three Phase
Output @ Frequency	3.000 HP @ 60 HZ
Phase	3
Synchronous Speed @ Frequency	3600 RPM @ 60 HZ
Voltage @ Frequency	575.0 V @ 60 HZ
Agency Approvals	NEMA PREMIUM CURUSEEV
Ambient Temperature	40 °C
Auxillary Box	No Auxillary Box
Auxillary Box Lead Termination	None
Base Indicator	Rigid
Bearing Grease Type	Polyrex EM (-20F +300F)
Blower	None
Current @ Voltage	2.900 A @ 575.0 V
Design Code	B
Drip Cover	No Drip Cover
Duty Rating	CONT
Efficiency @ 100% Load	86.5 %
Electrically Isolated Bearing	Not Electrically Isolated
Feedback Device	NO FEEDBACK
Front Face Code	Standard
Front Shaft Indicator	None
Heater Indicator	No Heater
High Voltage Full Load Amps	2.9 a
Insulation Class	F
Inverter Code	Inverter Ready

Part detail

Revision	K
Type	AC
Mech. spec.	35L100
Base	
Status	PRD/A
Elec. spec.	35WGM839
Layout	35LYL100
Eff. date	07-27-2024
CD Diagram	CD0006
Poles	02
Leads	3#18
Proprietary	False
Created date	08-22-2013

KVA Code	L
Lifting Lugs	No Lifting Lugs
Locked Bearing Indicator	No Locked Bearing
Motor Lead Exit	Ko Box
Motor Lead Quantity/Wire Size	3 @ 18 AWG
Motor Lead Termination	Flying Leads
Motor Standards	NEMA
Motor Type	3532M
Mounting Arrangement	F1
Number of Poles	2
Overall Length	15.16 IN
Power Factor	92
Product Family	General Purpose
Pulley End Bearing Type	Ball
Pulley Face Code	Standard
Pulley Shaft Indicator	Standard
Rodent Screen	None
RoHS Status	ROHS COMPLIANT
Service Factor	1.15
Shaft Diameter	1.125 IN
Shaft Extension Location	Pulley End
Shaft Ground Indicator	No Shaft Grounding
Shaft Rotation	Reversible
Shaft Slinger Indicator	No Slinger
Speed	3450 rpm
Speed Code	Single Speed
Starting Method	Direct on line
Thermal Device - Bearing	None
Thermal Device - Winding	None
Vibration Sensor Indicator	No Vibration Sensor
Winding Thermal 1	None
Winding Thermal 2	None

Nameplate

NP1259L									
CAT.NO.	EM3610T-5								
SPEC.	35L100M839G1								
HP	3								
VOLTS	575								
AMP	2.9								
RPM	3450								
FRAME	182T		HZ	60		PH	3		
SER.F.	1.15	CODE	L	DES	B	CL	F		
NEMA-NOM-EFF	86.5	PF	92						
RATING	40C AMB-CONT								
CC	010A								
DE	6206		ODE	6203					
ENCL	TEFC	SN							

AC Induction Motor Performance Data

Record # 32143

Typical performance - not guaranteed values

Winding: 35WGM839-R001		Type: 3532M	Enclosure: TEFC		
Nameplate Data			575 V, 60 Hz: Single Voltage Motor		
Rated Output (HP)	3	Full Load Torque	4.5 LB-FT		
Volts	575	Start Configuration	direct on line		
Full Load Amps	2.9	Breakdown Torque	17.8 LB-FT		
R.P.M.	3450	Pull-up Torque	10.9 LB-FT		
Hz	60 Phase	3	Locked-rotor Torque	15.8 LB-FT	
NEMA Design Code	B	KVA Code	L	Starting Current	26.1 A
Service Factor (S.F.)	1.15	No-load Current	0.948 A		
NEMA Nom. Eff.	86.5	Power Factor	92	Line-line Res. @ 25°C	7.47 Ω
Rating - Duty	40C AMB-CONT		Temp. Rise @ Rated Load	61°C	
S.F. Amps			Temp. Rise @ S.F. Load	74°C	
			Locked-rotor Power Factor	47	
			Rotor inertia	0.0885 LB-FT ²	

Load Characteristics 575 V, 60 Hz, 3 HP

% of Rated Load	25	50	75	100	125	150	S.F.
Power Factor	58	77	86	88	89	90	89
Efficiency	83.8	87.9	88.1	87.2	85.5	83.4	86.2
Speed	3562	3531	3497	3461	3419	3373	3436
Line amperes	1.19	1.67	2.23	2.88	3.6	4.32	3.31

ABB Motors and Mechanical Inc.

WINDING # 35WGM839

3 HP 3 PH 60 HZ 3450 RPM 575 V 3532M

Typical performance - not guaranteed values.

TORQUES (LB-FT): PO=17.8 PU=10.9 LR=15.8 LRA=26.1

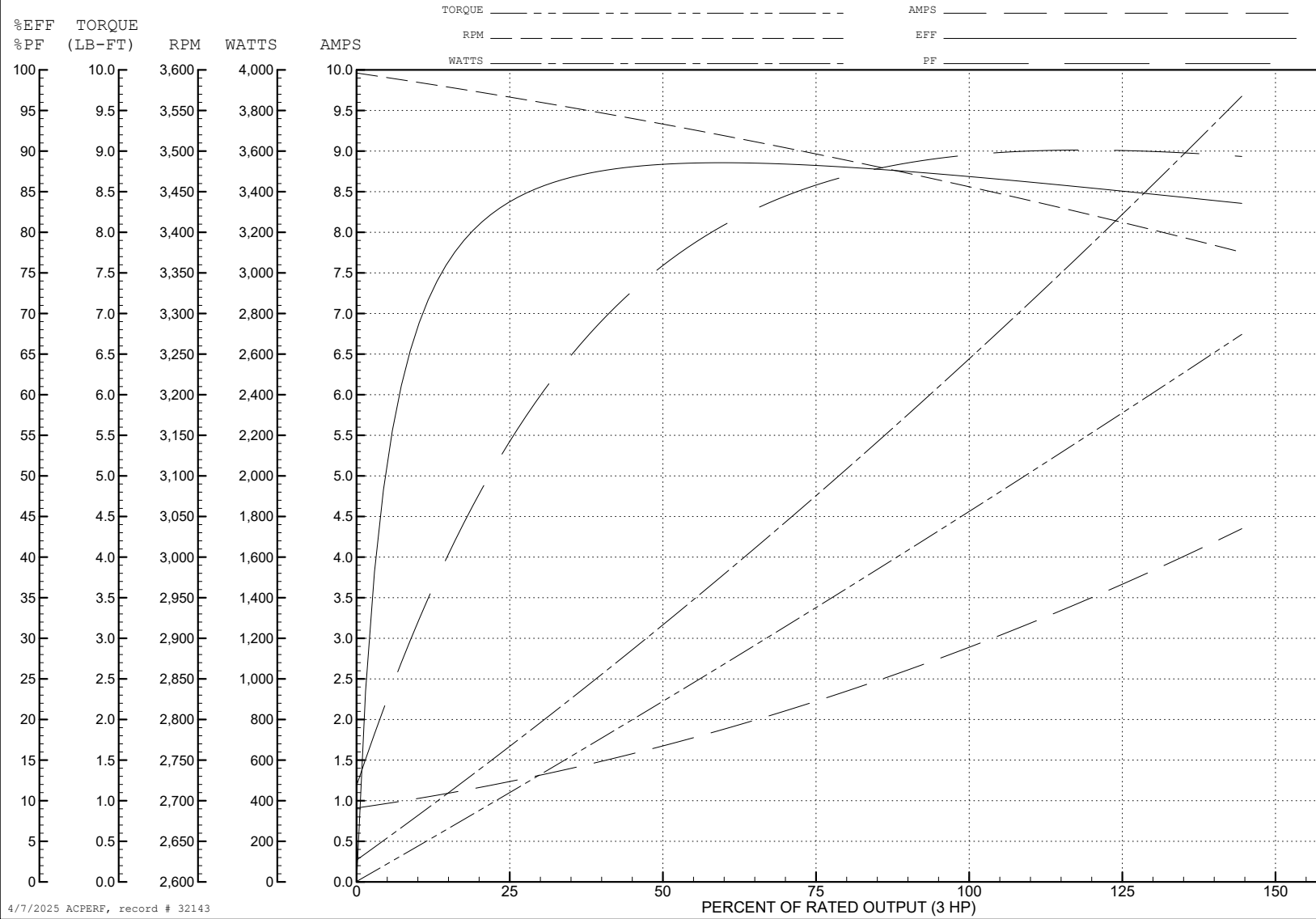

4/7/2025 ACPERF, record # 32143

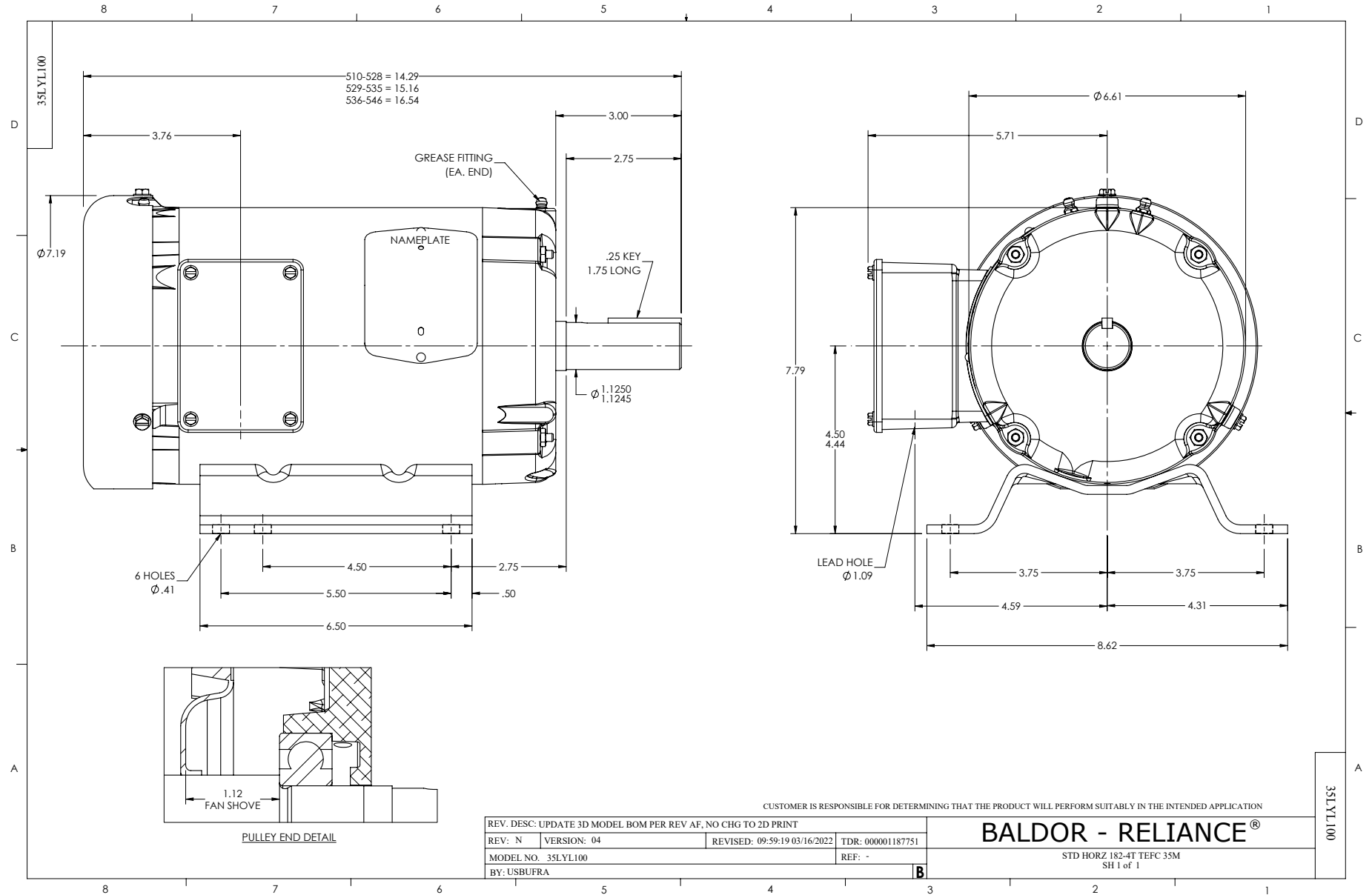

CD0006

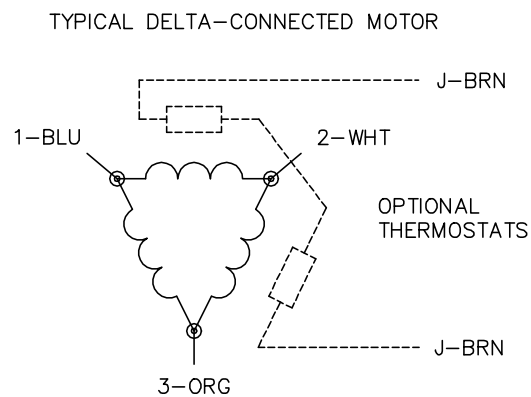
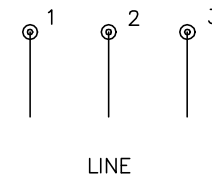
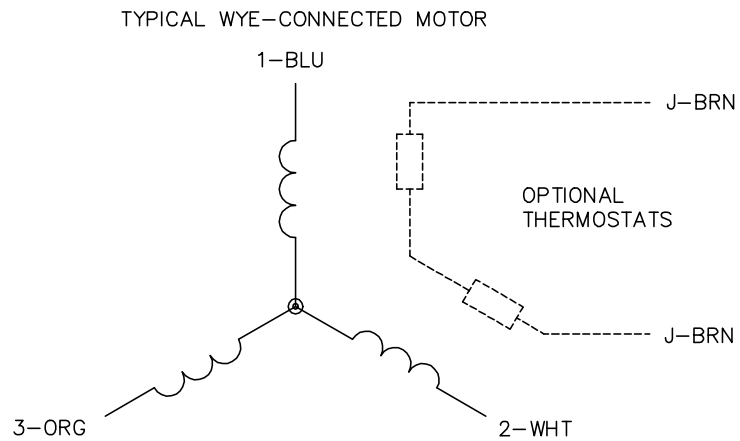

NOTES:

1. THREE LEAD MOTOR MAY BE EITHER WYE CONNECTED OR DELTA CONNECTED.
2. INTERCHANGE ANY TWO LINE LEADS TO REVERSE ROTATION.
3. OPTIONAL THERMOSTATS ARE PROVIDED WHEN SPECIFIED.
4. ACTUAL NUMBER OF INTERNAL PARALLEL CIRCUITS MAY VARY.
5. LEAD COLORS ARE OPTIONAL. LEADS MUST BE NUMBERED AS SHOWN.

CD0006

REV. DESC: ADD CLASS CONN00000007		
REV. LTR: E	VERSION: 01	TDR: 000001099922
FILE: \AAA\00005\141	REVISED: 10:24:49 02/19/2019	BY: ENBRIRO
MTL: -	© □	

BALDOR - RELIANCE®

3PH, SV, 3 LEADS, WYE OR DELTA CONNECTED

SH 1 of 1