

BALDOR • RELIANCE

Customer information packet

JMEWDM4115T

50HP, 1770RPM, 3PH, 60HZ, 326JM, TEFC, F1

Class - None

Division - Not Applicable

Copyright © All product information within this document is subject to ABB Motors and Mechanical Inc. copyright © protection, unless otherwise noted.

4/7/2025 12:03:36 PM

Specifications

Enclosure	TEFC
Frame	326JM
Frame Material	Iron
Frequency	60.00 Hz
Haz Area Class and Group	None
Haz Area Division	Not Applicable
Motor Letter Type	Three Phase
Output @ Frequency	50.000 HP @ 60 HZ
Phase	3
Synchronous Speed @ Frequency	1800 RPM @ 60 HZ
Voltage @ Frequency	230.0 V @ 60 HZ 460.0 V @ 60 HZ
Agency Approvals	CSA CSA EEV NEMA PREMIUM UR
Ambient Temperature	40 °C
Auxillary Box	No Auxillary Box
Auxillary Box Lead Termination	None
Base Indicator	Rigid
Bearing Grease Type	Polyrex EM (-20F +300F)
Blower	None
Current @ Voltage	57.000 A @ 460.0 V 114.000 A @ 230.0 V
Design Code	B
Drip Cover	No Drip Cover
Duty Rating	CONT
Efficiency @ 100% Load	94.5 %
Electrically Isolated Bearing	Not Electrically Isolated
Feedback Device	NO FEEDBACK
Heater Indicator	No Heater
High Voltage Full Load Amps	57.0 a

Part detail

Revision	G
Type	AC
Mech. spec.	
Base	
Status	PRD/A
Elec. spec.	12WGY627
Layout	12LYL057
Eff. date	02-21-2024
CD Diagram	CD0005
Poles	04
Leads	9#8
Proprietary	False
Created date	01-13-2020

Insulation Class	F
Inverter Code	Inverter Duty
IP Rating	NONE
KVA Code	G
Lifting Lugs	Standard Lifting Lugs
Locked Bearing Indicator	Locked Bearing
Max Speed	2700 rpm
Motor Lead Termination	Flying Leads
Motor Standards	NEMA
Motor Type	1272M
Mounting Arrangement	F1
Number of Poles	4
Overall Length	30.53 IN
Power Factor	87
Product Family	Washdown Features
Pulley Face Code	C-Face
Rodent Screen	None
Service Factor	1.15
Shaft Diameter	1.375 IN
Shaft Ground Indicator	No Shaft Grounding
Shaft Rotation	Reversible
Speed	1770 rpm
Speed Code	Single Speed
Starting Method	Direct on line
Thermal Device - Bearing	None
Thermal Device - Winding	None
Vibration Sensor Indicator	No Vibration Sensor
Winding Thermal 1	None
Winding Thermal 2	None

Nameplate

NP1669L									
CAT.NO.	JMEWDM4115T								
SPEC.	12-0000-1418								
HP	50								
VOLTS	230/460								
AMP	114/57								
RPM	1770								
FRAME	326JM		HZ	60		PH	3		
SER.F.	1.15	CODE	G	DES	B	CLASS	F		
NEMA-NOM-EFF	94.5	PF	87						
RATING	40C AMB-CONT								
CC	010A								
DE	6312		ODE	6311					
ENCL	TEFC	SN							
BLANK	20:1 CT & VT,1.0SF								

AC Induction Motor Performance Data

Record # 56626

Typical performance - not guaranteed values

Winding: 12WGY627-R003		Type: 1272M		Enclosure: TEFC		
Nameplate Data			460 V, 60 Hz: High Voltage Connection			
Rated Output (HP)	50		Full Load Torque	148 LB-FT		
Volts	230/460		Start Configuration	direct on line		
Full Load Amps	114/57		Breakdown Torque	446 LB-FT		
R.P.M.	1770		Pull-up Torque	183 LB-FT		
Hz	60	Phase	3	Locked-rotor Torque	254 LB-FT	
NEMA Design Code	B		KVA Code	G	Starting Current	344 A
Service Factor (S.F.)	1		No-load Current	18.3 A		
NEMA Nom. Eff.	94.5	Power Factor	87	Line-line Res. @ 25°C	0.119 Ω	
Rating - Duty	40C AMB-CONT		Temp. Rise @ Rated Load	61°C		
			Locked-rotor Power Factor	24.4		
			Rotor inertia	9.59 lb-ft ²		

Load Characteristics 460 V, 60 Hz, 50 HP

% of Rated Load	25	50	75	100	125	150
Power Factor	58	78	85	87	87	87
Efficiency	92.1	94.7	94.9	94.5	93.9	92.9
Speed	1791	1785	1779	1772	1765	1756
Line amperes	22.3	31.9	43.5	56.9	71.3	87.1

ABB Motors and Mechanical Inc.

WINDING # 12WGY627

Typical performance - not guaranteed values.

50 HP 3 PH 60 HZ 1770 RPM 460 V 1272M

TORQUES (LB-FT): PO=446 PU=183 LR=254 LRA=344

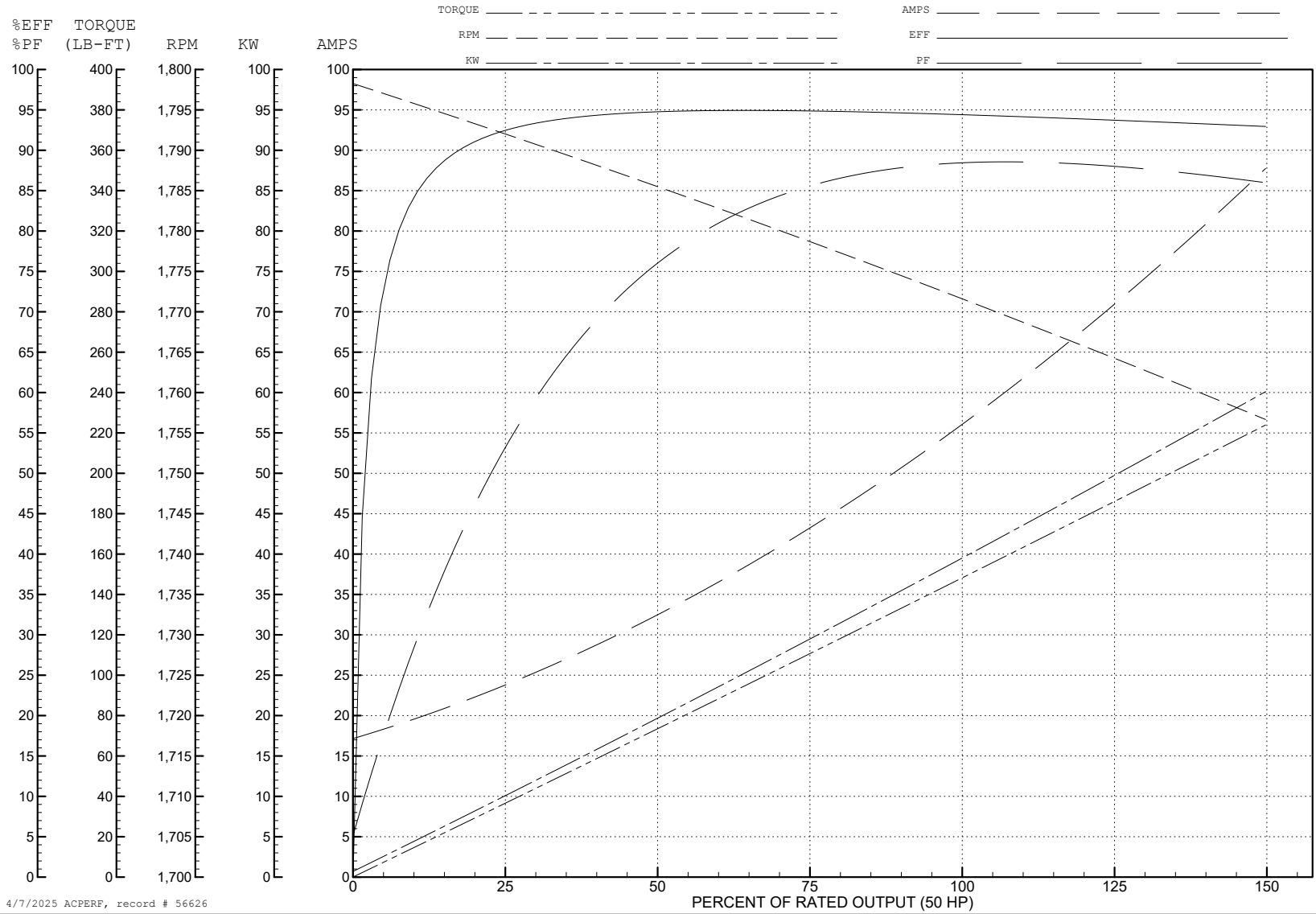

4/7/2025 ACPERF, record # 56626

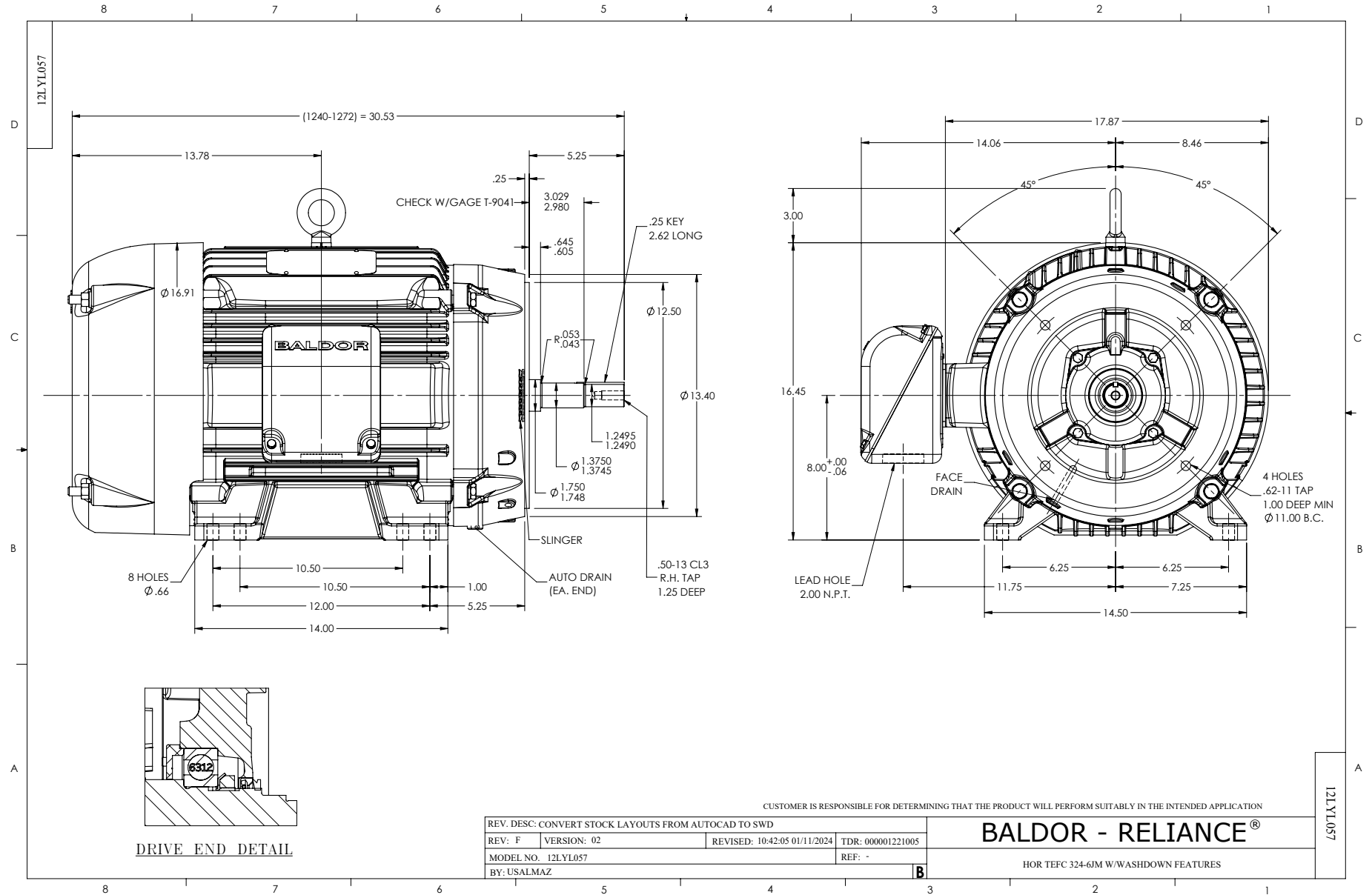

CD0005

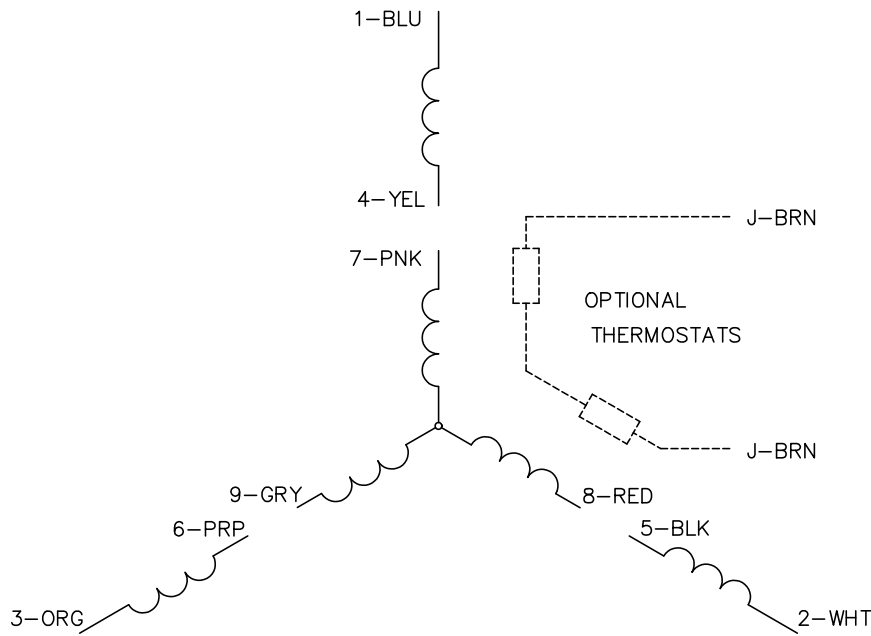

LOW VOLTAGE
(2Y)

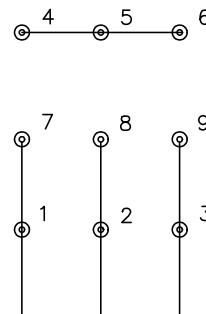

LINE

HIGH VOLTAGE
(1Y)

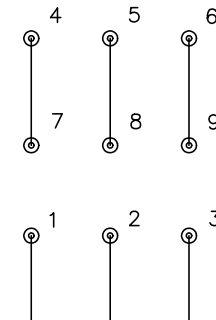

LINE

NOTES:

1. INTERCHANGE ANY TWO LINE LEADS TO REVERSE ROTATION.
2. OPTIONAL THERMOSTATS ARE PROVIDED WHEN SPECIFIED.
3. ACTUAL NUMBER OF INTERNAL PARALLEL CIRCUITS MAY BE A MULTIPLE OF THOSE SHOWN ABOVE.
4. LEAD COLORS ARE OPTIONAL. LEADS MUST ALWAYS BE NUMBERED AS SHOWN.

CD0005

REV. DESC: REVISE TO SHOW OPTIONAL COLORS			
REV. LTR: E	BY: JLP	REVISED: 01/19/99 10:15	TDR: 0171435
S00000		FILE: AAA00005140	MDL: -
		MTL: -	

BALDOR ELECTRIC Co.

3PH, DV, 9 LEADS