



---

# Customer information packet

## XL040542A

.5HP, 1725RPM, 1PH, 60HZ, 48, 3424L, XPFC, F1, N  
Class - CLI GP D; CLII GP F,G  
Division - Division I

## Specifications

Enclosure	XPFC
Frame	48
Frame Material	Steel
Frequency	60.00 Hz
Haz Area Class and Group	CLI GP D; CLII GP F,G
Haz Area Division	Division I
Motor Letter Type	Cap Start, Induction Run
Output @ Frequency	.500 HP @ 60 HZ
Phase	1
Synchronous Speed @ Frequency	1800 RPM @ 60 HZ
Voltage @ Frequency	230.0 V @ 60 HZ 115.0 V @ 60 HZ 208.0 V @ 60 HZ
Agency Approvals	CSA UL
Ambient Temperature	40 °C
Auxillary Box	No Auxillary Box
Auxillary Box Lead Termination	None
Base Indicator	Rigid
Bearing Grease Type	Polyrex EM (-20F +300F)
Blower	None
Current @ Voltage	3.700 A @ 230.0 V 3.900 A @ 208.0 V 7.400 A @ 115.0 V
Design Code	N
Drip Cover	No Drip Cover
Duty Rating	CONT
Efficiency @ 100% Load	64.0 %
Electrically Isolated Bearing	Not Electrically Isolated
Feedback Device	NO FEEDBACK
Haz Area Temp Code	T3C
Heater Indicator	No Heater

## Part detail

Revision	E
Type	AC
Mech. spec.	
Base	
Status	PRD/A
Elec. spec.	34WGW369
Layout	34LY6414
Eff. date	09-04-2024
CD Diagram	CD0565
Poles	04
Leads	6#18,1#16 #4TH
Proprietary	False
Created date	04-21-2021

High Voltage Full Load Amps	3.7 a
Insulation Class	B
Inverter Code	Not Inverter
IP Rating	NONE
KVA Code	J
Lifting Lugs	No Lifting Lugs
Locked Bearing Indicator	No Locked Bearing
Motor Lead Termination	Flying Leads
Motor Standards	NEMA
Motor Type	3424L
Mounting Arrangement	F1
Number of Poles	4
Overall Length	13.84 IN
Power Factor	66
Product Family	Hazardous Location Motor
Pulley Face Code	Standard
Rodent Screen	None
Service Factor	1.00
Shaft Diameter	0.500 IN
Shaft Ground Indicator	No Shaft Grounding
Shaft Rotation	Reversible
Speed	1725 rpm
Speed Code	Single Speed
Starting Method	Direct on line
Thermal Device - Bearing	None
Thermal Device - Winding	None
Vibration Sensor Indicator	No Vibration Sensor
Winding Thermal 1	Automatic Thermal Overload
Winding Thermal 1 Location	EP
Winding Thermal 2	None

**Nameplate**

NP0016XPSL					
<b>NO.</b>		<b>CC</b>			
<b>SER. #</b>					
<b>SPEC</b>	34-0000-0415				
<b>CAT.NO.</b>	XL040542A				
<b>H.P.</b>	.5	<b>T. CODE</b>	T3C		
<b>VOLTS</b>	115/208-230				
<b>AMPS</b>	7.4/3.9-3.7				
<b>R.P.M.</b>	1725 34WGW369				
<b>HZ</b>	60	<b>PH</b>	1	<b>CLASS</b>	B
<b>SER.F.</b>	1.00	<b>DES</b>	N	<b>CODE</b>	J
<b>RATING</b>	40C AMB-CONT				
<b>FRAME</b>	48	<b>NEMA NOM. EFF</b>	64		
	<b>PF</b>	66			
<b>BLANK</b>	NEMA MG-1 PART 5, IP54				

**AC Induction Motor Performance Data**

Record # 48773

Typical performance - not guaranteed values

Winding: 34WGW369-R001		Type: 3424L	Enclosure: XPFC	
<b>Nameplate Data</b>			<b>115 V, 60 Hz: Low Voltage Connection</b>	
Rated Output (HP)	.5	Full Load Torque	1.5 LB-FT	
Volts	115/208-230	Start Configuration	direct on line	
Full Load Amps	7.4/3.9-3.7	Breakdown Torque	4.4 LB-FT	
R.P.M.	1725	Pull-up Torque	4 LB-FT	
Hz	60 Phase	1	Locked-rotor Torque	5.1 LB-FT
NEMA Design Code	N KVA Code	J	Starting Current	38.8 A
Service Factor (S.F.)		1	No-load Current	5.62 A
NEMA Nom. Eff.	64 Power Factor	66	Line-line Res. @ 25°C	0.913 Ω A Ph 2.88 Ω B Ph
Rating - Duty	40C AMB-CONT		Temp. Rise @ Rated Load	61°C
			Locked-rotor Power Factor	89.3
			Rotor inertia	0.057 LB-FT <sup>2</sup>

**Load Characteristics 115 V, 60 Hz, 0.5 HP**

% of Rated Load	25	50	75	100	125	150
Power Factor	37	48	59	67	74	79
Efficiency	38.9	55.3	62.3	64.9	65.3	63.8
Speed	1781	1768	1753	1736	1717	1696
Line amperes	5.78	6.12	6.62	7.38	8.26	9.38

ABB Motors and Mechanical Inc.

WINDING # 34WGW369

Typical performance - not guaranteed values.

0.5 HP 1 PH 60 HZ 1725 RPM 115 V 3424L

TORQUES (LB-FT) : PO=4.4 PU=4 LR=5.1 LRA=38.8

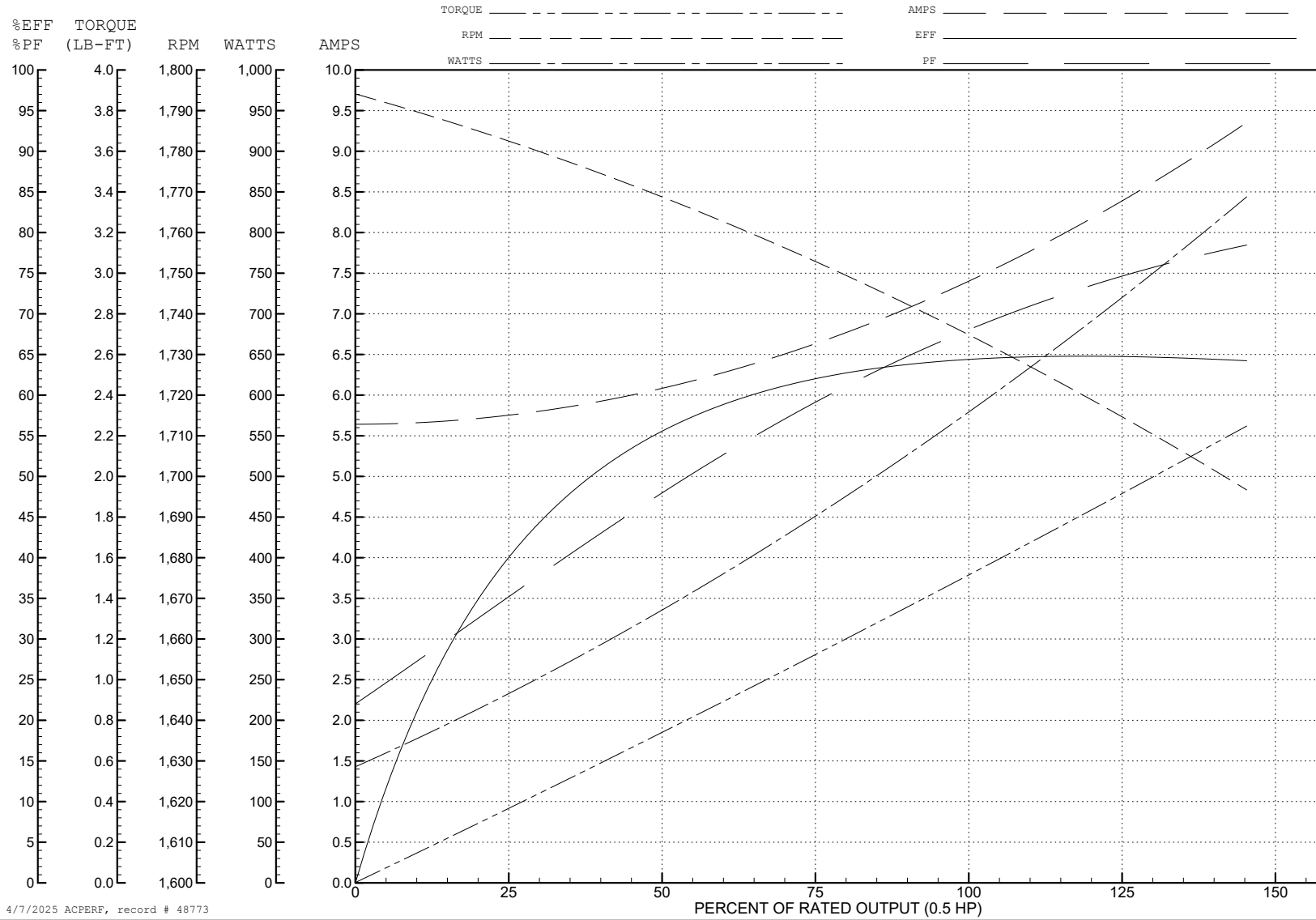

4/7/2025 ACPERP, record # 48773

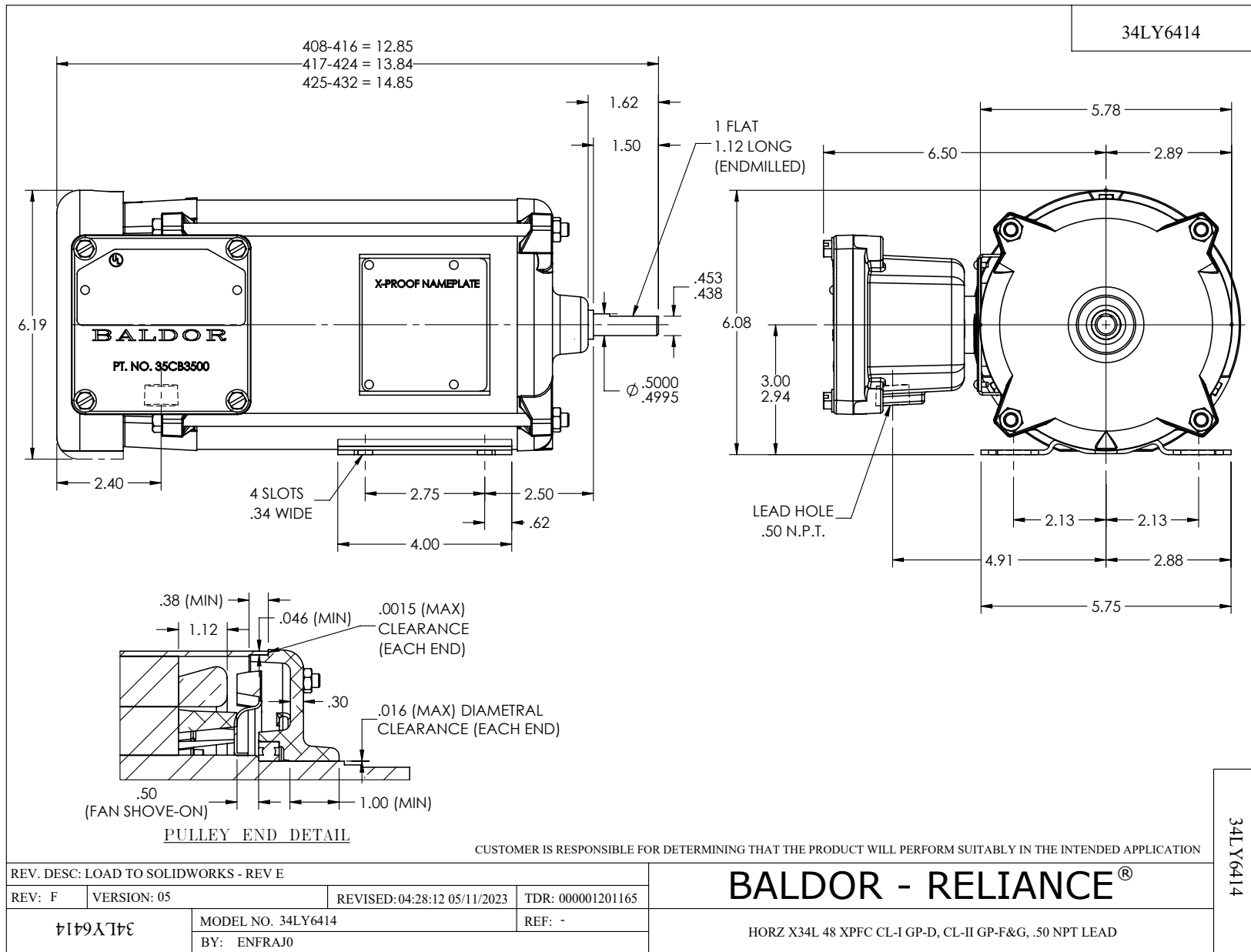

CD0565

8-RED 1-BLU 2-WHT 3-ORG 4-YEL J-BRN 5-BLK

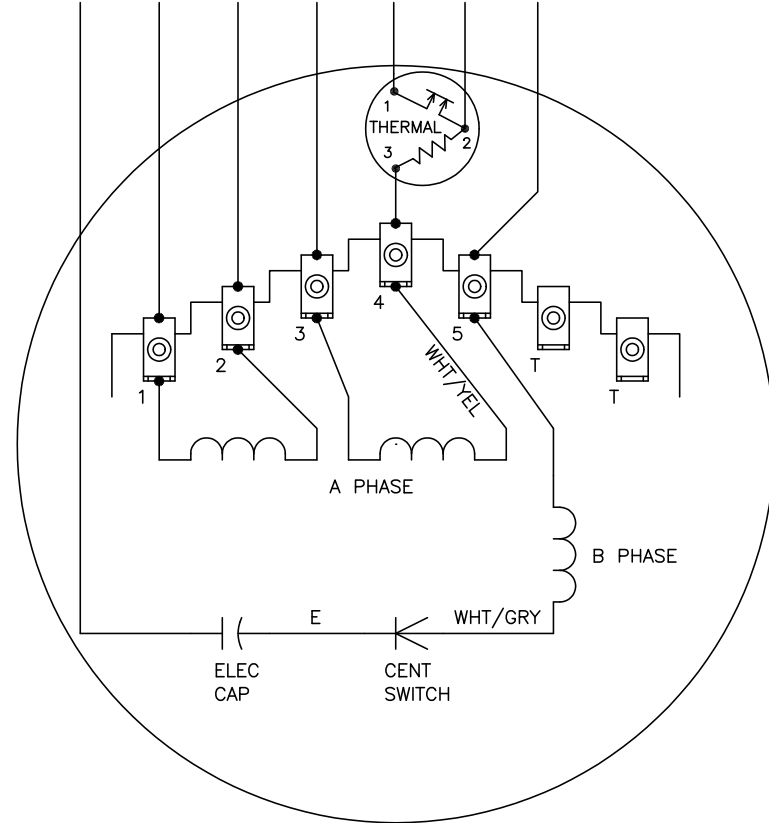

	LINE A	LINE B	JOIN	JOIN
HIGH STD	1	4	2,3,8	J,5
HIGH OPP	1	4	2,3,5	J,8
LOW STD	1,3,8	4	-	2,J,5
LOW OPP	1,3,5	4	-	2,J,8

NOTES:

1. STANDARD ROTATION IS CCW FACING END OPPOSITE SHAFT EXTENSION.
2. MULTIPLE CAPACITORS ARE CONNECTED IN PARALLEL UNLESS OTHERWISE SPECIFIED.
3. LEAD COLORS ARE OPTIONAL. LEADS MUST ALWAYS BE NUMBERED AS SHOWN.

CONNECTIONS FOR TWO-TERMINAL THERMAL

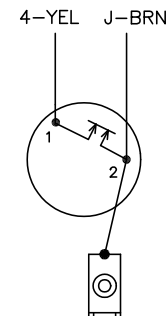

REV. DESC: REVISE TO SHOW OPTIONAL COLORS			
REV. LTR: C	BY: JLP	REVISED: 04/08/99 3:25	TDR: 0178636
99000		FILE: AAA00014311	MDL: -
		MTL: -	

**BALDOR ELECTRIC Co.**

TYPE L, DV, REV, THERMAL, 7 LD, 34XP

CD0565