

Chains & sprockets	Wear strips	Side guide brackets & accessories	Levelers
Modular belts & sprockets	Chain & belt return systems	Frame & structure supports	Bearings
Curves & tracks	Side guide solutions	Miscellaneous products	Related information

1 1 4 2 0 a

1873 VG

www.SystemPlastSmartGuide.com

Sidelfexing plate top chains base roller chains (Pitch 19,05 mm - 3/4") with high friction surface



Click here for related information.

K 750

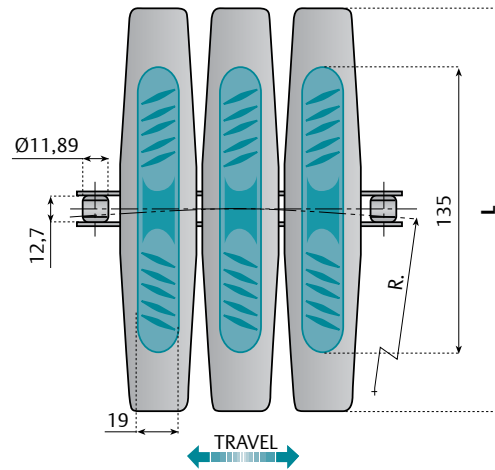
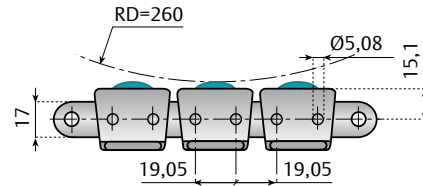
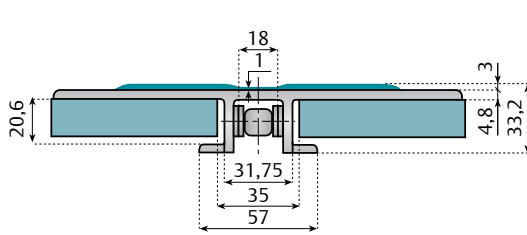

Nolu®-S curves

are strongly recommended with these chains!

K 1200

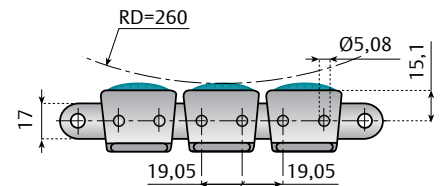
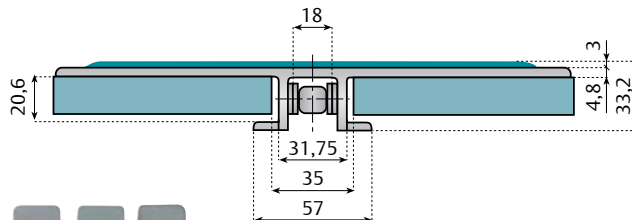

- Advantages:**
- High speed
 - Very high loads
 - Longer conveyors
 - Easy maintenance
 - Flights removable
 - Lower noise
 - No chain elongation

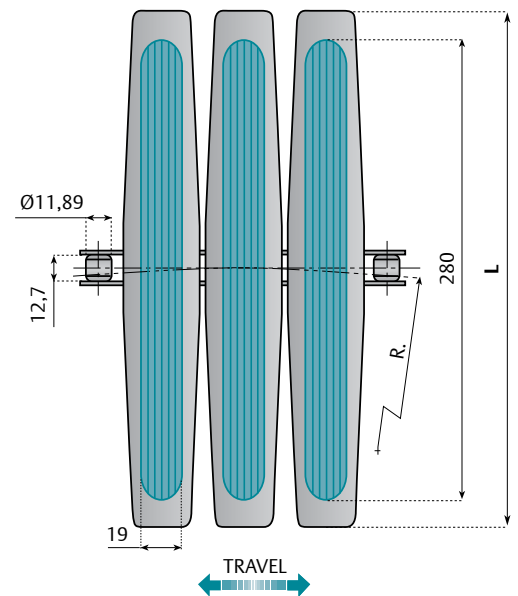

Note:
ANSI 60 roller chain

Item description	Material		Breaking load N	Width L		R min.	Weight Kg/m
	Roller chains	Plate		Rubber	mm		
NGD1873-K750VG	C45	NGD	27.000	190,5	7 ½	500	2,6
NGD1873SS-K750VG	SS	Dark Grey	21.000				
LFG1873-K1200VG	C45	LFG	27.000	304,8	12	610	3,8
LFG1873SS-K1200VG	SS	Dark Grey	21.000				

Standard length: 80 pitches (10 ft. - 3,048 m)

Breaking load according to standard ISO 4348 - DIN 8153