

Bushings

TAPER-LOCK STYLE

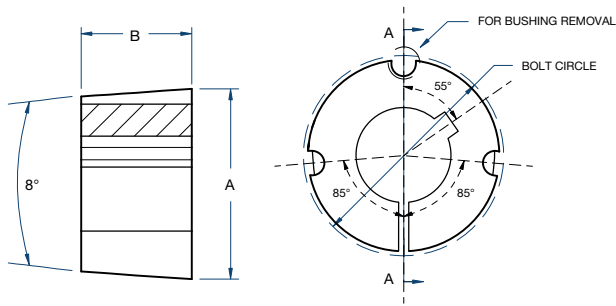

BLACKSTAR®



No. 1008-3030 Bushings

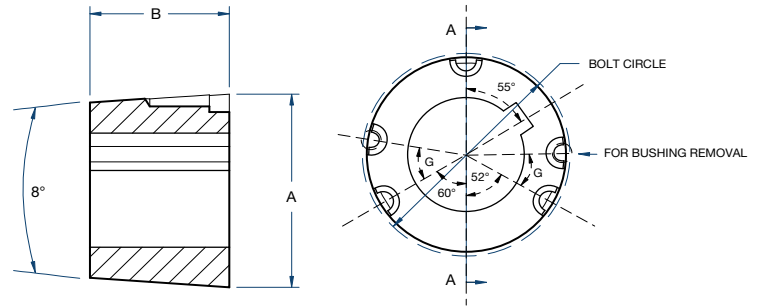

No. 3535-5050 Bushings

Bushing Number	Dimensions (in)		Bolt Circle	Installation Screws (UNC)		Stock Bore Range (in)			G	Wrench Torque (in-lbs)	Torque Application Capacity (in-lbs)	Approx. Weight (lbs)
	A	B		Thread Dia. (in)	Length (in)	Min.	Max.					
							Standard Keyway	Shallow Keyway*				
1008	1.386	7/8	1-21/64	1/4	1/2	1/2	7/8	1	—	55	1,200	0.2 - 0.3
1108	1.511	7/8	1-29/64	1/4	1/2	1/2	1	1-1/8	—	55	1,300	0.2 - 0.3
1210	1-7/8	1	1-3/4	3/8	5/8	1/2	1-1/4	—	—	175	3,600	0.4 - 0.6
1215	1-7/8	1-1/2	1-3/4	3/8	5/8	1/2	1-1/4	—	—	175	3,550	0.5 - 0.9
1310	2	1	1-7/8	3/8	5/8	1/2	1-3/8	—	—	175	3,850	0.4 - 0.7
1610	2-1/4	1	2-1/8	3/8	5/8	1/2	1-1/2	1-5/8	—	175	4,300	0.5 - 0.9
1615	2-1/4	1-1/2	2-1/8	3/8	5/8	1/2	1-1/2	1-5/8	—	175	4,300	0.6 - 1.3
2012	2-3/4	1-1/4	2-5/8	7/16	7/8	1/2	1-7/8	2	—	280	7,150	0.9 - 1.7
2517	3-3/8	1-3/4	3-1/4	1/2	1	1/2	2-1/4	2-1/2	—	430	11,600	1.4 - 3.7
2525	3-3/8	2-1/2	3-1/4	1/2	1	3/4	2-1/4	2-1/2	—	430	11,300	2.0 - 4.9
3020	4-1/4	2	4	5/8	1-1/4	15/16	2-3/4	3	—	800	24,000	3.5 - 6.5
3030	4-1/4	3	4	5/8	1-1/4	15/16	2-3/4	3	—	800	24,000	6.4 - 10.0
3535	5	3-1/2	4.83	1/2	1-1/2	1-3/16	3-1/4	3-1/2	39°	1,000	44,800	10.0 - 15.2
4040	5-3/4	4	5.54	5/8	1-3/4	1-7/16	3-5/8	4	40°	1,700	77,300	19.5 - 24.0
4545	6-3/8	4-1/2	6.13	3/4	2	1-15/16	4-1/4	4-1/2	40°	2,450	110,000	12.5 - 29.9
5050	7	5	6.72	7/8	2-1/4	2-5/16	4-1/2	5	37°	3,100	126,000	20.9 - 39.0

*All shallow keyway bushings are finished with a shallow key.