

D80 Sprockets

1" Pitch

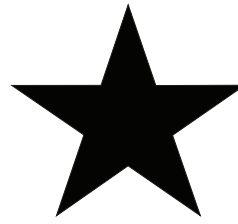

BLACKSTAR®

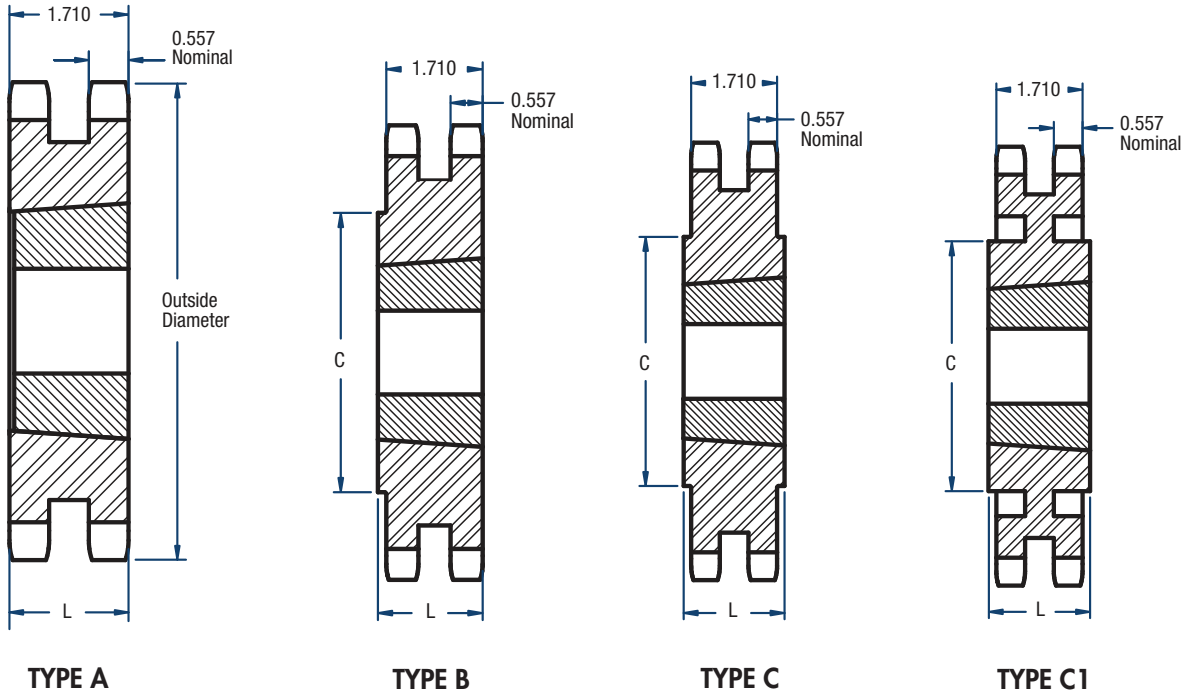

Double- TL Style

No. of Teeth	Catalog Number	Bushing	Diameters (in)		Type	Max. Bore	Dimensions (in)		Approx. Weight (lbs)	
			Outside	Pitch			L	C	Bushing Only	Sprocket Only
13	D80ATL13H	1615	4.66	4.179	A	1-5/8	1-1/2	—	0.9	3.4
14	D80ATL14H	2012	4.98	4.494	A	2	1-1/4	—	1.4	3.5
15	D80ATL15H	2012	5.30	4.810	A	2	1-1/4	—	1.4	4.3
16	D80ATL16H	2517	5.63	5.126	A	2-1/2	1-3/4	3-1/8	3.0	3.8
17	D80ATL17H	2517	5.95	5.442	A	2-1/2	1-3/4	3-1/8	3.0	5.1
18	D80ATL18H	2517	6.27	5.759	A	2-1/2	1-3/4	3-1/8	3.0	6.4
19	D80BTL19H	3020	6.59	6.076	B	3	2	5	5.4	5.6
20	D80BTL20H	3020	6.91	6.392	B	3	2	5-1/4	5.4	7.1
21	D80BTL21H	3020	7.24	6.710	B	3	2	5-9/16	5.4	8.9
25	D80BTL25H	3020	8.52	7.979	B	3	2	6-7/8	5.4	16.5
30	D80CTL30H	3020	10.11	9.567	C	3	2	5-1/4	5.4	25.1
36	D80CTL36	3020	12.03	11.474	C	3	2	5-1/4	5.4	39.4
42	D80CTL42	3020	13.94	13.382	C	3	2	5-1/4	5.4	36.4
45	D80CTL45	3020	14.90	14.336	C1	3	2	5-1/4	5.4	41.4
52	D80CTL52	3020	17.13	16.562	C1	3	2	5-1/4	5.4	56.2
60	D80CTL60	3020	19.68	19.107	C1	3	2	5-1/4	5.4	66.3
68	D80CTL68	3020	22.23	21.653	C1	3	2	5-1/4	5.4	72.0
76	D80CTL76	3020	24.78	24.198	C1	3	2	5-1/4	5.4	89.1
95	D80CTL95	3020	30.83	30.245	C1	3	2	5-1/4	5.4	112.0

Sprockets with "H" suffix have hardened teeth.

NOTE: Maximum bores shown will accommodate a standard keyseat and a setscrew over the keyseat. Slightly larger bores are possible with no keyseat, a shallow keyseat, or a setscrew at an angle to the keyseat.