

# Bushings

## QD STYLE

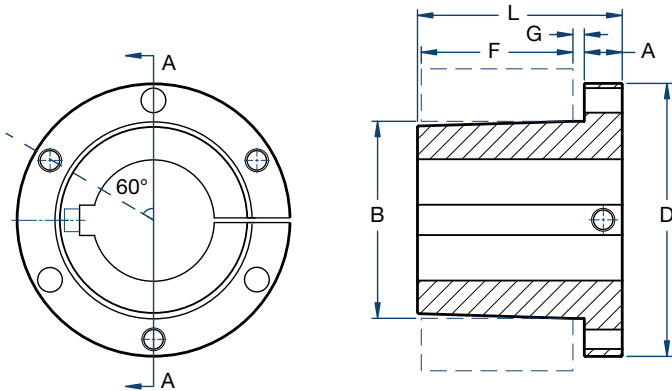

JA to J

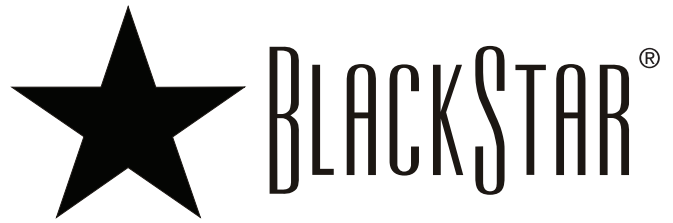
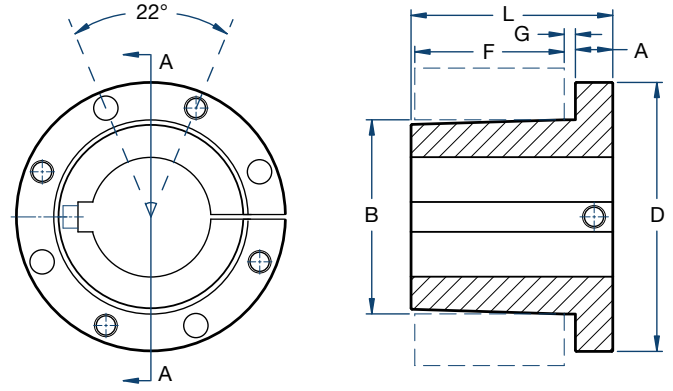

M to W

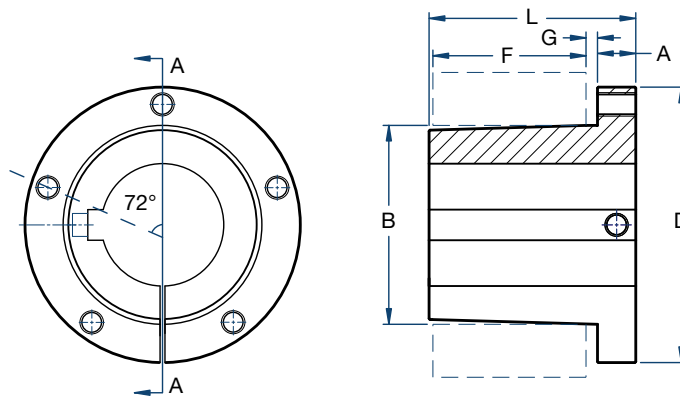

S

Bushing Type	Dimensions (in)							Bolt Circle (in)	Stock Bore Range (in)			Cap Screws Included			Set Screw Size	Wrench-Torque (in-lbs)	Approx. Weight (lbs)	
	A	B	D	E	F	G	L		Min.	Max.		No.	Thread	Length (in)				
										Standard Keyway	Shallow Keyway							No Keyway
JA	3/8	1.375	2	11/16	9/16	1/8	1-1/16	1-21/32	3/8	1	1-3/16	1-1/4	3	10-24	1	10-24	60	0.9
SH	7/16	1.871	2-11/16	7/8	13/16	3/16	1-5/16	2-1/4	1/2	1-3/8	1-5/8	1-11/16	3	1/4-20	1-3/8	1/4	108	1.0
SDS	1/2	2.187	3-3/16	7/8	3/4	3/16	1-3/8	2-11/16	1/2	1-11/16	1-15/16	2	3	1/4-20	1-3/8	1/4	108	1.0
SD	1/2	2.187	3-3/16	1-5/16	1-1/4	3/16	1-13/16	2-11/16	1/2	1-11/16	1-15/16	2	3	1/4-20	1-7/8	1/4	108	1.5
SK	9/16	2.812	3-7/8	1-3/8	1-1/4	3/16	1-15/16	3-5/16	1/2	2-1/8	2-1/2	2-5/8	3	5/16-18	2	5/16	180	2.0
SF	9/16	3.125	4-5/8	1-1/2	1-1/4	1/4	2-1/16	3-7/8	1/2	2-1/4	2-15/16	—	3	3/8-16	2	5/16	360	3.0
E	3/4	3.834	6	1-7/8	1-5/8	5/16	2-5/8	5	7/8	2-7/8	3-1/2	—	3	1/2-13	2-3/4	3/8	720	10.0
F	13/16	4.437	6-5/8	2-13/16	2-1/2	3/8	3-5/8	5-5/8	1	3-5/16	3-15/16	4	3	9/16-12	3-5/8	1/2	900	11.5
J	1	5.148	7-1/4	3-1/2	3-3/16	3/8	4-1/2	6-1/4	1-7/16	3-3/4	4-1/2	—	3	5/8-11	4-1/2	5/8	1,620	18.0
M	1-1/4	6.500	9	5-1/2	5-3/16	3/8	6-3/4	7-7/8	1-15/16	4-3/4	5-1/2	—	4	3/4-10	6-3/4	3/4	2,700	37.0
N	1-1/2	7.000	10	6-5/8	6-1/4	7/16	8-1/8	8-1/2	2-7/16	5	6	—	4	7/8-9	8-1/2	3/4	3,600	57.0
P	1-3/4	8.250	11-3/4	7-5/8	7-1/4	1/2	9-3/8	10	2-15/16	5-15/16	7	—	4	1-8	9-1/2	7/8	5,400	120.0
W	2	10.437	15	9-3/8	9	1/2	11-3/8	12-3/4	4	7-1/2	8-1/2	—	4	1-1/8-11.5	11-1/2	1	7,200	250.0
S	3-1/4	12.125	17-3/4	12-1/2	12	1/2	15-3/4	15	6	8-1/4	10	—	5	1-1/4-15.5	15-1/2	1-1/4	9,000	400.0

Bushings are made of cast iron, steel bushings are available upon request, marked with a "STL" suffix.