

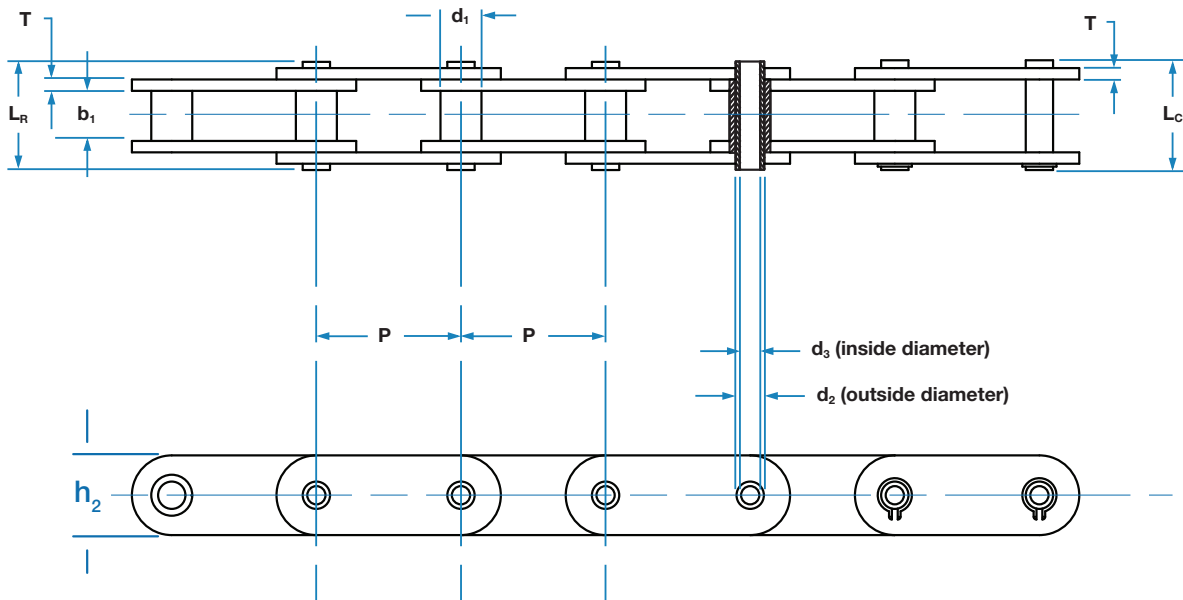

Double-Pitch Roller Chains

Hollow Pin- Small Roller Series

(All dimensions listed in inches)



| Chain Number | Pitch | Roller Diameter | Width Between Inner Plates | Hollow Pin Outside Diameter | Hollow Pin Inside Diameter | Pin Length | | Inner Plate Height | Plate Thickness | Minimum Ultimate Tensile Strength (lbs) | Average Tensile Strength (lbs) | Max Working Load (lbs) | Weight per Foot (lbs/ft) |
|--------------|-------|--------------------|----------------------------|-----------------------------|----------------------------|--------------------|--------------------|--------------------|-----------------|---|--------------------------------|------------------------|--------------------------|
| | P | d ₁ max | b ₁ min | d ₂ max | d ₃ max | L _r max | L _c max | h ₂ max | T | | | | |
| C2040 HP | 1.000 | 0.312 | 0.309 | 0.222 | 0.157 | 0.65 | 0.69 | 0.472 | 0.060 | 2,500 | 2,833 | 464 | 0.3 |
| C2050 HP | 1.250 | 0.400 | 0.370 | 0.284 | 0.201 | 0.81 | 0.86 | 0.591 | 0.080 | 4,636 | 5,126 | 546 | 0.5 |
| C2060 HP | 1.500 | 0.469 | 0.500 | 0.327 | 0.236 | 1.02 | 1.06 | 0.669 | 0.094 | 5,455 | 6,092 | 1,136 | 0.7 |