

TERM. END

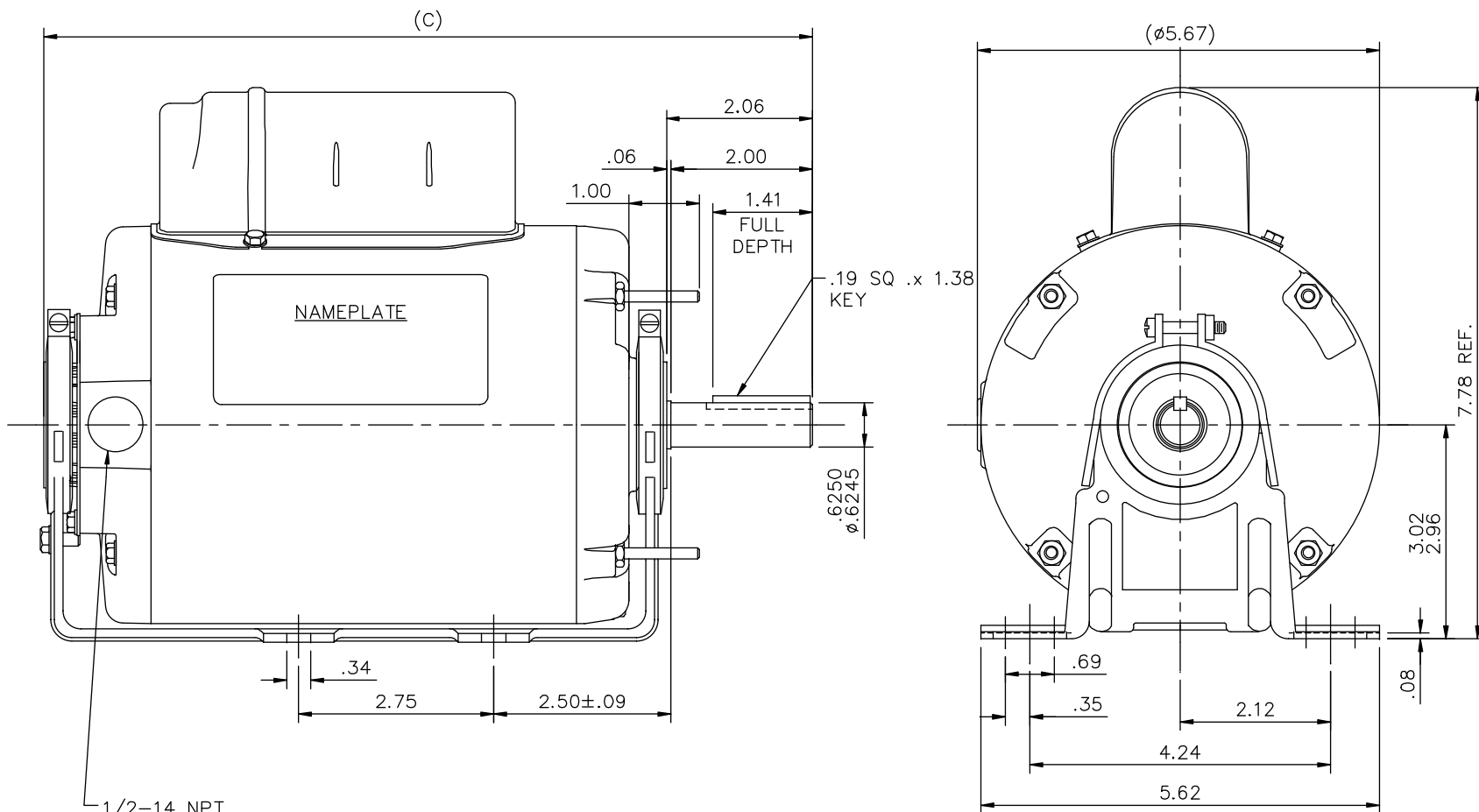

1/2-14 NPT  
CONDUIT HOLE (PLUGGED)

| DASH NO. | "C"   |
|----------|-------|
| 550      | 10.31 |
| 600      | 10.81 |
| 650      | 11.31 |
| 700      | 11.81 |

TOLERANCES  
UNLESS SPECIFIED

| DEC.  | INCHES |
|-------|--------|
| .X    | ±.1    |
| .XX   | ±.03   |
| .XXX  | ±.005  |
| .XXXX | ±.0005 |
| ANG   | ±1/2'  |



ELECTRIC MOTORS  
GEARMOTORS  
AND DRIVES

|       |                |
|-------|----------------|
| DRAWN | PST 07/12/2013 |
| CHK   | SM 07/12/2013  |
| APPD  |                |
| SCALE | 1:1            |
| REF   | 031775         |
| FMF   | A099836.00     |
| PREV  |                |

TITLE  
OUTLINE - 48 FRAME  
RESILIENT MOUNT - TENV

MAT'L.  
1 PHASE

| NO. | REVISION | BY & DATE | CHK  | ANG | FINISH   |
|-----|----------|-----------|------|-----|----------|
|     |          |           | RFP  |     | CAD FILE |
|     |          |           | DIST |     |          |

THIS DRAWING IN DESIGN AND DETAIL IS OUR PROPERTY AND MUST NOT BE USED EXCEPT IN CONNECTION WITH OUR WORK ALL RIGHTS OF DESIGN AND INVENTION ARE RESERVED THIS IS AN ELECTRONICALLY GENERATED DOCUMENT - DO NOT SCALE THIS PRINT

CAD FILE SS404025

SIZE  
A

DRAWING NO.  
SS404025

REV.