

BALDOR® • RELIANCE 

Product Information Packet

CDX7200

2HP,1750RPM,DC,184C,X3646D,XPFC,F1

Part Detail							
Revision:	AK	Status:	PRD/A	Change #:		Proprietary:	No
Type:	DC	Prod. Type:	3646D	Elec. Spec:	36WGZ105	CD Diagram:	CD0860C01
Enclosure:	XPFC	Mfg Plant:		Mech. Spec:	36-4687	Layout:	36LY4687
Frame:	182C	Mounting:	F1	Poles:	00	Created Date:	
Base:	RG	Rotation:	R	Insulation:	A	Eff. Date:	03-20-2017
Field Type:	Shunt	Literature:		Elec. Diagram:		Replaced By:	

Specs			
Enclosure:	XPFC		
Frame:	184C		
Frame Material:	Steel		
XP Class and Group:	CLI GP D; CLII GP F,G		
Agency Approvals:	CSA		
	UL		
	UR		
Base Indicator:	Rigid		
Bearing Grease Type:	Polyrex EM (-20F +300F)		
Drip Cover:	No Drip Cover		
Duty Rating:	CONT		
Feedback Device:	NO FEEDBACK		
Field Winding Type:	SHUNT		
Heater Indicator:	No Heater		
Insulation Class:	A		
Lifting Lugs:	No Lifting Lugs		

Motor Lead Quantity/Wire Size:	2 @ 12 AWG		
	4 @ 18 AWG		
Motor Lead Exit:	Ko Box		
Motor Lead Termination:	Flying Leads		
Mounting Arrangement:	F1		
Product Family:	General Purpose		
Pulley End Bearing Type:	Sealed Bearing		
Shaft Extension Location:	Pulley End		
Shaft Ground Indicator:	No Shaft Grounding		
Shaft Rotation:	Reversible		
Shaft Slinger Indicator:	No Slinger		
Motor Standards:	NEMA		
XP Division:	Division I		
XP Temp Code:	T3B		

Nameplate NP0727XPSL	
NO.	
SER.	
SPEC.	36-4687Z105
CAT.NO.	CDX7200
HP	2
RPM	1750
FRAME	184C
ARM V	180
FLD V	200/100
INSUL	A
DUTY	CONT
BRG/DE	BG6206
BRUSHES	2/BP5125A01
BLANK	
	T. CODE T3B
	ENCL XPFC
	TYPE 3646D
	ARM A 9.5
	FLD A .4/.8
	AMB. 40
	SUPPLY K
	BRG/ODE BG6205

Parts List		
Part Number	Description	Quantity
SA006640	SA 36-4687Z105	1.000 EA
AA003274	AA 36-4687Z105	1.000 EA
35CB3001A02SP	EXPL PROOF CONDUIT BOX, 3/4"PIPE TAP LEA	1.000 EA
11XW1032G06	10-32 X .38, TAPTITE II, HEX WSHR SLTD U	1.000 EA
HW3001B01	BRASS CUP WASHER, FOR #10 SCREW	1.000 EA
36EP1707A01	ENDPLATE, MACH	1.000 EA
HW5100A05	WVY WSHR F/205 & 304 BRGS	1.000 EA
36EP1710A01	ENDPLATE, MACH	1.000 EA
HA3054A01	HEX BOLT 1/4-20 X 1.500 F/S IND.	2.000 EA
10XN2520A16	1/4-20 X 1 HEX HEAD CAP SCR, ZINC PLATED	2.000 EA
HW1000A25	1/4 SAE FLAT WASHER (FS)	4.000 EA
HW1001A25	LOCKWASHER 1/4, ZINC PLT .493 OD, .255 I	2.000 EA
51XN0832A16	8-32 X 1.00 HEX SLOT WSHR HD MACH SCREW	4.000 EA
XY3816A12	3/8-16 FINISHED NUT	4.000 EA
36FN3000A01SP	EXFN, PLASTIC, 7.00 OD, .912 ID	1.000 EA
51XN1032A20	10-32 X 1 1/4 HX WS SL SR	1.000 EA
XY1032A02	10-32 HEX NUT DIRECTIONAL SERRATION	1.000 EA
36FH4009A05SP	IEC FH,GREASER & 1.38 SHAFT HOLE,W/	1.000 EA
51XW1032A06	10-32 X .38, TAPTITE II, HEX WSHR SLTD S	3.000 EA
HW4030A01	1-1/2" N.P.T. PIPE PLUG W/SQ.HEAD	2.000 EA
35CB3500A01SP	CONDUIT BOX LID, MACH	1.000 EA
51XN2520A16	SCREW, HEX WS SLT, ZN, 1/4-20 X 1.00	4.000 EA
HW2501D13	KEY, 3/16 SQ X 1.375	1.000 EA
HA7000A01	KEY RETAINER 7/8" DIA SHAFT	1.000 EA

Parts List (continued)		
Part Number	Description	Quantity
NP0018W	ALUM UL XP CONDUIT BOX NAMEPLATE	1.000 EA
MG1025G29	WILKOFASST, 789.229, DARK CHARCOAL GRAY	0.014 GA
LB1161	LABEL,THERMOSTAT (ROLL LABEL)	1.000 EA
85XU0407S04	4X1/4 U DRIVE PIN STAINLESS	6.000 EA
MJ5000A01	SEALANT, CHICO A COMPOUND	0.050 LB
36RK5003A01	ROCKERARM ASSY	1.000 EA
HA3105A18	THRUBOLT- 3/8-16 X 13.375 X	4.000 EA
LB1119N	WARNING LABEL	1.000 EA
LC0860	CONN. DIAGRAM-DC(SHUNT WOUND MOTOR)	1.000 EA
NP0727XPSL	SS XP DC UL CSA CC CL-I GP-D CL-II GP-F&	1.000 EA
07PA1005	PKG GRP, PRINT PK1156A06	1.000 EA

DC Motor Performance Data

Record # 2509 - Typical performance - not guaranteed values

Winding: 36WGZ105-R008	Type: 3646D	Enclosure: XPFC
-------------------------------	--------------------	------------------------

Nameplate Data		General Characteristics	
Rated Output (HP)	2	Armature Resistance @ 25°C	0.631 Ω
R.P.M.	1750	Commutating Winding Resistance @ 25°C	0.451 Ω
Armature Volts	180		
Armature Amps	9.5	Shunt Winding Resistance @ 25°C	428 Ω
Field Volts	200 / 100		
Field Amps	0.4 / 0.8	Armature Inertia	38.7702 LI ²
Rating - Duty	40C AMB-CONT		
Power Supply Code	K		

Load Characteristics at 180 Armature Volts, 200 Field Volts, 0.42 Field Amps

Load Point	1	2	3	4	5	6	7
Armature Amps	0.6	2.7	4.6	6.5	8.75	10.8	13
R.P.M.	1683	1669	1647	1637	1615	1602	1588
Torque (LB-FT)	0	1.5	3	4.5	6	7.5	9

Performance Graph at 180.0 Arm V, 2.0HP Typical performance - Not guaranteed values

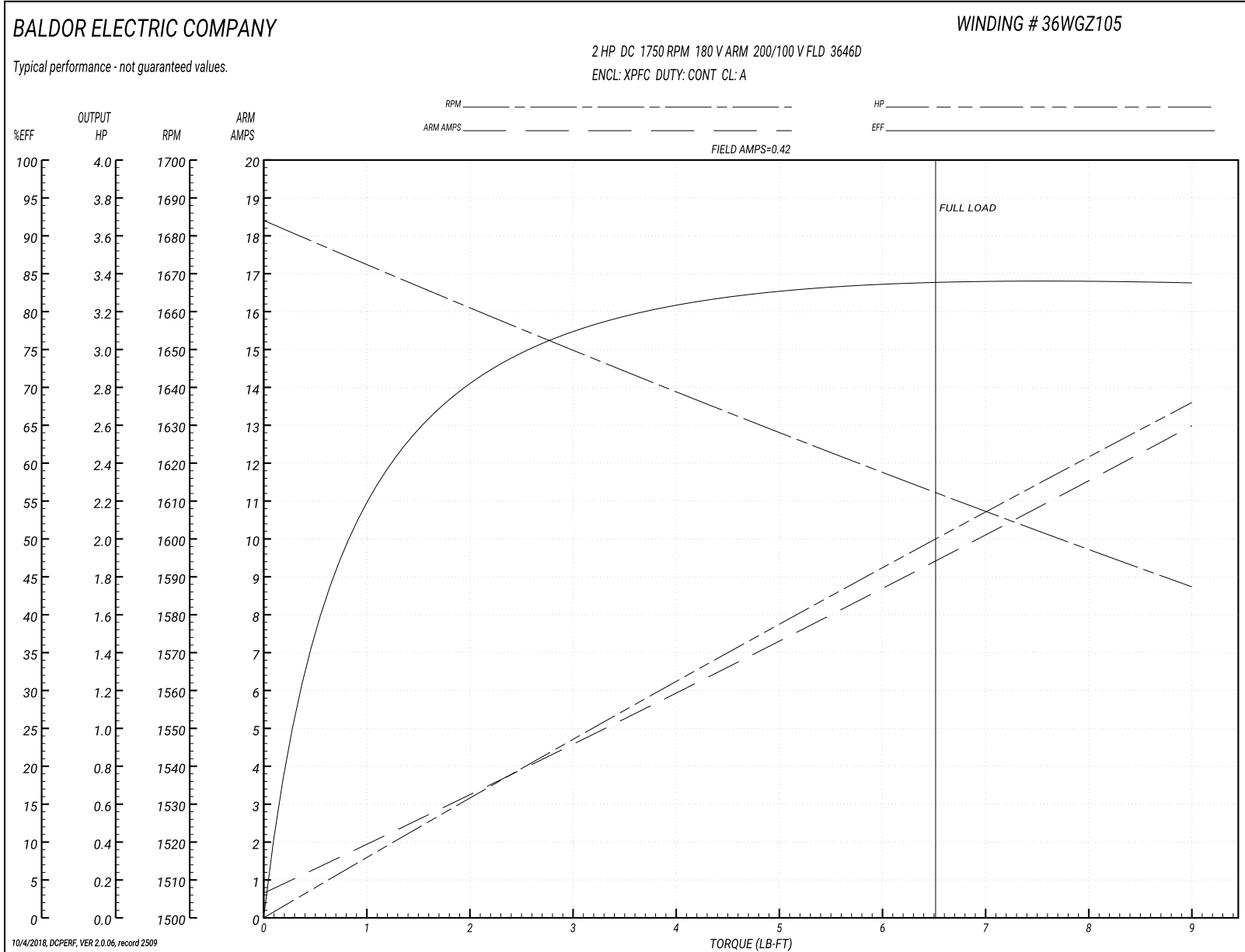

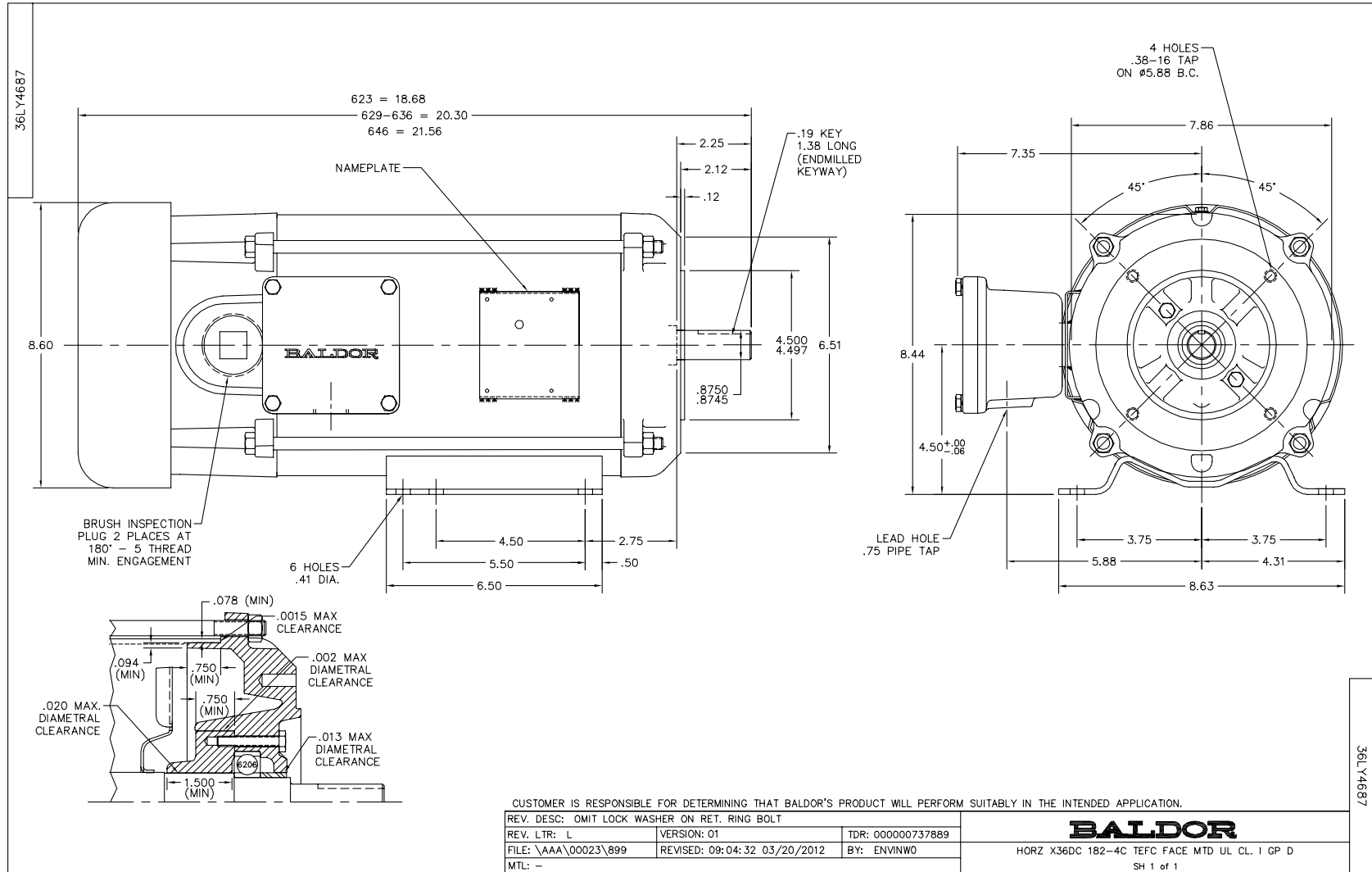

CD0860C01

SHUNT WOUND

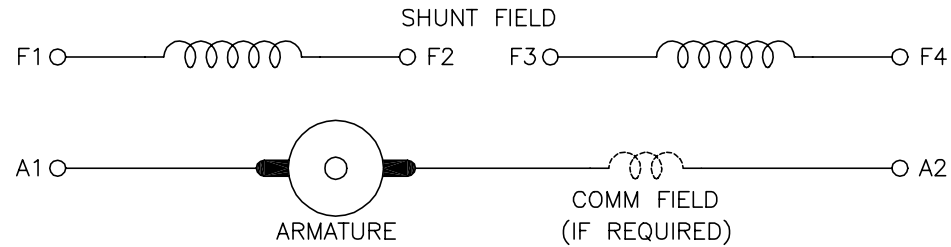

CONNECTION	DIRECTION OF ROTATION			
	CWDE		CCWDE	
	POS TERM (+)	NEG TERM (-)	POS TERM (+)	NEG TERM (-)
HIGH VOLTAGE	A1 F1 CONNECT F2 & F3	A2 F4	A2 F1 CONNECT F2 & F3	A1 F4
LOW VOLTAGE	A1 F1 & F3	A2 F2 & F4	A2 F1 & F3	A1 F2 & F4

NOTES:

1. LIMIT STARTING INRUSH CURRENT TO NOT MORE THAN 3 TIMES RATED AMPERES BY ENERGIZING THE FULL SHUNT FIELD BEFORE BRINGING THE ARMATURE VOLTAGE UP SLOWLY OR IN STEPS.
2. OPTIONAL FIELD REOSTAT MAY BE CONNECTED IN SERIES WITH THE SHUNT FIELD.
3. OPTIONAL THERMOSTAT LEADS ARE MARKED J,J.

REV. DESC: NEW, REPLACE CD0860			
REV. LTR: -	BY: JLP	REVISED: 15:35:22 11/03/2004	TDR: 347796
100098000		FILE: AAA00121477	REF: CD0860C01
		MTL: -	

BALDOR ELECTRIC Co.

DC CONNECTION DIAGRAM, SHUNT FIELD, 6 LEAD, DUAL VOLTAGE

CD0860C01