

BALDOR® • RELIANCE 

Product Information Packet

CESSWDM3558T-5

2HP,1750RPM,3PH,60HZ,145TC,3528M,TEFC,F1

Part Detail							
Revision:	B	Status:	PRD/A	Change #:		Proprietary:	No
Type:	AC	Elec. Spec:	35WGL784	CD Diagram:	CD0006	Mfg Plant:	
Mech. Spec:	35VV818	Layout:	35LYVV818	Poles:	04	Created Date:	08-08-2017
Base:	RG	Eff. Date:	09-24-2018	Leads:	3#18		

Specs			
Catalog Number:	CESSWDM3558T-5	KVA Code:	L
Enclosure:	TEFC	Lifting Lugs:	No Lifting Lugs
Frame:	145TC	Locked Bearing Indicator:	Locked Bearing
Frame Material:	Stainless Steel	Motor Lead Quantity/Wire Size:	3 @ 18 AWG
Output @ Frequency:	2.000 HP @ 60 HZ	Motor Lead Exit:	Ko Box
Synchronous Speed @ Frequency:	1800 RPM @ 60 HZ	Motor Lead Termination:	Flying Leads
Voltage @ Frequency:	575.0 V @ 60 HZ	Motor Type:	3528M
XP Class and Group:	None	Mounting Arrangement:	F1
XP Division:	Not Applicable	Power Factor:	75
Agency Approvals:	UR	Product Family:	Wash Down All Stainless Steel
	CSA	Pulley End Bearing Type:	Sealed Bearing
Auxillary Box:	No Auxillary Box	Pulley Face Code:	C-Face
Auxillary Box Lead Termination:	None	Pulley Shaft Indicator:	Standard
Base Indicator:	Rigid	Rodent Screen:	None
Bearing Grease Type:	Polyrex EM (-20F +300F)	RoHS Status:	ROHS COMPLIANT
Blower:	None	Shaft Extension Location:	Pulley End
Current @ Voltage:	2.300 A @ 575.0 V	Shaft Ground Indicator:	No Shaft Grounding
Design Code:	B	Shaft Rotation:	Reversible

Drip Cover:	No Drip Cover	Shaft Slinger Indicator:	No Slinger
Duty Rating:	CONT	Speed Code:	Single Speed
Electrically Isolated Bearing:	Not Electrically Isolated	Motor Standards:	NEMA
Feedback Device:	NO FEEDBACK	Starting Method:	Direct on line
Front Face Code:	Standard	Thermal Device - Bearing:	None
Front Shaft Indicator:	None	Thermal Device - Winding:	None
Heater Indicator:	No Heater	Vibration Sensor Indicator:	No Vibration Sensor
Insulation Class:	H	Winding Thermal 1:	None
Inverter Code:	Inverter Ready	Winding Thermal 2:	None

Nameplate NP1953A05										
CAT.NO.	CESSWDM3558T-5									
SPEC.	35VV818L784G1									
HP	2									
VOLTS	575									
AMP	2.3									
RPM	1750									
FRAME	145TC				HZ	60			PH	3
SER.F.	1.15		CODE	L	DES	B		CLASS	H	
NEMA-NOM-EFF	86.5			PF	75					
RATING	40C AMB-CONT									
CC	010A				USABLE AT 208V					
DE	6205			ODE	6203					
ENCL	TEFC		SN							

Parts List		
Part Number	Description	Quantity
SA343027	SA 35VV818L784G1	1.000 EA
RA331472	RA 35VV818L784G1	1.000 EA
35FN3002A05SP	EXFN, PLASTIC, 6.376 OD, .638 ID	1.000 EA
NS2512A01	INSULATOR, CONDUIT BOX X	1.000 EA
35CB5001A17	KOBX KIT, (ALL STAINLESS) W/ .75 NPT	1.000 EA
HA5027A02	HA4054 T-DRAIN X2 BAGGED WITH LABEL	1.000 EA
11XW1032G06	10-32 X .38, TAPTITE II, HEX WSHR SLTD U	1.000 EA
HW3001B01	BRASS CUP WASHER, FOR #10 SCREW	1.000 EA
35FE1913A02	FR ENDPLATE ASSY	1.000 EA
HW4606A01	JM CLIPPER/SEAL (WDE-0667-1064-BH49)	1.000 EA
HW5100A03	WAVY WASHER (W1543-017)	1.000 EA
35PE1914A02	PU EP ASSY. FOR LOCKED BRG	1.000 EA
HW4606A02	JM CLIPPER/SEAL (LWE-0938-1624-AL23)	1.000 EA
12XN1032S22	10-32 X 1 3/8 SLOT HEX, STAINLESS STEEL	2.000 EA
HA1049A01	DUBO LOK WASHER SIZE 10 (NYLON LOCK SEAL	2.000 EA
HA1049A01	DUBO LOK WASHER SIZE 10 (NYLON LOCK SEAL	4.000 EA
51XB1214A16	12-14X1.00 HXWSSLD SERTYB	1.000 EA
35FH4005A39	IEC FH NO GREASER DEBURR/CLEAN - SS	1.000 EA
10XN1032S06	HEX HD CAP SCREW, SS	3.000 EA
HW2502D13	SS KEY, 3/16 SQ X 1.375	1.000 EA
HA7000A01	KEY RETAINER 7/8" DIA SHAFT	1.000 EA
MJ5001A02	732 CL SEALANT 3 OZ DIXIE BEARING 289100	0.001 EA
HW3001B01	BRASS CUP WASHER, FOR #10 SCREW	1.000 EA
MJ1000A02	GREASE, POLYREX EM EXXON (USe 4824-15A)	0.050 LB

Parts List (continued)		
Part Number	Description	Quantity
51XB1214A16	12-14X1.00 HXWSSLD SERTYB	1.000 EA
HA3100S14	THRUBOLT 10X32 X 8.875 302 OR 303 SS	4.000 EA
36PA1000	PKG GRP, PRINT PK1016A06	1.000 EA
MN416A01	TAG-INSTAL-MAINT no wire (1200/bx) 5/18	1.000 EA

AC Induction Motor Performance Data

Record # 71804 - Typical performance - not guaranteed values

Winding: 35WGL784-R001	Type: 3528M	Enclosure: TEFC
-------------------------------	--------------------	------------------------

Nameplate Data				575 V, 60 Hz: Single Voltage Motor	
Rated Output (HP)	2			Full Load Torque	6.02 LB-FT
Volts	575			Start Configuration	direct on line
Full Load Amps	2.3			Breakdown Torque	25.18 LB-FT
R.P.M.	1750			Pull-up Torque	20.49 LB-FT
Hz	60	Phase	3	Locked-rotor Torque	24.29 LB-FT
NEMA Design Code	B	KVA Code	L	Starting Current	19.12 A
Service Factor (S.F.)	1.15			No-load Current	1.39 A
NEMA Nom. Eff.	86.5	Power Factor	75	Line-line Res. @ 25°C	11.5 Ω
Rating - Duty	40C AMB-CONT			Temp. Rise @ Rated Load	56°C
S.F. Amps				Temp. Rise @ S.F. Load	68°C
				Locked-rotor Power Factor	49.3
				Rotor inertia	0.165 LB-FT ²

Load Characteristics 575 V, 60 Hz, 2 HP

% of Rated Load	25	50	75	100	125	150	S.F.
Power Factor	33	53	67	75	80	83	78
Efficiency	77.8	85.3	87	87	86.2	84.8	86.5
Speed	1788	1776	1763	1749	1734	1718	1740
Line amperes	1.47	1.65	1.94	2.3	2.71	3.19	2.55

Performance Graph at 575V, 60Hz, 2.0HP Typical performance - Not guaranteed values

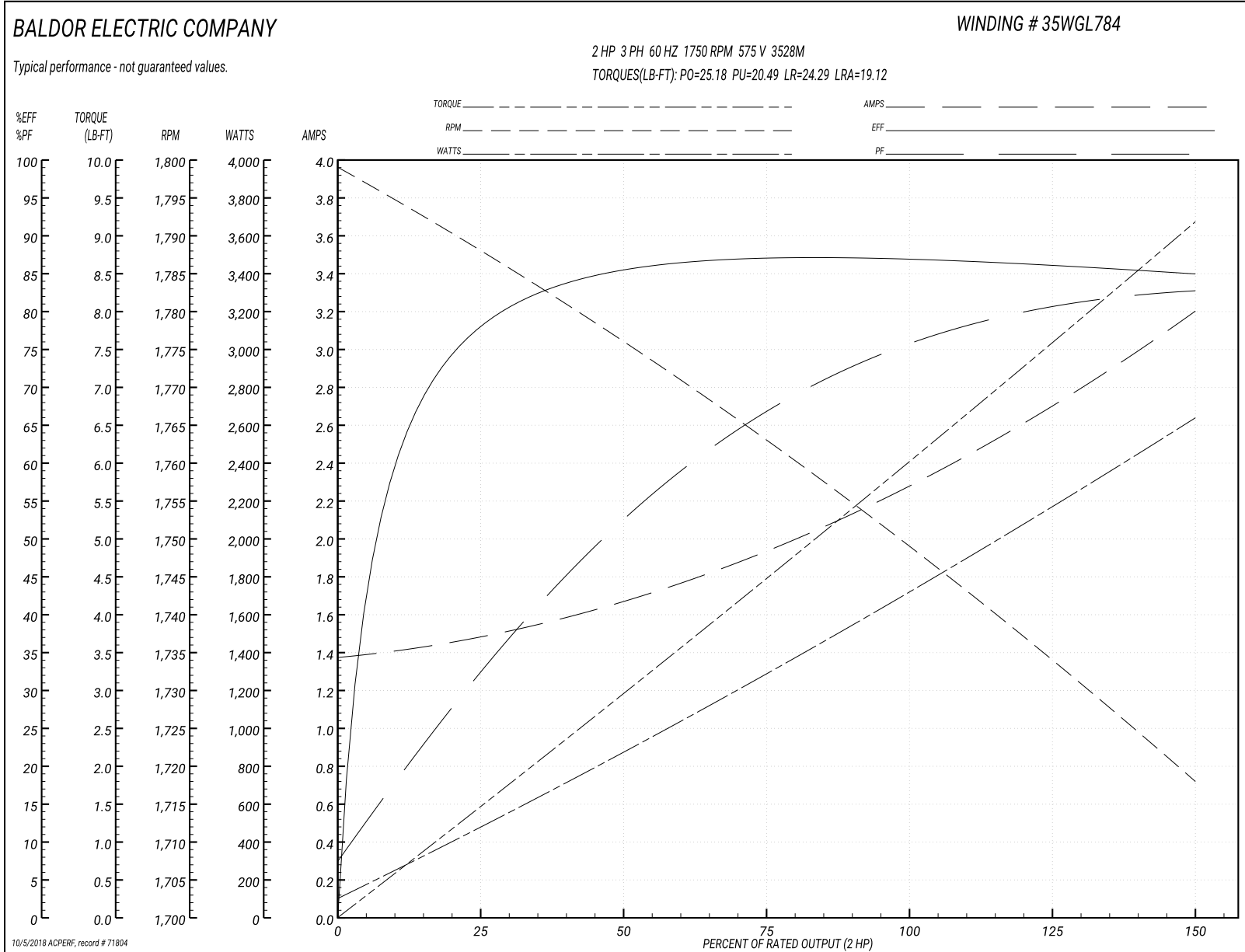

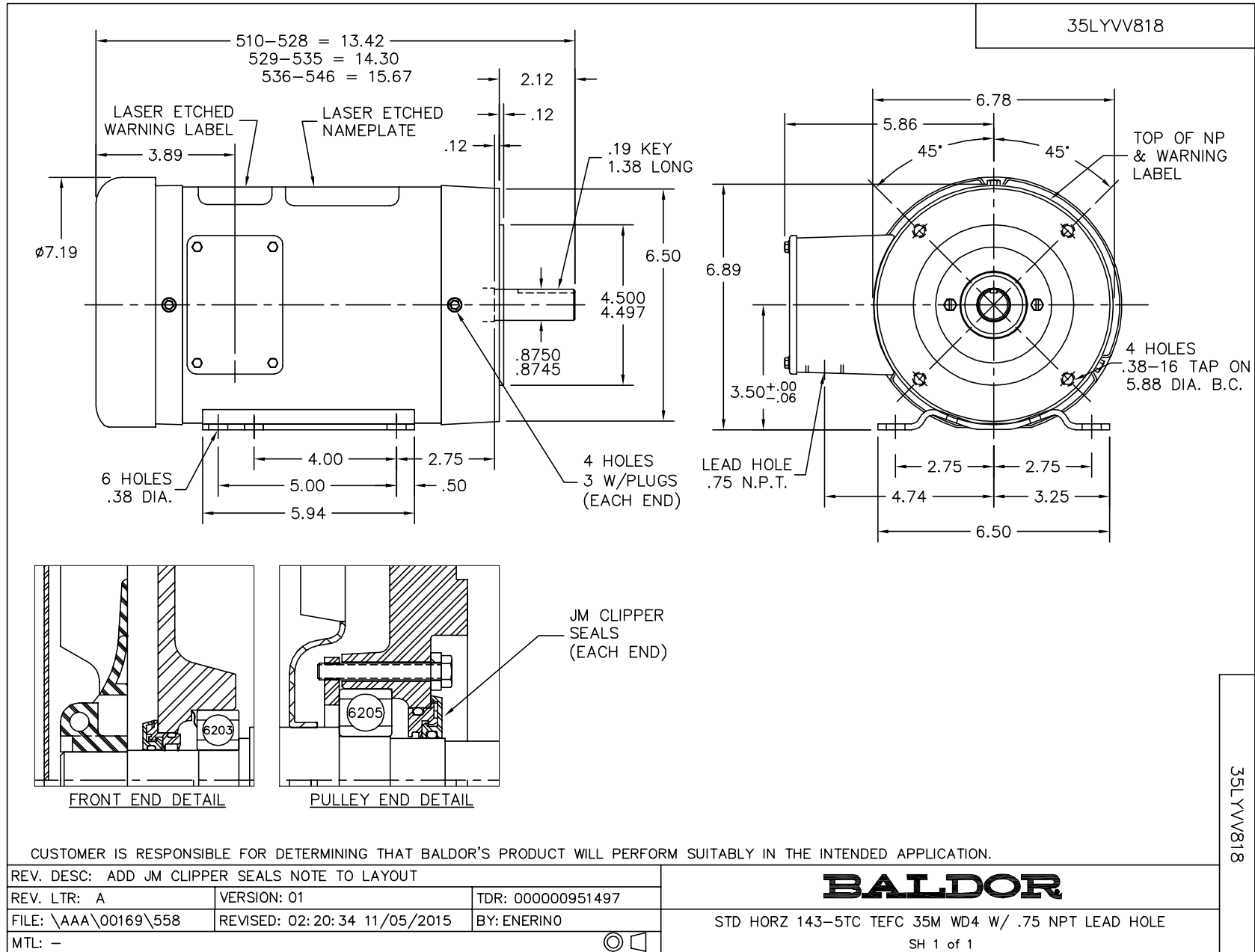

CD0006

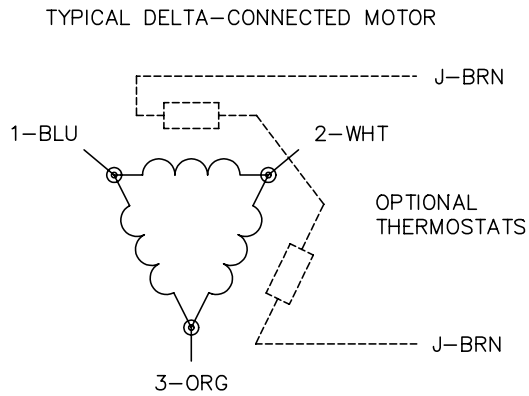
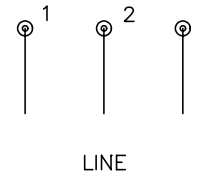
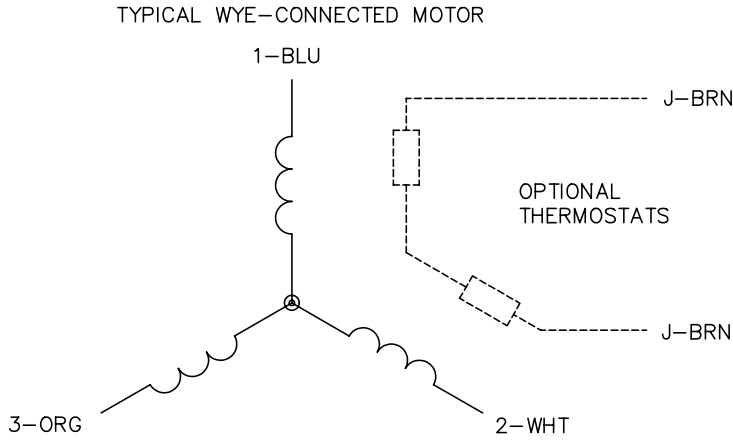

NOTES:

1. THREE LEAD MOTOR MAY BE EITHER WYE CONNECTED OR DELTA CONNECTED.
2. INTERCHANGE ANY TWO LINE LEADS TO REVERSE ROTATION.
3. OPTIONAL THERMOSTATS ARE PROVIDED WHEN SPECIFIED.
4. ACTUAL NUMBER OF INTERNAL PARALLEL CIRCUITS MAY VARY.
5. LEAD COLORS ARE OPTIONAL. LEADS MUST BE NUMBERED AS SHOWN.

REV. DESC: REVISE TO SHOW OPTIONAL COLORS			
REV. LTR: D	BY: JLP	REVISED: 01/21/99 4:02	TDR: 0171435
9000D		FILE: AAA00005141	MDL: -
		MTL: -	

BALDOR ELECTRIC Co.

3PH, SV, 3 LEADS, WYE OR DELTA CONNECTED

CD0006