

BALDOR® • RELIANCE 

Product Information Packet

CHC545A

1HP,1725RPM,1PH,60HZ,56,3528C,TEAO,F1,N

Part Detail							
Revision:	B	Status:	PRD/A	Change #:		Proprietary:	No
Type:	AC	Elec. Spec:	35WGR924	CD Diagram:	CD0381	Mfg Plant:	
Mech. Spec:	35E3460	Layout:	35LYE3460	Poles:	04	Created Date:	03-14-2016
Base:	RS	Eff. Date:	03-21-2017	Leads:	6#18,1#14 #1TH		

Specs			
Catalog Number:	CHC545A	Inverter Code:	Not Inverter
Enclosure:	TEAO	KVA Code:	H
Frame:	56	Lifting Lugs:	No Lifting Lugs
Frame Material:	Steel	Locked Bearing Indicator:	No Locked Bearing
Output @ Frequency:	1.000 HP @ 60 HZ	Motor Lead Quantity/Wire Size:	6 @ 18 AWG
Synchronous Speed @ Frequency:	1800 RPM @ 60 HZ	Motor Lead Exit:	Terminal Panel
Voltage @ Frequency:	115.0 V @ 60 HZ	Motor Lead Termination:	Flying Leads
	230.0 V @ 60 HZ	Motor Type:	3528C
XP Class and Group:	None	Mounting Arrangement:	F1
XP Division:	Not Applicable	Power Factor:	81
Agency Approvals:	UR	Product Family:	General Purpose
	CSA	Pulley End Bearing Type:	Sealed Bearing
Auxillary Box:	No Auxillary Box	Pulley Face Code:	Resilient Mount
Auxillary Box Lead Termination:	None	Pulley Shaft Indicator:	Standard
Base Indicator:	Resilient	Rodent Screen:	None
Bearing Grease Type:	Polyrex EM (-20F +300F)	RoHS Status:	ROHS COMPLIANT
Blower:	None	Shaft Extension Location:	Pulley End
Current @ Voltage:	10.600 A @ 115.0 V	Shaft Ground Indicator:	No Shaft Grounding

	5.300 A @ 230.0 V	Shaft Rotation:	Reversible
Design Code:	-	Shaft Slinger Indicator:	No Slinger
Drip Cover:	No Drip Cover	Speed Code:	Single Speed
Duty Rating:	CONT	Motor Standards:	NEMA
Electrically Isolated Bearing:	Not Electrically Isolated	Starting Method:	Direct on line
Feedback Device:	NO FEEDBACK	Thermal Device - Bearing:	NONE (OLD)
Front Face Code:	Terminal Panel	Thermal Device - Winding:	None
Front Shaft Indicator:	None	Vibration Sensor Indicator:	No Vibration Sensor
Heater Indicator:	No Heater	Winding Thermal 1:	Automatic Thermal Overload
Insulation Class:	F	Winding Thermal 1 Location:	SB
		Winding Thermal 2:	None

Nameplate NP1257L	
CAT.NO.	CHC545A
SPEC.	35E3460R924G1
HP	1 AIR OVER
VOLTS	115/230
AMP	10.6/5.3
RPM	1725
FRAME	56
HZ	60
PH	1
SER.F.	1.00
CODE	H
DES	-
CL	F
NEMA-NOM-EFF	72
PF	81
RATING	40C AMB-CONT
CC	USABLE AT 208V
DE	6203
ODE	6203
ENCL	TEAO
SN	

Parts List		
Part Number	Description	Quantity
SA317049	SA 35E3460R924G1	1.000 EA
RA304644	RA 35E3460R924G1	1.000 EA
OC3050C09	CYL OIL CAP 50MFD/240V	1.000 EA
RM1001A01	GROMMET "MIDSTATES"	1.000 EA
53XT0832G07	8-32X7/16 PN STD SR TY23G X	1.000 EA
LD5000A01	LEAD ASSY, ML1400DF14 7" RING TRM EA END	1.000 EA
51XW1032A06	10-32 X .38, TAPTITE II, HEX WSHR SLTD S	2.000 EA
HW1003A10	WASHER, #10 EX TH LK, ZN X	2.000 EA
35EP3102A01SP	FR ENDPLATE, MACH	1.000 EA
51XW0832A07	8-32 X .44, TAPTITE II, HEX WSHR SLTD SE	3.000 EA
RM1000A02	CUSHION RING, MODEL 35 SAME AS A07	1.000 EA
HA6005A01	CLAMP, BASE	2.000 EA
12XN1032A18	10-32 X 1 1/4 HEX HD SLTD	1.000 EA
XY1032A02	10-32 HEX NUT DIRECTIONAL SERRATION	1.000 EA
35CB4802A02SP	CAPACITOR COVER, STAMPED X	1.000 EA
35GS3001A02	GASKET, CA.COVER, 5.38 LONG .06 CS301	1.000 EA
51XB1016A05	10-16X5/16HX WA SL SR TYB (F/S)	2.000 EA
HW5100A03	WAVY WASHER (W1543-017)	1.000 EA
35EP1101A01	PU ENPLATE, MACH	1.000 EA
RM1000A02	CUSHION RING, MODEL 35 SAME AS A07	1.000 EA
XY1032A02	10-32 HEX NUT DIRECTIONAL SERRATION	4.000 EA
HA6005A01	CLAMP, BASE	2.000 EA
12XN1032A18	10-32 X 1 1/4 HEX HD SLTD	1.000 EA
XY1032A02	10-32 HEX NUT DIRECTIONAL SERRATION	1.000 EA

Parts List (continued)		
Part Number	Description	Quantity
WD4100A01	DP-875 HEYCO PLUG OR 62MP0875 MICRO PLAS	1.000 EA
35CB4500SP	TERMINAL BOX LID STAMPED	1.000 EA
35GS1002	GASKET,1/16 THICK LEXIDE	1.000 EA
51XW0832A07	8-32 X .44, TAPTITE II, HEX WSHR SLTD SE	2.000 EA
HW2501D13	KEY, 3/16 SQ X 1.375	1.000 EA
HA7000A04	KEY RETAINER 0.625 DIA SHAFTS	1.000 EA
85XU0407S04	4X1/4 U DRIVE PIN STAINLESS	2.000 EA
MJ1000A02	GREASE, POLYREX EM EXXON (USe 4824-15A)	0.050 LB
MG1000G27	MED CHARCOAL METALLIC GREY 400-0096	0.017 GA
SP5078	MODEL 35 TERMINAL PANEL HARDWARE ONLY, N	1.000 EA
HA3100A22	THRUBOLT 10-32 X 10.125	4.000 EA
35BA4002B01	RESILIENT BASE, STAMPED	1.000 EA
LB1118	LABEL,WARNING (ROLL LABEL)	1.000 EA
LC0052	CONNECTION LABEL	1.000 EA
NP1257L	ALUM UL CSA CC THERMAL REV MTG	1.000 EA
36PA1000	PKG GRP, PRINT PK1016A06	1.000 EA
MN416A01	TAG-INSTAL-MAINT no wire (1200/bx) 5/18	1.000 EA

No performance data has been
assigned to this product.

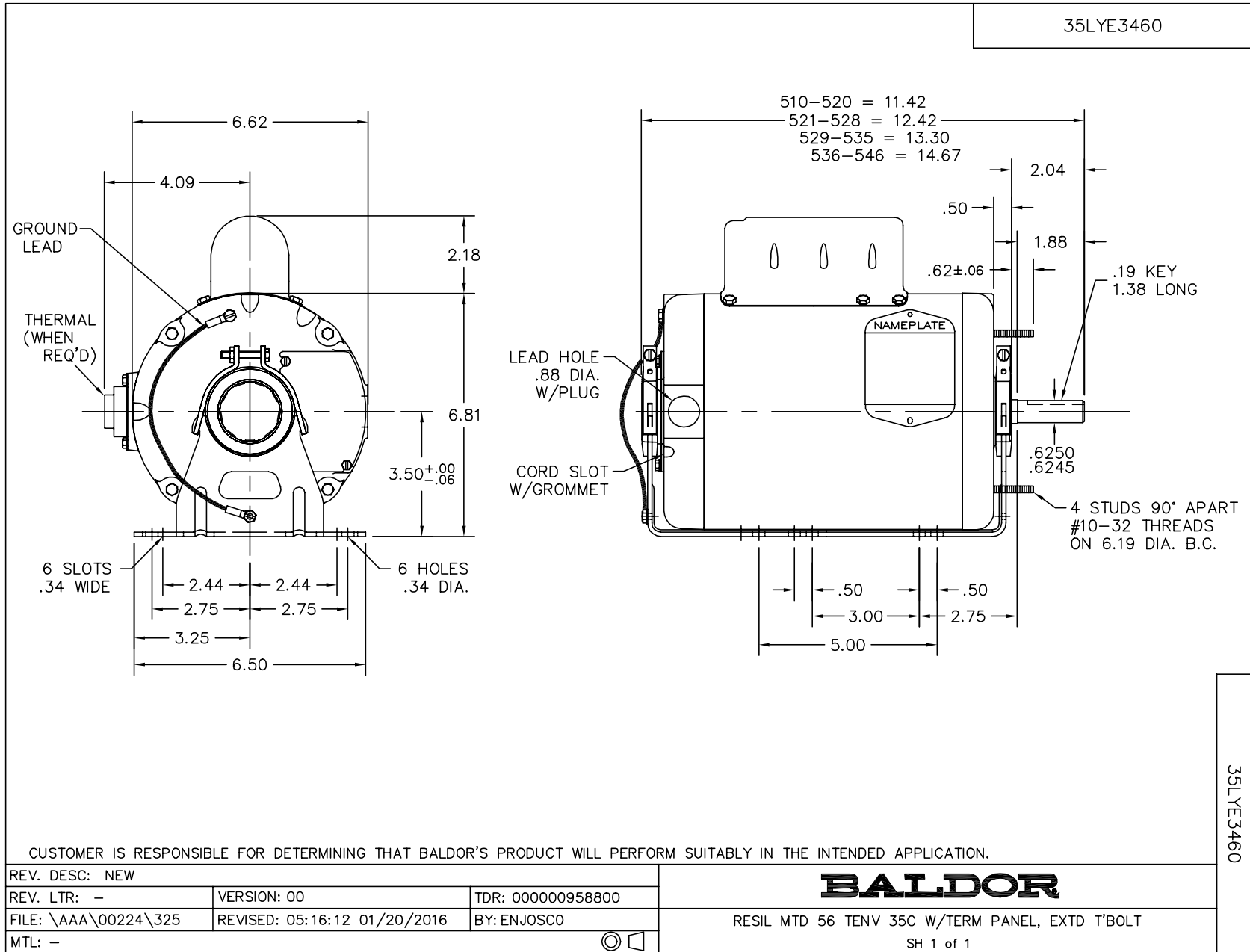

CD0381

