

BALDOR® • RELIANCE 

Product Information Packet

CHM565A

1HP,1140RPM,3PH,60HZ,56,3524M,TEAO,F1,N

Part Detail							
Revision:	E	Status:	PRD/A	Change #:		Proprietary:	No
Type:	AC	Elec. Spec:	35WGL465	CD Diagram:	CD0007	Mfg Plant:	
Mech. Spec:	35X463	Layout:	35LYX463	Poles:	06	Created Date:	12-22-2015
Base:	RS	Eff. Date:	06-08-2018	Leads:	12#18		

Specs			
Catalog Number:	CHM565A	Insulation Class:	F
Enclosure:	TEAO	Inverter Code:	Not Inverter
Frame:	56	KVA Code:	K
Frame Material:	Steel	Lifting Lugs:	No Lifting Lugs
Output @ Frequency:	1.000 HP @ 60 HZ	Locked Bearing Indicator:	No Locked Bearing
Synchronous Speed @ Frequency:	1200 RPM @ 60 HZ	Motor Lead Quantity/Wire Size:	12 @ 18 AWG
Voltage @ Frequency:	208.0 V @ 60 HZ	Motor Lead Exit:	Terminal Panel
	230.0 V @ 60 HZ	Motor Lead Termination:	Flying Leads
	460.0 V @ 60 HZ	Motor Type:	3524M
XP Class and Group:	None	Mounting Arrangement:	F1
XP Division:	Not Applicable	Power Factor:	68
Agency Approvals:	UR	Product Family:	General Purpose
	CSA	Pulley End Bearing Type:	Ball
Auxillary Box:	No Auxillary Box	Pulley Face Code:	Resilient Mount
Auxillary Box Lead Termination:	None	Pulley Shaft Indicator:	Standard
Base Indicator:	Resilient	Rodent Screen:	None
Bearing Grease Type:	Polyrex EM (-20F +300F)	RoHS Status:	ROHS COMPLIANT
Blower:	None	Shaft Extension Location:	Pulley End

Current @ Voltage:	1.800 A @ 460.0 V	Shaft Ground Indicator:	No Shaft Grounding
	3.600 A @ 230.0 V	Shaft Rotation:	Reversible
	3.700 A @ 208.0 V	Shaft Slinger Indicator:	No Slinger
Design Code:	B	Speed Code:	Single Speed
Drip Cover:	No Drip Cover	Motor Standards:	NEMA
Duty Rating:	CONT	Starting Method:	Direct on line
Electrically Isolated Bearing:	Not Electrically Isolated	Thermal Device - Bearing:	NONE (OLD)
Feedback Device:	NO FEEDBACK	Thermal Device - Winding:	None
Front Face Code:	Terminal Panel	Vibration Sensor Indicator:	No Vibration Sensor
Front Shaft Indicator:	None	Winding Thermal 1:	Automatic Thermal Overload
Heater Indicator:	No Heater	Winding Thermal 1 Location:	SB
		Winding Thermal 2:	None

Nameplate NP1257L												
CAT.NO.	CHM565A											
SPEC.	35X463L465G1											
HP	1											
VOLTS	208-230/460											
AMP	3.7-3.6/1.8											
RPM	1140											
FRAME	56					HZ	60			PH	3	
SER.F.	1.15			CODE	K			DES	B		CL	F
NEMA-NOM-EFF	74			PF	68							
RATING	40C AMB-CONT											
CC								USABLE AT 208V				
DE	6203			ODE	6203							
ENCL	TEAO			SN								

Parts List		
Part Number	Description	Quantity
SA320950	SA 35X463L465G1	1.000 EA
RA308694	RA 35X463L465G1	1.000 EA
35CB4500SP	TERMINAL BOX LID STAMPED	1.000 EA
35GS1002	GASKET,1/16 THICK LEXIDE	1.000 EA
51XW0832A07	8-32 X .44, TAPTITE II, HEX WSHR SLTD SE	2.000 EA
11XW0832G06	#8-32 X 3/8, TAPTITE II, HEX WSHR SLTD	1.000 EA
LD5000A01	LEAD ASSY, ML1400DF14 7" RING TRM EA END	1.000 EA
51XW1032A06	10-32 X .38, TAPTITE II, HEX WSHR SLTD S	2.000 EA
HW1003A10	WASHER, #10 EX TH LK, ZN X	2.000 EA
SP1003A01	TERM. BOARD, MODE 35 SW X H-23655	1.000 EA
51XW0832A07	8-32 X .44, TAPTITE II, HEX WSHR SLTD SE	3.000 EA
RM1000A02	CUSHION RING, MODEL 35 SAME AS A07	1.000 EA
HA6005A01	CLAMP, BASE	2.000 EA
12XN1032A18	10-32 X 1 1/4 HEX HD SLTD	1.000 EA
XY1032A02	10-32 HEX NUT DIRECTIONAL SERRATION	1.000 EA
RM1001A01	GROMMET "MIDSTATES"	1.000 EA
HW5100A03	WAVY WASHER (W1543-017)	1.000 EA
35EP3102B30	FR EP, MACH W/.50 STRAIGHT PIPE TAP, DRA	1.000 EA
RM1000A02	CUSHION RING, MODEL 35 SAME AS A07	1.000 EA
HA6005A01	CLAMP, BASE	2.000 EA
12XN1032A18	10-32 X 1 1/4 HEX HD SLTD	1.000 EA
35EP1101A01	PU ENPLATE, MACH	1.000 EA
XY1032A02	10-32 HEX NUT DIRECTIONAL SERRATION	1.000 EA
XY1032A02	10-32 HEX NUT DIRECTIONAL SERRATION	4.000 EA

Parts List (continued)		
Part Number	Description	Quantity
HW2501D13	KEY, 3/16 SQ X 1.375	1.000 EA
HA7000A04	KEY RETAINER 0.625 DIA SHAFTS	1.000 EA
85XU0407S04	4X1/4 U DRIVE PIN STAINLESS	2.000 EA
MJ1000A02	GREASE, POLYREX EM EXXON (USe 4824-15A)	0.050 LB
MG1000G27	MED CHARCOAL METALLIC GREY 400-0096	0.017 GA
35BA4002B01	RESILIENT BASE, STAMPED	1.000 EA
HA3100A18	THRUBOLT 10-32 X 9.250	4.000 EA
LB1118	LABEL,WARNING (ROLL LABEL)	1.000 EA
LC0007	CONNECTION LABEL	1.000 EA
NP1257L	ALUM UL CSA CC THERMAL REV MTG	1.000 EA
35PA1066	PKG GRP, PRINT PK1008A06	1.000 EA
MN416A01	TAG-INSTAL-MAINT no wire (1200/bx) 5/18	1.000 EA

AC Induction Motor Performance Data

Record # 61293 - Typical performance - not guaranteed values

Winding: 35WGL465-R002	Type: 3524M	Enclosure: TEAO
-------------------------------	--------------------	------------------------

Nameplate Data				460 V, 60 Hz: High Voltage Connection	
Rated Output (HP)	1			Full Load Torque	4.47 LB-FT
Volts	208-230/460			Start Configuration	direct on line
Full Load Amps	3.7-3.6/1.8			Breakdown Torque	15.2 LB-FT
R.P.M.	1140			Pull-up Torque	10.1 LB-FT
Hz	60	Phase	3	Locked-rotor Torque	12 LB-FT
NEMA Design Code	B	KVA Code	K	Starting Current	10 A
Service Factor (S.F.)	1.15			No-load Current	1.23 A
NEMA Nom. Eff.	74	Power Factor	68	Line-line Res. @ 25°C	19.8 Ω
Rating - Duty	40C AMB-CONT			Temp. Rise @ Rated Load	32°C
S.F. Amps				Temp. Rise @ S.F. Load	37°C
				Locked-rotor Power Factor	58
				Rotor inertia	0.142 LB-FT ²

Load Characteristics 460 V, 60 Hz, 1 HP

% of Rated Load	25	50	75	100	125	150	S.F.
Power Factor	31	46	57	68	73	78	71
Efficiency	59.2	73	78.6	75.9	75.4	73.4	75.6
Speed	1187	1177	1166	1153	1138	1122	1144
Line amperes	1.29	1.4	1.55	1.78	2.07	2.35	1.95

Performance Graph at 460V, 60Hz, 1.0HP Typical performance - Not guaranteed values

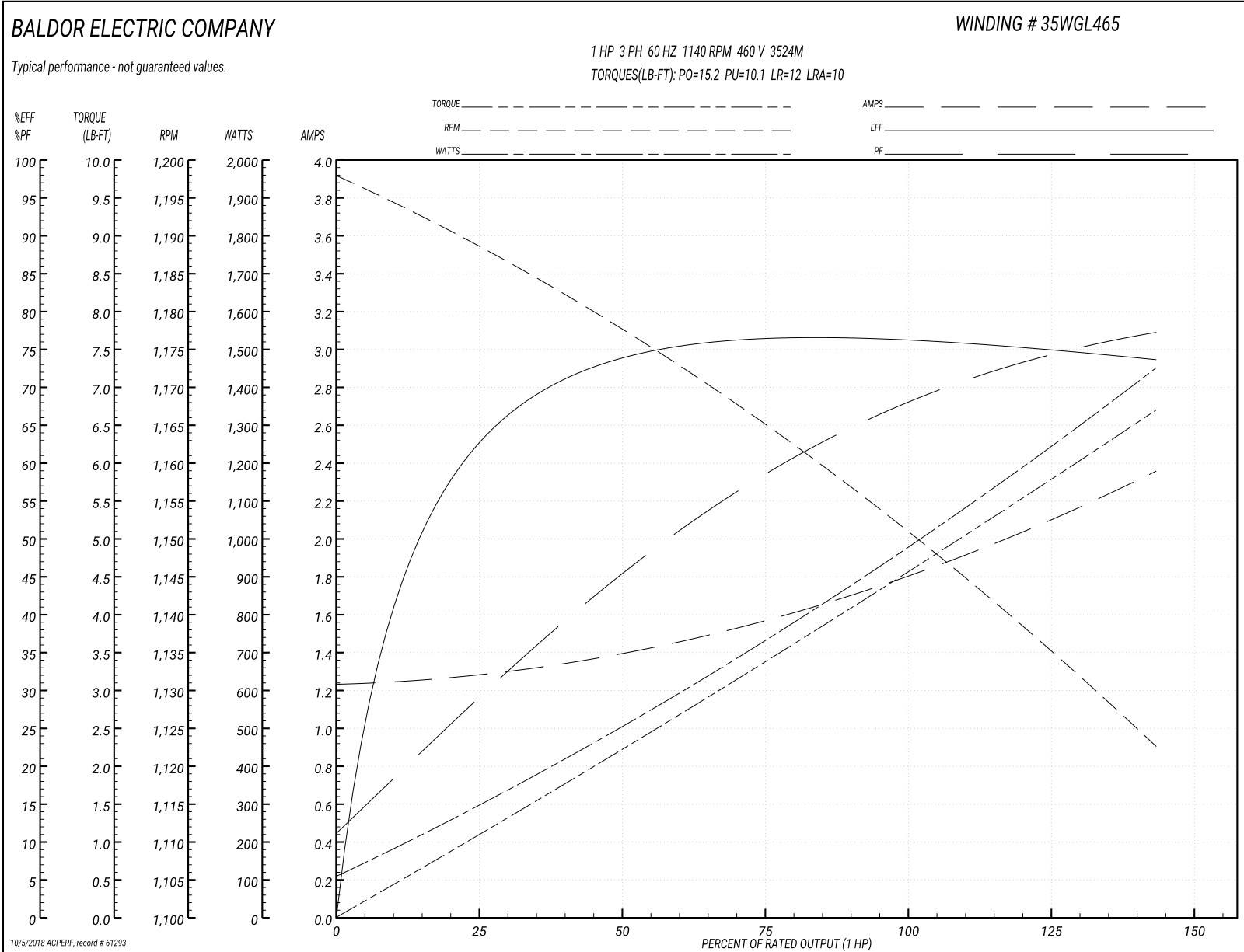

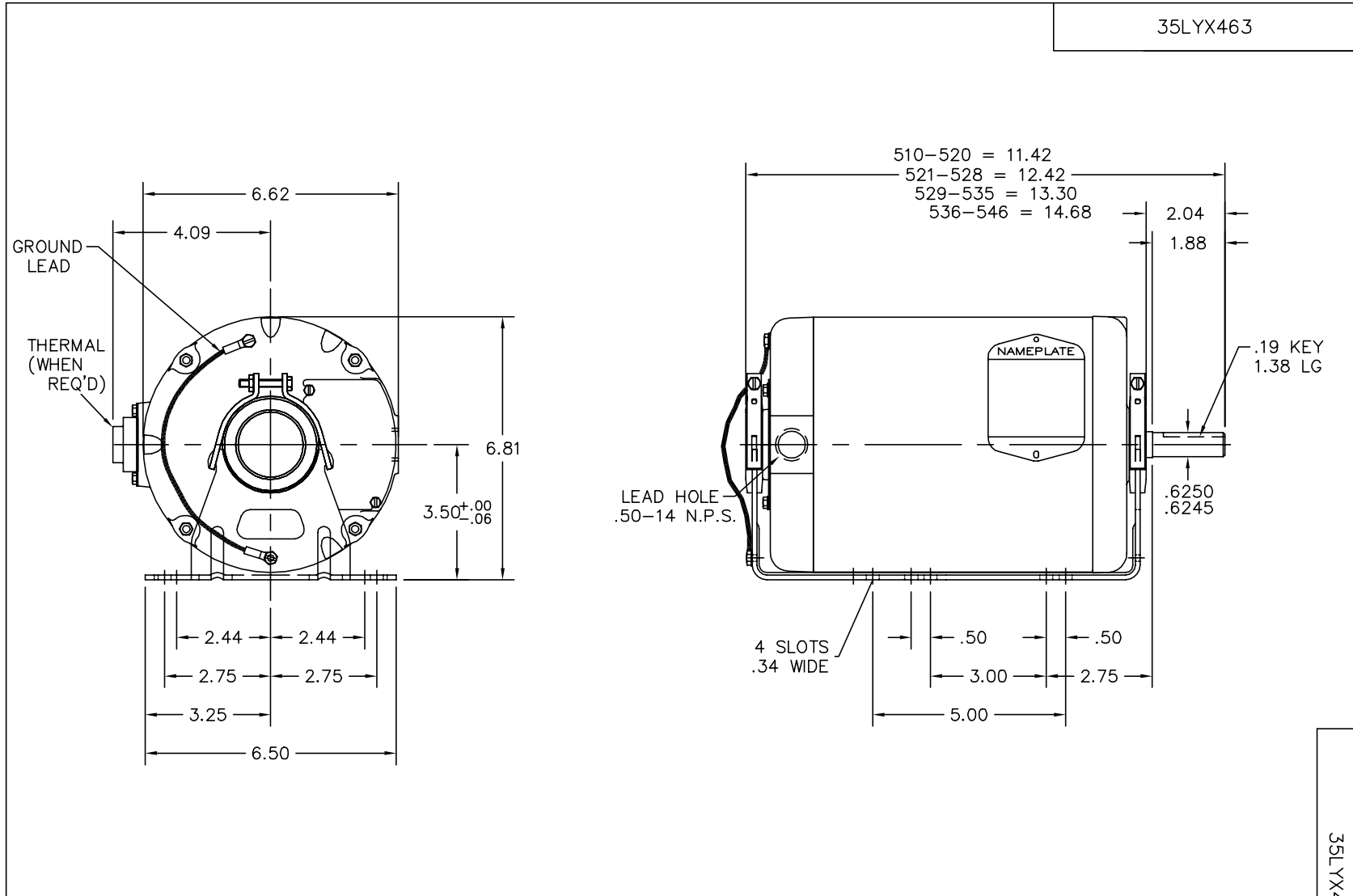

CUSTOMER IS RESPONSIBLE FOR DETERMINING THAT BALDOR'S PRODUCT WILL PERFORM SUITABLY IN THE INTENDED APPLICATION.

REV. DESC: NEW		TDR: 000000465827	
REV. LTR: -	VERSION: 00	REVIS: 10:40:51 06/02/2008	
FILE: \AAA\00156\896		BY: ENTERDO	
MTL: -			

BALDOR • DODGE • RELIANCE

RESIL 56 TEAO 35M W/TERM PANEL .50-14 N.P.S.

SH 1 of 1

35LYX463

CD0007

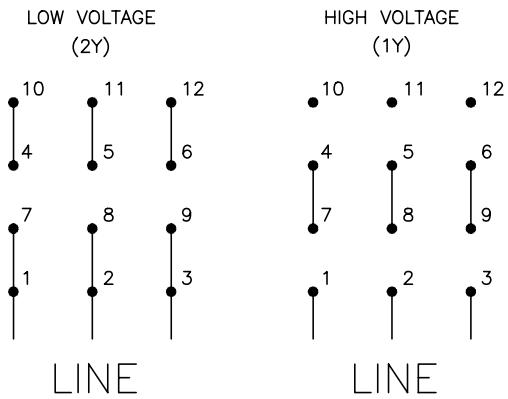
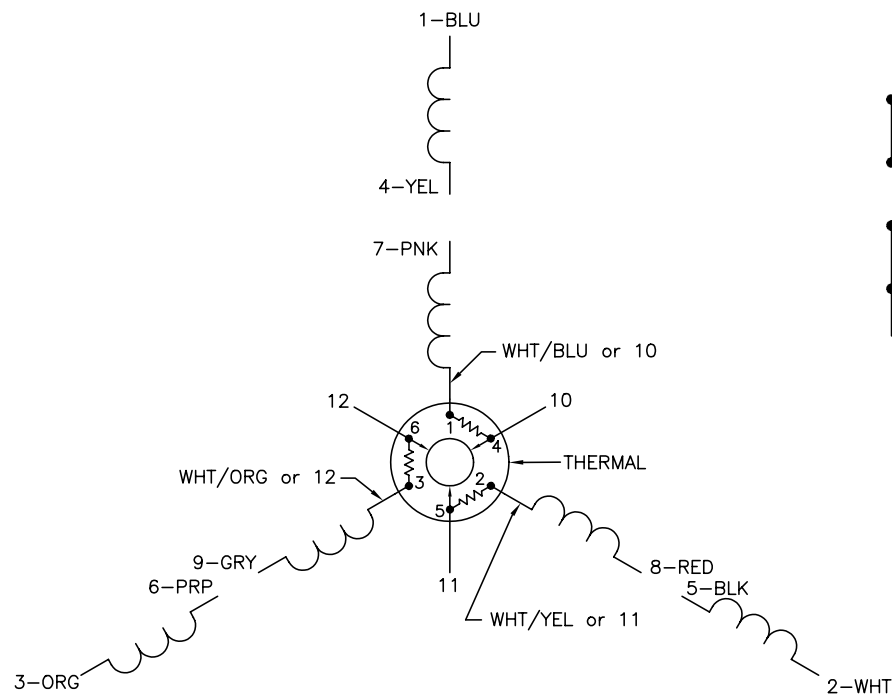

- NOTES:
1. INTERCHANGE ANY TWO LINE LEADS TO REVERSE ROTATION.
 2. ACTUAL NUMBER OF INTERNAL PARALLEL CIRCUITS MAY VARY.
 3. LEAD COLORS ARE OPTIONAL. LEADS MUST ALWAYS BE NUMBERED AS SHOWN.

REV. DESC: ADDED "CK" PLANT CODE			
REV. LTR: E	BY: EAH	REVISED: 05/06/99 17:1	TDR: 0181040
L00000		FILE: AAA00008370	MDL: -
		MTL: -	

BALDOR ELECTRIC Co.

3PH, DV, THERMAL, 12 LEADS

CD0007