

TYPE	OUTPUT	POLE	TIME RATING	VOLTAGE	Hz	SYN.SPEED R.P.M
	HP.					
AECA	200 / 50	4/8	CONT.	460	60	1800/900

TOTALLY ENCLOSED FAN-COOLED TYPE, SQUIRREL-CAGE ROTOR
2 SPEED, 1 WINDING VARIABLE TORQUE

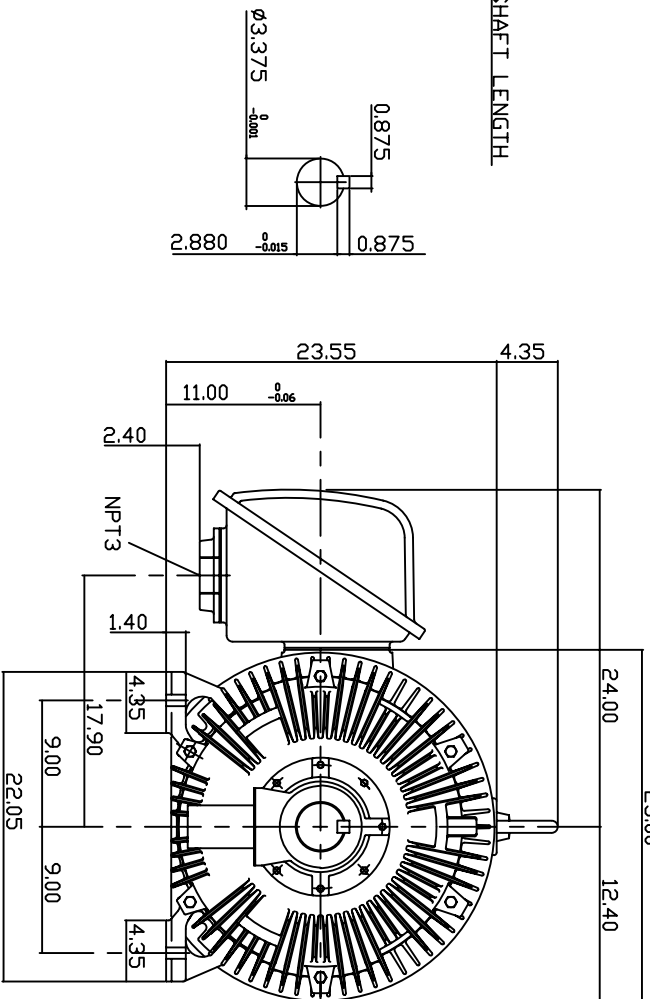
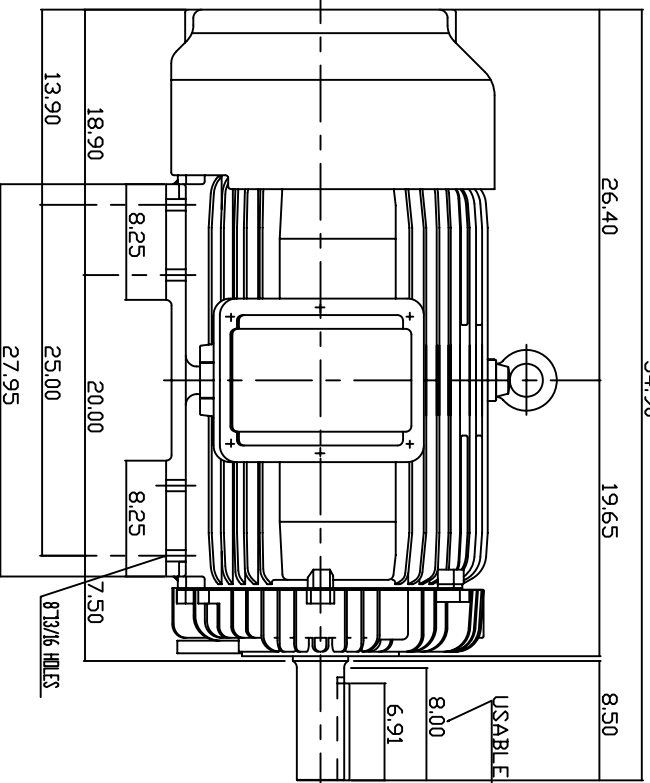

NOTE:

1. DIMENSIONS IN INCH
2. FRAME NO. 449T
3. F CLASS INSULATION, S.F.115
4. FOR DIRECT FLEXIBLE COUPLING
5. ENCLOSURE: IP55
6. BEARING SIZE: DRIVE END: 6320
NON-DRIVE END: 6316
7. APPROX. WEIGHT: 2700 LBS

TV-56C

DWN.	J. WANG	JAN -28 -2005
CHKD.	H. HUANG	JAN -28 -2005
APPD.	C. WANG	JAN -28 -2005

Nov. 15, 2006
CAT. # CP2004/8
OUTLINE DIMENSIONS
3-PHASE INDUCTION MOTOR
Dwg No. 3A040Y647-1
REV: 00