

SYM	REVISION	BY	DATE
A	REVISED & REDRAWN	BSK	8/10/95

SCALE: 1.5x

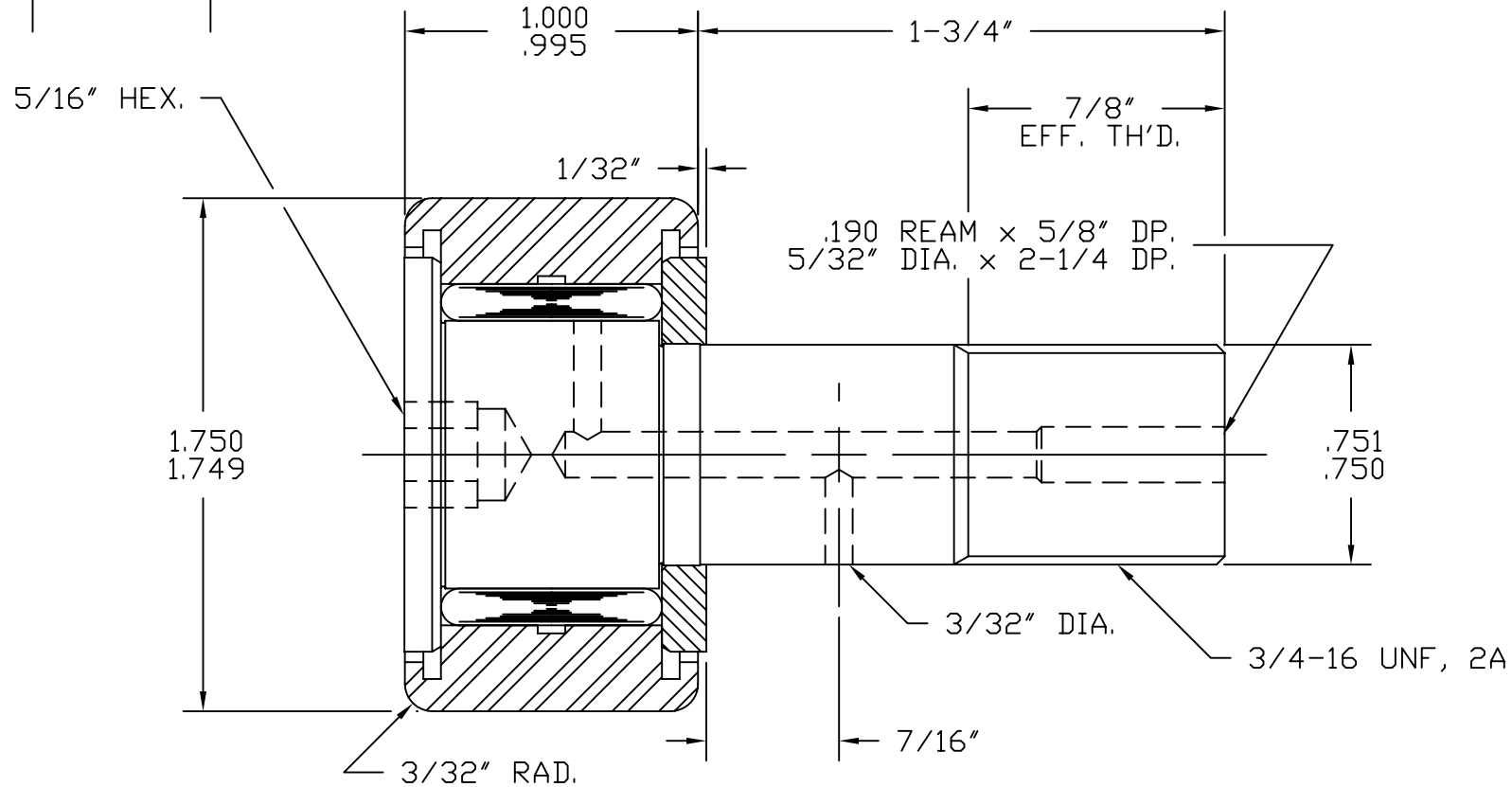

BASIC DYNAMIC CAPACITY - 6070
 MAX. ALLOWABLE LOAD - 5400

MAT'L: ST'D BEARING STEELS.
 BEARING PACKED WITH GENERAL PURPOSE EP GREASE.
 RELUBE PROVISIONS WILL ACCEPT 3/16" DRIVE TYPE
 FITTINGS, PLUGS SUPPLIED FOR UNUSED HOLES.

TOLERANCES	
UNLESS OTHERWISE NOTED	
FRACTIONS: ±.010	ANGLES: ±.5
2 PLACE DECIMALS (.00): ±.005	
3 PLACE DECIMALS (.000): ±.002	



ACCURATE BUSHING CO. INC.
 Manufacturers of SMITH® Bearing Product
 443 NORTH AVENUE
 Garwood, NJ 07027

PART NAME	STANDARD CAM FOLLOWER		
PART NO.	CR-1-3/4-B		
DRAWN BY	BSK	DATE	8/10/95
CHECKED BY		FILENAME	\CRASSYS\1-3-4-B