

SYM	REVISION	BY	DATE

SCALE ~

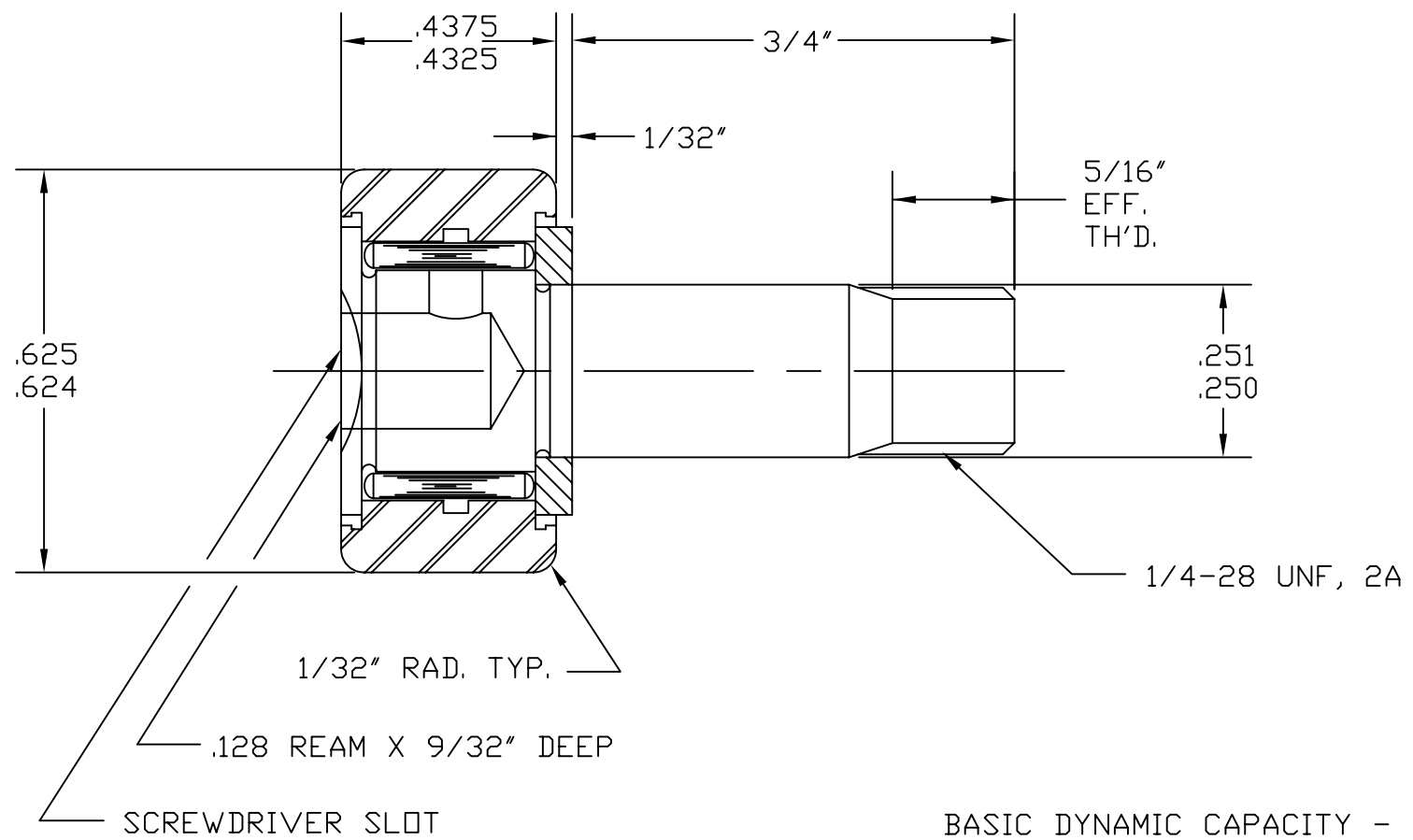

BASIC DYNAMIC CAPACITY - 940  
 MAX. ALLOWABLE LOAD - 590

MAT'L: ST'D BEARING STEELS  
 BEARING PACKED WITH GENERAL PURPOSE EP GREASE.  
 RELUBE PROVISIONS WILL ACCEPT 1/8" DRIVE TYPE  
 FITTINGS, PLUGS SUPPLIED FOR UNUSED HOLES.

TOLERANCES	
FRACTIONS ± .010	ANGLES ± .5
2 PLACE DECIMALS (.00) ± .005	
3 PLACE DECIMALS (.000) ± .002	



ACCURATE BUSHING CO. INC.  
 443 North Avenue  
 Garwood, NJ 07027

PART NAME	CAM FOLLOWER		
PART NO.	CR-5/8		
DRAWN BY	JMK	DATE	02/04/94
CHECKED BY		FILENAME	\CRASSYS\5-8