

BALDOR® • RELIANCE 

Product Information Packet

D2515P

15HP, 1750/2300RPM, DC, 288AT, TEFC, F1

Part Detail							
Revision:	D	Status:	PRD/A	Change #:		Proprietary:	No
Type:	DC	Prod. Type:		Elec. Spec:		CD Diagram:	
Enclosure:		Mfg Plant:		Mech. Spec:		Layout:	885-3
Frame:		Mounting:	F1	Poles:	00	Created Date:	04-09-2015
Base:		Rotation:	R	Insulation:		Eff. Date:	10-28-2016
Field Type:		Literature:		Elec. Diagram:		Replaced By:	

Specs			
Frame:	288AT		
Frame Material:	Steel		
Agency Approvals:	CSA		
Base Indicator:	Rigid		
Bearing Grease Type:	Polyrex EM (-20F +300F)		
Drip Cover:	No Drip Cover		
Feedback Device:	NO FEEDBACK		
Heater Indicator:	No Heater		
Insulation Class:	F		
Lifting Lugs:	Standard Lifting Lugs		
Mounting Arrangement:	F1		
Shaft Extension Location:	Pulley End		
Shaft Ground Indicator:	No Shaft Grounding		
Shaft Slinger Indicator:	No Slinger		
Motor Standards:	NEMA		

Nameplate NP1734										
CAT.NO.	D2515P			MODEL	T28R8005					
HP	15	RPM	1750/ 2300		FRAME	0288AT				
ARM V	240	ARM A	51.70		WOUND	STR. SHUNT				
FLD V	150/ 300	FLD A	1.96-1.38/.98-.69							
CONN		OHMS				CL	F			
ENCL	TEFC	DUTY	CONT			MX AMB	40			
P CODE	D	CTSR				SER.F.	1.0			
S/N			E/S	K0075A A						
O.D.E. BRG.	6209	D.E. BRG.	6210		BRUSH	28610-1				
									QTY	2

Parts List		
Part Number	Description	Quantity
SA297075	SA T28R8005	1.000 EA
AA016126	AA T28R8005	1.000 EA
NP1734	NPL,BALDOR DC MTR ALUMINUM	1.000 EA
15209	LABEL CONNECTIONS & TERMINAL MARKIN	1.000 EA
435360014	MWIRE 7 GA 004824-004BV	27.000 LB
15555-894	KEY 1/2 SQ	1.000 EA
611954052A	BAND SHL	1.000 EA
HA1085	ROTOR WASHER FOR 280 FRAME	1.000 EA
HA1085	ROTOR WASHER FOR 280 FRAME	1.000 EA
15094	DISHED LOCKWASHER .332 ID, .865 OD	2.000 EA
28026-1	FAN MACHINED FRAME 280 SERIES	1.000 EA
28347	BALANCE RING, H.R.P&O STL	2.000 EA
609848007A	NOMEX WASHER, ROUND DC 2POLE ODE	1.000 EA
032018016DK	HHCS 1/2-13X2L PLTD.	4.000 EA
032018016DK	HHCS 1/2-13X2L PLTD.	4.000 EA
046001026J	THERM N/C S06-145	1.000 EA
28037-1	INTERPOLE STACK FRAME 288	2.000 EA
424504011DB	FT. MILL 288 SHIM PACK	1.000 EA
424508201A	ROUND 288 DC FRAME INSUL BM	1.000 EA
032018038CK	HHCS 3/8X4-3/4 PLTD.	4.000 EA
035000001A	ALFTG 1/8" 1610-BL	1.000 EA
28041-1	FE BRKT MACH FR280 FOR LOCKED C.E	1.000 EA
HW4500A17	317400 ALEMITE GREASE RELIEF	1.000 EA
HW5100A10	W3519-038 WAVY WASHER, FOR 6308 BRG	1.000 EA

Parts List (continued)		
Part Number	Description	Quantity
15599-37	DRIVE SCR,#10 X.37 TYPE UPLATED STEEL	6.000 EA
004824015A	GREASE POLYREX EM	0.300 LB
032130010CA	3/8-16 X 1.25 HSHCS	4.000 EA
032130018BA	HSHCS 2-1/4" LG M2	4.000 EA
15185-12	LUBE EXTENSION 2.12 LENGTH	1.000 EA
15185-9	LUBE EXTENSION 3.38 LENGTH	1.000 EA
15548-2	LUB FITTING,PRESS-IN ALEMITE #1743-B/EQ	1.000 EA
15548-3	GREASE RELIEF,PRESS-IN ALEMITE #321381/E	1.000 EA
28040-3	CE BRKT MACH FR 280 LOCKED C.E. BR	1.000 EA
HA4048A01	DRIVE-IN PLUG,.50"EXPAN.PLUG,	2.000 EA
032018004BK	HHCS 5/16-18X1/2 PLATED	2.000 EA
15094	DISHED LOCKWASHER .332 ID, .865 OD	2.000 EA
28610-1SP	BRUSH,280/320FR. E-41HELWIG,NEW DESIGN	2.000 EA
BP5228R01	BR ROCKER ASSY,FR 28 & 32 SINGLE BRUSH	1.000 EA
032018004AK	HHCS 1/4-20X1/2 PLATED	2.000 EA
032018004BK	HHCS 5/16-18X1/2 PLATED	28.000 EA
032018006CK	HHCS 3/8-16X3/4L PLATED	4.000 EA
032018006DK	HHCS 1/2-13X3/4 PLATED	4.000 EA
032018008BK	HHCS 5/16-18X1L PLATED	4.000 EA
032018010DK	HHCS 1/2-13X1-1/4 PLATED	4.000 EA
032620012LB	5/16-18 X 3/8HXSS SCREW	2.000 EA
032620032KB	HSSS 1/4-20X1" PLTD - 360	4.000 EA
033100012AB	1/4-20 HX MACH SCREW NUT	4.000 EA
034180008FA	KEY 3/8X3/8X1L - 320	1.000 EA

Product Information Packet: D2515P - 15HP,1750/2300RPM,DC,288AT,TEFC,F1

15021-2	ACC.FACE SCR.N,1/2 #13/15 FLTND. EXP.META	1.000 EA
15024-3	TERM.BOX BASE FR-280 DUREX P/N:3CT	1.000 EA
15024-4	TERM.BOX CVR. FR-28,32,36DUREX P/N:D618	1.000 EA
15024-5	GASKET, T.BOX COVER	1.000 EA
15024-7	GASKET,T/BOX FR. 280/3201/8" THK.,MUELL	1.000 EA
150449-31	GRD STUD ARG .312DIA STUD	1.000 EA
15115	TERM BOX HOLE COVER FRAME 280 & 320	1.000 EA
15442	COVER RING TEFC ACC FACE #14 GA CR	1.000 EA
28020-1	ACCESS COVER FRAME 28 SERIES #14 GA STE	3.000 EA
28020-2	ACCESS COVER FRAME 28 SERIES	1.000 EA
28020-2	ACCESS COVER FRAME 28 SERIES	2.000 EA
28021-1	GASKET,CVR,FAN END,FR.2803/32 THK DC205(3.000 EA
28021-2	GASKET COVER COM END FRAME 280 SERIES	3.000 EA
28022-2	SOLID SMILE COVER,FR 280	1.000 EA
28048-1	'C' FACE COVER MACH FRAME 280, T.E.F.C.	1.000 EA
28049-1	FAN MACHINING FRAME 280, T.E.F.C.	1.000 EA
28491	SHROUD & GUARD ASSY FR 280 SERIES	1.000 EA
MG1025G05	WILKOFAS, 789.227, MED. GRAY CHAR. MET.	0.100 GA
034180020GA	KEY 1/2X1/2X2-1/2 L	1.000 EA
PA1100	PACK FOR #1 SKID; CUSTOM	1.000 EA
MG5047	VARNISH 004824-001HM	0.200 GA
041009038F	INT. LEAD LUG	2.000 EA
041009038A	TERMINAL LUG WIRE 22-16	4.000 EA
482413015Y	#15 SLVG	6.000 FT
482413007Y	#7 SLEEVING (GREEN)	6.000 FT

Accessories		
Part Number	Description	Multiplier
93EP5000A01	C-FACE CONVERSION KIT FOR STOCK MTR,FR 2	

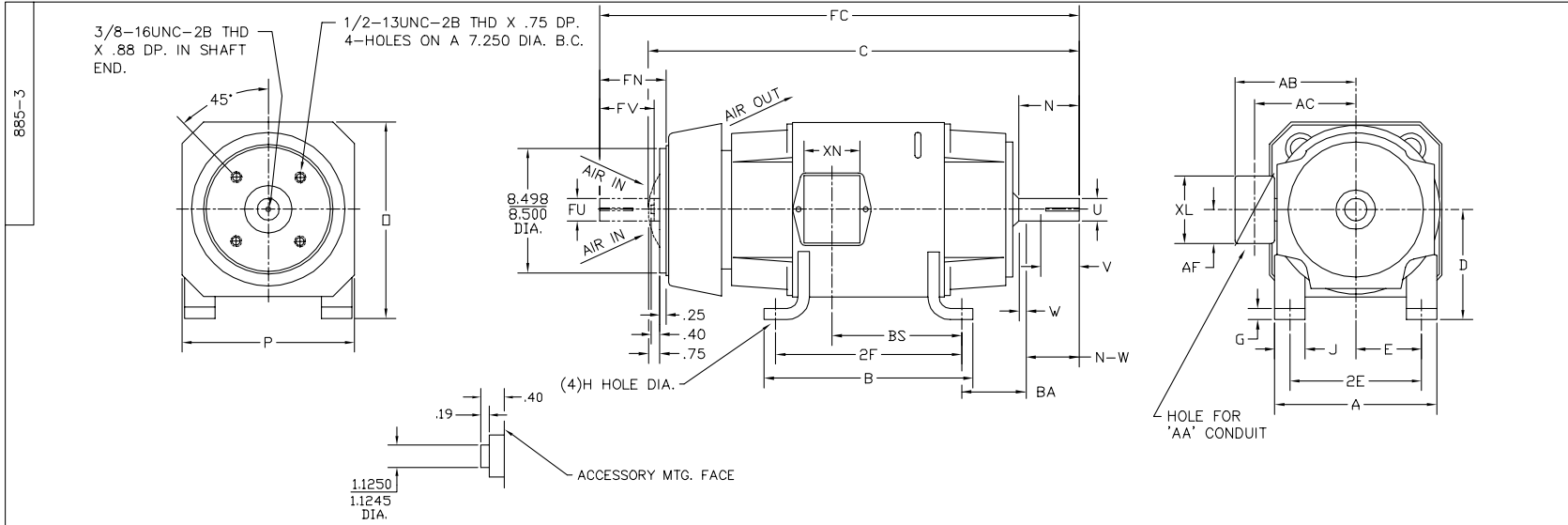

FRAME	FOOT MOUNTING						D.E. SHAFT EXTENSION						DRIVE KEY		ACC SHAFT EXTENSION			ACC KEY		FRAME					
	BA	E	2F	G	H	J	N	N-W	U	V	W	KEY-SQ.	KEY-LONG	FN	FU	FV	KEY-SQ.	KEY-LONG	A	B	C	FC	D	O	P
287AT	4.75	5.50	12.50	.69	.531	2.50	3.91	3.75	1.875	3.50 ³	.16	.500	2.50	3.44	1.625	3.19	.375	2.44	13.81	14.13	34.09	37.08	7.00 ²	13.88	13.75
288AT	4.75	5.50	14.00	.69	.531	2.50	3.91	3.75	1.875	3.50 ³	.16	.500	2.50	3.44	1.625	3.19	.375	2.44	13.81	15.62	35.84	39.25	7.00 ²	13.88	13.75
2810AT	4.75	5.50	18.00	.69	.531	2.50	3.91	3.75	1.875	3.50 ³	.16	.500	2.50	3.44	1.625	3.19	.375	2.44	13.81	19.62	39.84	42.54	7.00 ²	13.88	13.75
2811AT	4.75	5.50	20.00	.69	.531	2.50	3.91	3.75	1.875	3.50 ³	.16	.500	2.50	3.44	1.625	3.19	.375	2.44	13.81	21.62	43.84	45.83	7.00 ²	13.88	13.75
2813AT	4.75	5.50	25.00	.69	.531	2.50	3.91	3.75	1.875	3.50 ³	.16	.500	2.50	3.44	1.625	3.19	.375	2.44	13.81	26.62	47.84	49.12	7.00 ²	13.88	13.75

FRAME	CONDUIT BOX							ARM APPROX. WK ² LBS.FT. ²	APPROXIMATE WEIGHT
	AA	AB	AC	AF	BS	XL	XN		
287AT	1 1/4	11.88	9.25	5.00	10.89	7.88	5.25	4.67	556 ⁵
288AT	1 1/4	11.88	9.25	5.00	12.64	7.88	5.25	5.36	616 ⁵
2810AT	1 1/4	11.88	9.25	5.00	16.64	7.88	5.25	6.80	776 ⁵
2811AT	1 1/4	11.88	9.25	5.00	19.14	7.88	5.25	7.62	785 ⁵
2813AT	1 1/4	11.88	9.25	5.00	23.64	7.88	5.25	9.40	792 ⁵

- 1) SHAFT DIAMETERS TO 1.500 TOLERANCE +.0000 -.0005
 SHAFT DIAMETERS ABOVE 1.500 TOLERANCE +.0000 -.0010
 SHAFT DIAMETERS TO 1.625 RUNOUT .002 T.I.R. MAX.
 SHAFT DIAMETERS ABOVE 1.625 RUNOUT .003 T.I.R. MAX.
- 2) 'D' DIMENSION TOLERANCE +.000 - .060
- 3) 'V' DIMENSION IS MAX. HUB LENGTH ON SHAFT
- 4) CONDUIT BOX CAN BE ROTATED IN 90° STEPS ON ITS OWN AXIS.
- 5) TOTAL WEIGHT OF MOTOR AND FAN COOLED PACKAGE.
- 6) ALL DIMENSIONS NOT NOTED ARE NOMINAL DIMENSIONS CONSULT FACTORY FOR TOLERANCES.

FOR F1 OR F2 CONDUIT BOX LOCATION SEE SALES ORDER

CUSTOMER IS RESPONSIBLE FOR DETERMINING THAT BALDOR'S PRODUCT WILL PERFORM SUITABLY IN THE INTENDED APPLICATION.
 REV. DESC: RELOAD DRAWING TO BUS
 REV. LTR: C VERSION: 02 TDR: 000000780453
 FILE: \RGG\00019\543 REVISED: 03:11:12 01/09/2013 BY: RGGWT
 MTL: -

BALDOR
 DIM SHEET
 SH 1 of 1

Marketing maintained PDF of MN605:

<http://www.baldor.com/support/Literature/Load.ashx/MN605?ManNumber=MN605>