

**BALDOR® • RELIANCE** 

**Product Information Packet**

**D2525R**

**25 1750/2300 MC2812ATZ TEFC 240V**

Part Detail							
Revision:	-	Status:	PRD/A	Change #:		Proprietary:	No
Type:	DC	Prod. Type:		Elec. Spec:	G6317A B	CD Diagram:	406770-001
Enclosure:	TEFC	Mfg Plant:		Mech. Spec:		Layout:	609951-013
Frame:	MC281	Mounting:	F1	Poles:	00	Created Date:	04-10-2015
Base:		Rotation:	R	Insulation:	F	Eff. Date:	04-13-2015
Field Type:		Literature:		Elec. Diagram:		Replaced By:	

Specs			
Enclosure:	TEFC		
Frame:	MC2812ATZ		
Frame Material:	Exposed Laminations		
Agency Approvals:	CCSA US		
Base Indicator:	Rigid		
Bearing Grease Type:	Polyrex EM (-20F +300F)		
Drip Cover:	No Drip Cover		
Duty Rating:	CONT		
Feedback Device:	NO FEEDBACK		
Field Winding Type:	STAB SHUNT		
Frame Prefix:	MC		
Heater Indicator:	No Heater		
Insulation Class:	F		
Lifting Lugs:	Standard Lifting Lugs		
Mounting Arrangement:	F1		
Shaft Extension Location:	Pulley End		

<b>Shaft Ground Indicator:</b>	No Shaft Grounding		
<b>Shaft Slinger Indicator:</b>	No Slinger		
<b>Motor Standards:</b>	NEMA		

<b>Nameplate 000613006HP</b>	
<b>CAT.NO.</b>	D2525R
<b>FR</b>	MC 2812ATZ
<b>ENCL.</b>	TEFC
<b>ENCL MOD</b>	
<b>MAX SAFE SPEED</b>	4500
<b>FIELD DATA</b>	
<b>WINDING</b>	STAB SHUNT
<b>VOLTS</b>	150
<b>MAX AMPS @ 25 C</b>	4.05
<b>HOT AMPS</b>	2.73/ 1.96
	BRUSH:419904051AB
<b>SPEC NO.</b>	T28S0301
<b>HP</b>	25
<b>RPM</b>	1750/ 2300
<b>VOLTS</b>	240
<b>AMPS</b>	87.00
<b>SER.NO.</b>	
<b>DUTY</b>	CONT
<b>S.F.</b>	1.0
<b>INSUL</b>	F
<b>AMB.</b>	40
<b>POWER CODE</b>	C
<b>D.E. BRG.</b>	65BC03J30X
<b>O.D.E. BRG.</b>	55BC02J30X
<b>MIN. AMB.</b>	0
<b>TYPE</b>	TR

Parts List		
Part Number	Description	Quantity
SA297071	SA T28S0301	1.000 EA
AA016122	AA T28S0301	1.000 EA
000613006HP	NAMEPLATE - RPM III D-C MOTOR W/CSA LOGO	1.000 EA
000692000FP	NP, WARNING LIFT INSTRUCTIONS	1.000 EA
000692000FS	WARNING LABEL	1.000 EA
036170004EA	ROUND HEAD DRIVE SCREW	6.000 EA
406770001	C/D TAG (STAB SHUNT)	1.000 EA
036000020HB	HHCS M6-1.0X20MM PLATED	4.000 EA
036000020KB	MHHCS M10-1.5X20MM PLTD.	4.000 EA
036501008AB	KPNUT M6-1.0 ZINCPLETED	8.000 EA
036610010AB	MHSLW M10 PLATED	4.000 EA
419904051AB	BRUSH EXTRUDER DUTY C	8.000 EA
419905003A	FLAT WASHER ROCKER RPM III RGG	4.000 EA
419905008A	HARDWARE	8.000 EA
706364051RE	BRHLD METRIC SPRING CHG.	4.000 EA
706372011RG	BR STUD/ROCKER	1.000 EA
034530018AB	P/NIP 1/8X2-1/4L PLATED	1.000 EA
034630001AJ	1/8" PIPE COUPLING	1.000 EA
034693001AB	PPLG - G508- use 034692001AB	1.000 EA
034693001AB	PPLG - G508- use 034692001AB	1.000 EA
035000001A	ALFTG 1/8" 1610-BL	1.000 EA
035000001A	ALFTG 1/8" 1610-BL	1.000 EA
036000075KB	HHCS M10 75MM ZINCPLAT	3.000 EA
036100060JA	M8-1.25 X 60MM HXSOCHDCS	3.000 EA

Parts List (continued)		
Part Number	Description	Quantity
036500011AB	METRIC NUT M12-1.75 PLT.	4.000 EA
036500011AB	METRIC NUT M12-1.75 PLT.	4.000 EA
048977006C	GRFTG - XP	1.000 EA
400638001AD	WAVEN - 400	1.000 EA
418150003A	GREASE FITTING CAP	2.000 EA
609830005V	TBOLT METRIC RP609830-	4.000 EA
801928055A	BRKT,ODE,C280	1.000 EA
801929052A	BRKT,DE,C280	1.000 EA
032018004AK	HHCS 1/4-20X1/2 PLATED	4.000 EA
032018004CK	HHCS 3/8-16X1/2L PLATED	5.000 EA
032018012DK	HHCS 1/2-13X1-1/2 PLTD.	4.000 EA
034001012AB	WSHR 1/4" PLATED	4.000 EA
034017016AB	LCKW 1/2" PLATED	4.000 EA
034180014GA	KEY 1/2X1/2X1-3/4 L	1.000 EA
036000012HB	HHCS M6X12MM LONG PLATED	4.000 EA
036000045JB	M8-1.25 X 45MM HXHCS	4.000 EA
036620009AB	M8 EXTERNAL LK WASHER	1.000 EA
074875000A	CONDUIT BOX COVER	1.000 EA
078549001SA	(006) FAN	1.000 EA
402731000A	GASK 320-400	1.000 EA
412043002K	BPLUG	1.000 EA
415072001B	CLAMP	1.000 EA
417733004D	GASKET CONDUIT BOX	2.000 EA
418014004A	ADAPT 418014-4WCA	1.000 EA

Product Information Packet: D2525R - 25 1750/2300 MC2812ATZ TEFC 240V

418018074A	GROUND LABEL G100 METRIC 160 D.C.	1.000 EA
422919053	HHCVR KIT, C280, DE, XT	1.000 EA
422919053	HHCVR KIT, C280, DE, XT	1.000 EA
422919053	HHCVR KIT, C280, DE, XT	1.000 EA
422919064	HHCVR KIT, C280, ODE, SOLID	1.000 EA
422919064	HHCVR KIT, C280, ODE, SOLID	1.000 EA
422919064	HHCVR KIT, C280, ODE, SOLID	1.000 EA
603909004A	GRILL, FAN	1.000 EA
706320009A	CB, 2.00 CONDUIT, METRIC, SHEET METAL	1.000 EA
706365003A	FNGRL	1.000 EA
801955001A	FNCVR 801955-1WCA	1.000 EA
000640000P	TAG WINDING THERMOST	1.000 EA
000692000NG	LABEL ;NP 4POLE METRIC LABEL	1.000 EA
034180028HA	KEY 5/8X5/8X3-1/2L-445	1.000 EA

609951-013

## INDUSTRIAL DIRECT CURRENT MOTORS AND GENERATORS - RPM III

ENCLOSURE: TOTALLY ENCLOSED  
MOUNTING: FOOT  
METHOD OF DRIVE: COUPLED OR BELTED

COOLING: FAN COOLED  
ACCESSORIES: PROVISION FOR  
TACHOMETER MOUNTING  
ONLY WHEN SPECIFIED

FRAMES SC2113ATZ THRU LC2812ATZ

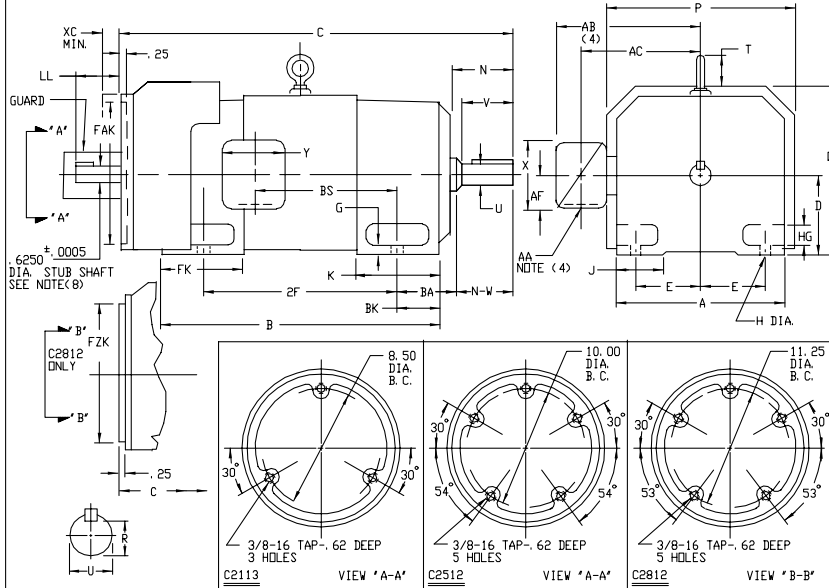

DIMENSIONS ARE IN INCHES

FRAME	A	B(1)	E	G	H	HG	J	D	P	T	BA	K	FK	BK	FAK(6)	FZK(7)	XC(5)
SC2113ATZ-LC2113ATZ	10.25	5.25	4.25	.44	.44	1.38	1.75	11.62	12.75	1.38	3.50	5.19	6.81	2.38	9.750	N/A	1.25
SC2512ATZ-LC2512ATZ	12.31	6.25	5.00	.50	.56	1.62	2.00	13.62	14.75	1.94	4.25	6.06	8.00	3.00	11.250	N/A	1.25
MC2812ATZ-LC2812ATZ	13.78	7.00	5.50	.62	.56	1.88	2.75	15.06	16.12	2.31	4.75	6.75	9.19	3.50	N/A	12.500	1.25

FRAME	C	B	BS	ZF	DRIVE END SHAFT AND KEY				WT.			
					N	N-V	UK(2)	V		RK(3)	SD	LGTH.
SC2113ATZ	32.19	22.50	11.38	18.00	4.00	3.75	1.875	3.50	1.591	500	2.50	355
MC2113ATZ	33.44	23.75	12.62	18.00	4.00	3.75	1.875	3.50	1.591	500	2.50	380
LC2113ATZ	35.06	25.38	14.25	18.00	4.00	3.75	1.875	3.50	1.591	500	2.50	410
SC2512ATZ	35.94	25.06	12.06	20.00	4.50	4.25	2.125	4.00	1.845	500	3.00	355
MC2512ATZ	37.44	26.56	13.56	20.00	4.50	4.25	2.125	4.00	1.845	500	3.00	590
LC2512ATZ	38.94	28.06	15.06	20.00	4.50	4.25	2.125	4.00	1.845	500	3.00	630
MC2812ATZ	41.62	29.94	14.25	22.00	5.00	4.75	2.375	4.50	2.021	625	3.50	835
LC2812ATZ	43.88	32.19	16.50	22.00	5.00	4.75	2.375	4.50	2.021	625	3.50	900

- (1) 'B' DIMENSION WILL NOT BE EXCEEDED. SHIMS UP TO .03 INCHES IN THICKNESS ARE USUALLY REQUIRED FOR COUPLED OR GEARED MACHINES.
  - (2) 'U' VARIES----4.000 - .001
  - (3) 'R' VARIES----4.000 - .015
  - (4) TERMINAL BOX VARIES WITH H.P. FOR DIMENSIONS 'AA', 'AB', 'AC', 'AF', 'X' AND 'Y'. SEE DRAWING NUMBER 609959-1.
  - (5) WALLS OR OBSTRUCTIONS MUST NOT ENCRDACH ON AIR INLET SPACE 'XC'.
  - (6) 'FAK' VARIES + .005 - .000----FACE RUNDUT AND ECCENTRICITY .007 MAX. T. I. R.
  - (7) 'FZK' VARIES + .000 - .005----FACE RUNDUT AND ECCENTRICITY .007 MAX. T. I. R.
  - (8) STUB SHAFT SUPPLIED ONLY WHEN SPECIFIED. KEY SIZE .188 X .188 X 1.00
  - (9) FOR RE-045 DR SPY PROVISIONS ON 'C2812' ADD 1.00 TO 'LL' DIMENSION.
- TERMINAL BOX CAN BE ROTATED FOR LEAD OUTLET AT TOP, SIDES OR BOTTOM  
TERMINAL BOX LOCATED ON OPPOSITE SIDE WHEN F-2, W-1, W-4, W-5, W-7,  
DR, C-1 MOUNTING IS SPECIFIED. BOX LOCATED ON TOP WHEN SPECIFIED.  
MOTOR HEIGHT MAY VARY 15% FOR NON-STANDARD RATINGS AND/OR ACCESSORIES.  
IF MOUNTING CLEARANCE DETAILS ARE REQUIRED, CONSULT FACTORY.

TACHOMETER	LL
BC-42	4.25
BC-46	
RD-11	
RD-12	
RD-51	
RD-61	
RD-62	
RE-210	
M627, M628	
M727, M737	
M738	3.80
DINAPAR 745	
RE-045	1.12
SPY	SEE NOTE (9)

CUSTOMER IS RESPONSIBLE FOR DETERMINING THAT BALDOR'S PRODUCT WILL PERFORM SUITABLY IN THE INTENDED APPLICATION.

REV. DESC: LOADED TO BUS	VERSION: 00	TDR: 000000577407
REV. LTR: -	REVISED: 11:02:01 01/26/2011	BY: CONNAS
FILE: \RGG\00015\557		
MTL: -		

**BALDOR**

DIMENSION DRAWING, SC2113ATZ - LC2812ATZ, TEFC, FOOT MTG

SH 1 of 1

609951-013



609959-001

**INDUSTRIAL DIRECT CURRENT MOTORS  
AND GENERATORS - RPM III**  
TERMINAL BOX DIMENSIONS  
STANDARD SIZE AND ONE SIZE LARGER  
FRAMES C2113ATZ THRU C2815ATZ

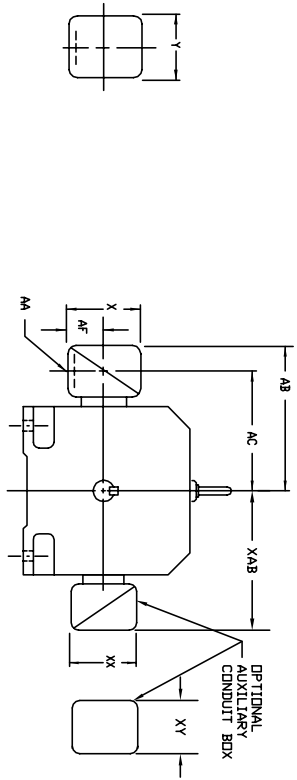

DIMENSIONS ARE IN INCHES

FRAME SIZE	STANDARD SIZE						ONE SIZE LARGER								
	MAX. AMPS	AK(1)	AB	AC	AF	PART NUMBER	AK(1)	AB	AC	AF	PART NUMBER				
C2113ATZ	40	3/4 & 1"	8.97	7.47	1.94	4.38	5.00	7.05029-1-R	1-1/4 & 1-1/2	10.03	8.03	2.50	5.50	6.12	7.05029-1-R
C2115ATZ	96	1-1/4 & 1-1/2	10.03	8.03	2.50	5.50	6.12	7.05029-1-R	2" & 2-1/2	11.16	8.41	3.19	7.00	7.62	7.05030-1-R
(2)	208	2" & 2-1/2	11.16	8.41	3.19	7.00	7.62	7.05030-1-R	2" & 2-1/2	11.16	8.41	3.19	7.00	7.62	7.05030-1-R
C2513ATZ	40	3/4 & 1"	10.03	8.53	1.94	4.38	5.00	7.05029-1-R	1-1/4 & 1-1/2	11.09	9.09	2.50	5.50	6.12	7.05029-1-R
C2515ATZ	96	1-1/4 & 1-1/2	11.09	9.09	2.50	5.50	6.12	7.05029-1-R	2" & 2-1/2	12.22	9.47	3.19	7.00	7.62	7.05030-1-R
(2)	208	2" & 2-1/2	12.22	9.47	3.19	7.00	7.62	7.05030-1-R	2" & 2-1/2	12.22	9.47	3.19	7.00	7.62	7.05030-1-R
C2813ATZ	128	2"	14.03	10.53	4.25	8.44	7.25	7.4874-R	3"	14.47	11.22	4.25	8.44	7.25	7.4874-R
C2815ATZ	185	3"	14.47	11.22	4.25	8.44	7.25	7.4874-R	4"	15.91	11.84	5.38	10.56	9.00	7.0308-3-R
(2)	259	4"	15.91	11.84	5.38	10.56	9.00	7.0308-3-R	5" (4)	18.72	13.47	7.00	12.75	15.00	7.02658-1-C

FRAME SIZE	STANDARD SIZE						ONE SIZE LARGER								
	MAX. AMPS	AK(3)	AB	AC	AF	PART NUMBER	AK(3)	AB	AC	AF	PART NUMBER				
C2113ATZ	18	3/4	10.03	8.03	2.50	5.00	5.75	7.05028-2-S	1"	10.03	8.03	2.50	5.00	5.75	7.05028-2-T
C2115ATZ	40	1"	10.03	8.03	2.50	5.00	5.75	7.05028-2-R	1-1/2	10.97	8.53	3.00	6.00	7.00	7.05029-2-S
(2)	96	1-1/2	10.97	8.53	3.00	6.00	7.00	7.05029-2-R	2"	10.97	8.53	3.00	6.00	7.00	7.05029-2-S
208	2"	10.97	8.53	3.00	6.00	7.00	7.05029-2-S	2-1/2	12.66	8.91	3.62	7.88	9.23	7.05029-2-R	
18	3/4	11.09	9.09	2.50	5.00	5.75	7.05028-2-S	1"	11.09	9.09	2.50	5.00	5.75	7.05028-2-T	
C2513ATZ	40	1"	11.09	9.09	2.50	5.00	5.75	7.05028-2-T	1-1/2	12.03	9.59	3.00	6.00	7.00	7.05029-2-R
C2515ATZ	96	1-1/2	12.03	9.59	3.00	6.00	7.00	7.05029-2-S	2"	12.03	9.59	3.00	6.00	7.00	7.05029-2-S
(2)	208	2"	12.03	9.59	3.00	6.00	7.00	7.05029-2-R	2-1/2	13.72	9.97	3.62	7.88	9.23	7.05030-2-R
C2813ATZ	128	2"	12.78	10.34	3.00	6.00	7.00	7.5460-T	3"	14.47	10.72	3.62	7.88	9.23	7.6700-R
C2815ATZ	185	3"	14.47	10.72	3.62	7.88	9.23	7.6700-R	4"	15.78	11.59	4.12	9.50	10.50	7.6700-R
(2)	259	4"	15.78	11.59	4.12	9.50	10.50	7.6700-R	5" (4)	18.59	13.34	7.00	12.75	15.00	7.6870-S

FRAME SIZE	STANDARD SIZE						ONE SIZE LARGER					
	AMP(S)	AB	AC	AF	X	Y	AB	AC	AF	X	Y	
C210	100	10.71	8.98	2.72	7.48	7.48	7.48	7.48	7.48	7.48	7.48	
200	11.26	9.25	3.35	8.82	8.82	8.82	8.82	8.82	8.82	8.82	8.82	
100	11.30	9.57	2.72	7.48	7.48	7.48	7.48	7.48	7.48	7.48	7.48	
200	11.85	9.84	3.35	8.82	8.82	8.82	8.82	8.82	8.82	8.82	8.82	
400	17.48	12.75	6.20	14.39	14.39	14.39	14.39	14.39	14.39	14.39	14.39	
800	17.48	12.75	6.20	14.39	14.39	14.39	14.39	14.39	14.39	14.39	14.39	
200	12.60	10.99	3.76	8.82	8.82	8.82	8.82	8.82	8.82	8.82	8.82	
400	18.27	13.54	6.20	14.39	14.39	14.39	14.39	14.39	14.39	14.39	14.39	
800	18.27	13.54	6.20	14.39	14.39	14.39	14.39	14.39	14.39	14.39	14.39	
1600	18.27	13.54	7.68	15.35	15.35	15.35	15.35	15.35	15.35	15.35	15.35	

(1) \*AM. CONDUIT  
(2) STEEL TERMINAL BOX FOR C2113ATZ AND C2515ATZ  
(3) \*AM. PIPE TAP  
(4) TERMINAL BOX 76870-9R EXTENDS BELOW MOTOR FEET.  
TERMINAL BOX CAN BE ROTATED FOR LEAD DULLET AT TOP, SIDES OR BOTTOM.  
TERMINAL BOX LOCATED ON OPPOSITE SIDE WHEN F-2, V-1, V-4, V-5, V-7,  
OR C-1 MOUNTING IS SPECIFIED. BOX LOCATED ON TOP WHEN SPECIFIED.  
FOR \*X/P TERMINAL BOX DIMENSIONS SEE 609959-2.  
FOR \*\*X/P TERMINAL BOX DIMENSIONS SEE 609959-3.

FRAME SIZE	OPTIONAL AUXILIARY CONDUIT BOX DIMENSIONS (MAXIMUM)								
	XAB	XX	XY	Y	PART NUMBER	PART NUMBER			
C210	7.38	4.25	4.25	6.02007-26-A	C210	10.88	8.00	8.00	7.06310-3-B
C250	8.44	4.25	4.25	6.02007-26-A	C250	11.88	8.00	8.00	7.06310-3-B
C280	9.12	4.25	4.25	6.02007-26-A	C280	12.62	8.00	8.00	7.06310-3-B

CUSTOMER IS RESPONSIBLE FOR DETERMINING THAT BALDOR'S PRODUCT WILL PERFORM SUITABLY IN THE INTENDED APPLICATION.

REV. DESC: ADD 706310-63G C/BOX TO C250 AND C280 FRAMES	VERSION: 01	TDR: 000000816512
REV. LTR: A		
FILE: \RGG\00021\153		REVISED: 03:09:09 09/06/2013
MTL: -		BY: RGGWT



DIMENSION SHEET  
SH 1 of 1

609959-001

406770-001

406770-001

**CONNECTION DIAGRAM  
D-C MOTOR - STAB. SHUNT**

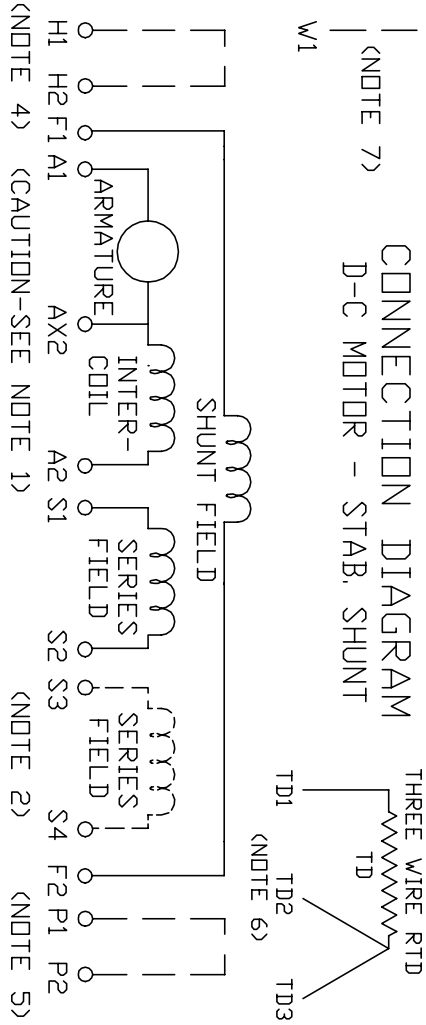

ARMATURE AND FIELD EXTERNAL CONNECTIONS  
WARNING- SEE NOTE 8 FOR GROUNDING INSTRUCTIONS



ROTATION FACING COMMUTATOR END

- CAUTION** — ARMATURE AND SERIES FIELD MAY HAVE MULTIPLE LEADS. CONNECT ALL LUGS WITH THE SAME MARKING TOGETHER.
  - OPTIONAL SERIES FIELD IS MARKED S3 AND S4. FOR CUMULATIVE SERIES FIELD, CONNECT S3 TO S2 AND CONNECT S4 TO NEGATIVE. FOR DIFFERENTIAL SERIES FIELD CONNECT S4 TO S2 AND S3 TO NEGATIVE.
  - OPTIONAL CONTROL SIGNAL LEAD IS MARKED AX2. ALWAYS TAKE INTERPOLE DROP BETWEEN A2 AND AX2. NOTE: NEMA DESIGNATION FOR AX2 IS LETTER C.
  - SPACE HEATERS, WHEN PROVIDED, WILL HAVE LEADS MARKED H1 AND H2, H3, H4, ETC.
  - THERMAL PROTECTOR, WHEN PROVIDED, WILL HAVE LEADS MARKED P1 AND P2, P3, P4, ETC.
  - WINDING RTD'S, WHEN PROVIDED, WILL HAVE LEADS MARKED TD1, TD2, & TD3
  - BRUSH WEAR SENSOR, WHEN PROVIDED, WILL HAVE LEAD MARKED W1.
  - WARNING** — MOTOR MUST BE GROUNDED TO PREVENT SERIOUS INJURIES TO PERSONNEL. GROUND THE MOTOR PER IEC, NATIONAL ELECTRICAL CODE AND ANY APPLICABLE LOCAL ELECTRICAL CODES. A TAPPED HOLE IS PROVIDED IN THE CONDUIT BOX, ON THE FOOT. FRAME BRACE OR OPPOSITE DRIVE END BRACKET, ADJACENT TO THE TERMINAL BOX FOR MOTOR GROUNDING. GROUND LEAD, WHEN PROVIDED, WILL BE GREEN.
- CUSTOMER \_\_\_\_\_ RELIANCE  
CUSTOMER ORDER NO. \_\_\_\_\_ S.D. NO. \_\_\_\_\_

REV. DESC: DELETED DUPLICATE WORDS FROM NOTE 8		
REV. LTR: A	VERSION: 01	TDR: 000000970330
FILE: \RSN\00026\422	REVISED: 10:19:12 03/11/2016	BY: RAGTBM
MTL: -		

**BALDOR**

D-C MOTOR CONNECTION DIAGRAM STAB. SHUNT

SH 1 of 1