

BALDOR® • RELIANCE 

Product Information Packet

D5015R-BV

15HP,1750RPM,DC,2113ATZ,DPG-FV,

Part Detail							
Revision:	-	Status:	PRD/A	Change #:		Proprietary:	No
Type:	DC	Prod. Type:		Elec. Spec:	G6224C B	CD Diagram:	406770-006
Enclosure:	DP	Mfg Plant:		Mech. Spec:		Layout:	616002-001
Frame:	SC211	Mounting:	F1	Poles:	00	Created Date:	04-09-2015
Base:		Rotation:	R	Insulation:	F	Eff. Date:	04-13-2015
Field Type:		Literature:		Elec. Diagram:		Replaced By:	

Specs			
Enclosure:	DP		
Frame:	SC2113ATZ		
Frame Material:	Exposed Laminations		
Agency Approvals:	CCSA US		
Base Indicator:	Rigid		
Bearing Grease Type:	Polyrex EM (-20F +300F)		
Drip Cover:	No Drip Cover		
Duty Rating:	CONT		
Feedback Device:	NO FEEDBACK		
Field Winding Type:	STR SHUNT		
Frame Prefix:	SC		
Heater Indicator:	No Heater		
Insulation Class:	F		
Lifting Lugs:	Standard Lifting Lugs		
Mounting Arrangement:	F1		
Shaft Extension Location:	Pulley End		

Shaft Ground Indicator:	No Shaft Grounding		
Shaft Slinger Indicator:	No Slinger		
Motor Standards:	NEMA		

Nameplate 000613006HP			
CAT.NO.	D5015R-BV	SPEC NO.	T21T1364
FR	SC 2113ATZ	HP	15
ENCL.	DP	DUTY	CONT
ENCL MOD	FORCE VENT	RPM	1750/ 2300
MAX SAFE SPEED	4500	VOLTS	500
		AMPS	27.00
		SER.NO.	
		POWER CODE	C
		D.E. BRG.	50BC03J30X
		O.D.E. BRG.	45BC02J30X
		MIN. AMB.	0
		INSUL	F
		AMB.	40
		TYPE	TR
		FIELD DATA	
WINDING	STR SHUNT		
VOLTS	300		
MAX AMPS @ 25 C	2.24		
HOT AMPS	1.69/ 1.15		
	BRUSH:419904051AB		

Parts List		
Part Number	Description	Quantity
SA297125	SA T21T1364	1.000 EA
AA016159	AA T21T1364	1.000 EA
000613006HP	NAMEPLATE - RPM III D-C MOTOR W/CSA LOGO	1.000 EA
000692000FP	NP, WARNING LIFT INSTRUCTIONS	1.000 EA
000692000FS	WARNING LABEL	1.000 EA
418057747A	METAL FASTENER	8.000 EA
406770006	C/D TAG STRAIGHT SHUNT	1.000 EA
036000012HB	HHCS M6X12MM LONG PLATED	4.000 EA
036000020KB	MHHCS M10-1.5X20MM PLTD.	4.000 EA
036501008AB	KPNUT M6-1.0 ZINCPLETED	8.000 EA
036610010AB	MHSLW M10 PLATED	4.000 EA
419904051AB	BRUSH EXTRUDER DUTY C	4.000 EA
419905003A	FLAT WASHER ROCKER RPM III RGG	4.000 EA
419905008A	HARDWARE	8.000 EA
706364051AA	BRHLD ADD HARDWARE	4.000 EA
706372001B	ROCKR METRIC	1.000 EA
004824015A	GREASE POLYREX EM	0.100 LB
034693001AB	PPLG - G508- use 034692001AB	1.000 EA
034693001AB	PPLG - G508- use 034692001AB	1.000 EA
035000001A	ALFTG 1/8" 1610-BL	1.000 EA
035000001BB	GREASE FTG,GRS.IN	1.000 EA
036000055JB	HHCS,DE CAP	2.000 EA
036000060KB	HHCS,DE CAP	3.000 EA
036500010AB	METRIC NUT M10-1.5PLTD400	4.000 EA

Parts List (continued)		
Part Number	Description	Quantity
036500010AB	METRIC NUT M10-1.5PLTD400	4.000 EA
048977006B	GRFTG - XP	1.000 EA
400638001H	SPRING WASHER	1.000 EA
418150003A	GREASE FITTING CAP	2.000 EA
609830005M	TBOLT METRIC RP609830-	4.000 EA
801924102A	BRKT,ODE,C210	1.000 EA
801925102A	BRKT,DE,C210	1.000 EA
000613006NT	NAME PLATE IEC	1.000 EA
032018004CK	HHCS 3/8-16X1/2L PLATED	4.000 EA
032018006CK	HHCS 3/8-16X3/4L PLATED	4.000 EA
034017014AB	LCKW 3/8 STD. PLATED	4.000 EA
036000012HB	HHCS M6X12MM LONG PLATED	2.000 EA
036000012JB	M8-1.25 X 12MM HXHDC	3.000 EA
036000020JB	HHCS M8-1.25X20L PLTD-250	4.000 EA
036000045JB	M8-1.25 X 45MM HXHCS	4.000 EA
036600009AB	METRIC FLWASH M8 PLATED	3.000 EA
036620009AB	M8 EXTERNAL LK WASHER	1.000 EA
065530000B	GASK	1.000 EA
075451000A	COVER, CONDUIT BOX	1.000 EA
410978010C	FLANGE, INLET BLOWER HSG.	1.000 EA
410978019A	SCREEN, INLET FLANGE	1.000 EA
415000103G	TLUG	1.000 EA
417733001G	GASKT	2.000 EA
418010006A	CAST,MPLATE,180-280,EX1,7BY	1.000 EA

Product Information Packet: D5015R-BV - 15HP,1750RPM,DC,2113ATZ,DPG-FV,

418018074A	GROUND LABEL G100 METRIC 160 D.C.	1.000 EA
422919001	CVRKT BE SOLID C210	1.000 EA
422919003	HHCVR KIT,C210,DE,LOUVERED	1.000 EA
422919003	HHCVR KIT,C210,DE,LOUVERED	1.000 EA
422919012	HHCVR KIT,C210,ODE,SOLID	1.000 EA
422919012	HHCVR KIT,C210,ODE,SOLID	1.000 EA
422919012	HHCVR KIT,C210,ODE,SOLID	1.000 EA
610490001AH	.75HP,3450//2850RPM,3PH,60//50HZ,56C,351	1.000 EA
611917002A	GASKT	1.000 EA
611965001A	WHEEL, BLOWER	1.000 EA
706305026A	GUARD,SHAFT	1.000 EA
706320003A	CONDUIT BOX	1.000 EA
708528004G	HOUSING, BLOWER	1.000 EA
000640000P	TAG WINDING THERMOST	1.000 EA
000692000NG	LABEL ;NP 4POLE METRIC LABEL	1.000 EA
004824007K	SPECIAL PAINT	0.100 EA
034180020GA	KEY 1/2X1/2X2-1/2 L	1.000 EA
418018116	WARNING PLATE	1.000 EA

616002-001

INDUSTRIAL DIRECT CURRENT MOTORS AND GENERATORS - RPM III

ENCLOSURE: DRIP-PROOF FULLY-GUARDED,
SPLASHPROOF
MOUNTING: FOOT
METHOD OF DRIVE: COUPLED OR BELTED

COOLING: FORCE VENTILATED
WITH INTEGRAL
BLOWER AND MOTOR

FRAMES SC2113ATZ THRU LC2115ATZ

ACCESSORIES: PROVISION FOR
TACHOMETER MOUNTING
ONLY WHEN SPECIFIED

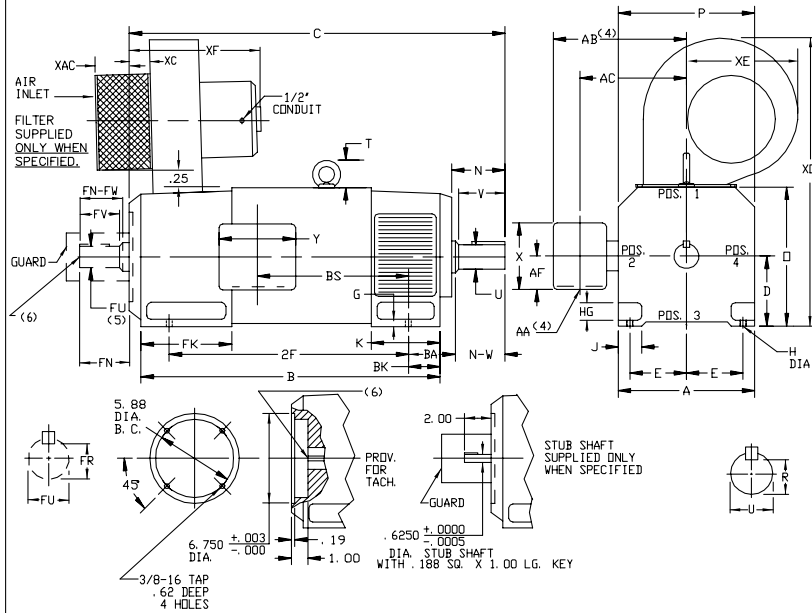

DIMENSIONS ARE IN INCHES

FRAME	XAC	XC	XE	XF	XO
SC2113ATZ-LC2115ATZ	7.75	2.25	10.00	16.00	22.75

FRAME	A	D(1)	E	G	H	HG	J	O	P	T	BA	K	FK	BK
SC2113ATZ-LC2115ATZ	10.25	5.25	4.25	.44	.44	1.38	1.75	10.44	10.31	2.08	3.50	5.19	6.81	2.38

FRAME	C(7)	B	BS	2F	DRIVE END SHAFT AND KEY							OPPOSITE DRIVE END SHAFT AND KEY(S)					WT. LBS.		
					N	N-W	U(2)	V	R(3)	SQ.	LGTH	FN	FN-FW	FU(2)	FV	FR(3)		SQ.	LGTH
SC2113ATZ	28.38	22.50	11.38	18.00	4.00	3.75	1.875	3.50	1.991	.500	2.50	3.50	3.25	1.625	3.00	1.416	.375	2.25	345
MC2113ATZ	29.62	23.75	12.62	18.00	4.00	3.75	1.875	3.50	1.991	.500	2.50	3.50	3.25	1.625	3.00	1.416	.375	2.25	370
LC2113ATZ	31.25	25.38	14.25	18.00	4.00	3.75	1.875	3.50	1.991	.500	2.50	3.50	3.25	1.625	3.00	1.416	.375	2.25	400
MC2115ATZ	32.50	26.62	15.50	22.00	4.00	3.75	1.875	3.50	1.991	.500	2.50	3.50	3.25	1.625	3.00	1.416	.375	2.25	425
LC2115ATZ	35.25	29.38	18.25	22.00	4.00	3.75	1.875	3.50	1.991	.500	2.50	3.50	3.25	1.625	3.00	1.416	.375	2.25	480

- (1) "D" DIMENSION WILL NOT BE EXCEEDED. SHIMS UP TO .03 INCHES IN THICKNESS ARE USUALLY REQUIRED FOR COUPLED OR GEARED MACHINES.
- (2) "U" AND "FU" VARY----+.000 - .001
- (3) "R" AND "FR" VARY----+.000 - .015
- (4) TERMINAL BOX VARIES WITH H.P. FOR DIMENSIONS "AA", "AB", "AC", "AF", "X" AND "Y". REFER TO BDX D/S. (STD. 609959-1, "X/P" 609959-2, MILL 609959-3)
- (5) OPPOSITE DRIVE END SHAFT SUPPLIED ONLY WHEN SPECIFIED.
- (6) MOTOR SHAFT TAPPED FOR SCREW-IN STUB SHAFT.
- (7) WHEN THE MOTOR APPLICATION DOES NOT REQUIRE THE USE OF OPP. DRIVE END, ADD .25 TO "C" DIM. FOR BRACKET COVER. TERMINAL BOX CAN BE ROTATED FOR LEAD OUTLET AT TOP, SIDES OR BOTTOM. OR C-1 MOUNTING IS SPECIFIED. BDX LOCATED ON TOP WHEN SPECIFIED. BLOWER ASSEMBLY CAN BE LOCATED AT POSITIONS 1, 2, OR 4, EXCEPT BLOWER ASSEMBLY AND TERMINAL BOX CAN NOT BE LOCATED AT THE SAME POSITION. MOTOR WEIGHT MAY VARY 15% FOR NON-STANDARD RATINGS AND/OR ACCESSORIES. IF MOUNTING CLEARANCE DETAILS ARE REQUIRED, CONSULT FACTORY.

CUSTOMER IS RESPONSIBLE FOR DETERMINING THAT BALDOR'S PRODUCT WILL PERFORM SUITABLY IN THE INTENDED APPLICATION.

REV. DESC: LOADED TO BUS	VERSION: 00	TDR: 000000578087
REV. LTR: -	REVISED: 08:22:49 01/28/2011	BY: CONNAS
FILE: \RGG\00015\944		
MTL: -		

BALDOR

DIMENSION DRAWING, SC2113ATZ - LC2115ATZ, DPP, FOOT MTG

SH 1 of 1

616002-001

609959-001

**INDUSTRIAL DIRECT CURRENT MOTORS
AND GENERATORS - RPM III**
TERMINAL BOX DIMENSIONS
STANDARD SIZE AND ONE SIZE LARGER
FRAMES C2113ATZ THRU C2815ATZ

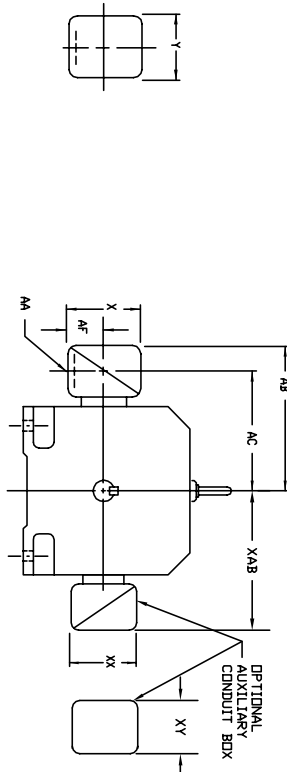

FRAME SIZE	STANDARD SIZE						ONE SIZE LARGER								
	MAX. AMPS	AK(1)	AB	AC	AF	PART NUMBER	AK(1)	AB	AC	AF	PART NUMBER				
C2113ATZ	40	3/4 & 1"	8.97	7.47	1.94	4.38	5.00	7.05029-1-R	1-1/4 & 1-1/2	10.03	8.03	2.50	5.50	6.12	705029-1-R
C2115ATZ	96	1-1/4 & 1-1/2	10.03	8.03	2.50	5.50	6.12	705029-1-R	2" & 2-1/2	11.16	8.41	3.19	7.00	7.62	705030-1-R
(2)	208	2" & 2-1/2	11.16	8.41	3.19	7.00	7.62	705030-1-R	2" & 2-1/2	11.16	8.41	3.19	7.00	7.62	705030-1-R
C2513ATZ	40	3/4 & 1"	10.03	8.53	1.94	4.38	5.00	705029-1-R	1-1/4 & 1-1/2	11.09	9.09	2.50	5.50	6.12	705029-1-R
C2515ATZ	96	1-1/4 & 1-1/2	11.09	9.09	2.50	5.50	6.12	705029-1-R	2" & 2-1/2	12.22	9.47	3.19	7.00	7.62	705030-1-R
(2)	208	2" & 2-1/2	12.22	9.47	3.19	7.00	7.62	705030-1-R	2" & 2-1/2	12.22	9.47	3.19	7.00	7.62	705030-1-R
C2813ATZ	128	2"	14.03	10.53	4.25	8.44	7.25	74874-R	3"	14.47	11.22	4.25	8.44	7.25	74874-R
C2815ATZ	185	3"	14.47	11.22	4.25	8.44	7.25	74874-R	4"	15.91	11.84	5.38	10.56	9.00	703038-3-R
(2)	259	4"	15.91	11.84	5.38	10.56	9.00	703038-3-R	5" (4)	18.72	13.47	7.00	12.75	15.00	702658-1-C

FRAME SIZE	STANDARD SIZE						ONE SIZE LARGER								
	MAX. AMPS	AK(3)	AB	AC	AF	PART NUMBER	AK(3)	AB	AC	AF	PART NUMBER				
C2113ATZ	18	3/4	10.03	8.03	2.50	5.00	5.75	705028-2-S	1"	10.03	8.03	2.50	5.00	5.75	705028-2-T
C2115ATZ	40	1"	10.03	8.03	2.50	5.00	5.75	705028-2-R	1-1/2	10.97	8.53	3.00	6.00	7.00	705029-2-S
(2)	96	1-1/2	10.97	8.53	3.00	6.00	7.00	705029-2-R	2-1/2	12.66	8.91	3.62	7.88	9.23	705029-2-S
C2513ATZ	18	3/4	10.97	8.53	3.00	6.00	5.75	705028-2-S	1"	11.09	9.09	2.50	5.00	5.75	705028-2-T
C2515ATZ	40	1"	11.09	9.09	2.50	5.00	5.75	705028-2-R	1-1/2	12.03	9.59	3.00	6.00	7.00	705029-2-R
(2)	96	1-1/2	12.03	9.59	3.00	6.00	7.00	705029-2-S	2-1/2	12.03	9.59	3.00	6.00	7.00	705029-2-S
C2813ATZ	128	2"	12.78	10.34	3.00	6.00	7.00	75460-T	3"	14.47	10.72	3.62	7.88	9.23	76700-R
C2815ATZ	185	3"	14.47	10.72	3.62	7.88	9.23	76700-R	4"	15.78	11.59	4.12	9.50	10.50	76700-R
(2)	259	4"	15.78	11.59	4.12	9.50	10.50	76700-R	5" (4)	18.59	13.34	7.00	12.75	15.00	76870-S

FRAME SIZE	STANDARD SIZE						ONE SIZE LARGER					
	AMP(S)	AB	AC	AF	X	Y	AB	AC	AF	X	Y	
C210	100	10.71	8.98	2.72	7.48	7.48	706310-56-A	7.48	706310-56-A	7.48	706310-225-R	
200	11.26	9.25	3.35	8.82	8.82	706310-56-B	8.82	706310-56-B	8.82	706310-225-R		
100	11.30	9.57	2.72	7.48	7.48	706310-56-A	7.48	706310-56-A	7.48	706310-225-R		
200	11.85	9.84	3.35	8.82	8.82	706310-56-B	8.82	706310-56-B	8.82	706310-225-R		
400	17.48	12.75	6.20	14.39	14.39	706310-63-B & 706310-63G	14.39	706310-63-B & 706310-63G	14.39	706310-63-B & 706310-63G		
800	17.48	12.75	6.20	14.39	14.39	706310-63-B & 706310-63G	14.39	706310-63-B & 706310-63G	14.39	706310-63-B & 706310-63G		
200	12.60	10.99	3.76	8.82	8.82	706310-56-B	8.82	706310-56-B	8.82	706310-226-R		
400	18.27	13.54	6.20	14.39	14.39	706310-63-B & 706310-63G	14.39	706310-63-B & 706310-63G	14.39	706310-63-B & 706310-63G		
800	18.27	13.54	6.20	14.39	14.39	706310-63-B & 706310-63G	14.39	706310-63-B & 706310-63G	14.39	706310-63-B & 706310-63G		
1600	18.27	13.54	7.68	15.35	15.35	706310-63-C	15.35	706310-63-C	15.35	706310-63-C		

FRAME SIZE	OPTIONAL AUXILIARY CONDUIT BOX DIMENSIONS (MAXIMUM)								
	XAB	XX	XY	Y	PART NUMBER	PART NUMBER			
C210	7.38	4.25	4.25	6.02007-26-A	C210	10.88	8.00	8.00	706310-3-B
C250	8.44	4.25	4.25	6.02007-26-A	C250	11.88	8.00	8.00	706310-3-B
C280	9.12	4.25	4.25	6.02007-26-A	C280	12.62	8.00	8.00	706310-3-B

(1) *AM. CONDUIT
(2) STEEL TERMINAL BOX FOR C2113ATZ AND C2513ATZ
(3) *AM. PIPE TAP
(4) TERMINAL BOX 76870-S AND 76870-9R EXTENDS BELOW MOTOR FEET.
TERMINAL BOX CAN BE ROTATED FOR LEAD DULLET AT TOP. SIDES OF BOTTOM TERMINAL BOX LOCATED ON OPPOSITE SIDE WHEN F-2, V-1, V-4, V-5, V-7, PR-C-1 MOUNTING IS SPECIFIED. BOX LOCATED ON TOP WHEN SPECIFIED.
FOR *X/P TERMINAL BOX DIMENSIONS SEE 609959-2.
FOR **X/P TERMINAL BOX DIMENSIONS SEE 609959-3.

CUSTOMER IS RESPONSIBLE FOR DETERMINING THAT BALDOR'S PRODUCT WILL PERFORM SUITABLY IN THE INTENDED APPLICATION.

REV. DESC: ADD 706310-63G C/BOX TO C250 AND C280 FRAMES	VERSION: 01	TDR: 000000816512
REV. LTR: A		
FILE: \RGG\00021\153		REVISED: 03:09:09 09/06/2013
MTL: -		BY: RGGWT



DIMENSION SHEET
SH 1 of 1

609959-001

406770-006

406770-006

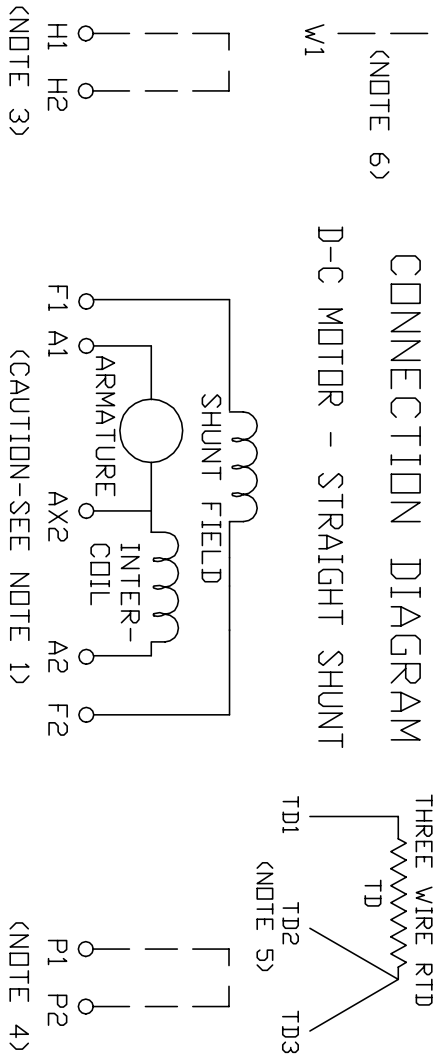

1. **CAUTION** — ARMATURE MAY HAVE MULTIPLE LEADS. CONNECT ALL LUGS WITH THE SAME MARKING TOGETHER.
2. OPTIONAL CONTROL SIGNAL LEAD IS MARKED AX2. ALWAYS TAKE INTERPOLE DROP BETWEEN A2 AND AX2. NOTE: NEMA DESIGNATION FOR AX2 IS LETTER C.
3. SPACE HEATERS, WHEN PROVIDED, WILL HAVE LEADS MARKED H1 AND H2, H3, H4, ETC.
4. THERMAL PROTECTOR, WHEN PROVIDED, WILL HAVE LEADS MARKED P1 AND P2, P3, P4, ETC.
5. WINDING RTD'S, WHEN PROVIDED, WILL HAVE LEADS MARKED TD1, TD2, & TD3.
6. BRUSH WEAR SENSOR, WHEN PROVIDED, WILL HAVE LEAD MARKED W1.
7. **WARNING** — MOTOR MUST BE GROUNDED TO PREVENT SERIOUS INJURIES TO PERSONNEL. GROUND THE MOTOR PER IEC, NATIONAL ELECTRICAL CODE AND ANY APPLICABLE LOCAL ELECTRICAL CODES. A TAPPED HOLE IS PROVIDED IN THE CONDUIT BOX, ON THE FOOT. FRAME BRACE OR OPPOSITE OPPOSITE DRIVE END BRACKET, ADJACENT TO THE TERMINAL BOX FOR MOTOR GROUNDING. GROUND LEAD, WHEN PROVIDED, WILL BE GREEN.

CUSTOMER _____ RELIANCE _____
 ORDER NO. _____ S.D. NO. _____

REV. DESC: UPDATE LOGO AND TITLEBLOCK: LOADED TO BUS		
REV. LTR: -	VERSION: 00	TDR: 000000781086
FILE: \RSN\00026\515	REVISED: 02: 41: 08 02/01/2013	
MTL: -	BY: MGHPC	

BALDOR

D-C MOTOR CONNECTION DIAGRAM, STRAIGHT SHUNT

SH 1 of 1