

BALDOR® • RELIANCE 

Product Information Packet

D5150R-BV

50HP, 1150RPM, DC, 2514ATZ, DPG-FV,

Part Detail							
Revision:	C	Status:	PRD/A	Change #:		Proprietary:	No
Type:	DC	Prod. Type:		Elec. Spec:	G8382A B	CD Diagram:	406770-006
Enclosure:	DP	Mfg Plant:		Mech. Spec:		Layout:	616012-001
Frame:	C2514	Mounting:	F2	Poles:	00	Created Date:	04-22-2015
Base:		Rotation:	R	Insulation:	F	Eff. Date:	10-21-2015
Field Type:		Literature:		Elec. Diagram:		Replaced By:	

Specs			
Enclosure:	DP		
Frame:	C2514ATZ		
Frame Material:	Exposed Laminations		
Agency Approvals:	CCSA US		
Base Indicator:	Rigid		
Bearing Grease Type:	Polyrex EM (-20F +300F)		
Drip Cover:	No Drip Cover		
Duty Rating:	CONT		
Feedback Device:	NO FEEDBACK		
Field Winding Type:	STR. SHUNT		
Frame Prefix:	C		
Heater Indicator:	No Heater		
Insulation Class:	F		
Lifting Lugs:	Standard Lifting Lugs		
Mounting Arrangement:	F2		
Shaft Extension Location:	Pulley End		

Shaft Ground Indicator:	No Shaft Grounding		
Shaft Slinger Indicator:	No Slinger		
Motor Standards:	NEMA		

Nameplate 000613006HP			
CAT.NO. D5150R-BV FR C2514ATZ ENCL. DP ENCL MOD FORCE VENT MAX SAFE SPEED	FIELD DATA WINDING STR. SHUNT VOLTS 300 MAX AMPS @ 25 C 4.06 HOT AMPS 3.11/1.55 BRUSH:419904051AC	SPEC NO. T25T1359 HP 50 RPM 1150/1935 VOLTS 500 AMPS 87.00 SER.NO.	DUTY CONT S.F. 1.0 INSUL F AMB. 40 POWER CODE C D.E. BRG. 65BC03J30X O.D.E. BRG. 50BC02J30X MIN. AMB. 0 TYPE TR

Parts List		
Part Number	Description	Quantity
SA299491	SA T25T1359	1.000 EA
AA016275	AA T25T1359	1.000 EA
000692000FP	NP, WARNING LIFT INSTRUCTIONS	1.000 EA
000692000FS	WARNING LABEL	1.000 EA
418057747A	METAL FASTENER	8.000 EA
000613006HP	NAMEPLATE - RPM III D-C MOTOR W/CSA LOGO	1.000 EA
036600008AB	MFWSH M6 PLATED	1.000 EA
419905008A	HARDWARE	8.000 EA
036000020KB	MHHCS M10-1.5X20MM PLTD.	4.000 EA
036610010AB	MHSLW M10 PLATED	4.000 EA
036501008AB	KPNUT M6-1.0 ZINCPLTED	8.000 EA
419905003A	FLAT WASHER ROCKER RPM III RGG	4.000 EA
036000012HB	HHCS M6X12MM LONG PLATED	4.000 EA
419904-51AC	BRUSH EXTRUDER DUTY C	4.000 EA
706372011RE	ROCKR METRIC	1.000 EA
706364051RCA	BRHLD METRIC SPRING CHG.	4.000 EA
801926102C	BRKT,ODE,C250	1.000 EA
801927102A	BRKT,DE,C250	1.000 EA
004824015A	GREASE POLYREX EM	0.200 LB
036000055JB	HHCS,DE CAP	2.000 EA
400638001AD	WAVEN - 400	1.000 EA
418150003A	GREASE FITTING CAP	2.000 EA
035000001A	ALFTG 1/8" 1610-BL	1.000 EA
035000001BB	GREASE FTG,GRS.IN	1.000 EA

Parts List (continued)		
Part Number	Description	Quantity
036100070KA	METRIC HSHCS	3.000 EA
034693001AB	PPLG - G508- use 034692001AB	1.000 EA
034693001AB	PPLG - G508- use 034692001AB	1.000 EA
036500010AB	METRIC NUT M10-1.5PLTD400	4.000 EA
609830005AAV	TBOLT .375" X 19.50"	4.000 EA
036500010AB	METRIC NUT M10-1.5PLTD400	4.000 EA
610490001AH	.75HP,3450//2850RPM,3PH,60//50HZ,56C,351	1.000 EA
415000103G	TLUG	1.000 EA
036000012JB	M8-1.25 X 12MM HXHDC	3.000 EA
611965001A	WHEEL, BLOWER	1.000 EA
417733001D	GASKT	2.000 EA
611917002C	GASKT	1.000 EA
036000020JB	HHCS M8-1.25X20L PLTD-250	4.000 EA
032018006CK	HHCS 3/8-16X3/4L PLATED	4.000 EA
000613006NT	NAME PLATE IEC	1.000 EA
036600009AB	METRIC FLWASH M8 PLATED	3.000 EA
418018074A	GROUND LABEL G100 METRIC 160 D.C.	1.000 EA
708528004C	HOUSING, BLOWER	1.000 EA
410978010C	FLANGE, INLET BLOWER HSG.	1.000 EA
410978019A	SCREEN, INLET FLANGE	1.000 EA
036620009AB	M8 EXTERNAL LK WASHER	1.000 EA
034017014AB	LCKW 3/8 STD. PLATED	4.000 EA
418010006A	CAST,MPLATE,180-280,EX1,7BY	1.000 EA
032018004CK	HHCS 3/8-16X1/2L PLATED	4.000 EA

Product Information Packet: D5150R-BV - 50HP,1150RPM,DC,2514ATZ,DPG-FV,

422919027	HHCVR KIT, C250, ODE, SOLID	1.000 EA
422919029	HHCVR KIT, C250, DE, LOUVERED	1.000 EA
422919029	HHCVR KIT, C250, DE, LOUVERED	1.000 EA
422919038	HHCVR KIT C250 ODE SOLID	1.000 EA
706320005A	CONDUIT BOX	1.000 EA
075453000A	CBOXC, PAINTED 250-280	1.000 EA
065564000B	GASK 250-280	1.000 EA
422919038	HHCVR KIT C250 ODE SOLID	1.000 EA
422919038	HHCVR KIT C250 ODE SOLID	1.000 EA
036000012HB	HHCS M6X12MM LONG PLATED	2.000 EA
036000045JB	M8-1.25 X 45MM HXHCS	4.000 EA
406770006	C/D TAG STRAIGHT SHUNT	1.000 EA
706305026A	GUARD,SHAFT	1.000 EA
034180028HA	KEY 5/8X5/8X3-1/2L-445	1.000 EA
000640000P	TAG WINDING THERMOST	1.000 EA
000692000NG	LABEL ;NP 4POLE METRIC LABEL	1.000 EA
004824007K	SPECIAL PAINT	0.100 EA
418018116	WARNING PLATE	1.000 EA

616012-001

INDUSTRIAL DIRECT CURRENT MOTORS AND GENERATORS - RPM III

ENCLOSURE: DRIP-PROOF FULLY-GUARDED, SPLASHPROOF
 COOLING: FORCE VENTILATED WITH INTEGRAL BLOWER AND MOTOR
 MOUNTING: FOOT
 METHOD OF DRIVE: COUPLED OR BELTED
 ACCESSORIES: PROVISION FOR TACHOMETER MOUNTING ONLY WHEN SPECIFIED
 FRAMES SC2512ATZ THRU UC2515ATZ

DIMENSIONS ARE IN INCHES

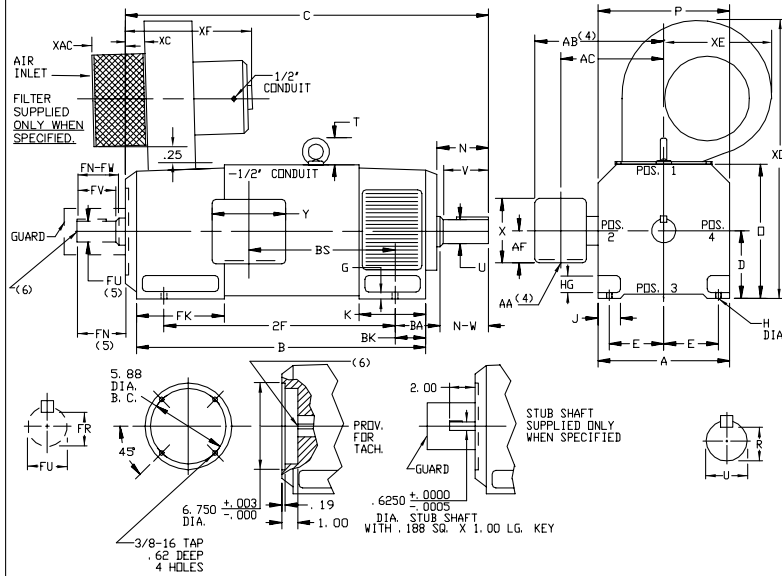

FRAME		XAC	XC	XE	XF	XO
SC2512ATZ-UC2515ATZ		7.25	3.00	9.50	16.75	24.75

FRAME	A	B(1)	E	G	H	HG	J	O	P	T	BA	K	FK	BK
SC2512ATZ-UC2515ATZ	12.31	6.25	5.00	.50	.56	1.62	2.00	12.50	12.44	2.44	4.25	6.06	8.00	3.00

FRAME	METHOD OF DRIVE	C(7)	B	BS	2F	N	N-W	UC(2)	V	RC(3)	SG	LGTH	FN	FN-FW	FU(2)	FV	FR(3)	SD	LGTH	WT. LBS.
SC2512ATZ	COUPLED	31.69	25.06	12.06	20.00	4.50	4.25	2.125	4.00	1.845	.500	3.00	4.00	3.75	1.875	3.50	1.591	.500	2.50	535
MC2512ATZ	COUPLED	33.19	26.56	13.56	20.00	4.50	4.25	2.125	4.00	1.845	.500	3.00	4.00	3.75	1.875	3.50	1.591	.500	2.50	570
LC2512ATZ	COUPLED	34.69	28.06	15.06	20.00	4.50	4.25	2.125	4.00	1.845	.500	3.00	4.00	3.75	1.875	3.50	1.591	.500	2.50	610
CC2514ATZ	COUPLED	38.44	31.31	18.31	25.00	5.00	4.75	2.375	4.50	2.021	.625	3.50	4.00	3.75	1.875	3.50	1.591	.500	2.50	695
CC2515ATZ	COUPLED	42.44	35.31	22.31	28.00	5.00	4.75	2.375	4.50	2.021	.625	3.50	4.00	3.75	1.875	3.50	1.591	.500	2.50	805
UC2514ATZ	BELTED	38.44	31.31	18.31	25.00	5.00	4.75	2.375	4.50	2.021	.625	3.50	4.00	3.75	1.875	3.50	1.591	.500	2.50	695
UC2515ATZ	BELTED	42.44	35.31	22.31	28.00	5.00	4.75	2.375	4.50	2.021	.625	3.50	4.00	3.75	1.875	3.50	1.591	.500	2.50	805

- (1) "B" DIMENSION WILL NOT BE EXCEEDED. SHIMS UP TO .03 INCHES IN THICKNESS ARE USUALLY REQUIRED FOR COUPLED OR GEARED MACHINES.
 - (2) "U" AND "FU" VARY---4.000 - .001
 - (3) "R" AND "FR" VARY---4.000 - .015
 - (4) TERMINAL BOX VARIES WITH H.P. FOR DIMENSIONS "AA", "AB", "AC", "AF", "X" AND "Y". REFER TO BOX D/S. (STD. 609959-1, "X/P" 609959-2, MILL 609959-3)
 - (5) OPPOSITE DRIVE END SHAFT SUPPLIED ONLY WHEN SPECIFIED.
 - (6) MOTOR SHAFT TAPPED FOR SCREW-IN STUB SHAFT.
 - (7) WHEN THE MOTOR APPLICATION DOES NOT REQUIRE THE USE OF DPP, DRIVE END, ADD .25 TO "C" DIM. FOR BRACKET COVER.
- TERMINAL BOX LOCATED ON OPPOSITE SIDE WHEN F-2, W-1, V-4, V-5, W-7, OR C-1 MOUNTING IS SPECIFIED. BOX LOCATED ON TOP WHEN SPECIFIED.
 BLOWER ASSEMBLY CAN BE LOCATED AT POSITIONS 1, 2, OR 4, EXCEPT BLOWER ASSEMBLY AND TERMINAL BOX CAN NOT BE LOCATED AT THE SAME POSITION.
 MOTOR WEIGHT MAY VARY 15% FOR NON-STANDARD RATINGS AND/OR ACCESSORIES.
 IF MOUNTING CLEARANCE DETAILS ARE REQUIRED, CONSULT FACTORY.

CUSTOMER IS RESPONSIBLE FOR DETERMINING THAT BALDOR'S PRODUCT WILL PERFORM SUITABLY IN THE INTENDED APPLICATION.

REV. DESC: LOADED TO BUS	VERSION: 00	TDR: 000000578087
REV. LTR: -	REVISED: 11:06:09 01/28/2011	BY: CONNAS
FILE: \RGG\00015\979		
MTL: -		

BALDOR
 DIMENSION DRAWING, SC2512ATZ - UC2515ATZ, DPP, FOOT MTG
 SH 1 of 1

616012-001

609959-001

**INDUSTRIAL DIRECT CURRENT MOTORS
AND GENERATORS - RPM III**
TERMINAL BOX DIMENSIONS
STANDARD SIZE AND ONE SIZE LARGER
FRAMES C2113ATZ THRU C2815ATZ

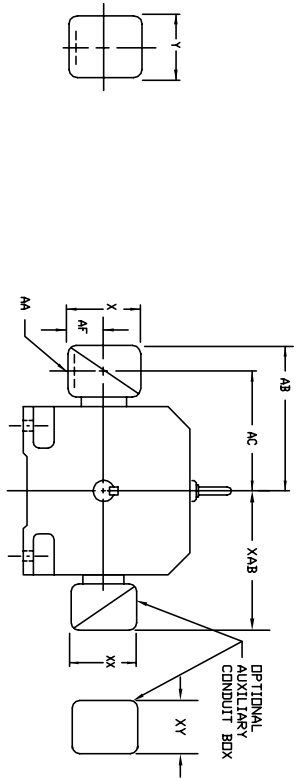

DIMENSIONS ARE IN INCHES

FRAME SIZE	STANDARD SIZE						ONE SIZE LARGER								
	MAX. AMPS	AK(1)	AB	AC	AF	PART NUMBER	AK(1)	AB	AC	AF	PART NUMBER				
C2113ATZ	40	3/4 & 1"	8.97	7.47	1.94	4.38	5.00	7.05029-1-R	1-1/4 & 1-1/2	10.03	8.03	2.50	5.00	6.12	7.05029-1-R
C2115ATZ	96	1-1/4 & 1-1/2	10.03	8.03	2.50	5.00	6.12	7.05029-1-R	2" & 2-1/2	11.16	8.41	3.19	7.00	7.62	7.05030-1-R
(2)	40	3/4 & 2-1/2	11.16	8.41	3.19	7.00	7.62	7.05030-1-R	2" & 2-1/2	11.16	8.41	3.19	7.00	7.62	7.05030-1-R
C2514ATZ	40	3/4 & 1"	10.03	8.53	1.94	4.38	5.00	7.05029-1-R	1-1/4 & 1-1/2	11.09	9.09	2.50	5.00	6.12	7.05029-1-R
C2515ATZ	96	1-1/4 & 1-1/2	11.09	9.09	2.50	5.00	6.12	7.05029-1-R	2" & 2-1/2	12.22	9.47	3.19	7.00	7.62	7.05030-1-R
(2)	208	2" & 2-1/2	12.22	9.47	3.19	7.00	7.62	7.05030-1-R	2" & 2-1/2	12.22	9.47	3.19	7.00	7.62	7.05030-1-R
C2815ATZ	128	2"	14.03	10.53	4.25	8.44	7.25	7.4874-R	3"	14.47	11.22	4.25	8.44	7.25	7.4874-R
C2815ATZ	155	3"	14.47	11.22	4.25	8.44	7.25	7.4874-R	4"	15.91	11.84	5.38	10.56	9.00	7.0308-3-R
C2815ATZ	259	4"	15.91	11.84	5.38	10.56	9.00	7.0308-3-R	5" (4)	18.72	13.47	7.00	12.75	15.00	7.02658-1-C

FRAME SIZE	STANDARD SIZE						ONE SIZE LARGER								
	MAX. AMPS	AK(3)	AB	AC	AF	PART NUMBER	AK(3)	AB	AC	AF	PART NUMBER				
C2113ATZ	18	3/4	10.03	8.03	2.50	5.00	5.75	7.05028-2-S	1"	10.03	8.03	2.50	5.00	5.75	7.05028-2-T
C2115ATZ	40	1"	10.03	8.03	2.50	5.00	5.75	7.05028-2-R	1-1/2	10.97	8.53	3.00	6.00	7.00	7.05029-2-S
(2)	96	1-1/2	10.97	8.53	3.00	6.00	7.00	7.05029-2-R	2-1/2	12.66	8.91	3.62	7.88	9.23	7.05029-2-S
208	3/4	10.97	8.53	3.00	6.00	7.00	7.05029-2-S	1"	11.09	9.09	2.50	5.00	5.75	7.05028-2-T	
C2514ATZ	40	1"	11.09	9.09	2.50	5.00	5.75	7.05028-2-T	1-1/2	12.03	9.59	3.00	6.00	7.00	7.05029-2-R
C2515ATZ	96	1-1/2	12.03	9.59	3.00	6.00	7.00	7.05029-2-S	2"	12.03	9.59	3.00	6.00	7.00	7.05029-2-S
(2)	208	2"	12.03	9.59	3.00	6.00	7.00	7.05029-2-S	1-1/2	12.03	9.59	3.00	6.00	7.00	7.05029-2-S
C2815ATZ	128	2"	12.78	10.34	3.00	6.00	7.00	7.5460-T	3"	14.47	10.72	3.62	7.88	9.23	7.6700-R
C2815ATZ	155	3"	14.47	10.72	3.62	7.88	9.23	7.6700-R	4"	15.78	11.59	4.12	9.50	10.50	7.6700-R
C2815ATZ	259	4"	15.78	11.59	4.12	9.50	10.50	7.6700-R	5" (4)	18.59	13.34	7.00	12.75	15.00	7.6870-S

FRAME SIZE	STANDARD SIZE						ONE SIZE LARGER					
	AMP'S	AB	AC	AF	X	Y	AB	AC	AF	X	Y	
C210	100	10.71	8.98	2.72	7.48	7.48	7.48	7.48	7.48	7.48	7.48	
200	11.26	9.25	3.35	8.82	8.82	8.82	8.82	8.82	8.82	8.82	8.82	
400	11.80	9.57	2.72	7.48	7.48	7.48	7.48	7.48	7.48	7.48	7.48	
800	11.85	9.84	3.35	8.82	8.82	8.82	8.82	8.82	8.82	8.82	8.82	
C290	400	17.48	12.75	6.20	14.39	14.39	14.39	14.39	14.39	14.39	14.39	
800	17.48	12.75	6.20	14.39	14.39	14.39	14.39	14.39	14.39	14.39	14.39	
400	12.60	10.99	3.76	8.82	8.82	8.82	8.82	8.82	8.82	8.82	8.82	
800	18.27	13.54	6.20	14.39	14.39	14.39	14.39	14.39	14.39	14.39	14.39	
1600	18.27	13.54	6.20	14.39	14.39	14.39	14.39	14.39	14.39	14.39	14.39	

(1) "AA" CONDUIT TERMINAL BOX FOR C2113ATZ AND C2514ATZ
 (2) STEEL TERMINAL BOX WITH DOUBLE KNOCKOUT.
 (3) "AM" PIPE TAP.
 (4) TERMINAL BOX 76870-9R EXTENDS BELOW MOTOR FEET. TERMINAL BOX CAN BE ROTATED FOR LEAD OFFSET AT TOP, SIDES OR BOTTOM. TERMINAL BOX LOCATED ON OPPOSITE SIDE WHEN F-2, V-1, V-4, V-5, V-7, OR C-1 MOUNTING IS SPECIFIED. BOX LOCATED ON TOP WHEN SPECIFIED. FOR "XY" TERMINAL BOX DIMENSIONS SEE 609959-2. FOR "XYP" TERMINAL BOX DIMENSIONS SEE 609959-3.

CUSTOMER IS RESPONSIBLE FOR DETERMINING THAT BALDOR'S PRODUCT WILL PERFORM SUITABLY IN THE INTENDED APPLICATION.

REV. DESC: ADD 706310-63G C/BOX TO C250 AND C280 FRAMES	VERSION: 01	TDR: 000000816512
REV. LTR: A	FILE: \RGG\00021\153	REVISED: 03:09:09 09/06/2013
MTL: -		BY: RGGWT

BALDOR
 DIMENSION SHEET
 SH 1 of 1

609959-001

406770-006

406770-006

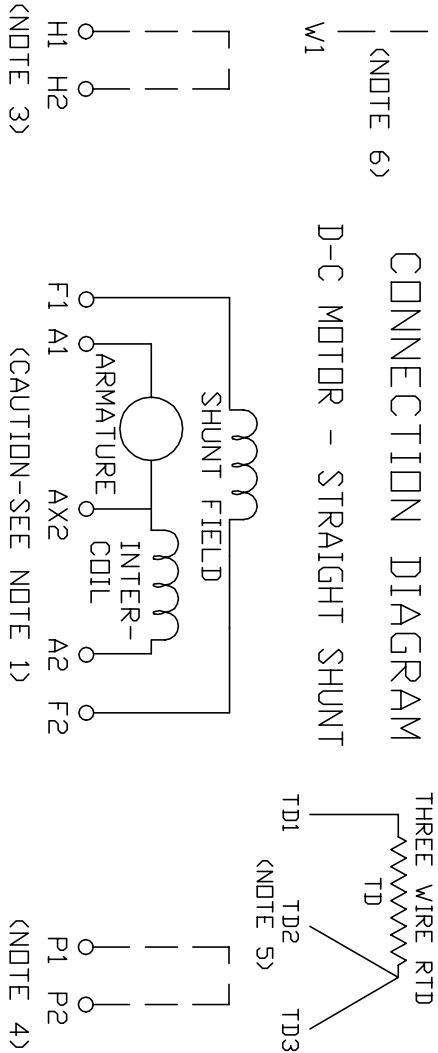

ROTATION FACING COMMUTATOR END

ARMATURE AND FIELD EXTERNAL CONNECTIONS
WARNING- SEE NOTE 7 FOR GROUNDING INSTRUCTIONS

1. **CAUTION** — ARMATURE MAY HAVE MULTIPLE LEADS. CONNECT ALL LUGS WITH THE SAME MARKING TOGETHER.
2. OPTIONAL CONTROL SIGNAL LEAD IS MARKED AX2. ALWAYS TAKE INTERPOLE DROP BETWEEN A2 AND AX2. NOTE: NEMA DESIGNATION FOR AX2 IS LETTER C.
3. SPACE HEATERS, WHEN PROVIDED, WILL HAVE LEADS MARKED H1 AND H2, H3, H4, ETC.
4. THERMAL PROTECTOR, WHEN PROVIDED, WILL HAVE LEADS MARKED P1 AND P2, P3, P4, ETC.
5. WINDING RTD'S, WHEN PROVIDED, WILL HAVE LEADS MARKED TD1, TD2, & TD3.
6. BRUSH WEAR SENSOR, WHEN PROVIDED, WILL HAVE LEAD MARKED W1.
7. **WARNING** — MOTOR MUST BE GROUNDED TO PREVENT SERIOUS INJURIES TO PERSONNEL. GROUND THE MOTOR PER IEC, NATIONAL ELECTRICAL CODE AND ANY APPLICABLE LOCAL ELECTRICAL CODES. A TAPPED HOLE IS PROVIDED IN THE CONDUIT BOX, ON THE FOOT. FRAME BRACE OR OPPOSITE OPPOSITE DRIVE END BRACKET, ADJACENT TO THE TERMINAL BOX FOR FOR MOTOR GROUNDING. GROUND LEAD, WHEN PROVIDED, WILL BE GREEN.

CUSTOMER _____ RELIANCE _____
ORDER NO. _____ S.D. NO. _____

REV. DESC: UPDATE LOGO AND TITLEBLOCK: LOADED TO BUS		
REV. LTR: -	VERSION: 00	TDR: 000000781086
FILE: \RSN\00026\515	REVISED: 02: 41: 08 02/01/2013	
MTL: -	BY: MGHPC	

BALDOR

D-C MOTOR CONNECTION DIAGRAM, STRAIGHT SHUNT

SH 1 of 1

Marketing maintained PDF of MN602:

<http://www.baldor.com/support/Literature/Load.ashx/MN602?ManNumber=MN602>