

BALDOR® • RELIANCE 

Product Information Packet

D5520P

20HP, 1750/2300RPM, DC, 328AT, TEFC, F1

Part Detail							
Revision:	E	Status:	PRD/A	Change #:		Proprietary:	No
Type:	DC	Prod. Type:		Elec. Spec:		CD Diagram:	
Enclosure:		Mfg Plant:		Mech. Spec:		Layout:	885-4
Frame:		Mounting:	F1	Poles:	00	Created Date:	04-09-2015
Base:		Rotation:	R	Insulation:		Eff. Date:	10-28-2016
Field Type:		Literature:		Elec. Diagram:		Replaced By:	

Specs			
Frame:	328AT		
Frame Material:	Steel		
Agency Approvals:	CSA		
Base Indicator:	Rigid		
Bearing Grease Type:	Polyrex EM (-20F +300F)		
Drip Cover:	No Drip Cover		
Feedback Device:	NO FEEDBACK		
Heater Indicator:	No Heater		
Insulation Class:	F		
Lifting Lugs:	Standard Lifting Lugs		
Mounting Arrangement:	F1		
Shaft Extension Location:	Pulley End		
Shaft Ground Indicator:	No Shaft Grounding		
Shaft Slinger Indicator:	No Slinger		
Motor Standards:	NEMA		

Nameplate NP1734										
CAT.NO.	D5520P			MODEL	T32R8008					
HP	20	RPM	1750/ 2300		FRAME	0328AT				
ARM V	500	ARM A	32.70		WOUND	STR. SHUNT				
FLD V	150/ 300	FLD A	2.22-1.30/1.11-.65							
CONN		OHMS				CL	F			
ENCL	TEFC	DUTY	CONT			MX AMB	40			
P CODE	D	CTSR				SER.F.	1.0			
S/N				E/S	K0083A A					
O.D.E. BRG.	6210	D.E. BRG.	6211		BRUSH	28610-7				
									QTY	2

Parts List		
Part Number	Description	Quantity
SA297042	SA T32R8008	1.000 EA
AA016093	AA T32R8008	1.000 EA
NP1734	NPL,BALDOR DC MTR ALUMINUM	1.000 EA
15209	LABEL CONNECTIONS & TERMINAL MARKIN	1.000 EA
435360008	MWIRE 4 GA 004824-004BV	45.000 LB
15555-994	KEY 1/2 SQ	1.000 EA
32016-1	ROTOR WASHER, FR 329, SPL W/409 SLOT LAM	1.000 EA
32016-1	ROTOR WASHER, FR 329, SPL W/409 SLOT LAM	1.000 EA
32659	COMM HUB MACH-FR328, 1 OR 2 BR	1.000 EA
611956007A	(018) BANDSHELF 320	1.000 EA
15094	DISHED LOCKWASHER .332 ID, .865 OD	2.000 EA
32024-1	FAN MACH,STD,320 SERIES INTERNAL FAN	1.000 EA
609848007A	NOMEX WASHER, ROUND DC 2POLE ODE	1.000 EA
HA1086	BALANCING RING FOR 320 FRAME	2.000 EA
032018018DK	HHCS 1/2-13X2-1/4 PLTD.	4.000 EA
032018018DK	HHCS 1/2-13X2-1/4 PLTD.	4.000 EA
046001026J	THERM N/C S06-145	1.000 EA
32035-1	INTERPOLE STACK	2.000 EA
424504013DF	FT. MILL 320 SHIM PACK	1.000 EA
424508251A	ROUND 328 DC FRAME INSUL BM	1.000 EA
032018040DK	HHCS 1/2-13X5L PLATED	4.000 EA
035000001A	ALFTG 1/8" 1610-BL	1.000 EA
15033-11	WASHER WAVE SPR #042 ASSOC. SPR. #W3917-	1.000 EA
32029-10	FE BRKT,STD. LOCKED C/E 320AT	1.000 EA

Parts List (continued)		
Part Number	Description	Quantity
HW4500A17	317400 ALEMITE GREASE RELIEF	1.000 EA
15599-37	DRIVE SCR,#10 X.37 TYPE UPLATED STEEL	6.000 EA
004824015A	GREASE POLYREX EM	0.400 LB
032130010DA	1/2-13 X 1.25 HSHCS	4.000 EA
032130016BA	HSHCS OUTER CAP LE	4.000 EA
15185-6	LUBE EXTENSION 3.06 LENGTH	1.000 EA
15185-7	LUBE EXTENSION 4.00" LONG	1.000 EA
15548-2	LUB FITTING,PRESS-IN ALEMITE #1743-B/EQ	1.000 EA
15548-3	GREASE RELIEF,PRESS-IN ALEMITE #321381/E	1.000 EA
32031-5	CE BRKT MACH FR 320 FOR LOCKED C.E	1.000 EA
HA4048A01	DRIVE-IN PLUG,.50"EXPAN.PLUG,	2.000 EA
032018004BK	HHCS 5/16-18X1/2 PLATED	2.000 EA
15094	DISHED LOCKWASHER .332 ID, .865 OD	2.000 EA
28610-7	BRUSH,280/320FR.IM9101MORGANITE/619HELWI	2.000 EA
BP5228R01	BR ROCKER ASSY,FR 28 & 32 SINGLE BRUSH	1.000 EA
032018004AK	HHCS 1/4-20X1/2 PLATED	2.000 EA
032018004BK	HHCS 5/16-18X1/2 PLATED	28.000 EA
032018006CK	HHCS 3/8-16X3/4L PLATED	4.000 EA
032018006DK	HHCS 1/2-13X3/4 PLATED	4.000 EA
032018004BK	HHCS 5/16-18X1/2 PLATED	3.000 EA
032018010DK	HHCS 1/2-13X1-1/4 PLATED	4.000 EA
032620032KB	HSSS 1/4-20X1" PLTD - 360	4.000 EA
033100012AB	1/4-20 HX MACH SCREW NUT	4.000 EA
15021-2	ACC.FACE SCR.N,1/2 #13/15 FLTND. EXP.META	1.000 EA

Product Information Packet: D5520P - 20HP,1750/2300RPM,DC,328AT,TEFC,F1

15024-4	TERM.BOX CVR. FR-28,32,36DUREX P/N:D618	1.000 EA
15024-5	GASKET, T.BOX COVER	1.000 EA
15024-6	TERM.BOX BASE FR-320, DUREX P/N:3SP	1.000 EA
15024-7	GASKET,T/BOX FR. 280/3201/8" THK.,MUELL	2.000 EA
150449-31	GRD STUD ARG .312DIA STUD	1.000 EA
15115	TERM BOX HOLE COVER FRAME 280 & 320	1.000 EA
15442	COVER RING TEFC ACC FACE #14 GA CR	1.000 EA
15555-150	KEY .500/.498 SQ	1.000 EA
32019-1	ACCESS COVER FRAME 32 SERIES #14 GA STE	3.000 EA
32019-2	ACCESS COVER FRAME 32 SERIES	3.000 EA
32020-1	GASKET, COVER, FAN END	3.000 EA
32020-2	GASKET COVER COM END FRAME 320 SERIES	3.000 EA
32023-2	SOLID SMILE COVER, FR 320	1.000 EA
32051-1	FAN MACH FR 320ALUM ALUMINUM	1.000 EA
32055	C-FACE COVER MACH FR 32 SERIES TEFC	1.000 EA
32555	SHROUD & GUARD ASSY FR 320 ASSY	1.000 EA
80XN3816A06	3/8-16 X 3/8 SET SCREW	2.000 EA
MG1025G05	WILKOFEST, 789.227, MED. GRAY CHAR. MET.	0.200 GA
034180025GA	KEY,DE	1.000 EA
PA1100	PACK FOR #1 SKID; CUSTOM	1.000 EA
MG5047	VARNISH 004824-001HM	0.200 GA
041009029G	#4 BUTT CONNECTOR	3.000 EA
041009038F	INT. LEAD LUG	4.000 EA
482413015Y	#15 SLVG	6.000 FT
482413004Y	#4 SLEEVING (GREEN) PER FT	6.000 FT

Accessories		
Part Number	Description	Multiplier
94EP5000A01	C-FACE CONVERSION KIT STOCK MTR,FR 320	

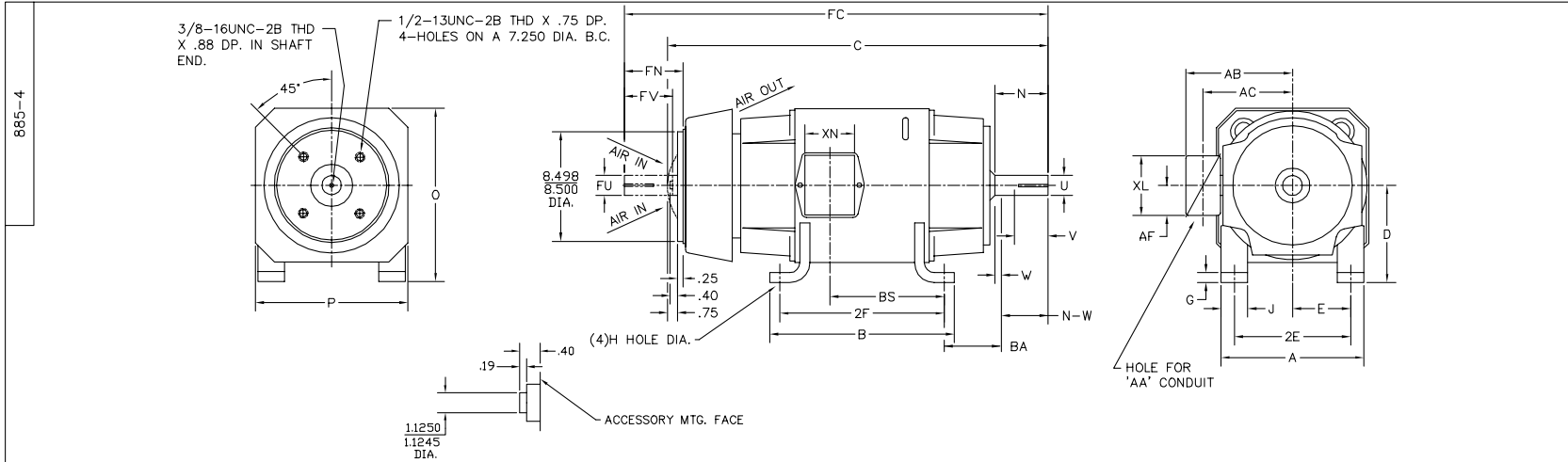

FRAME	FOOT MOUNTING						D.E. SHAFT EXTENSION						DRIVE KEY		ACC SHAFT EXTENSION			ACC KEY		FRAME					
	BA	E	2F	G	H	J	N	N-W	U	V	W	KEY-SQ.	KEY-LONG	FN	FU	FV	KEY-SQ.	KEY-LONG	A	B	C	FC	D	O	P
327AT	5.25	6.25	14.00	.81	.656	3.00	4.40	4.25	2.125	4.00 ³	.15	.500	3.12	3.94	1.875	3.69	.500	2.81	15.88	15.75	37.06	40.57	8.00 ²	15.94	15.88
328AT	5.25	6.25	16.00	.81	.656	3.00	4.40	4.25	2.125	4.00 ³	.15	.500	3.12	3.94	1.875	3.69	.500	2.81	15.88	17.75	38.94	42.45	8.00 ²	15.94	15.88
329AT	5.25	6.25	18.00	.81	.656	3.00	4.40	4.25	2.125	4.00 ³	.15	.500	3.12	3.94	1.875	3.69	.500	2.81	15.88	19.75	40.94	44.45	8.00 ²	15.94	15.88
365AT	5.88	7.00	12.25	.81	.813	3.25	4.94	4.75	2.375	4.50 ³	.19	.625	3.50	4.62	2.125	4.37	.500	3.13	17.75	13.75	37.91	42.62	9.00 ²	17.94	17.88
366AT	5.88	7.00	14.00	.81	.813	3.25	4.94	4.75	2.375	4.50 ³	.19	.625	3.50	4.62	2.125	4.37	.500	3.13	17.75	15.50	40.10	44.81	9.00 ²	17.94	17.88
368AT	5.88	7.00	18.00	.81	.813	3.25	4.94	4.75	2.375	4.50 ³	.19	.625	3.50	4.62	2.125	4.37	.500	3.13	17.75	19.50	43.10	47.81	9.00 ²	17.94	17.88
3610AT	5.88	7.00	22.00	.81	.813	3.25	4.94	4.75	2.375	4.50 ³	.19	.625	3.50	4.62	2.125	4.37	.500	3.13	17.75	23.50	46.10	50.81	9.00 ²	17.94	17.88
3612AT	5.88	7.00	28.00	.81	.813	3.25	4.94	4.75	2.375	4.50 ³	.19	.625	3.50	4.62	2.125	4.37	.500	3.13	17.75	29.50	49.10	53.81	9.00 ²	17.94	17.88

FRAME	CONDUIT BOX							ARM APPROX. WK ² LBS.FT. ²	APPROXIMATE WEIGHT
	AA	AB	AC	AF	BS	XL	XN		
327AT	2	12.94	10.32	5.00	11.81	7.88	5.25	8.45	760 ⁵
328AT	2	12.94	10.32	5.00	13.68	7.88	5.25	9.67	835 ⁵
329AT	2	12.94	10.32	5.00	15.68	7.88	5.25	10.97	944 ⁵
365AT	2 1/2	14.06	11.38	5.00	9.06	7.88	5.25	15.61	865 ⁵
366AT	2 1/2	14.06	11.38	5.00	11.25	7.88	5.25	18.27	975 ⁵
368AT	2 1/2	14.06	11.38	5.00	14.25	7.88	5.25	22.21	1135 ⁵
3610AT	3	16.86	13.09	6.53	18.25	11.63	7.76	28.00	1213 ⁵
3612AT	3	16.86	13.09	6.53	24.25	11.63	7.76	31.60	1552 ⁵

- 1) SHAFT DIAMETERS TO 1.500 TOLERANCE +.0000 -.0005
 SHAFT DIAMETERS ABOVE 1.500 TOLERANCE +.0000 -.0010
 SHAFT DIAMETERS TO 1.625 RUNOUT .002 T.I.R. MAX.
 SHAFT DIAMETERS ABOVE 1.625 RUNOUT .003 T.I.R. MAX.
- 2) 'D' DIMENSION TOLERANCE +.000 -.000
- 3) 'V' DIMENSION IS MAX HUB LENGTH ON SHAFT
- 4) CONDUIT BOX CAN BE ROTATED IN 90° STEPS ON ITS OWN AXIS.
- 5) TOTAL WEIGHT OF MOTOR AND FAN COOLED PACKAGE.
- 6) ALL DIMENSIONS NOT NOTED ARE NOMINAL DIMENSIONS CONSULT FACTORY FOR TOLERANCES.

FOR F1 OR F2 CONDUIT BOX LOCATION SEE SALES ORDER

CUSTOMER IS RESPONSIBLE FOR DETERMINING THAT BALDOR'S PRODUCT WILL PERFORM SUITABLY IN THE INTENDED APPLICATION.

REV. DESC: 885-4 RESCALE DRAWING IN BUS	VERSION: 02	TDR: 000000763880
REV. LTR: C	REVISED: 09:37:55 09/07/2012	BY: RGGWT
FILE: \RGG\00019\544		
MTL: -		

BALDOR
 DIM SHEET
 SH 1 of 1

885-4

885-4

Marketing maintained PDF of MN605:

<http://www.baldor.com/support/Literature/Load.ashx/MN605?ManNumber=MN605>