

SUPPLIER: PARKER (DIXON) P/N: 1111 TH: DCP25 1/4

DCPXXX

CUSTOMER DWG

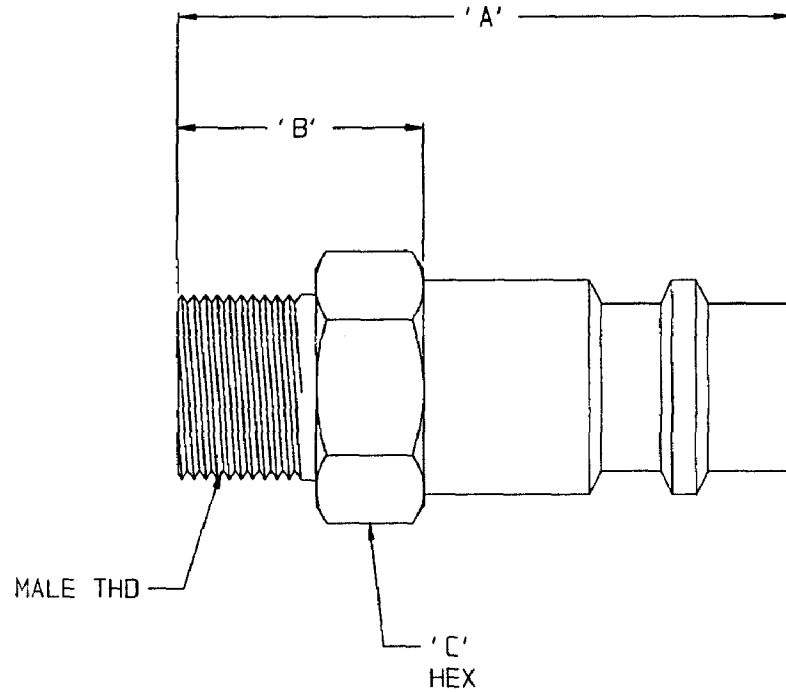

NOTE:

- ALL PART NUMBERS ENDING IN B ARE BRASS, ALL OTHERS ARE STEEL.

AGREEMENT TO MAINTAIN CONFIDENTIALITY

This drawing is owned by Dixon Valve & Coupling Co. and shall be returned upon demand. It is loaned on condition that it shall not be copied or reproduced or submitted to others without the owners consent. In accepting it subject to this condition the recipient further agrees that this drawing or any design detail or concept disclosed herein shall not be used in any way detrimental to or in competition with the Owner. If the recipient does not agree to the terms of this agreement, they shall return this drawing immediately.



The Right Connection™

SIZE PLUG	PART NO	'A'	'B'	'C'	THD
1/2"	DCP1706	2 9/16"	1 3/16"	1 1/16"	3/8" NPT
1/2"	DCP17	2 1/2"	1 1/16"	7/8"	1/2" NPT
1/2"	DCP1703	2 5/16"	15/16"	11/16"	3/8" NPT
3/8"	DCP2504	2 1/8"	1 1/16"	7/8"	1/2" NPT
3/8"	DCP25	1 7/8"	13/16"	11/16"	3/8" NPT
3/8"	DCP2502	1 7/8"	7/8"	5/8"	1/4" NPT
1/4"	DCP2103 DCP2103B	1 13/16"	7/8"	11/16"	3/8" NPT
1/4"	DCP21 DCP21B	1 3/4"	13/16"	9/16"	1/4" NPT
1/4"	DCP2101 DCP2101B	1 9/16"	5/8"	1/2"	1/8" NPT
SIZE PLUG	PART NO	'A'	'B'	'C'	THD

CUSTOMER DWG

DIXON VALVE & COUPLING CO.
U. S. A.

TITLE 'AIR CHEIF' QUICK CONNECT FITTINGS
PLUGS WITH MALE THD

DRAWN BY: 9/20/96 ANDREW JINKS
CHECKED BY: 12-13 96
APPROVAL: *[Signature]*

MAT'L SEE NOTE

DCPXXX