

DATE
May 21, 2007

CATALOG NO.
DHP0756R-50

OUTLINE DIMENSIONS
3-PHASE INDUCTION MOTOR

MOTOR TYPE:
ASHH

FRAME NO. 405T

Pole	HP	KW	Hz	VOLT	Syn. Speed RPM
6	75	56	50	190/380	1000

Ins	Rating	Dimension in	Approx Weight	Bearings
F	CONT.	inches	1058 lbs.	DE: NU317 NDE: 6317

Open Protected Drip-Proof Type, Squirrel-cage Rotor.

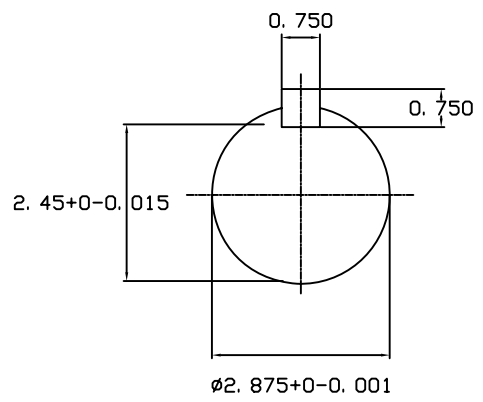
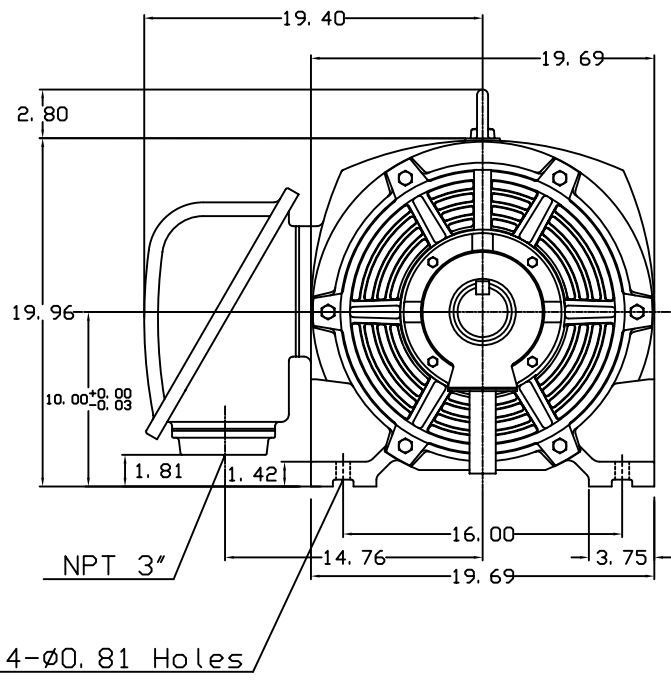
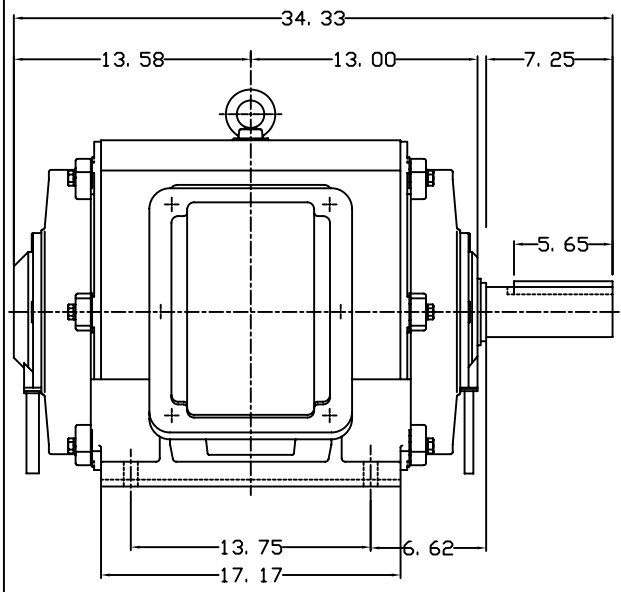

DWN.	J. H. LIANG	12-22-98
CHKD.	C. H. KAO	06-10-99
APPD.	Y. B. HUANG	06-10-99



DWG NO.
31057H400000