

TYPE	OUTPUT		POLE	TIME RATING	VOLTAGE V	Hz	SYN SPEED R.P.M
	HP.	KW.					
ASHH	150	112	4	CDNT.	460	60	1800

DRIP PROOF TYPE, SQUIRREL-CAGE ROTOR

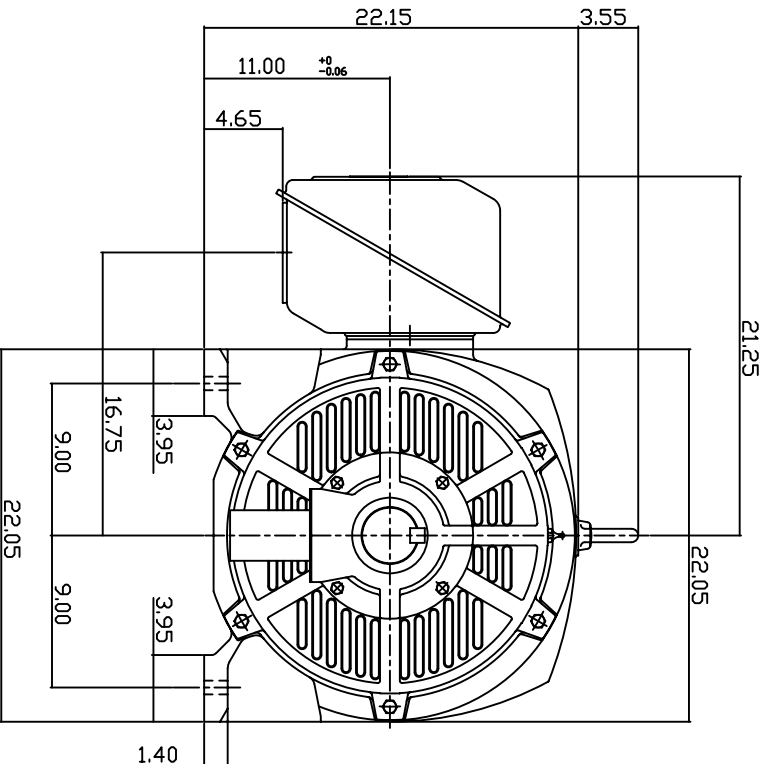
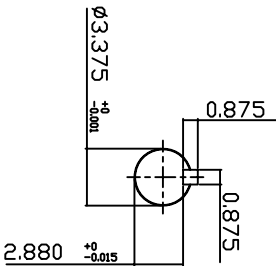
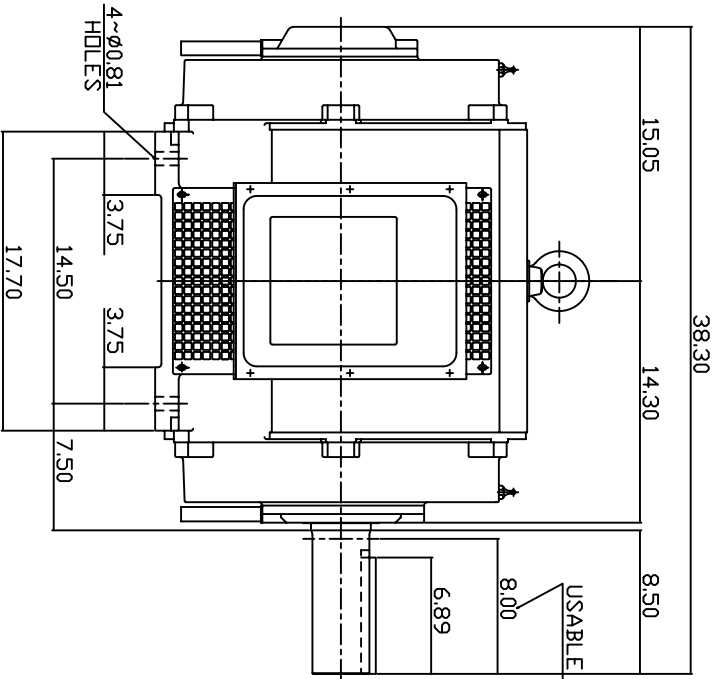

NOTE:

1. DIMENSIONS IN INCH.
2. FRAME NO.444T
3. F CLASS INSULATION, S.F. 115
4. FOR BELT DRIVE APPLICATIONS
5. BEARING SIZE: DRIVE END: NU318  
NON-DRIVE END: 6316
6. MOTOR APPROX. WEIGHT: 1320 LBS

TB-56SC

DWN.	W.LLIN	MAR. 26. 2003
CHKD.	W.LLIN	MAR. 26. 2003
APPD.	C.WANG	MAR. 26. 2003

DATE	May 14 2007	OUTLINE DIMENSIONS
CATALOG NO.	DHPI504R	
3-PHASE INDUCTION MOTOR		DWG NO.
TEC Westinghouse		3A040T259-1
		REV: 00