

TYPE	OUTPUT		POLE	TIME RATING	VOLTAGE V	Hz	SYN.SPEED R.P.M
	HP.	kW.					
AEHE	700	522	2	CONT.	460	60	3600

TOTALLY ENCLOSED FAN-COOLED TYPE, SQUIRREL-CAGE ROTOR

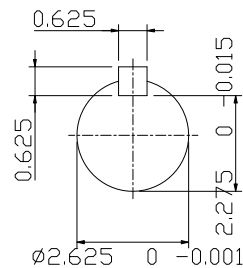
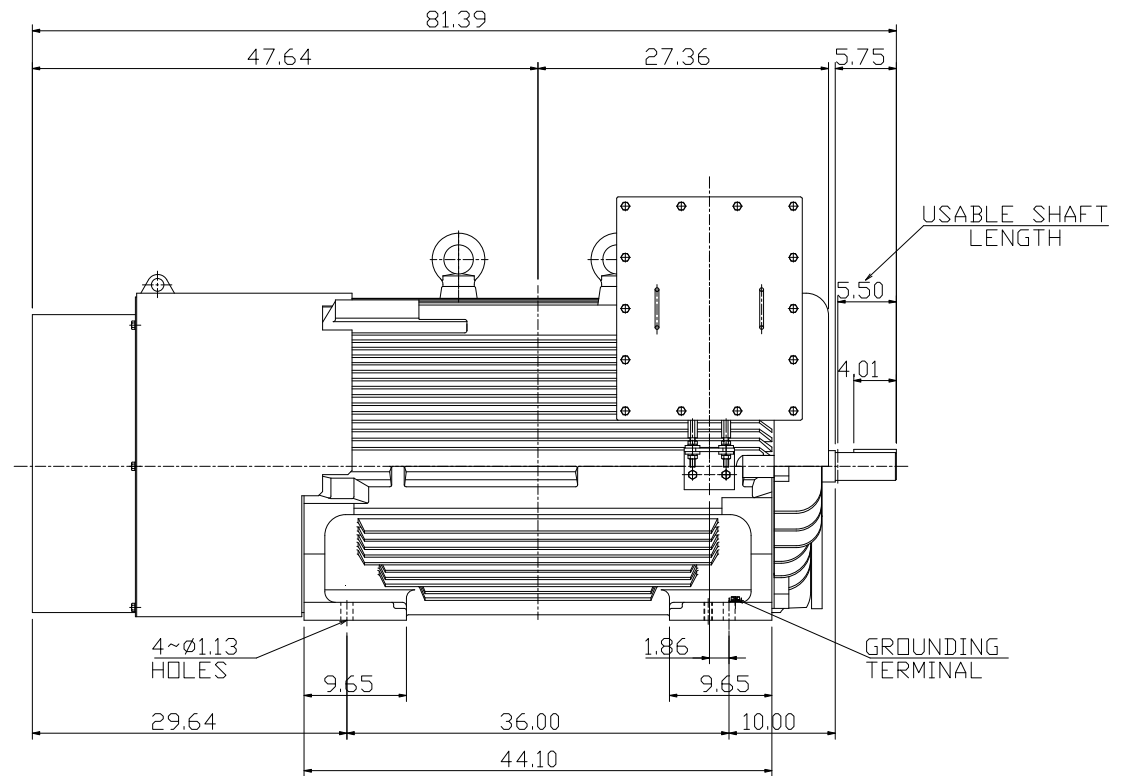
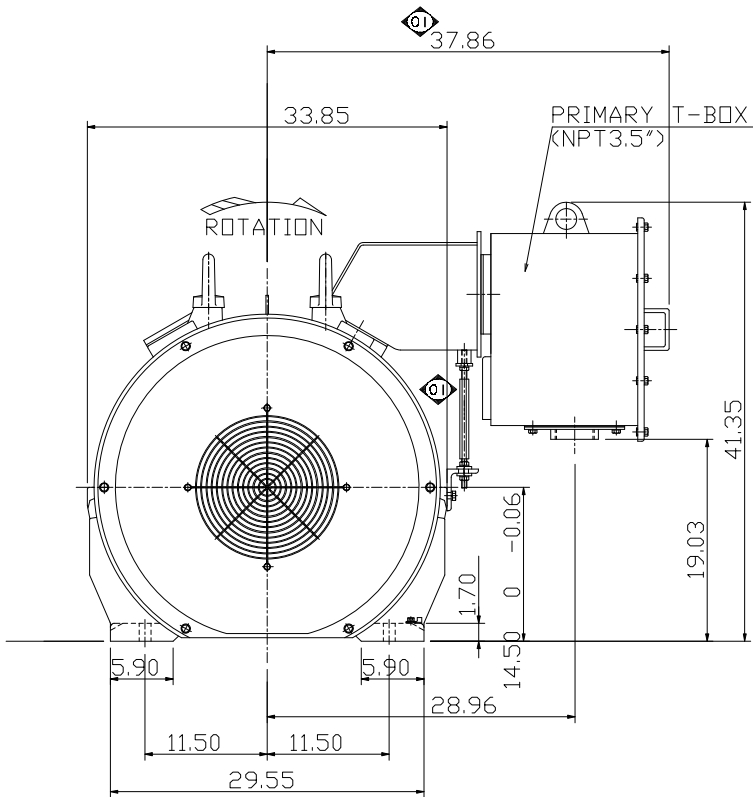

SHAFT END
(ENLARGED VIEW)

NOTE:

1. DIMENSIONS IN INCH
2. FRAME NO. 5810A
3. F CLASS INSULATION, S.F.115
4. FOR DIRECT FLEXIBLE COUPLING
5. ENCLOSURE: IP55
6. BEARING SIZE: DRIVE-END 6315C3
OPP. DRIVE-END 6315C3M/C3 VLD241
7. MOTOR APPROX. WEIGHT: 6600LBS

DATE	March 12, 2015	OUTLINE DIMENSIONS
Catalog #	E7002	
TECO Westinghouse		DWG NO. REV: 01 4A040G951

DWN.	Y.DU	AUG. 30. 2011
CHKD.	H.HUANG	AUG. 30. 2011
APPD.	B.LIN	AUG. 30. 2011