

BALDOR® • RELIANCE 

Product Information Packet

ECP4400TS-4

100HP, 1785RPM, 3PH, 60HZ, 405TS, A40064M, TEF

Part Detail							
Revision:	H	Status:	PRD/A	Change #:		Proprietary:	No
Type:	AC	Elec. Spec:	A40WG0066	CD Diagram:	416820-036	Mfg Plant:	
Mech. Spec:		Layout:	617429-502	Poles:	04	Created Date:	07-15-2013
Base:		Eff. Date:	10-16-2017	Leads:	3#2		

Specs			
Catalog Number:	ECP4400TS-4	Heater Indicator:	No Heater
Enclosure:	TEFC	Insulation Class:	F
Frame:	405TS	Inverter Code:	Inverter Ready
Frame Material:	Iron	KVA Code:	G
Output @ Frequency:	100.000 HP @ 60 HZ	Lifting Lugs:	Standard Lifting Lugs
Synchronous Speed @ Frequency:	1800 RPM @ 60 HZ	Motor Lead Quantity/Wire Size:	3 @ 2 AWG
Voltage @ Frequency:	460.0 V @ 60 HZ	Motor Type:	A40064M
XP Class and Group:	None	Mounting Arrangement:	F1
XP Division:	Division II	Power Factor:	87
Agency Approvals:	CSA EEV	Pulley End Bearing Type:	Ball
Auxillary Box:	No Auxillary Box	Pulley Face Code:	Standard
Base Indicator:	Rigid	Shaft Ground Indicator:	No Shaft Grounding
Bearing Grease Type:	Polyrex EM (-20F +300F)	Shaft Rotation:	Reversible
Constant Torque Speed Range:	10-60	Shaft Slinger Indicator:	Shaft Slinger
Current @ Voltage:	112.000 A @ 460.0 V	Speed Code:	Single Speed
Design Code:	B	Motor Standards:	NEMA
Drip Cover:	No Drip Cover	Starting Method:	Direct on line
Duty Rating:	CONT	Thermal Device - Bearing:	NONE (OLD)

Feedback Device:	NO FEEDBACK	Thermal Device - Winding:	None
		XP Temp Code:	T2D

Nameplate NP3238									
CAT NO	ECP4400TS-4	SPEC NO.	P40G3904						
HP	100	AMPS	112	VOLTS	460	DESIGN	B		
FRAME	405TS	RPM	1785	HZ	60	AMB	40	SF	1.15
D.E. BRG.DATA	6313	O.D.E. BRG.DATA	6313	PH	3	DUTY	CONT	INSUL.CLASS	F
D.E. BRG.	65BC03J30X	TYPE	P	ENCL	TEFC	CODE	G	NEMA NOM EFFICIENCY	95.4
O.D.E. BRG.	65BC03J30X	POWER FACTOR	87	MAX CORR KVAR	18.0	GUARANTEED EFFICIENCY	94.5		
3/4 LOAD EFF.	95.7	TEMP	= 215						
TEMP CODE	T2D	CT HZ	10-60	VT HZ	0-60				
CHP HZ	60-90								
INVERTER-TEMP-CODE	T2D								
SER.NO.		MOTOR WEIGHT							

Parts List		
Part Number	Description	Quantity
SA267695	SA P40G3904	1.000 EA
RA254365	RA P40G3904	1.000 EA
NP3238	SS CP XEX SEVERE DUTY MAIN NP	1.000 EA
000692000VD	LABEL WARNING	1.000 EA
000692000FF	N/P	1.000 EA
004824015A	GREASE POLYREX EM	0.884 LB
032018008CK	HHCS 3/8-16X1L PLATED	4.000 EA
032018020EK	HHCS 5/8-11X2-1/2 PLTD.	4.000 EA
032018024CK	HHCS 3/8-16X3 PLTD.	3.000 EA
034000014AB	WSH ID.406 OD.812 TH.065	4.000 EA
034180008DA	KEY 1/4X1/4X1 L (shipping)	1.000 EA
034530052AB	P/NIP 1/8X6-1/2 GALV.	1.000 EA
034530056BB	P/NIP 1/4X7 SCHED 40	1.000 EA
034631002AB	BUSH 1/4 TO 1/8 PLTD.	1.000 EA
078548001R	FAN KB 234/150 (84) 400	1.000 EA
034692005AA	P PLUG 3/4"BLK.	1.000 EA
083198101A	G400 STD FAN COVER MACHINING	1.000 EA
089413501A	G400 FIN/MACH FT MTD BRKT 089413500WCA	1.000 EA
410700000DA	WAVY SPRING WASHER	1.000 EA
415045002B	SLGR	1.000 EA
415072001B	CLAMP	1.000 EA
415096002A	CPLG 1/8 HEX TYPE	1.000 EA
032018020EK	HHCS 5/8-11X2-1/2 PLTD.	4.000 EA
032018024CK	HHCS 3/8-16X3 PLTD.	3.000 EA

Parts List (continued)		
Part Number	Description	Quantity
034530040AB	P/NIP 1/8X5 GALV.	1.000 EA
034530040BB	P/NIP 1/4X5	1.000 EA
034631002AB	BUSH 1/4 TO 1/8 PLTD.	1.000 EA
089413501A	G400 FIN/MACH FT MTD BRKT 089413500WCA	1.000 EA
415045002B	SLGR	1.000 EA
415096002A	CPLG 1/8 HEX TYPE	1.000 EA
032018010CK	HHCS 3/8-16X1-1/4 PLTD.	4.000 EA
033512008LB	HHTTS 1/4-20X1 PLATED	4.000 EA
034000014AB	WSH ID.406 OD.812 TH.065	4.000 EA
035000001A	ALFTG 1/8" 1610-BL	1.000 EA
035000001A	ALFTG 1/8" 1610-BL	1.000 EA
065776000C	TERBD 320-400	1.000 EA
067053000B	GASK 320-400	1.000 EA
076708000BB	C/B - 360	1.000 EA
076709000A	C/B Cover - 360	1.000 EA
406099000A	PLUG - FAN COVER 320-440	1.000 EA
415000103H	415000103H	1.000 EA
418150003A	GREASE FITTING CAP	1.000 EA
418150003A	GREASE FITTING CAP	1.000 EA
033775004EA	DRSCR #6-1/4 304 S.S.	4.000 EA
034180022GA	KEY 1/2X1/2X2-3/4 L	1.000 EA
MG1025N19	WILKO 778.50 BLUE GREEN - 55 GAL DRUMS	0.375 GA
004824003CBY	WILKO PAINT 060.02 - ACTIVATOR	0.063 GA
421948051	LABEL, MYLAR	1.000 EA

Product Information Packet: ECP4400TS-4 - 100HP,1785RPM,3PH,60HZ,405TS,A40064M,TEF

PK5004A02	WOOD BASE 40X32 STACK 2X4 RUNNER	1.000 EA
000613006PU	N/P (RELEASE QTY 10,000) UL CSA LABEL	1.000 EA
LB1449	DIV-2/NEC WARNING LABEL	1.000 EA
035000001G	GREASE RELIEF FITTING, ALEMITE 317400	1.000 EA
035000001G	GREASE RELIEF FITTING, ALEMITE 317400	1.000 EA
032018005DL	1/2-13 X 5/8 SILICON BRONZE HHCS	1.000 EA
412118006A	DRAIN	2.000 EA

REL. S.O.	FRAME	HP	TYPE	PHASE/HERTZ	RPM	VOLTS
	405TS	100	P	3/60	1785	460
AMPS	DUTY	AMB °C/ INSUL.	S.F.	NEMA DESIGN	CODE LETTER	ENCL.
112	CONT	40/F	1.15	B	G	TEFC
E/S	ROTOR	TEST S.O.	TEST DATE	STATOR RES. @25 °C (OHMS (BETWEEN LINES))		
596909	418142-33-RE	---	---	.0492		

PERFORMANCE

LOAD	HP	AMPERES	RPM	POWER FACTOR %	EFFICIENCY %
NO LOAD	0	28.7	1800	5.48	0
1/4	25.0	39.2	1796	64.3	93.0
2/4	50.0	59.4	1792	82.6	95.4
3/4	75.0	84.4	1788	86.9	95.7
4/4	100	112	1783	87.6	95.4
5/4	125	141	1778	87.4	94.9

SPEED TORQUE

	RPM	TORQUE % FULL LOAD	TORQUE LB.-FT.	AMPERES
LOCKED ROTOR	0	151	445	725
PULL UP	360	136	400	706
BREAKDOWN	1721	250	735	382
FULL LOAD	1783	100	295	112

AMPERES SHOWN FOR 460. VOLT CONNECTION. IF OTHER VOLTAGE CONNECTIONS ARE AVAILABLE, THE AMPERES WILL VARY INVERSELY WITH THE RATED VOLTAGE

REMARKS: TYPICAL DATA
 XE MOTOR-DATA-NEMA NOM. EFF. 95.4 PCT
 GURANTEED MIN EFF. 95.0 PCT

BALDOR	DR. BY J.J. HARRISON	A-C MOTOR
	CK. BY W.I. SMITH	
	APP. BY W.I. SMITH	PERFORMANCE DATA
	DATE 02/05/09	ISSUE DATE 12/15/10

REL. S.O. _____ RPM 1785 S.F. 1.15 ROTOR 418142-33-RE
 FRAME 405TS VOLTS 460 NEMA DESIGN B TEST S.O. TYPICAL DATA
 HP 100 AMPS 112 CODE LETTER G TEST DATE ---
 TYPE P DUTY CONT ENCLOSURE TEFPC STATOR RES. @ 25 °C .0492
 PHASE/HERTZ 3/60 AMB °C/INSUL 40/F E/S 596909 OHMS (BETWEEN LINES)

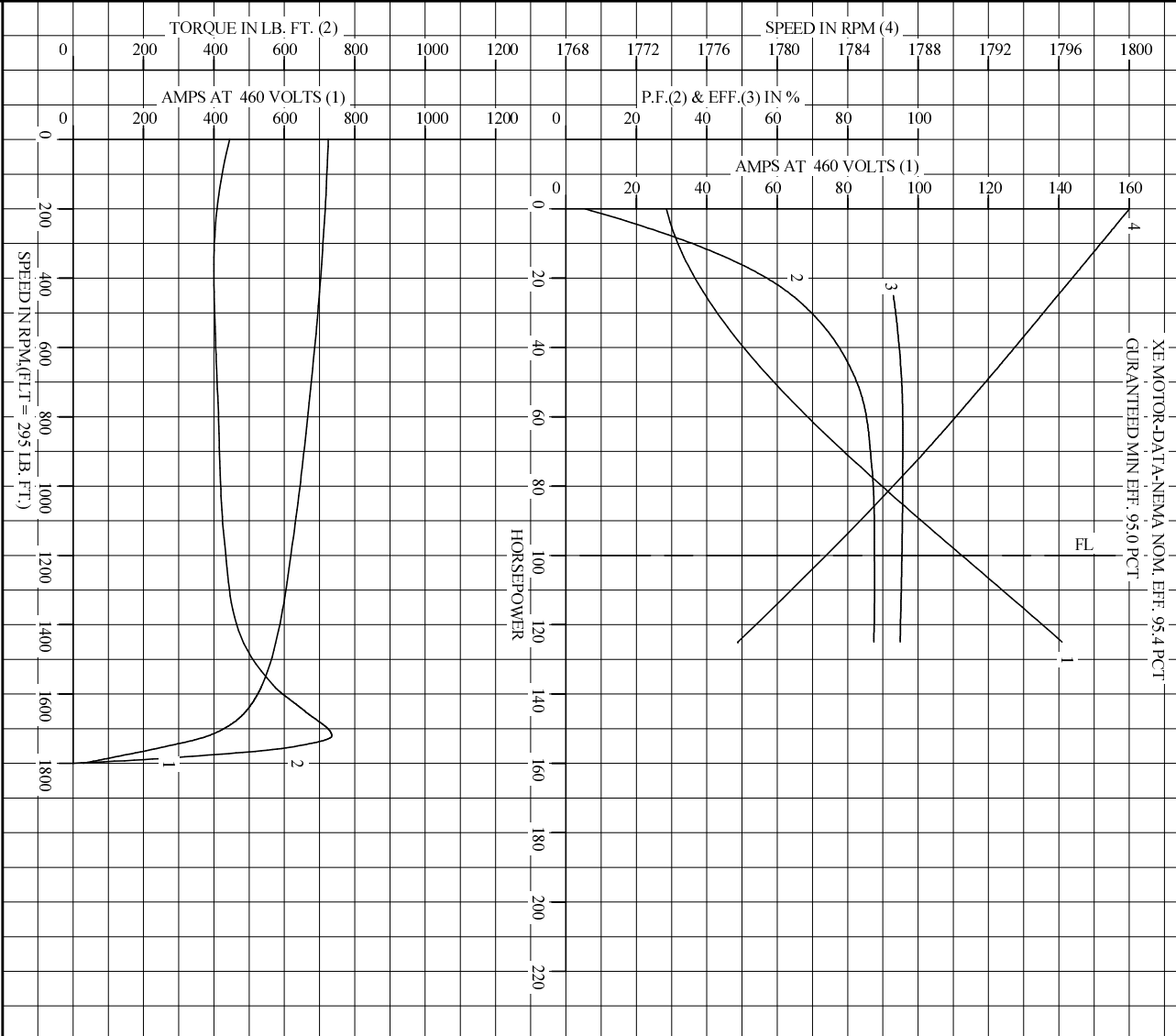

AMPERES SHOWN FOR 460 VOLT CONNECTION, IF OTHER VOLTAGE CONNECTIONS ARE AVAILABLE, THE AMPERES WILL VARY INVERSELY WITH THE RATED VOLTAGE.

BALDOR

DR. BY J.HARRISON
 CK. BY W.L.SMITH
 App. BY W.L.SMITH
 DATE 02/05/09

A-C MOTOR PERFORMANCE CURVES A400W/G0066-R002
 ISSUE DATE 12/15/10

Printed on 12/15/10 12:49 @ psecs-motorengr

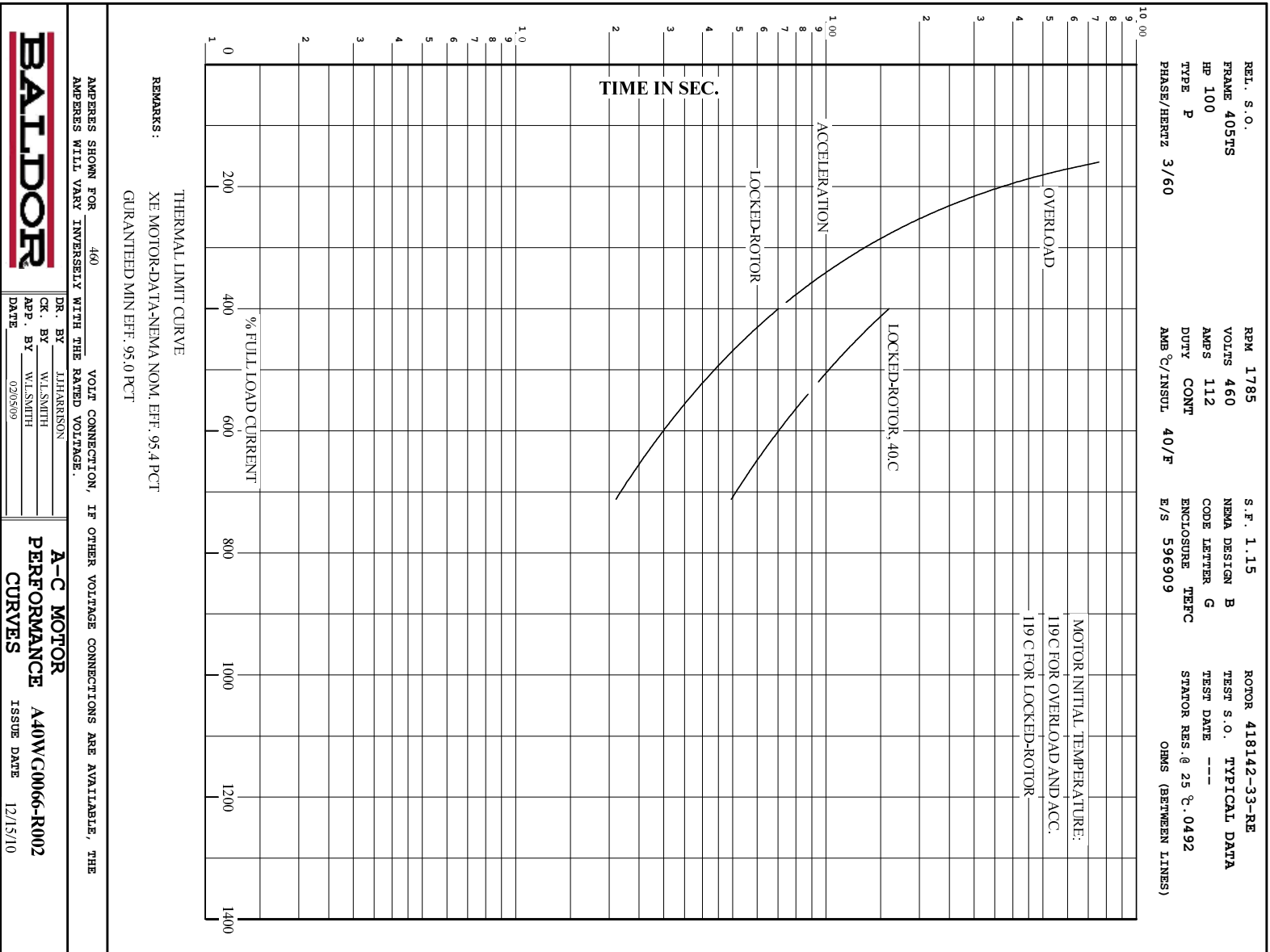

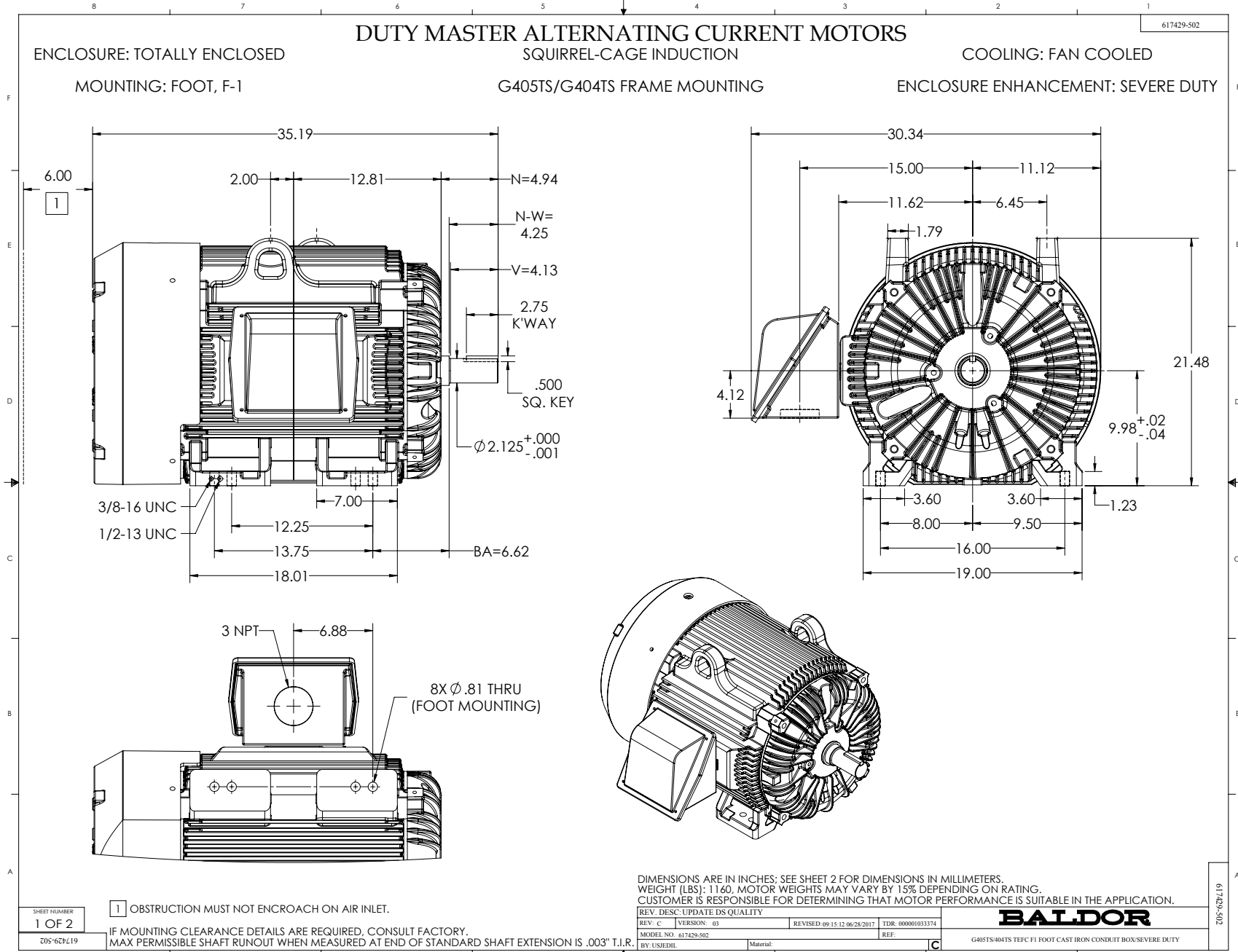

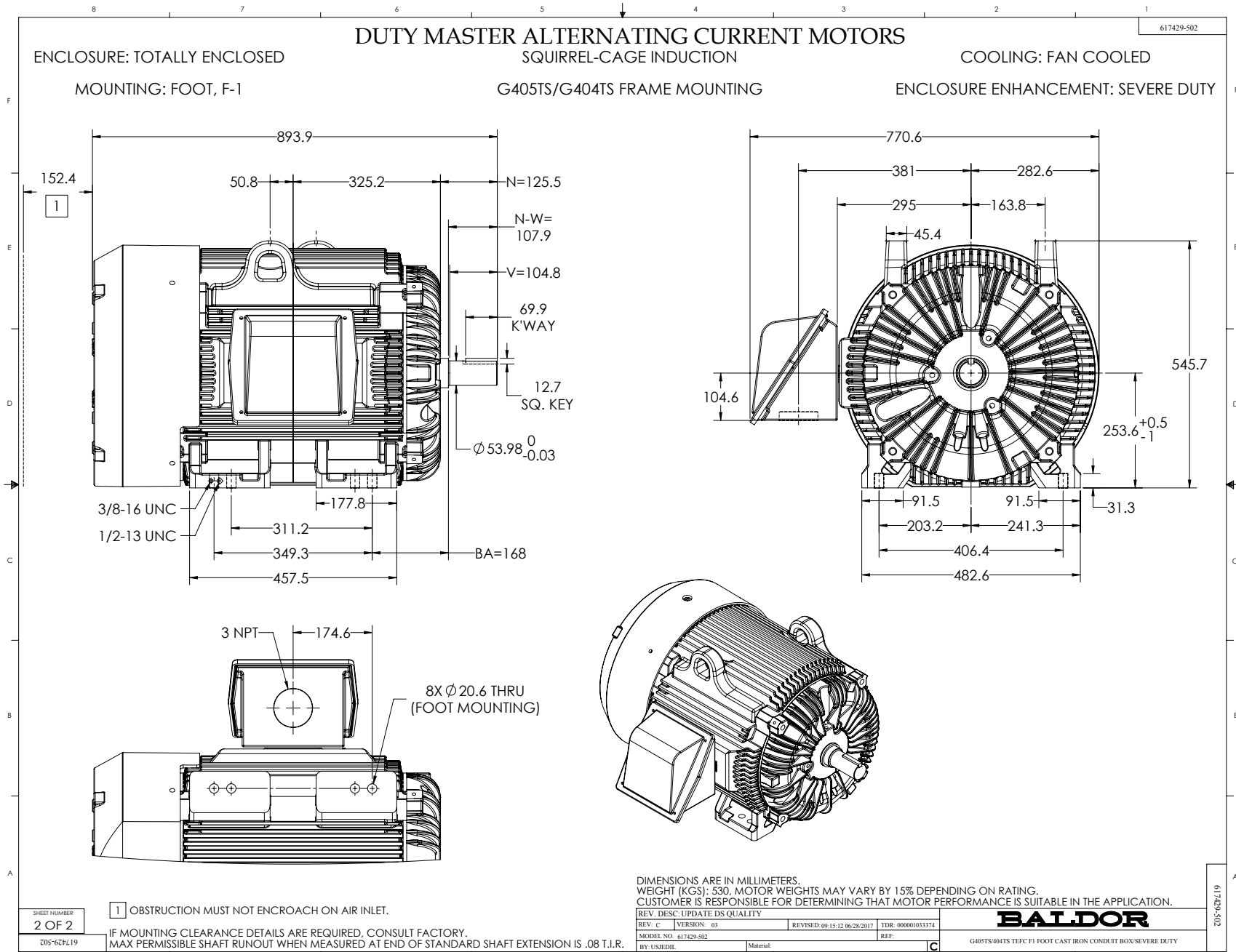

416820-036

A-C MOTOR
 CONNECTION DIAGRAM
 STANDARD 3 LEAD CONNECTED

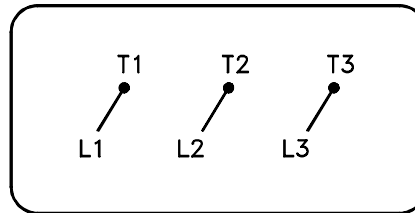

(N.P. 1575-BA)

416820-036

REV. DESC: LOADED TO BUS, C/R 335225		
REV. LTR: -	VERSION: 00	TDR: 000000538207
FILE: \MGA\00000\682	REVISED: 11:54:06 04/30/2010	
MTL: -	BY: RAGRA	

BALDOR

CONN DIAG - STANDARD 3 LEAD

SH 1 of 1

Marketing maintained PDF of MN408:

<http://www.baldor.com/support/Literature/Load.ashx/MN408?ManNumber=MN408>

Marketing maintained PDF of MN416:

<http://www.baldor.com/support/Literature/Load.ashx/MN416?ManNumber=MN416>