

TYPE	OUTPUT HP, kW	POLE	TIME RATING CONT.	VOLTAGE V	Hz	SYN SPEED R.P.M
AEH8N	200 149.2	2		380	50	3000

TOTALLY ENCLOSED FAN-COOLED TYPE, SQUIRREL-CAGE ROTOR

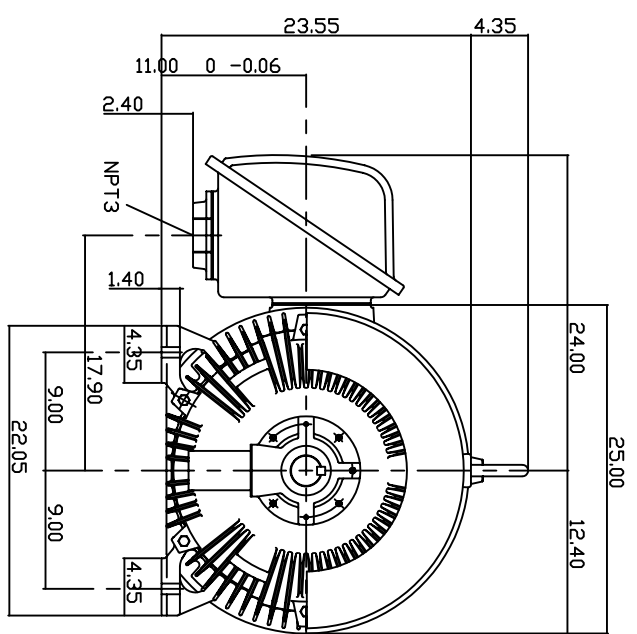
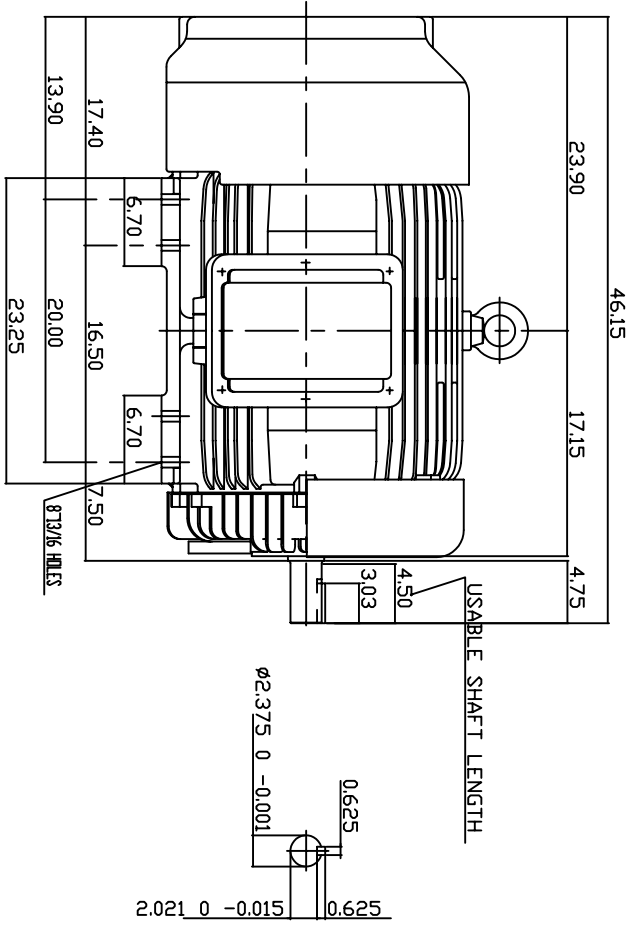

- NOTE:
1. DIMENSIONS IN INCH
  2. FRAME NO. 447TS
  3. F CLASS INSULATION, S.F.10
  4. FOR DIRECT FLEXIBLE COUPLING
  5. ENCLOSURE: IP54
  6. BEARING SIZE: DRIVE END: 6314C3  
NON-DRIVE END: 6314C3
  7. APPROX. WEIGHT: 2150 LBS

TW-56C

DWN.	T.H.Pan	FEB 17 2005
CHKD.	H.HUANG	FEB 17 2005
APPD.	C.WANG	FEB 17 2005

DATE 20050616	OUTLINE DIMENSIONS
CAT. # EP2002-50	3-PHASE INDUCTION MOTOR
DWG NO. 3A040Y685	REV. 00